

Double Post Light



30x SMD LED
(Cool White)
@ 0.2wea*



1x SMD LED
(Warm White)
@ 0.2wea*



1x 3.7V
4.4Ah NiMH*



3W Integrated
Polycrystalline*



Dust & Water
Protection*



Aluminium Alloy
Construction*



350 Lumens
at 1 metre*

*specifications per light

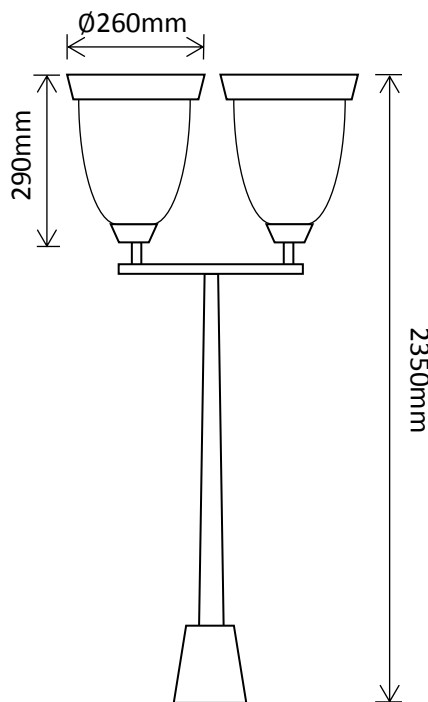

SLDPL0007B-12.4W

Features:

- Built in Photo Electric Cell
- High/Low Setting
- 6-8 hours Operation per day
- Tapered Aluminium Post
- Decorative Mounting Base
- Glass Lampshade
- Black P.C. Finish
- **1 Year Warranty!**

