

# Flood Light with Integrated Microwave Sensor and IP Camera



10W LED Panel  
(Warm White)



1x 3.7V  
8.8Ah Li-Ion



20W Separate  
Polycrystalline



Dust & Water  
Protection



ABS + PC  
Construction



1000 Lumens  
at 1 metre

## SLDFL007/CAM-BLK

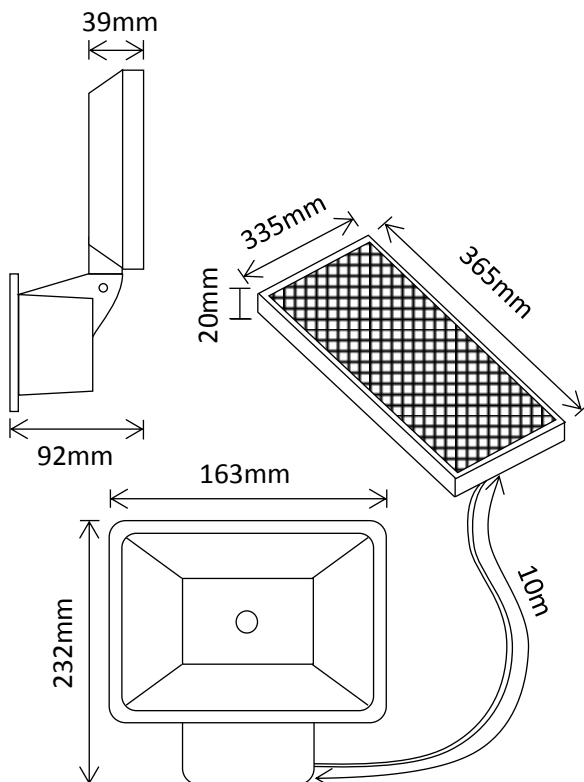
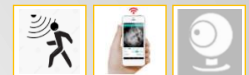

### HOUSING FEATURES

- 120 Degree Rotatable Design
- Colour: White \*

### LIGHT Features

- Day/Night Operation – integrated Photo Electric Cell
- Microwave Motion Sensor: Range – 10m
- 3 modes of Operation:
  - **Mode 1: RED** Indicator - Operate at 25% brightness until motion is detected, then run for approx. 30 secs at 100% brightness or until no further movement is detected
  - **Mode 2: GREEN** Indicator - OFF until motion is detected, then run for approx. 30 secs at 100% or until no further movement is detected
  - **Mode 3: BLUE** Indicator - Operate at 50% brightness from dusk to dawn or until battery is discharged (Sensor Bypass Mode)
- Polycrystalline Solar Panel
- 6 Hrs Charging Time

### CAMERA Features

- 3 Mega Pixels
- Day/Night Operation
- 120° viewing angle
- Concealed installation
- Internet Protocol (IP) with Wi-Fi
- Solar Powered
- 24/7 Recording Capability
- In-House Storage → 32GB TF Card
- Smart Phone Connectivity via APP

\*Background section around camera coloured black on all models for concealment purposes

2 year Warranty!

