

# 50W Flood Light – Dual Colour



5730 SMD LEDs



1x 12vDC  
30Ah Li-Ion



Dust & Water  
Protection



Die-Cast  
Aluminium Body



5000 Lumens  
at 1 metre

## SLDFL50W

### Features:

- "Plug and Play" Installation
- Built in Photo Electric Cell
- RF Remote Control Operation
- Multiple Pre-programmed Modes
- Brightness Adjustable
- Time Adjustable
- Day-Night Sensor
- Wall Mounting Bracket
- Dual Colour LEDs
- Tempered Safety Glass
- 5m Connection Cable
- Dimmable
- **1 Year Warranty!**

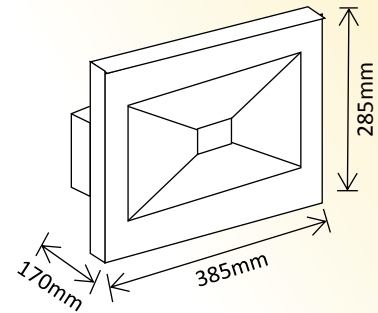

## ACCESSORIES

### SLDY-CON



"Y" connector to  
allow multiple  
commercial light  
connections to one  
Solar Panel

### SLDEXT-CABLE



10m  
Extension Cable to  
suit SLDGSK0055,  
SLDFL10W,  
SLDFL30W,  
SLDFL50W,  
SLDBTL18W &  
SLDBTL24W

\*Solar Panel Sold Separately

Flux out: 4264 lm

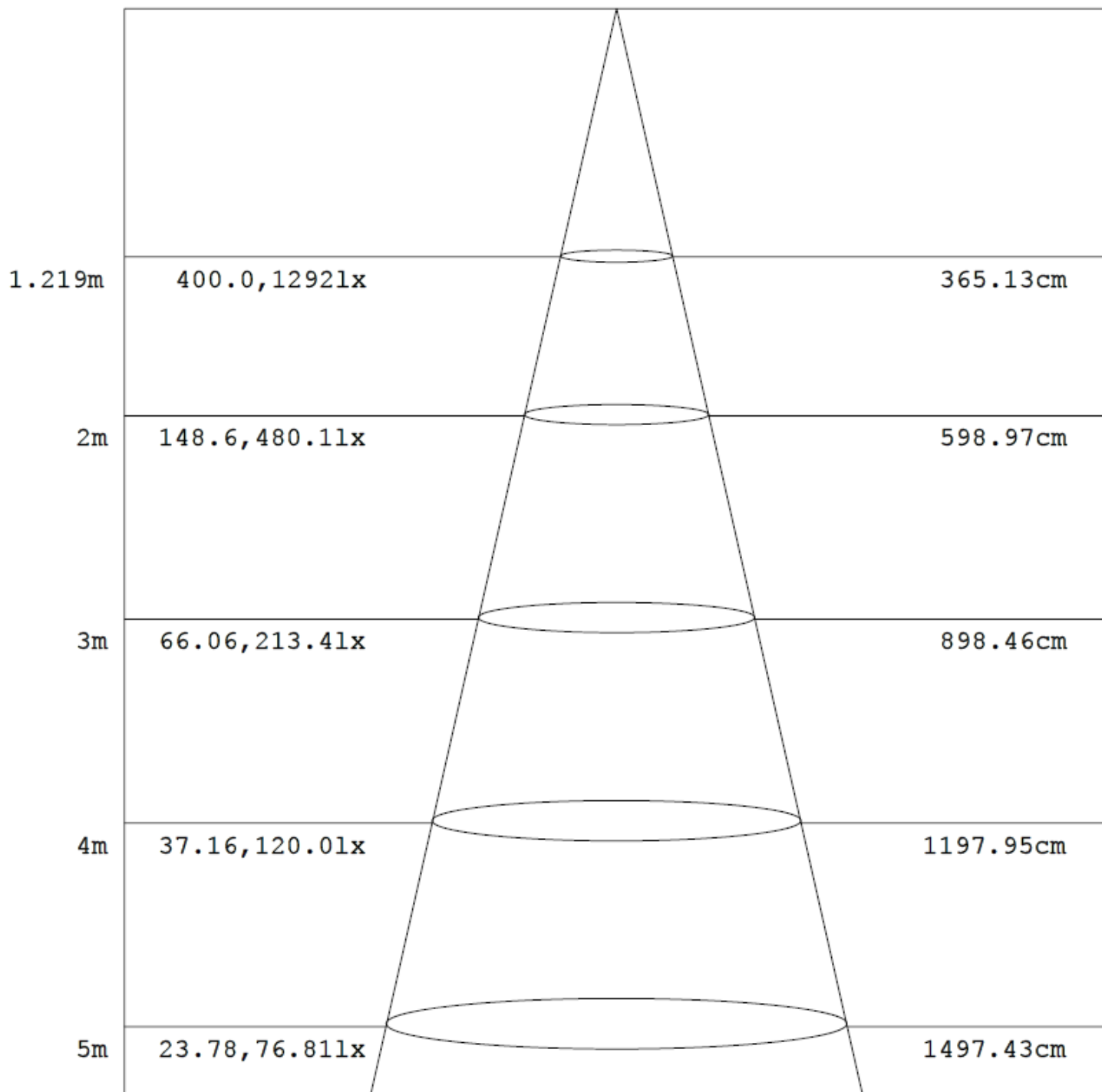

Height

Eavg, Emax

Angle: 112.53deg

Diameter

