



INSTALLATION INSTRUCTIONS FOR PART 99-6511BB

APPLICATIONS

Chrysler

Aspen 2008/Sebring 2007-08
Town and Country 2008/300/300c 2008

Dodge

Avenger 2007-08
Charger 2008/Dakota 2008/Durango 2008
Grand Caravan 2008/Journey 2009*

Magnum 2008/ Nitro 2007-08

Jeep Liberty 2008/Jeep Wrangler 2007-08*

**(Modifications to radio cavity required when installing DDIN radio.)*

99-6511BB

KIT FEATURES

- Double DIN Radio Provision
- Stacked ISO Units Provision
- DIN Mount Radio Provision with Pocket
- ISO Mount Radio Provision with Pocket



KIT COMPONENTS

- A) Double DIN Brackets/Trim Plate
- B) Radio Housing with Pocket
- C) ISO Brackets
- D) ISO Trim Plate

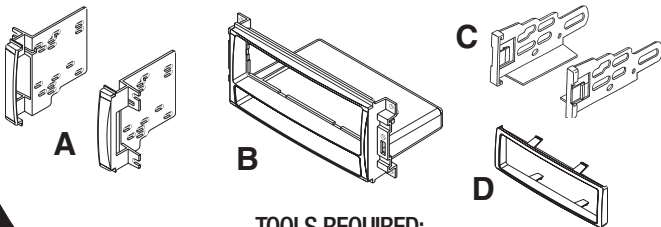

TOOLS REQUIRED:

- Small Flat Blade Screwdriver/ Panel Removal Tool
- Phillips Screwdriver
- Socket Set



1-800-221-0932



www.metraonline.com

© COPYRIGHT 2004-2008 METRA ELECTRONICS CORPORATION



TABLE OF CONTENTS

Dash Disassembly

- ***Chrysler Aspen 2008 /Dodge Durango 2008 1***
- ***Chrysler Sebring 2007-08 2***
- ***Chrysler Town and Country 2008 3,4***
- ***Chrysler 300/300C 2008 5***
- ***Dodge Avenger 2007-08 6***
- ***Dodge Dakota 2008 7***
- ***Dodge Grand Caravan 2008 3,4***
- ***Dodge Magnum/Charger 2008 5***
- ***Dodge Nitro 2007-08/Liberty 2008 8***
- ***Dodge Journey 2009 (Modifications to radio cavity required) 9***
- ***Jeep Commander 2008/Grand Cherokee 2008 10***
- ***Jeep Wrangler 2007 -08 (Modifications to radio cavity required).11***

Kit Assembly

- ***Double DIN Radio Provision 12***
- ***Stacked ISO Units Provision 13***
- ***DIN Mount Radio Provision with Pocket 14***
- ***ISO Mount Radio Povision with Pocket 15***

- **Final Assembly 16**

***Note:**

Refer also to the instructions included with the aftermarket radio.

CHRYSLER ASPEN 2008
DODGE DURANGO 2008

- 1** Disconnect the negative battery terminal to prevent an accidental short circuit.
- 2** Unsnap and remove storage cup holder assembly. (Figure A)
- 3** Remove (2) screws from bottom edge of center dash trim panel. Unsnap and remove the panel. (Figure B)
- 3** Remove (4) screws securing the radio. Unplug and remove radio. (Figure C)

Continue to kit assembly.

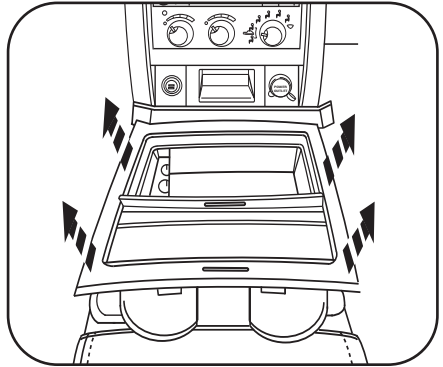
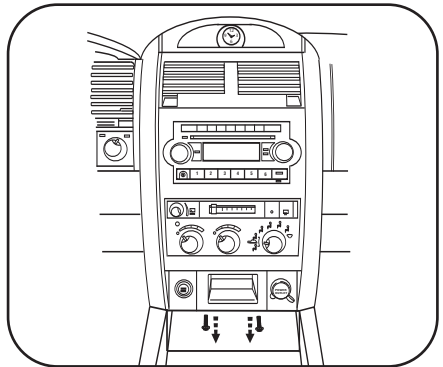
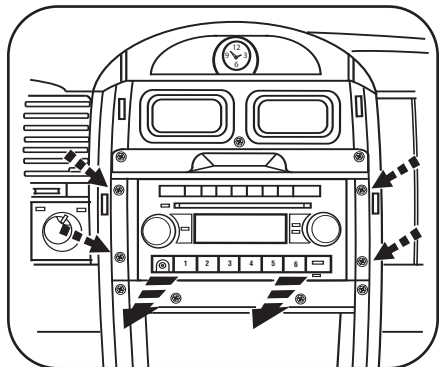
A

B

C

CHRYSLER SEBRING 2007-08

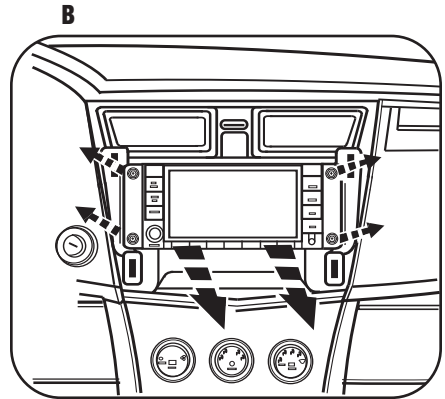
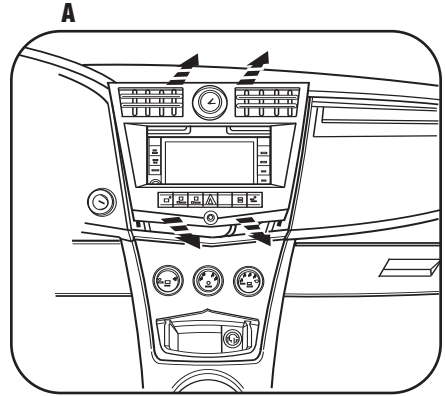
- 1** Disconnect the negative battery terminal to prevent an accidental short circuit.
- 2** Unclip entire panel surrounding radio including a/c vents and clock. Unplug and remove panel. (Figure A)
- 3** Remove (4) 7MM screws securing radio. Unplug and remove radio. (Figure B)

Continue to kit assembly.



CHRYSLER TOWN AND COUNTRY 2008 DODGE GRAND CARAVAN 2008

- 1** Disconnect the negative battery terminal to prevent an accidental short circuit.
- 2** Remove (2) screw covers facing up above radio then remove the (2) Phillips screws exposed. (Figure A)
- 3** Lift up on panel above radio then remove (2) Phillips screws exposed at front edge of radio trim panel. (Figure B)
- 4** Remove (3) plastic push pins per side of bottom trim panel then slide panel toward rear of van to access (2) screws on bottom of radio trim panel. (Figure C)

Continued on page 3.

A

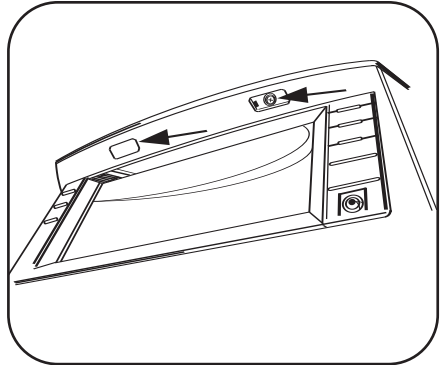

B

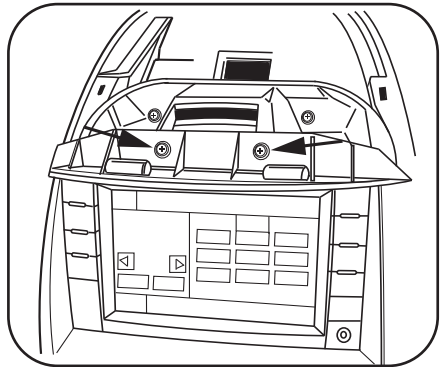

C

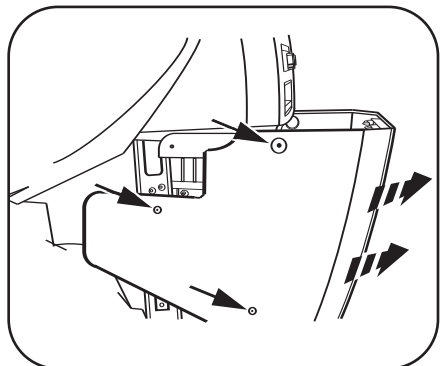

CHRYSLER TOWN AND COUNTRY 2008

DODGE GRAND CARAVAN 2008

- 5** Remove (2) Phillips screws exposed at bottom edge radio trim panel. (Figure D)
- 6** Unclip and remove entire panel surrounding radio including climate controls, vents and clock. (Figure E)
- 7** Remove (4) Phillips screws securing radio. (Figure F)

Continue to kit assembly.

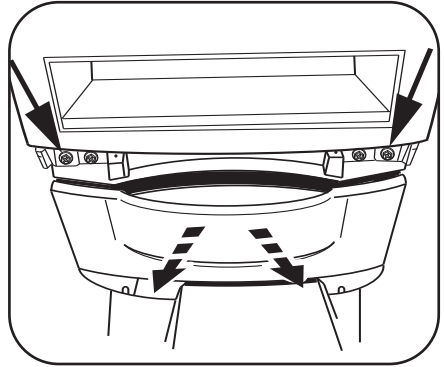
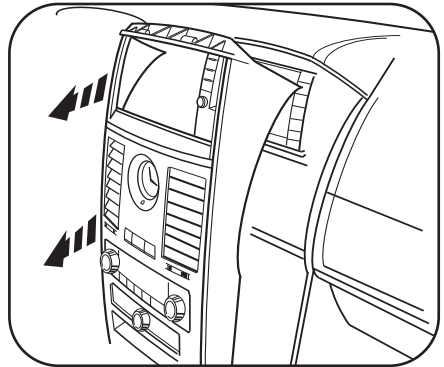
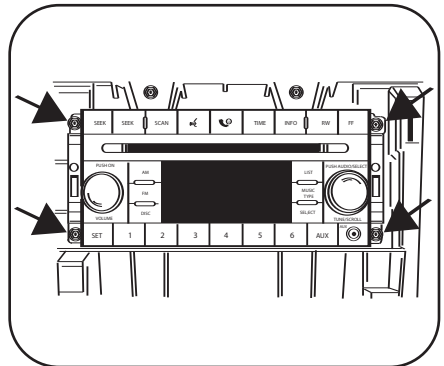
D

E

F

CHRYSLER 300/300C 2008 **DODGE MAGNUM/CHARGER 2008**

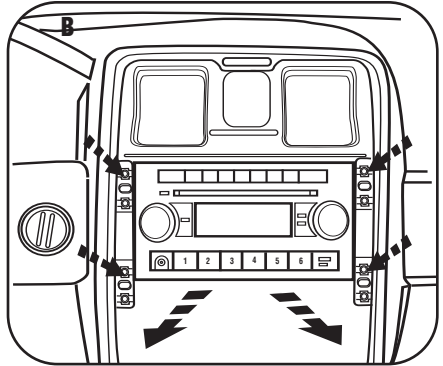
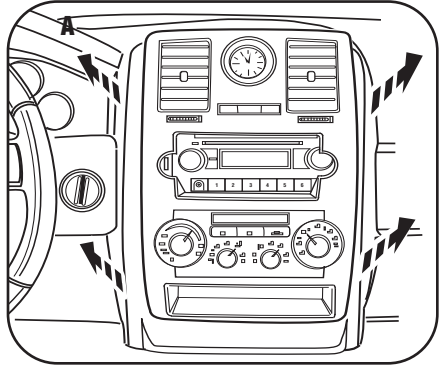
- 1** Disconnect the negative battery terminal to prevent an accidental short circuit.
- 2** Unsnap and remove center dash trim panel. (Figure A)
- 3** Remove (4) screws securing the radio. Disconnect and remove the radio. (Figure C)

Continue to kit assembly.



DODGE AVENGER 2007-2008

- 1** Disconnect the negative battery terminal to prevent an accidental short circuit.
- 2** Unclip and remove the center console trim panel. (Figure A)
- 3** Unclip the center dash trim panel. (Figure B)
- 4** Remove (4) screws securing the radio. Disconnect and remove the radio. (Figure C)
- 5** Remove (3) screws securing the radio rear support bracket and remove the bracket. (Figure D)

Continue to kit assembly.

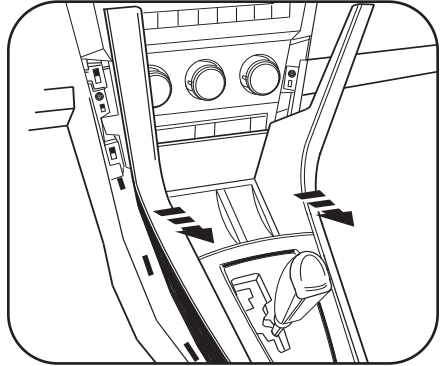
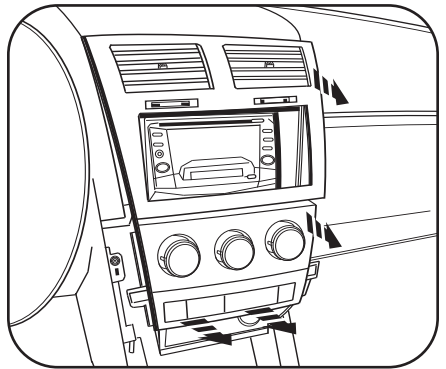
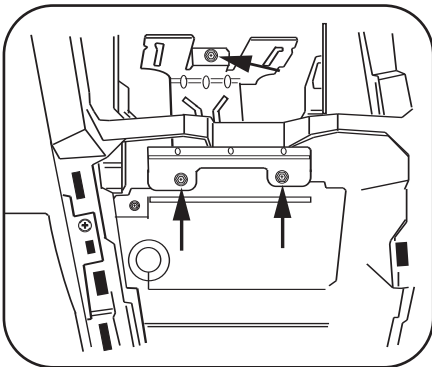
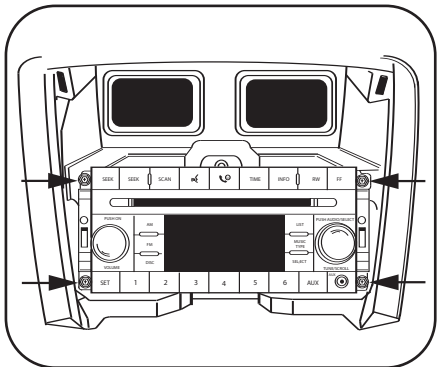
A

B

D

C

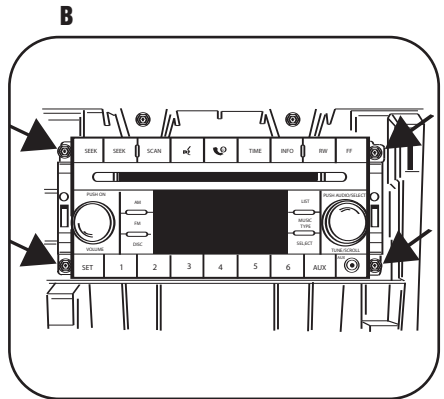
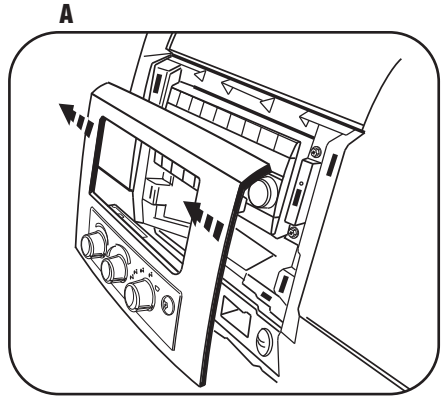
DODGE DAKOTA 2008

- 1** Disconnect the negative battery terminal to prevent an accidental short circuit.
- 2** Unclip and remove the trim panel surrounding the radio. (Figure A)
- 3** Remove (4) Phillips screws securing the radio. (Figure B)

Continue to kit assembly.



DODGE NITRO 2007-2008
JEEP LIBERTY 2008

- 1** Disconnect the negative battery terminal to prevent an accidental short circuit.
- 2** Unclip entire panel surrounding radio and climate controls, including a/c vents. Unplug and remove panel.
- 3** Remove (4) 7MM screws securing radio. Unplug and remove radio. (Figure B)

Continue to kit assembly.

A

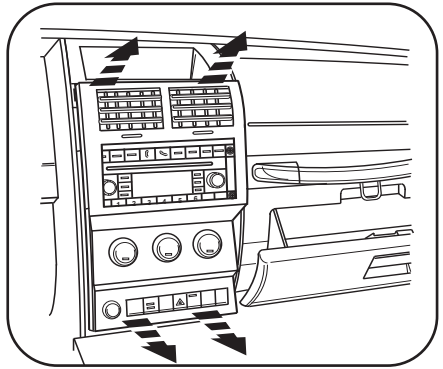

B

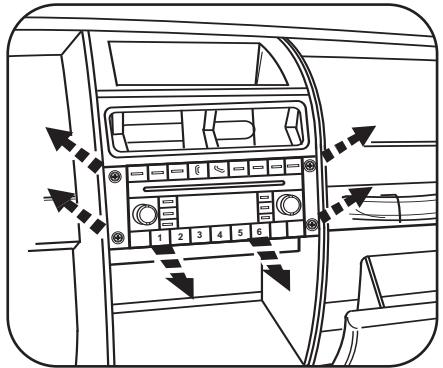

DODGE JOURNEY 2009

1 Disconnect the negative battery terminal to prevent an accidental short circuit.

2 Unclip and remove the entire factory radio trim panel including the a/c controls. (Figure A)

TIP: *Open the compartment door at the top of the radio trim panel.*

3 Remove (4) 7MM screws securing radio to dash to remove. (Figure B)

NOTE: *The top of the metal bracket in the sub dash will need to be cut to allow for the clearance of the Double DIN radio's chassis. (Figure C)*

Continue to kit assembly.

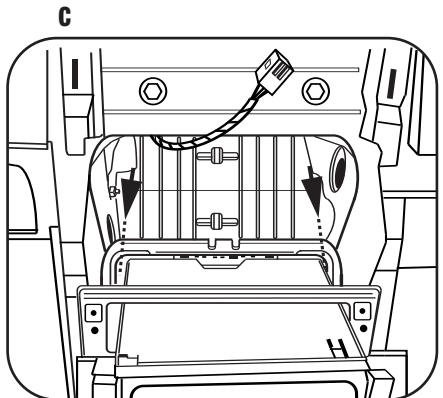
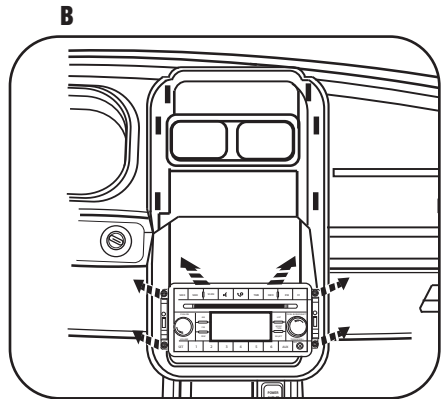
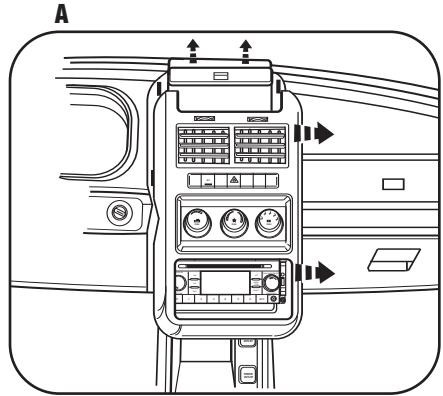

JEEP COMMANDER/GRAND CHEROKEE 2008

- 1 Disconnect the negative battery terminal to prevent an accidental short circuit.
- 2 Unsnap and remove the small trim around the console shifter. (Figure A)
- 3 Unsnap and remove the larger trim around the console shifter. (Figure B)
- 4 Remove one Phillips screw from inside the small storage pocket in the lower dash, between the power outlets. (Figure C)
- 5 Unsnap and remove the dash panel from around the radio (including climate controls). (Figure D)
- 6 Remove (4) Phillips screws securing the radio. Unplug and remove radio.

Continue to kit assembly.

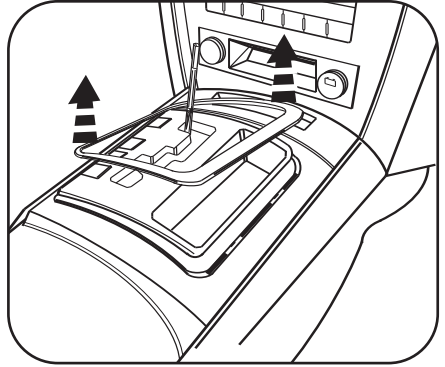
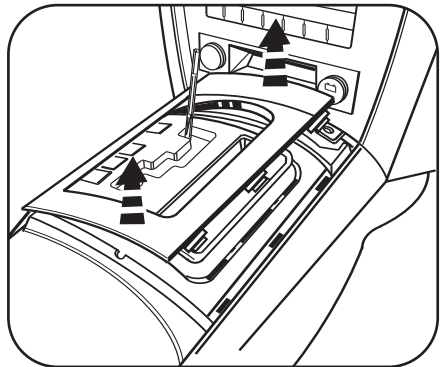
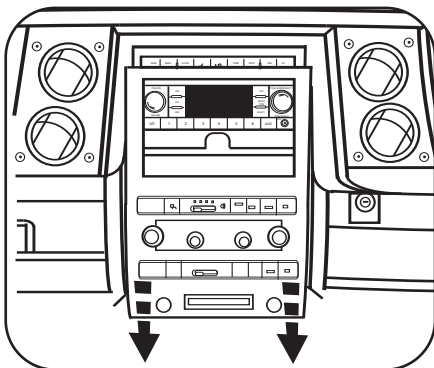
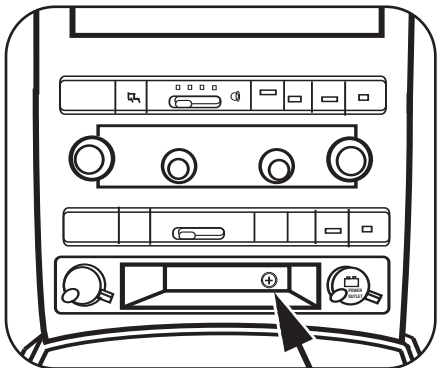
A**B****D****C**

JEEP WRANGLER 2007-2008

(Modifications to radio cavity required when installing DDIN radio.)

- 1** Disconnect the negative battery terminal to prevent an accidental short circuit.
- 2** Unclip and remove the lower center trim below a/c controls. (Figure A)
- 3** Remove (2) Phillips screws exposed behind lower center panel. (Figure A)
- 4** Unclip and remove the upper center trim starting towards the rear of the panel. (Figure A)
- 5** Remove (2) Phillips screws exposed behind upper center panel. (Figure A)
- 6** Unclip and remove entire panel surrounding radio and climate controls, including a/c vents.
- 7** Remove (4) 7MM screws securing radio. Unplug and remove radio. (Figure B)

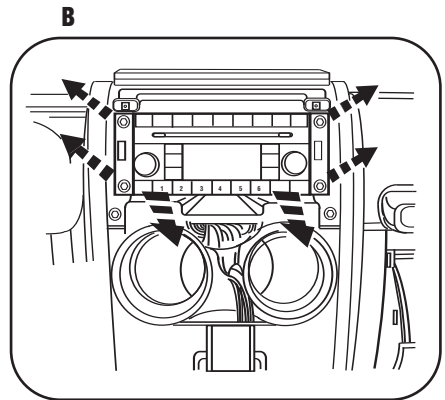
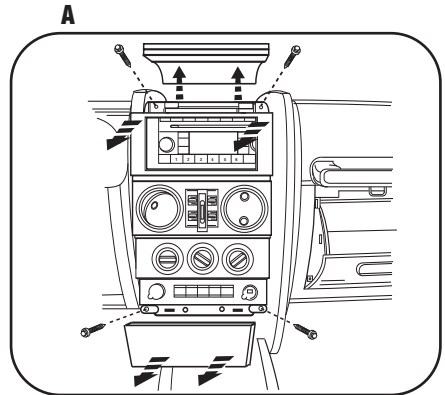

Continue to kit assembly.

DOUBLE DIN RADIO PROVISION

**Note: Refer also to the instructions included with the aftermarket radio.*

- 1 Attach the Double DIN brackets/trim plates to the Double DIN Radio using the screws supplied with the Radio. (Figure A)

Continue to final assembly.

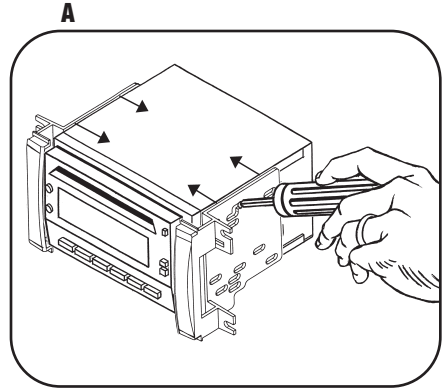

STACKED ISO UNITS PROVISION

**Note: Refer also to the instructions included with the aftermarket radio.*

- 1 Attach the Double DIN brackets/trim plates to the stacked ISO units using the screws supplied with the units. (Figure A)

Continue to final assembly.

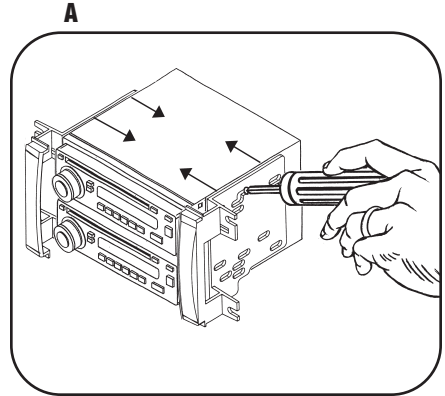

DIN MOUNT RADIO PROVISION WITH POCKET

**Note: Refer also to the instructions included with the aftermarket radio.*

- 1 Slide the DIN cage into the Radio Housing and secure by bending the metal locking tabs outward. (Figure A)
- 2 Slide the aftermarket radio into the DIN cage until it snaps into place. (Figure A)

Continue to final assembly.

A

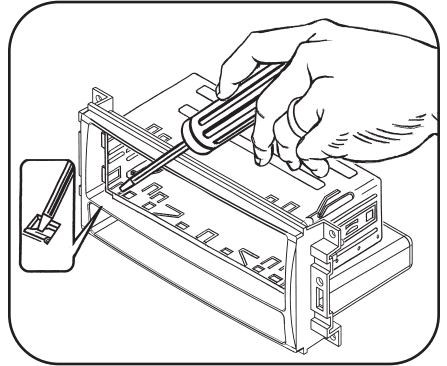

B

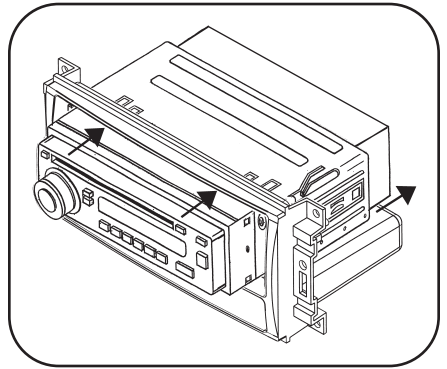

ISO MOUNT RADIO PROVISION WITH POCKET

**Note: Refer also to the instructions included with the aftermarket radio.*

- 1** Mount the ISO Brackets to the radio using the screws supplied with the radio. (Figure A)
- 2** Slide the radio into the radio opening until it snaps into place. (Figure A)
- 3** Snap the ISO Trim Plate onto the front of the Radio Housing. (Figure A)

Continue to final assembly.

A

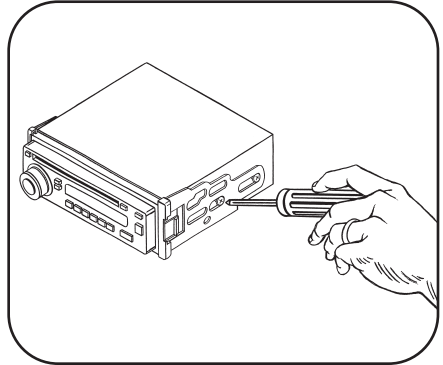

B

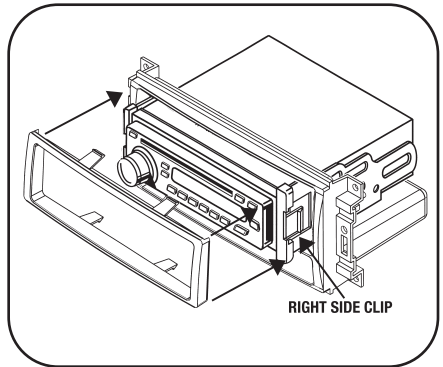



FINAL ASSEMBLY

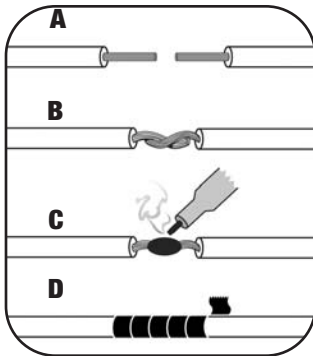

- (A) Strip wire ends back 1/2"**
- (B) Twist ends together**
- (C) Solder**
- (D) Tape**

- 1** Locate the factory wiring harness in the dash. Metra recommends using the proper mating adapter and making connections as shown. (Isolate and individually tape off the ends of any unused wires to prevent electrical short circuit.)
- 2** Re-connect the negative battery terminal and test the unit for proper operation.
- 3** Reassemble radio and dash assemblies in reverse order of disassembly.

FINAL WIRING CONNECTIONS

Make wiring connections using the EIA color code chart shown below and the instructions included with the head unit. Metra recommends making connections as shown below; Strip, Splice, Solder, Tape. Isolate and individually tape off ends of any unused wires to prevent electrical short circuit.

METRA / EIA WIRING CODE

12V Ignition / Acc. Red	Right Front (+) Gray
12V Batt / Memory. Yellow	Right Front (-). Gray/ Black
Ground. Black*	Left Front (+) White
Power Antenna. Blue	Left Front (-). White / Black
Amp Turn-On Blue / White	Right Rear (+) Violet
Amp Ground. Black / White	Right Rear (-). Violet / Black
Illumination Orange	Left Rear (+) Green
Dimmer Orange / White	Left Rear (-). Green / Black

***NOTE:** When a Black wire is not present, ground radio to vehicle chassis.
All colors may not be present on all leads due to manufacturer's specifications.

99-6511BB INSTRUCTIONS



1-800-221-0932



www.metraonline.com

REV. 04/08/08 © COPYRIGHT 2004-2008 METRA ELECTRONICS CORPORATION INST99-6511BB