



Installation instructions for part 95-5812 or 99-5812

## Ford/Lincoln/Mercury 2004-up 95-5812 or 99-5812

### KIT FEATURES

95-5812:

- ISO DDIN radio provision

99-5812:

- DIN radio provision with pocket
- ISO DIN radio provision with pocket



### KIT COMPONENTS

95-5812: • A1) Radio housing A • B1) ISO DDIN brackets • C1) Spacers • D1) (4) Screws

99-5812: • A2) Radio housing B • B2) ISO brackets • C2) Trim plate • D2) Side brackets  
• E2) Spacers • F2) (4) Screws

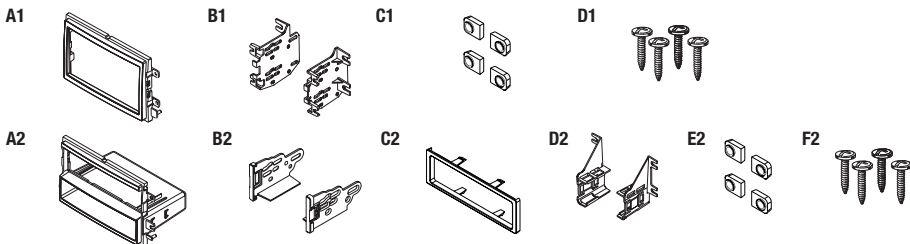

### APPLICATIONS

See application list inside cover

### WIRING & ANTENNA CONNECTIONS (sold separately)

Wiring Harness:

- Please visit [metraonline.com](http://metraonline.com) for wiring harness options

Antenna Adapter:

- 40-CR10

### TOOLS REQUIRED

- Cutting tool • Panel removal tool
- Phillips screwdriver • Socket set

**CAUTION!** All accessories, switches, climate controls panels, and especially air bag indicator lights must be connected before cycling the ignition. Also, do not remove the factory radio with the key in the on position, or while the vehicle is running.

REV. 3/20/2018 INST-5812



## Installation instructions for part 95-5812 or 99-5812

### Applications

<b>Ford</b>	<b>Lincoln</b>
Econoline (E-Series).....2009-up	Mark LT .....2006-2008
Edge.....2007-2010	MKX (with NAV) .....2007-2010
Expedition .....2007-2014	Navigator (with NAV).....2007-2014
Expedition (fleet)..... 2015	
Explorer .....2006-2010	<b>Mercury</b>
Explorer Sport Trac .....2006-2010	Milan .....2006-2009
F-150 .....2004-2008	Mountaineer .....2006-2010
F-250/350/450/550 .....2005-2012	Monterey .....2004-2007
F-250/350/450/550 (without 8" screen).....2013-2016	Montego .....2005-2007
F-650/750.....2011-up	Sable .....2008-2009
Five Hundred .....2005-2007	
Focus .....2005-2007	
Freestar .....2004-2007	
Freestyle .....2005-2007	
Fusion .....2006-2009	
Mustang .....2005-2009	
Taurus .....2008-2009	
Taurus X .....2008-2009	
Transit Connect (late generation)..... 2012	
Transit Connect .....2013	

### Table of Contents

<b>Dash Disassembly</b>	<b>Lincoln</b>
<b>Ford</b>	
- Econoline (E-Series) 2009-up .....7	- Mark LT 2006-2008.....3
- Edge 2007-2010 .....3	- MKX (with NAV) 2007-2010 .....8
- Expedition 2007-2014 .....3	<b>Mercury</b>
- Expedition (fleet) 2015.....3	- Navigator (with NAV) 2007-2014 .....8
- Explorer 2006-2010 .....6	- Milan 2006-2009.....4
- Explorer Sport Trac 2006-2010.....6	- Mountaineer 2006-2010.....6
- F-150 2004-2008.....3	- Monterey 2004-2007.....5
- F-250/350/450/550 2005-2012 .....7	- Montego 2005-2007.....4
- F-250/350/450/550 (without 8" screen) 2013-2016 7	- Sable 2008-2009 .....4
- F-650/750 2011-up.....7	
- Five Hundred 2005-2007 .....4	<b>Kit Assembly</b>
- Focus 2005-2007 .....6	- DIN radio provision with pocket .....9
- Freestar 2004-2007 .....5	- ISO DIN radio provision with pocket .....10
- Freestyle 2005-2007 .....5	- ISO DDIN radio provision.....11
- Fusion 2006-2009.....4	
- Mustang 2005-2009.....3	
- Taurus 2008-2009 .....4	
- Taurus X 2008-2009 .....5	
- Transit Connect (late generation) 2012.....7	
- Transit Connect 2013.....7	

## Dash Disassembly

Ford F-150 2004-2008

Ford Edge 2007-2010

Ford Expedition 2007-2014

Ford Expedition (fleet) 2015

Lincoln Mark LT 2006-2008

1. Unsnap and remove entire panel surrounding the radio and climate controls. (Figure A)
2. Remove (4) 9/32" screws to remove the factory radio. (Figure B)

*Continue to kit assembly*

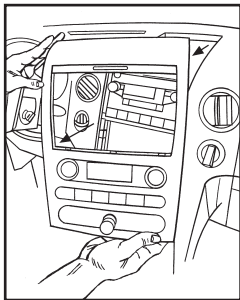

(Figure A)

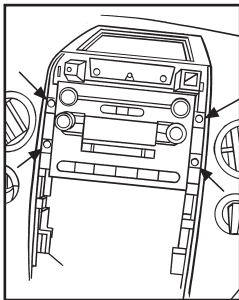

(Figure B)

Ford Mustang 2005-2009

1. Remove the small rectangular shifter lever trim panel if equipped. (Figure A)
2. Remove (2) Phillips screws from under the center armrest at the back of the shifter trim panel (including cup holders). (Figure B)
3. Unclip and remove panel. (Figure B)
4. Unclip and remove the (2) center stack trim panels from the left and right side of the radio and climate controls. (Figure C)
5. Remove (6) 9/32" screws from center trim panel surrounding the radio and climate controls then unclip and remove panel. (Figure D)
6. Remove (4) 9/32" screws from the radio to remove. (Figure E)

*Continue to kit assembly*

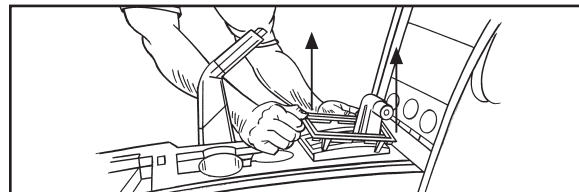

(Figure A)

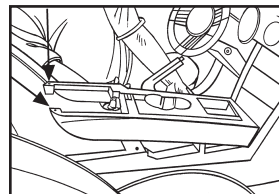

(Figure B)

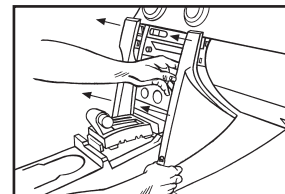

(Figure C)

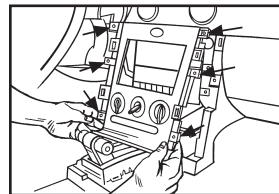

(Figure D)

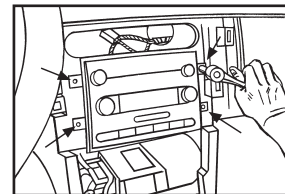

(Figure E)



## Installation instructions for part 95-5812 or 99-5812

### Dash Disassembly

**Ford Five Hundred 2005-2007**  
**Ford Taurus 2008-2009**  
**Mercury Montego 2005-2007**  
**Mercury Sable 2008-2009**

1. Unclip and remove the small rectangular trim around shift lever. (Figure A)
2. Unclip and remove the entire panel (including cup holders) surrounding the shift lever. (Figure B)
3. Remove (2) 9/32" screws at the bottom of the center radio/climate control panel. (Figure C)
4. Unclip and remove the center panel. (Figure D)
5. Remove (4) 9/32" screws from the radio to remove. (Figure E)

*Continue to kit assembly*

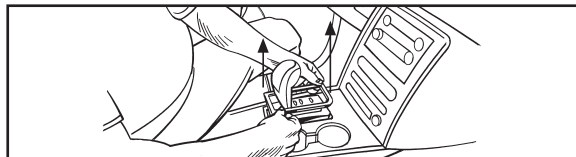

(Figure A)

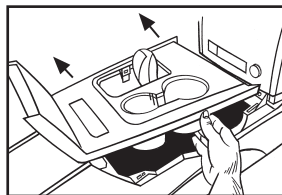

(Figure B)

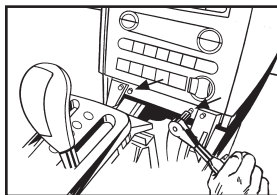

(Figure C)

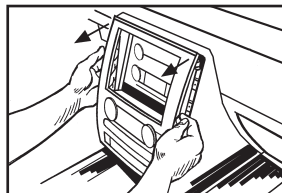

(Figure D)

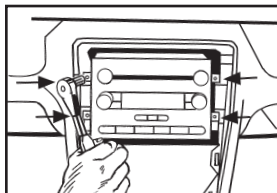

(Figure E)

**Ford Fusion 2006-2009**  
**Mercury Milan 2006-2009**

1. Unsnap and remove entire panel surrounding the radio and climate controls. (Figure A)
2. Remove (4) 9/32" screws to remove the factory radio. (Figure B)

*Continue to kit assembly*

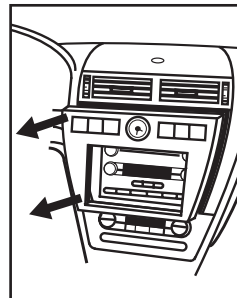

(Figure A)

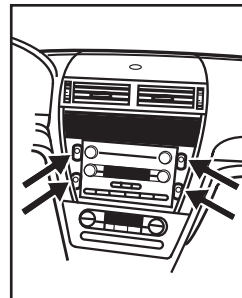

(Figure B)



## Installation instructions for part 95-5812 or 99-5812

### Dash Disassembly

**Ford Freestyle 2005-2007  
Ford Taurus X 2008-2009**

1. Unclip and remove entire panel surrounding the radio and A/C controls. (Figure A)
2. Remove (4) 9/32" screws from radio to remove. (Figure B)

*Continue to kit assembly*

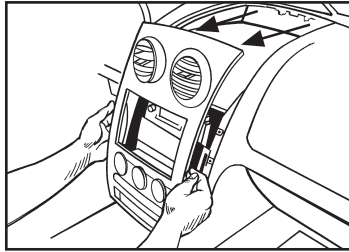

(Figure A)

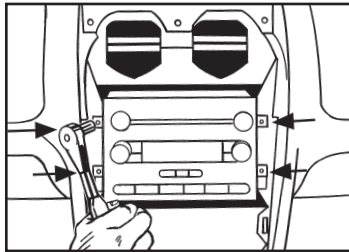

(Figure B)

**Ford Freestar 2004-2007  
Mercury Monterey 2004-2007**

1. Unsnap and remove entire panel surrounding the radio and climate controls. (Figure A)
2. Remove (4) 9/32" screws to remove the factory radio. (Figure B)

*Continue to kit assembly*

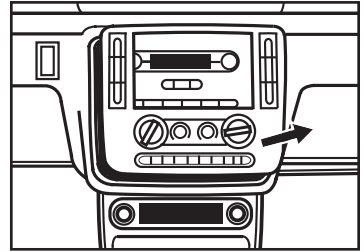

(Figure A)

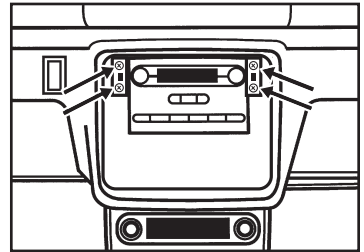

(Figure B)



## Installation instructions for part 95-5812 or 99-5812

### Dash Disassembly

#### Ford Focus 2005-2007

1. Unsnap and remove entire panel surrounding the radio and climate controls. (Figure A)
2. Remove (4) 9/32" screws to remove the factory radio. (Figure B)

*Continue to kit assembly*

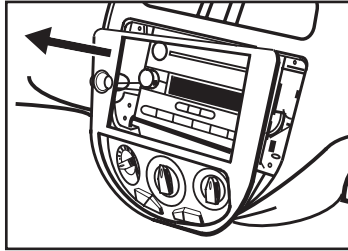

(Figure A)

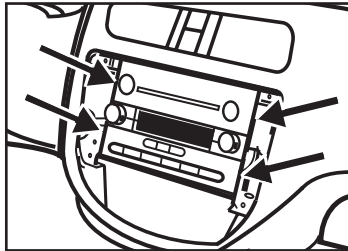

(Figure B)

#### Ford Explorer/Explorer Sport Trac 2006-2010

#### Mercury Mountaineer 2006-2010

1. Open center console and remove (2) Phillips screws then unclip and remove entire panel surrounding shifter. (Figure A)
2. Remove dash panel surrounding radio to access the factory radio screws. (Figure B)
3. Remove (4) 9/32" screws to remove the factory radio. (Figure C)

*Continue to kit assembly*

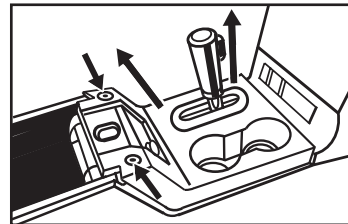

(Figure A)

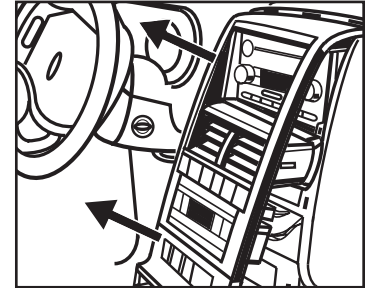

(Figure B)

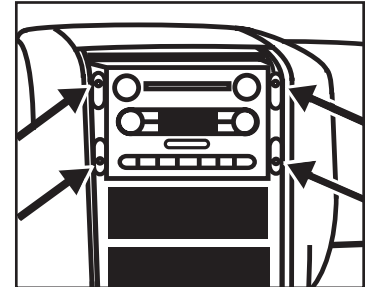

(Figure C)



## Installation instructions for part 95-5812 or 99-5812

### Dash Disassembly

#### Ford Econoline (E-Series) 2009-up F-250/350/450/550 2005-2007

1. Unsnap and remove entire panel surrounding the radio and climate controls. (Figure A)
2. Remove (4) 9/32" screws to remove the factory radio. (Figure B)

*Continue to kit assembly*

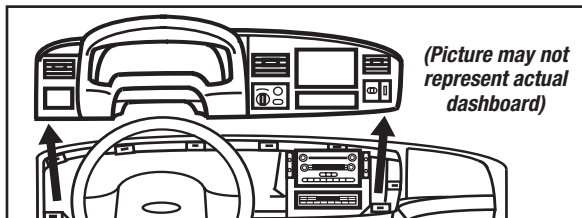

(Figure A)



(Figure B)

#### Ford F-250/350/450/550 2008-2012 F-250/350/450/550 (without 8" screen) 2013-2016 F-650/750 2011-up

1. Unclip and remove the power outlet panel and the blank panel on the left and right side of the radio trim panel. (Figure A)
2. Remove the (2) 9/32" screws exposed behind the two panels previously removed.
3. Unclip and remove the entire radio trim panel including the A/C control and vents.
4. Remove (4) 9/32" screws securing the radio.

*Continue to kit assembly*

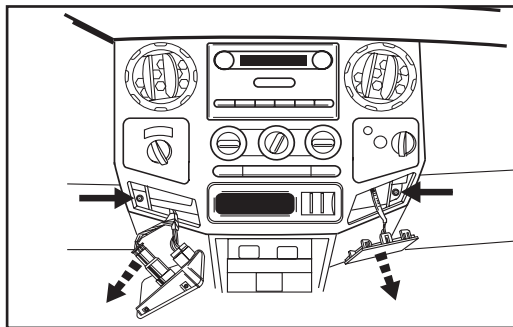

(Figure A)

#### Ford Transit Connect 2013 Transit Connect (late generation) 2012

1. Remove the radio trim panel. (Figure A)
2. Remove (4) screws securing the radio and then remove.

*Continue to kit assembly*

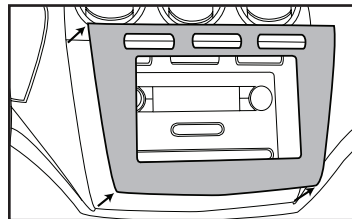

(Figure A)

## Dash Disassembly

### Lincoln MKX (with NAV) 2007-2010

1. Open center console lid and unclip and remove the center console trim panel surrounding the shifter. (Figure A)
2. Remove (2) Phillips screws from the storage bin then unclip and remove the bin. (Figure B)
3. Unclip and remove the upper and lower center trim panel as one assembly. (Figure C)
4. Remove (4) 9/32" screws securing the radio. Unplug and remove the radio.

Continue to kit assembly

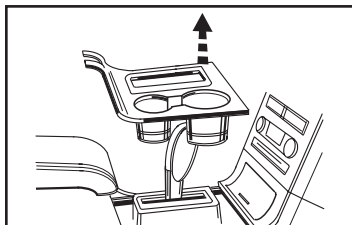

(Figure A)

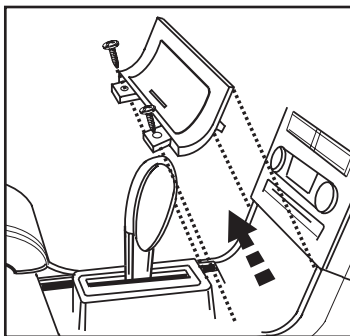

(Figure B)

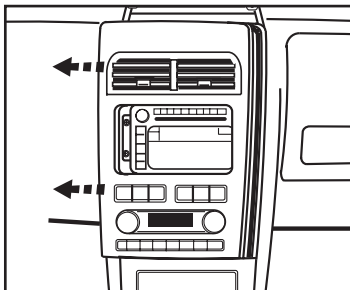

(Figure C)

### Lincoln Navigator (with NAV) 2007-2014

1. Unclip and remove the panel surrounding the shifter. (Figure A)
2. Remove (2) 9/32" screws from the bottom of the radio/climate control trim panel. (Figure B)
3. Unclip and remove the entire panel surrounding the radio and including the climate controls. (Figure B)
4. Remove (4) 9/32" screws securing the radio. Unplug and remove the radio.

Continue to kit assembly

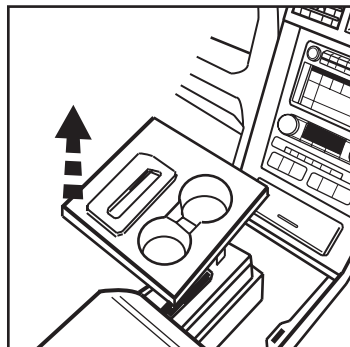

(Figure A)

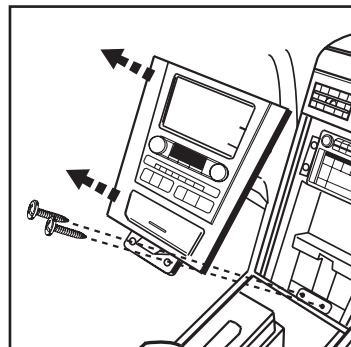

(Figure B)



## Kit Assembly

### DIN radio provision with pocket

- (a) For the **Ford Econoline 2009-up, Edge 2007-2010, Expedition 2007-2014, Expedition (fleet) 2015, Explorer & Explorer Sport Trac 2006-2010, F-650/750 2011-up, F-250/350/450/550 2008-2016, F-150 2004-2008, Fusion 2006-2009, Transit Connect 2012-2013 / Lincoln Mark LT 2006-2008, MKX (with NAV) 2007-2010, Navigator (with NAV) 2007-2014 / Mercury Milan 2006-2009, Mountaineer 2006-2010**, attach the *spacers* to the mounting tabs on *radio housing B*. Use the (4) screws provided to secure the radio housing to the vehicle. (Figure A)

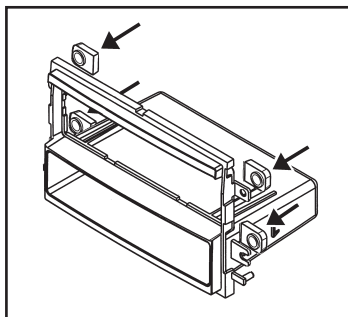

(Figure A)

- (b) For the **Ford F-250/350/450/550 2005-2007, Focus 2005-2007, Freestar 2004-2007, Monterey 2004-2007**, slide the *side brackets* onto the sides of *radio housing B*. (Figure B)

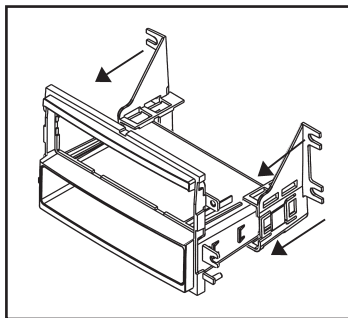

(Figure B)

- (c) If your vehicle is not listed in steps (a) or (b), proceed to Step 2.

2. Remove the metal DIN sleeve from the aftermarket radio.
3. Slide the sleeve into *radio housing B* and secure by bending the metal locking tabs outward. (Figure C)
4. Slide the radio into the sleeve until it snaps in place. (Figure D)
5. Locate the factory wiring harness and antenna connection in the dash. Metra recommends using the proper mating adapter from Metra or AXCESS. Test the radio for proper operation.
6. Reassemble the dash in reverse order of disassembly.

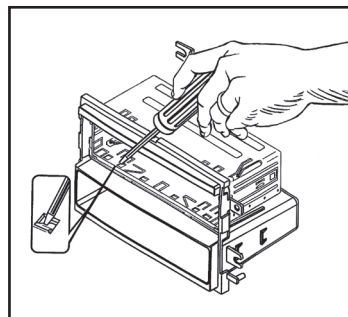

(Figure C)

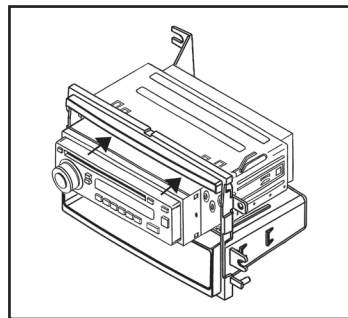

(Figure D)

## Kit Assembly

### ISO DIN radio provision with pocket

1. (a) For the **Ford Econoline 2009-up**, **Edge 2007-2010**, **Expedition 2007-2014**, **Expedition (fleet) 2015**, **Explorer & Explorer Sport Trac 2006-2010**, **F-650/750 2011-up**, **F-250/350/450/550 2008-2016**, **F-150 2004-2008**, **Fusion 2006-2009**, **Transit Connect 2012-2013 / Lincoln Mark LT 2006-2008**, **MKX (with NAV) 2007-2010**, **Navigator (with NAV) 2007-2014 / Mercury Milan 2006-2009**, **Mountaineer 2006-2010**, attach the *spacers* to the mounting tabs on *radio housing B*. Use the (4) screws provided to secure the *radio housing* to the vehicle. (Figure A)

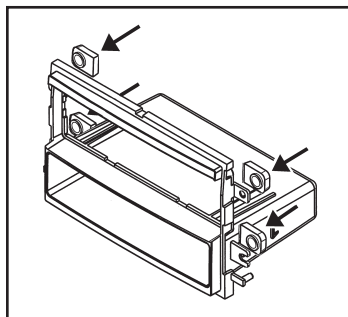

(Figure A)

- (b) For the **Ford F-250/350/450/550 2005-2007**, **Focus 2005-2007**, **Freestar 2004-2007**, **Monterey 2004-2007**, slide the *side brackets* onto the sides of *radio housing B*. (Figure B)

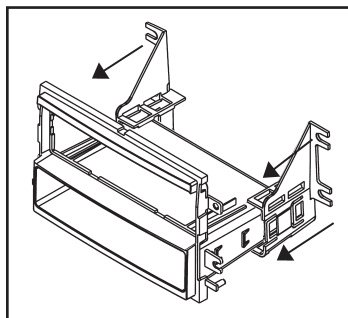

(Figure B)

- (c) If your vehicle is not listed in steps (a) or (b), proceed to step 2.

- Remove the metal DIN sleeve and trim ring from the aftermarket radio.
- Mount the *ISO brackets* to the radio with the screws supplied with the radio. (Figure C)
- Slide the radio into the radio opening until the side clips engage. (Figure D)
- Snap the *trim plate* into *radio housing B*. (Figure D)
- Locate the factory wiring harness and antenna connection in the dash. Metra recommends using the proper mating adapter from Metra or AXCESS. Test the radio for proper operation.
- Reassemble the dash in reverse order of disassembly.

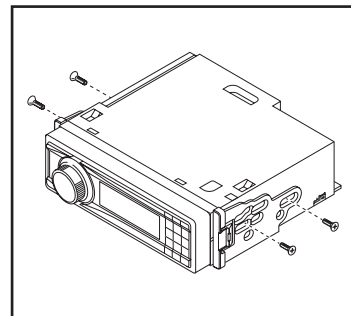

(Figure C)

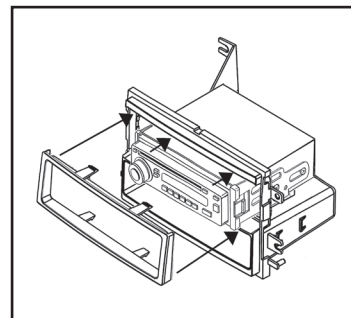

(Figure D)

## Kit Assembly

### ISO DDIN radio provision

1. Attach the *ISO DDIN brackets* to *radio housing A*. (Figure A)
2. (a) For the **Ford Econoline 2009-up, Edge 2007-2010, Expedition 2007-2014, Expedition (fleet) 2015, Explorer & Explorer Sport Trac 2006-2010, F-650/750 2011-up, F-250/350/450/550 2008-2016, F-150 2004-2008, Fusion 2006-2009, Transit Connect 2012-2013 / Lincoln Mark LT 2006-2008, MKX (with NAV) 2007-2010, Navigator (with NAV) 2007-2014 / Mercury Milan 2006-2009, Mountaineer 2006-2010**, attach the *spacers* to the front mounting tabs (Figure B). Then cut and remove the rear mounting tabs from the brackets (Figure C). Use the (4) screws provided to secure the radio housing to the vehicle.

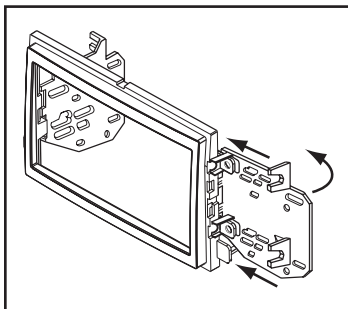

(Figure A)

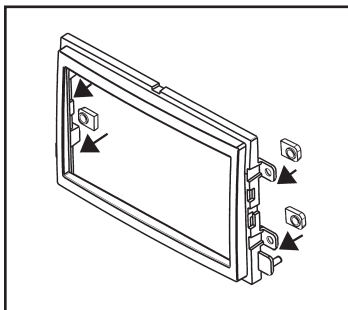

(Figure B)

- (b) For the **Ford Five Hundred 2005-2007, Freestyle 2005-2007, Mustang 2005-2009, Taurus & Taurus X 2008-2009 / Mercury Montego 2005-2007, Sable 2008-2009**, cut and remove the rear mounting tabs from the brackets. (Figure C)

(c) If your vehicle is not listed in steps (a) or (b), proceed to step 3.

3. Slide the radio into the radio housing and secure using the screws supplied with the radio. (Figure D)
4. Locate the factory wiring harness and antenna connection in the dash. Metra recommends using the proper mating adapter from Metra or AXCESS. Test the radio for proper operation.
5. Reassemble the dash in reverse order of disassembly.

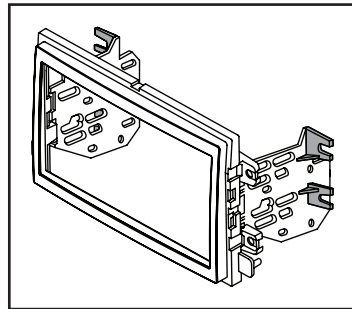

(Figure C)

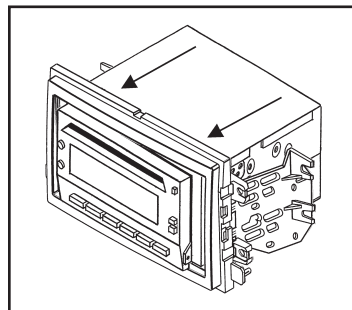

(Figure D)



Installation instructions for part 95-5812 or 99-5812



## IMPORTANT

If you are having difficulties with the installation of this product, please call our Tech Support line at **1-800-253-TECH**. Before doing so, look over the instructions a second time, and make sure the installation was performed exactly as the instructions are stated. Please have the vehicle apart and ready to perform troubleshooting steps before calling.



### **KNOWLEDGE IS POWER**

Enhance your installation and fabrication skills by enrolling in the most recognized and respected mobile electronics school in our industry. Log onto [www.installerinstitute.com](http://www.installerinstitute.com) or call 800-354-6782 for more information and take steps toward a better tomorrow.



**Metra recommends MECP certified technicians**

REV. 3/20/2018 INST-5812



Instrucciones de instalación para la pieza 95-5812 o 99-5812

## Ford/Lincoln/Mercury 2004 y mas 95-5812 o 99-5812

### CARACTERÍSTICAS DEL KIT

95-5812:

- Provisión de radio ISO DDIN

99-5812:

- Provisión de radio DIN con bolsillo
- Provisión de radio ISO DIN con bolsillo



### COMPONENTES DEL KIT

95-5812: • A1) Carcasa de radio A • B1) Soportes ISO DDIN • C1) Espaciadores • D1) (4) Tornillos

99-5812: • A2) Carcasa de radio B • B2) Soportes ISO • C2) Placa de moldura • D2) Soportes laterales  
• E2) Espaciadores • F2) (4) Tornillos

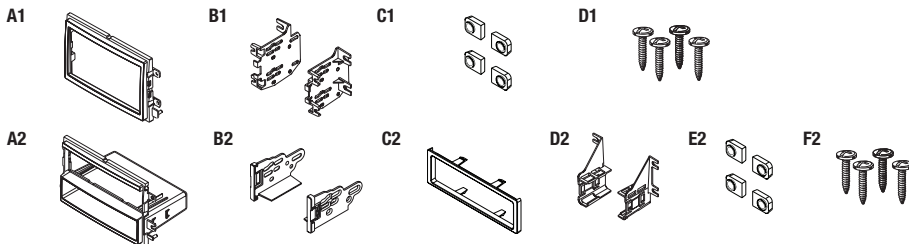

### APLICACIONES

Ver interior de la portada

### CABLEADO Y CONEXIONES DE ANTENA

(se venden por separado)

Arnés de cableado:

- Visite [metraonline.com](http://metraonline.com) para las opciones del arnés

Adaptador de antena:

- 40-CR10

### HERRAMIENTAS REQUERIDAS

- Herramienta de corte • Herramienta para quitar paneles
- Destornillador Phillips • llave de tubo

**¡PRECAUCIÓN!** Todos los accesorios, interruptores, paneles de controles de clima y especialmente las luces del indicador de las bolsas de aire deben estar conectados antes ciclar la ignición. Además, no quite el radio de fábrica con la llave en la posición o de encendido ni con el vehículo funcionando.

REV. 3/20/2018 INST-5812



## Instrucciones de instalación para la pieza 95-5812 o 99-5812

### Aplicaciones

<b>Ford</b>	<b>Lincoln</b>
Econoline (E-Series) ..... 2009 y mas	Mark LT ..... 2006-2008
Edge ..... 2007-2010	MKX (con NAV) ..... 2007-2010
Expedition ..... 2007-2014	Navigator (con NAV)..... 2007-2014
Expedition (flota)..... 2015	
Explorer ..... 2006-2010	<b>Mercury</b>
Explorer Sport Trac ..... 2006-2010	Milan ..... 2006-2009
F-150 ..... 2004-2008	Mountaineer ..... 2006-2010
F-250/350/450/550 ..... 2005-2012	Monterey ..... 2004-2007
F-250/350/450/550 (sin pantalla 8")..... 2013-2016	Montego ..... 2005-2007
F-650/750 ..... 2011 y mas	Sable ..... 2008-2009
Five Hundred ..... 2005-2007	
Focus ..... 2005-2007	
Freestar ..... 2004-2007	
Freestyle ..... 2005-2007	
Fusion ..... 2006-2009	
Mustang ..... 2005-2009	
Taurus ..... 2008-2009	
Taurus X ..... 2008-2009	
Transit Connect (generación tardía) ..... 2012	
Transit Connect ..... 2013	

### Indice

#### Desmontaje del tablero

<b>Ford</b>	<b>Lincoln</b>
- Econoline (E-Series) 2009 y mas ..... 7	- Mark LT 2006-2008 ..... 3
- Edge 2007-2010 ..... 3	- MKX (con NAV) 2007-2010 ..... 8
- Expedition 2007-2014 ..... 3	<b>Mercury</b>
- Expedition (flota) 2015 ..... 3	- Navigator (con NAV) 2007-2014 ..... 8
- Explorer 2006-2010 ..... 6	- Milan 2006-2009 ..... 4
- Explorer Sport Trac 2006-2010 ..... 6	- Mountaineer 2006-2010 ..... 6
- F-150 2004-2008 ..... 3	- Monterey 2004-2007 ..... 5
- F-250/350/450/550 2005-2012 ..... 7	- Montego 2005-2007 ..... 4
- F-250/350/450/550 (sin pantalla 8") 2013-2016 ..... 7	- Sable 2008-2009 ..... 4
- F-650/750 2011 y mas ..... 7	
- Five Hundred 2005-2007 ..... 4	<b>Ensamble del kit</b>
- Focus 2005-2007 ..... 6	- Provisión de radio DIN con bolsillo ..... 9
- Freestar 2004-2007 ..... 5	- Provisión de radio ISO DIN con bolsillo ..... 10
- Freestyle 2005-2007 ..... 5	- Provisión de radio ISO DDIN ..... 11
- Fusion 2006-2009 ..... 4	
- Mustang 2005-2009 ..... 3	
- Taurus 2008-2009 ..... 4	
- Taurus X 2008-2009 ..... 5	
- Transit Connect (generación tardía) 2012 ..... 7	
- Transit Connect 2013 ..... 7	

## Desmontaje del tablero

Ford F-150 2004-2008  
Ford Edge 2007-2010  
Ford Expedition 2007-2014  
Ford Expedition (flota) 2015  
Lincoln Mark LT 2006-2008

1. Suelte a presión y quite todo el panel que rodea el radio y los controles del clima. (Figura A)
2. Quite los (4) tornillos de 9/32" para quitar el radio de fábrica. (Figura B)

*Continúe con el ensamble del kit*

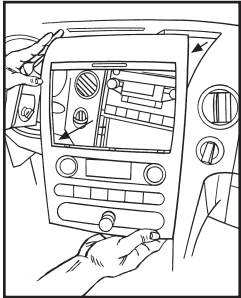

(Figura A)

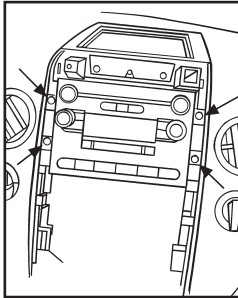

(Figura B)

Ford Mustang 2005-2009

1. Quite el pequeño panel de la moldura de la palanca de velocidades si se incluye. (Figura A)
2. Quite los (2) tornillos Phillips de debajo del descansabrazos central en la parte posterior del panel de la moldura de la palanca de velocidades (incluyendo los portavasos). (Figura B)
3. Desenganche y quite el panel. (Figura B)
4. Desenganche y quite los (2) paneles de moldura de la pila central del lado izquierdo y derecho del radio de fábrica y los controles del clima. (Figura C)
5. Quite los (6) tornillos de 9/32" del panel de moldura central que rodea el radio y los controles del clima y luego desenganche y quite el panel. (Figura D)
6. Quite los (4) tornillos de 9/32" del radio para quitarlo. (Figura E)

*Continúe con el ensamble del kit*

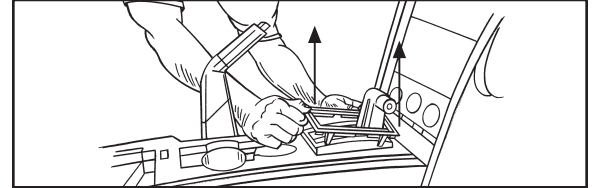

(Figura A)

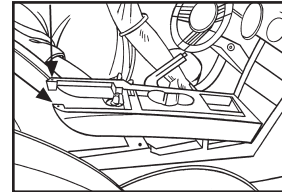

(Figura B)

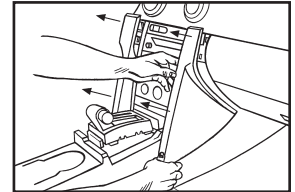

(Figura C)

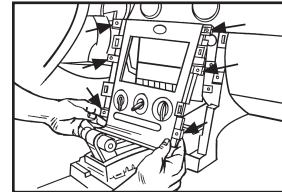

(Figura D)

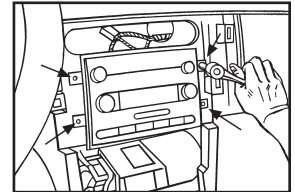

(Figura E)

## Desmontaje del tablero

Ford Five Hundred 2005-2007  
Ford Taurus 2008-2009  
Mercury Montego 2005-2007  
Mercury Sable 2008-2009

1. Desenganche y quite la pequeña moldura rectangular que rodea la palanca de velocidades. (Figura A)
2. Desenganche y quite todo el panel (incluyendo los portavasos) que rodea la palanca de velocidades. (Figura B)
3. Quite los (2) tornillos de 9/32" de la parte inferior del panel central de control del radio/clima. (Figura C)
4. Desenganche y quite el panel central. (Figura D)
5. Quite los (4) tornillos de 9/32" del radio para quitarlo. (Figura E)

Continúe con el ensamble del kit

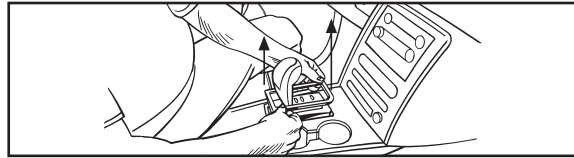

(Figura A)

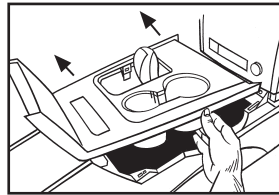

(Figura B)

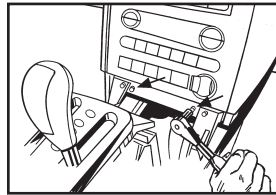

(Figura C)

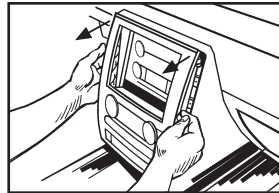

(Figura D)

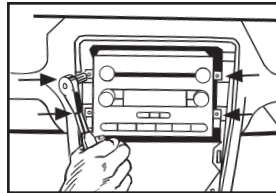

(Figura E)

Ford Fusion 2006-2009  
Mercury Milan 2006-2009

1. Suelte a presión y quite todo el panel que rodea el radio y los controles del clima. (Figura A)
2. Quite los (4) tornillos de 9/32" para quitar el radio de fábrica. (Figura B)

Continúe con el ensamble del kit

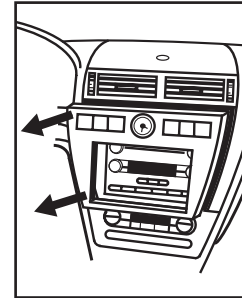

(Figura A)

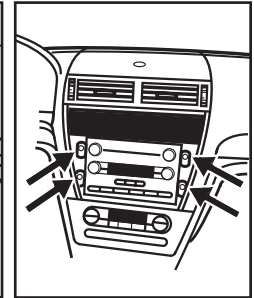

(Figura B)



## Desmontaje del tablero

**Ford Freestyle 2005-2007**  
**Ford Taurus X 2008-2009**

1. Soltar y retirar todo el panel que rodea la radio y los controles de A/C. (Figura A)
2. Quite los (4) tornillos de 9/32" del radio para quitarlo. (Figura B)

*Continúe con el ensamble del kit*

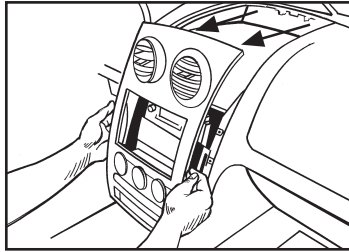

(Figura A)

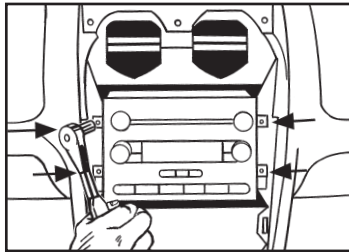

(Figura B)

**Ford Freestar 2004-2007**  
**Mercury Monterey 2004-2007**

1. Suelte a presión y quite todo el panel que rodea el radio y los controles del clima. (Figura A)
2. Quite los (4) tornillos de 9/32" para quitar el radio de fábrica. (Figura B)

*Continúe con el ensamble del kit*

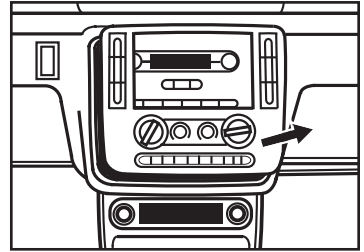

(Figura A)

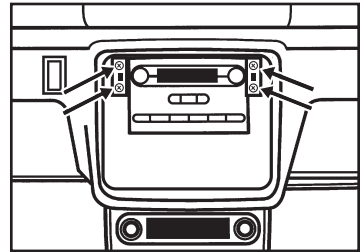

(Figura B)

## Desmontaje del tablero

### Ford Focus 2005-2007

1. Suelte a presión y quite todo el panel que rodea el radio y los controles del clima. (Figura A)
2. Quite los (4) tornillos de 9/32" para quitar el radio de fábrica. (Figura B)

*Continúe con el ensamble del kit*

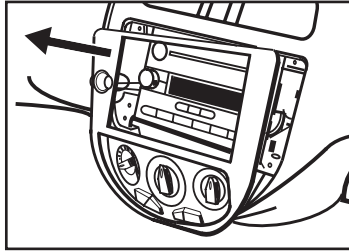

(Figura A)

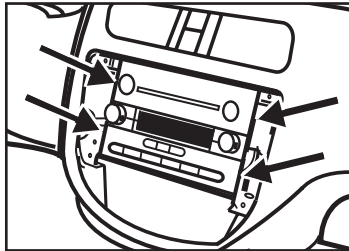

(Figura B)

### Ford Explorer/Explorer Sport Trac 2006-2010

### Mercury Mountaineer 2006-2010

1. Abra la consola central y retire los (2) tornillos Phillips, luego desenganche y quite todo el panel que rodea la palanca de velocidades. (Figura A)
2. Quite el panel del tablero que rodea el radio para tener acceso a los tornillos del radio de fábrica. (Figura B)
3. Quite los (4) tornillos de 9/32" para quitar el radio de fábrica. (Figura C)

*Continúe con el ensamble del kit*

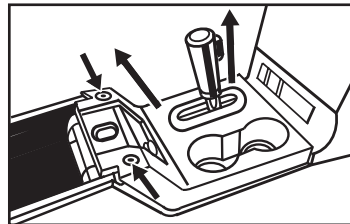

(Figura A)

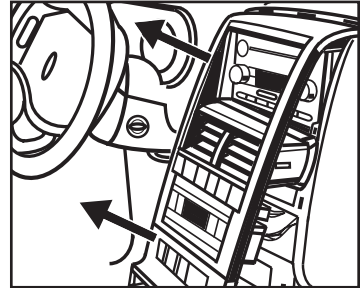

(Figura B)

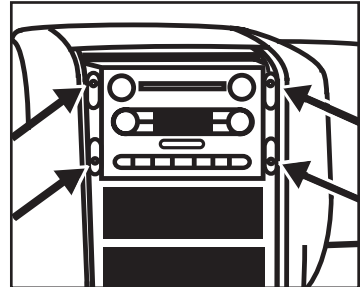

(Figura C)

## Desmontaje del tablero

### Ford Econoline (E-Series) 2009 y mas F-250/350/450/550 2005-2007

1. Suelte a presión y quite todo el panel que rodea el radio y los controles del clima. (Figura A)
2. Quite los (4) tornillos de 9/32" para quitar el radio de fábrica. (Figura B)

Continúe con el ensamble del kit

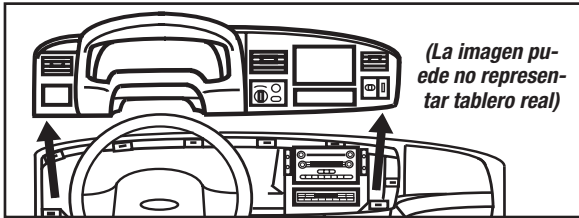

(La imagen puede no representar tablero real)

(Figura A)

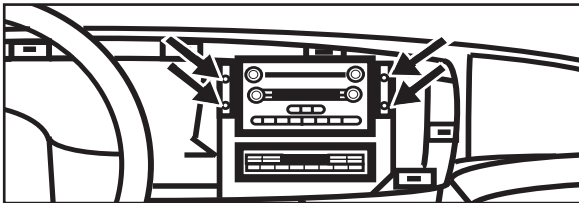

(Figura B)

### Ford F-250/350/450/550 2008-2012 F-250/350/450/550 (sin pantalla 8") 2013-2016 F-650/750 2011 y mas

1. Desenganche y quite el panel del tomacorriente y el panel de tapa del lado izquierdo y derecho del panel de la moldura del radio. (Figura A)
2. Quite los (2) tornillos de 9/32" expuestos detrás de los dos paneles que quitó anteriormente.
3. Desenganche y quite todo el panel de la moldura del radio, incluyendo el control y las rejillas del aire acondicionado.
4. Quite los (4) tornillos de 9/32" que sujetan el radio.

Continúe con el ensamble del kit

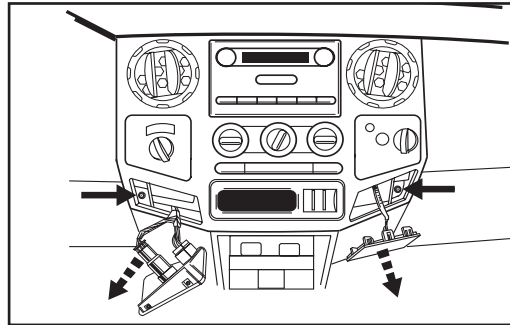

(Figura A)

### Ford Transit Connect 2013 Transit Connect (generación tardía) 2012

1. Quite el panel de la moldura del radio. (Figura A)
2. Quite los (4) tornillos que sujetan de radio y quite.

Continúe con el ensamble del kit

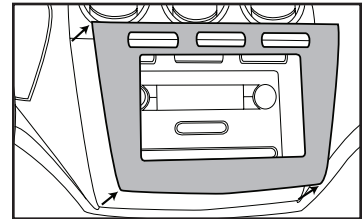

(Figura A)

## Desmontaje del tablero

### Lincoln MKX (con NAV) 2007-2010

1. Abra la tapa de la consola central y desenganche y quite el panel de la moldura de la consola central que rodea la palanca de velocidades. (Figura A)
2. Quite los (2) tornillos Phillips del cajón de almacenamiento y luego desenganche y quite el cajón. (Figura B)
3. Desenganche y quite el panel superior e inferior de la moldura central como un mismo ensamble. (Figura C)
4. Quite los (4) tornillos de 9/32" que sujetan el radio. Desconecte y quite el radio.

Continúe con el ensamble del kit

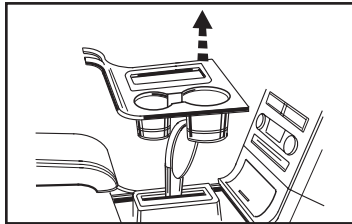

(Figura A)

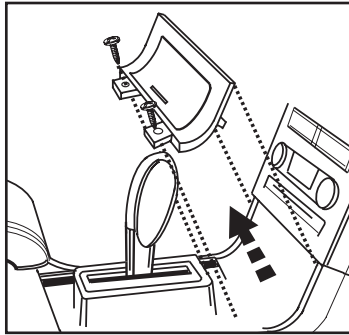

(Figura B)

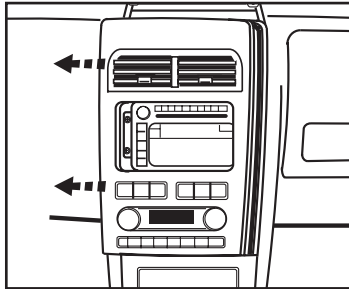

(Figura C)

### Lincoln Navigator (con NAV) 2007-2014

1. Desenganche y quite el panel que rodea la palanca de velocidades. (Figura A)
2. Quite los (2) tornillos de 9/32" de la parte inferior del panel de la moldura de control del radio/clima. (Figura B)
3. Desenganche y quite todo el panel que rodea el radio, incluyendo los controles del clima. (Figura B)
4. Quite los (4) tornillos de 9/32" que sujetan el radio. Desconecte y quite el radio.

Continúe con el ensamble del kit

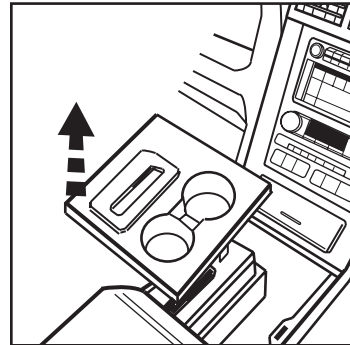

(Figura A)

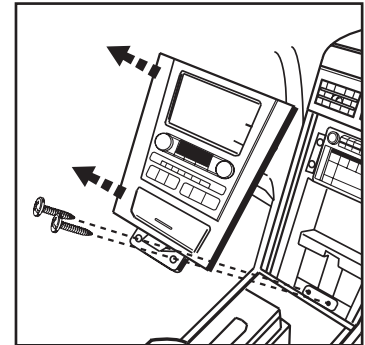

(Figura B)

## Ensamble del kit

### Provisión de radio DIN con bolsillo

1. (a) Para el **Ford Econoline 2009 y mas**, **Edge 2007-2010**, **Expedition 2007-2014**, **Expedition (flota) 2015**, **Explorer & Explorer Sport Trac 2006-2010**, **F-650/750 2011 y mas**, **F-250/350/450/550 2008-2016**, **F-150 2004-2008**, **Fusion 2006-2009**, **Transit Connect 2012-2013 / Lincoln Mark LT 2006-2008**, **MKX (con NAV) 2007-2010**, **Navigator (con NAV) 2007-2014 / Mercury Milan 2006-2009**, **Mountaineer 2006-2010**, acople los *separadores* incluidos para las lengüetas de montaje en la *carcasa del radio B*. Use los (4) tornillos suministrados para montar la carcasa al radio del vehículo. (Figura A)

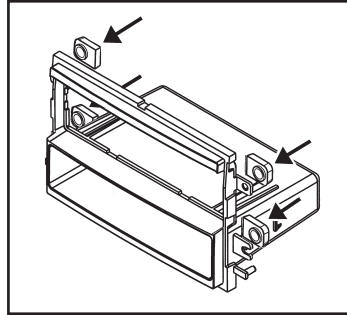

(Figura A)

- (b) Para el **Ford F-250/350/450/550 2005-2007**, **Focus 2005-2007**, **Freestar 2004-2007**, **Monterey 2004-2007**, deslice los *soportes laterales* en los lados de la *carcasa del radio B*. (Figura B)

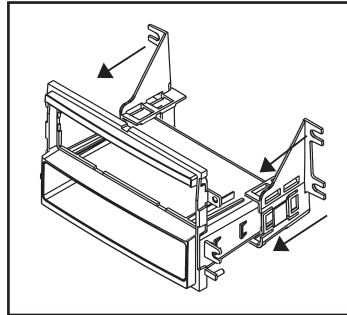

(Figura B)

- (c) Si su vehículo no aparece en las etapas (a) o (b), vaya al paso 2.

2. Quite la manga de metal DIN del radio de mercado secundario.
3. Deslice la manga en la *carcasa del radio B* y sujétela doblando hacia abajo las pestañas de metal. (Figura C)
4. Deslice el radio en la manga hasta que entre a presión. (Figura D)
5. Localice el arnés de cables de fábrica en el tablero. Metra recomienda el uso de un adaptador adecuado de acoplamiento de Metra o de AXCESS. Test the radio for proper operation.
6. Vuelva a armar el tablero al revés de como lo desarmó.

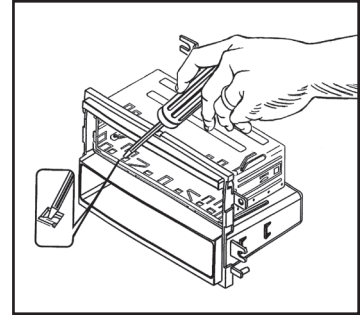

(Figura C)

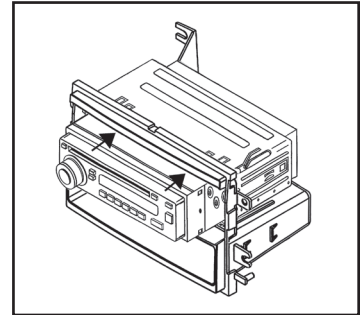

(Figura D)

## Ensamble del kit

### Provisión de radio ISO DIN con bolsillo

1. (a) Para el **Ford Econoline 2009 y mas, Edge 2007-2010, Expedition 2007-2014, Expedition (flota) 2015, Explorer & Explorer Sport Trac 2006-2010, F-650/750 2011 y mas, F-250/350/450/550 2008-2016, F-150 2004-2008, Fusion 2006-2009, Transit Connect 2012-2013 / Lincoln Mark LT 2006-2008, MKX (con NAV) 2007-2010, Navigator (con NAV) 2007-2014 / Mercury Milan 2006-2009, Mountaineer 2006-2010**, acople los *separadores* incluidos para las lengüetas de montaje en la *carcasa del radio B*. Use los (4) tornillos suministrados para montar la carcasa de la radio del vehículo. (Figura A)

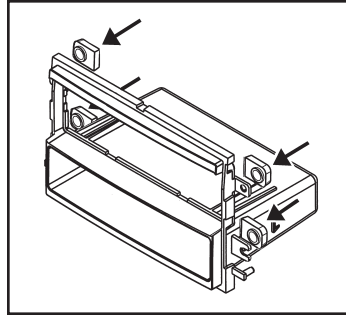

(Figura A)

- (b) Para el **Ford F-250/350/450/550 2005-2007, Focus 2005-2007, Freestar 2004-2007, Monterey 2004-2007**, deslice los *soportes laterales* en los lados de la *carcasa del radio B*. (Figura B)

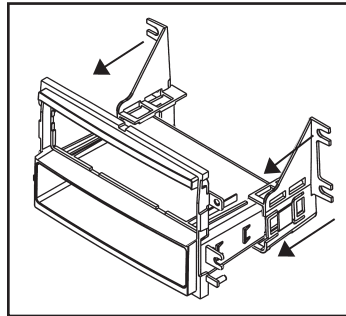

(Figura B)

- (c) Si su vehículo no aparece en las etapas (a) o (b), vaya al paso 2.

- Quite la manga de metal DIN y el anillo de moldura del radio de mercado secundario.
- Monte los *soportes ISO* en el radio con los tornillos que vienen con el radio. (Figura C)
- Deslice la radio en la abertura de radio hasta que los ganchos laterales se acoplan. (Figura D)
- Coloque la *placa de ajuste* en la *carcasa del radio B*. (Figura D)
- Localice el arnés de cables de fábrica en el tablero. Metra recomienda el uso de un adaptador adecuado de acoplamiento de Metra o de AXCESS. Test the radio for proper operation.
- Vuelva a armar el tablero al revés de como lo desarmó.

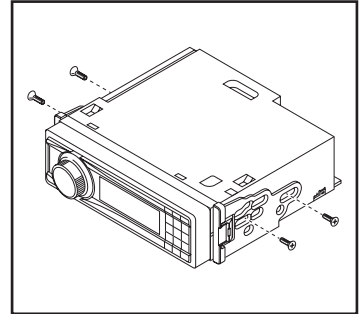

(Figura C)

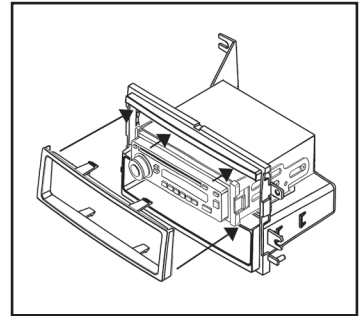

(Figura D)

## Ensamble del kit

### Provisión de radio ISO DDIN

1. Conecte los *soportes ISO DDIN* a la carcasa de radio A. (Figura A)
2. (a) Para el **Ford Econoline 2009 y mas, Edge 2007-2010, Expedition 2007-2014, Expedition (flota) 2015, Explorer & Explorer Sport Trac 2006-2010, F-650/750 2011 y mas, F-250/350/450/550 2008-2016, F-150 2004-2008, Fusion 2006-2009, Transit Connect 2012-2013 / Lincoln Mark LT 2006-2008, MKX (con NAV) 2007-2010, Navigator (con NAV) 2007-2014 / Mercury Milan 2006-2009, Mountaineer 2006-2010**, coloque los *espaciadores* en las lengüetas de montaje frontales (Figura B). A continuación, corte y retire las lengüetas de montaje traseras de los soportes (Figura C). Utilice los (4) tornillos suministrados para asegurar la carcasa de la radio al vehículo.

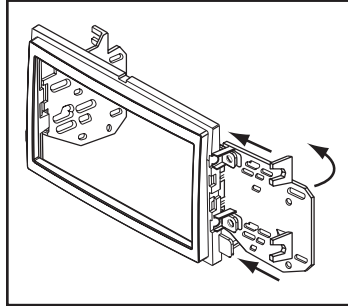

(Figura A)

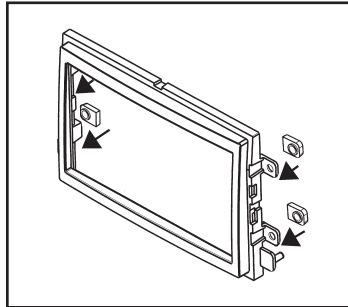

(Figura B)

- (b) Para el **Ford Five Hundred 2005-2007, Freestyle 2005-2007, Mustang 2005-2009, Taurus & Taurus X 2008-2009 / Mercury Montego 2005-2007, Sable 2008-2009**, Corte y retire las lengüetas de montaje traseras de los soportes. (Figura C)

(c) Si su vehículo no aparece en las etapas (a) o (b), vaya al paso 2.

3. Deslice la radio en el carcasa del radio B y asegure utilizando los tornillos suministrados con la radio. (Figura C)
4. Localice el arnés de cables de fábrica en el tablero. Metra recomienda el uso de un adaptador adecuado de acoplamiento de Metra o de AXCESS. Test the radio for proper operation.
5. Vuelva a armar el tablero al revés de como lo desarmó.

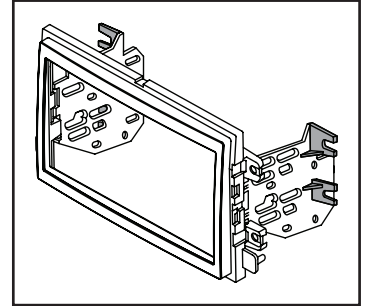

(Figura C)

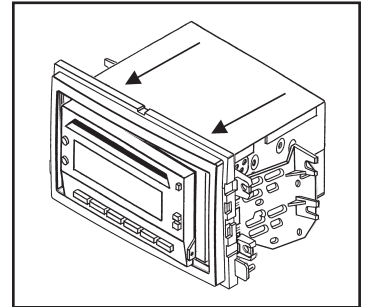

(Figura D)



Instrucciones de instalación para la pieza 95-5812 o 99-5812



## IMPORTANTE

Si tiene dificultades con la instalación de este producto, llame a nuestra línea de soporte técnico al **1-800-253-TECH**. Antes de hacerlo, revise las instrucciones por segunda vez y asegúrese de que la instalación se haya realizado exactamente como se indica en las instrucciones. Por favor tenga el vehículo desarmado y listo para ejecutar los pasos de resolución de problemas antes de llamar.



**EL CONOCIMIENTO ES PODER**  
Mejore sus habilidades de instalación y fabricación inscribiéndose en la escuela de dispositivos electrónicos móviles más reconocida y respetada de nuestra industria. Regístrese en [www.installerinstitute.com](http://www.installerinstitute.com) o llame al 800-354-6782 para obtener más información y avance hacia un futuro mejor.



**Metra recomienda técnicos con certificación del Programa de Certificación en Electrónica Móvil (Mobile Electronics Certification Program, MECP).**

REV. 3/20/2018 INST-5812