



Installation instructions for part 99-5027

U.S. PATENT # D711,869

Ford/Mazda multi-kit 1995-2011 99-5027 / AT-586FT / FDDK1 / CF-586FT / IBR-527FD

KIT FEATURES

- DIN radio provision with pocket
- ISO DIN radio provision with pocket



KIT COMPONENTS

- A) Radio housing • B) Radio housing trim piece "A" • C) Radio housing trim piece "B" • D) ISO Brackets
- E) Rear support • F) ISO Trim plate • G) Mounting bracket • H) (4) #8 x 3/8" Phillips screws

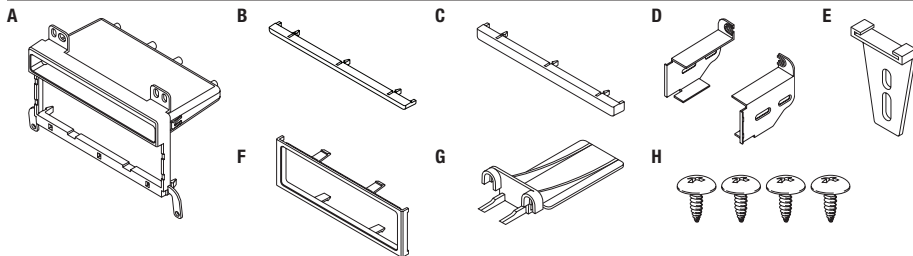

APPLICATIONS

See application list inside cover

WIRING & ANTENNA CONNECTIONS (sold separately)

Wiring Harness:

- Please visit www.metraonline.com for specific interface applications

Antenna Adapter:

- Not required

TOOLS REQUIRED

- Panel removal tool • Phillips screwdriver
- 86-5618 Ford radio removal keys

CAUTION! All accessories, switches, climate controls panels, and especially air bag indicator lights must be connected before cycling the ignition. Also, do not remove the factory radio with the key in the on position, or while the vehicle is running.

REV. 6/13/2018 INST-99-5027

Applications

Ford

Crown Victoria	1995-2011
Econoline	1997-2008
Expedition	1997-2002
Expedition (<i>without NAV</i>).....	2003-2006
Explorer	1995-2005
F-150	1997-2003
F-150 (<i>Heritage</i>).....	2004
F-350	1999-2004
F-550	1999-2004
Mustang	2001-2004
Ranger	1995-2011
Windstar	1999-2003
Excursion	2000-2005

Lincoln

Aviator	2003-2005
Continental	1995-1997
Blackwood	2002
Mark 8	1996-1998
Town Car	1995-2002
Navigator	1997-2002
Navigator (<i>with NAV, THX amp</i>)...	2003-2006
Navigator (<i>without NAV</i>).....	2003-2006

Mazda

B-Series Pickup	1995-2009
-----------------------	-----------

Mercury

Grand Marquis	1995-2010
Mountaineer	1997-2005
Marauder	2003-2004
Mariner	2005-2007

Table of Contents

Dash Disassembly

Ford

– Crown Victoria 1995-2011.....	3
– Econoline 1997-2008	3
– Excursion 2000-2005	4
– Expedition 1997-2002.....	4
– Expedition (<i>without NAV</i>) 2003-2006	5
– Explorer 1995-2001	3
– Explorer 2002-2005	5
– F-150 1997-2003.....	4
– F-150 (<i>Heritage</i>) 2004	4
– F-250 1998	4
– F-250 1999-2004.....	3
– F-350 1999-2004.....	3
– F-550 1999-2004.....	3
– Mustang 2001-2004.....	5
– Ranger 1995-2011	3

Lincoln

– Aviator 2003-2005	7
– Blackwood 2002.....	4
– Continental 1995-1997.....	3

Lincoln (Cont)

– Mark 8 1996-1998	3
– Navigator 1997-2002	3
– Navigator (<i>with NAV, THX amp</i>) 2003-2006	6
– Navigator (<i>without NAV</i>) 2003-2006	6
– Town Car 1995-2002.....	3

Mazda

– B-Series Pickup 1995-2009	3
-----------------------------------	---

Mercury

– Grand Marquis 1995-2010	3
– Marauder 2003-2004	3
– Mariner 2005-2007	3
– Mountaineer 1997-2001.....	3
– Mountaineer 2002-2005.....	5

Kit Preparation

Kit Assembly

– DIN radio provision with pocket.....	9, 11
– ISO DIN radio provision with pocket	10, 12

Dash Disassembly

Ford Crown Victoria 1995-2011/Econoline 1997-2008/Explorer 1995-2001/F-250 1999-2004/ F-350 1999-2004/F-550 1999-2004/Ranger 1995-2011, Lincoln Continental 1995-1997/Mark 8 1996-1998/Town Car 1995-2002, Mazda B-Series Pickup 1995-2009, Mercury Grand Marquis 1995-2010/Marauder 2003-2004/Mariner 2005-2007/Mountaineer 1997-2001

1. Using Metra's 86-5618, pull the factory radio from the dash and disconnect the wiring. (Figure A)
2. Cut and remove the top mounting legs "A" and the bottom mounting legs "B" from the radio housing. (Figure B)

Continue to kit preparation

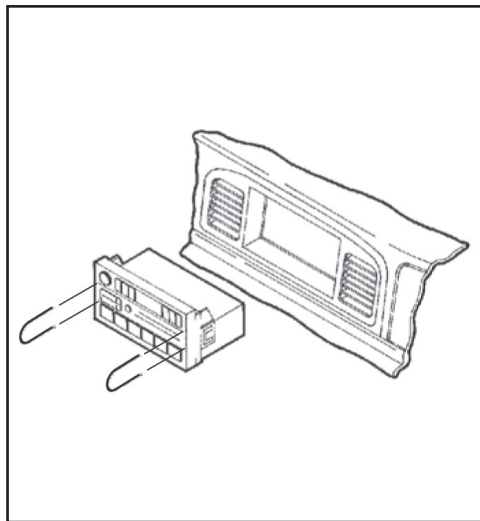

(Figure A)

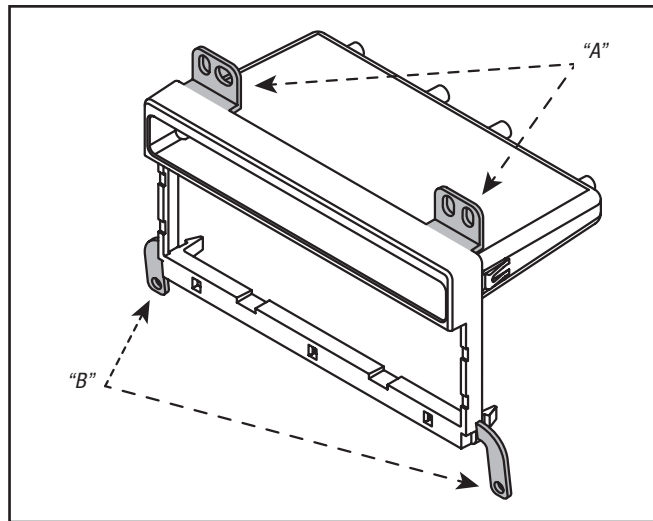

(Figure B)

Dash Disassembly

**Ford Expedition 1997-2002/F-150 1997-2003/
F-150 (Heritage) 2004/F-250 1998
Excursion 2000-2005, Lincoln Blackwood
2002/Navigator 1997-2002**

1. Place your index fingers on the inner edges of the A/C vents and push inward. Grasp the exposed lip of each vent opening and pull out on the radio trim bezel. Remove the dash trim bezel (airbag wiring does **not** need to be disconnected). (Figure A)
2. Using Metra's 86-5618, pull the factory radio from the dash and disconnect the wiring.
3. Remove the (2) uppermost mounting screws from the climate control panel.
4. Cut and remove the top mounting legs "A" from the radio housing. (Figure B)

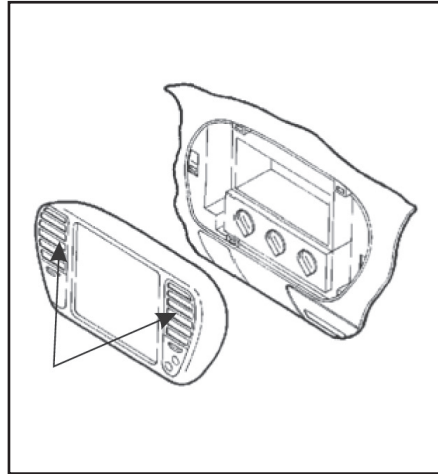

(Figure A)

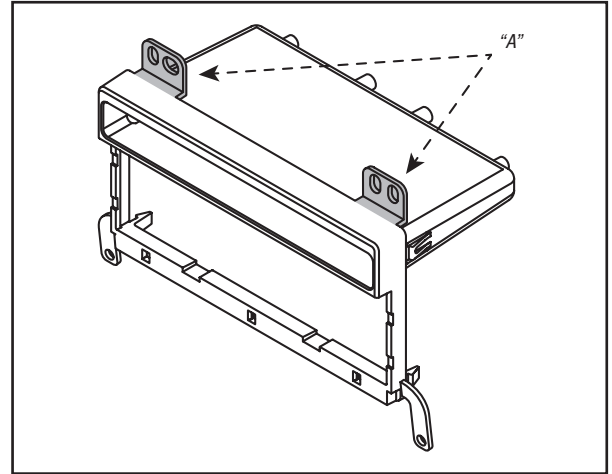

(Figure B)

Note: For the Ford Expedition 1997-1998, F-150 1997-1998, F-250 1998 remove the rear support bracket from the dash cavity.

Continue to kit preparation

Dash Disassembly

Ford Expedition (without NAV) 2003-2006

1. Remove (2) 9/32" screws from above instrument cluster. (Figure A)
2. Unclip and remove entire panel surrounding radio, climate controls, and instrument cluster. (Figure B)
3. Remove (2) 9/32" screws securing radio.

Continue to kit preparation

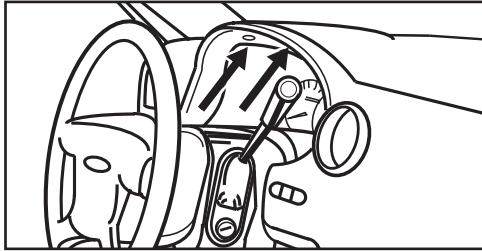

(Figure A)

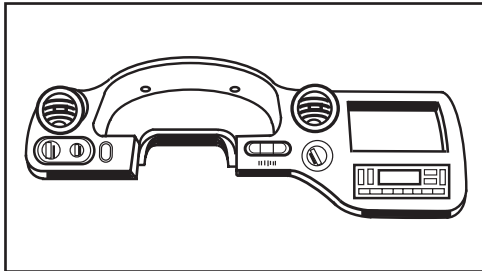

(Figure B)

Ford Explorer 2002-2005 Mercury Mountaineer 2002-2005

1. Unclip and remove entire panel surrounding radio including climate controls and vents. (Figure A)
2. Remove (2) 9/32" screws securing radio. (Figure B)

Continue to kit preparation

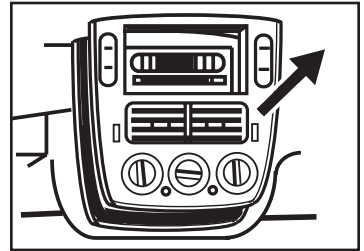

(Figure A)

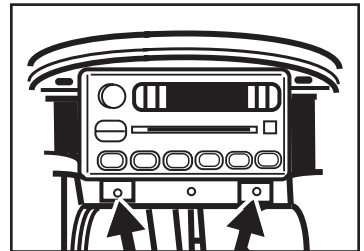

(Figure B)

Dash Disassembly

Ford Mustang 2001-2004

1. Unclip and remove shift lever trim panel. (Figure A)
2. Unclip and remove the entire panel surrounding the radio and climate controls including the vents. (Figure B)
3. Remove (2) 9/32" screws securing radio. (Figure B)

Continue to kit preparation

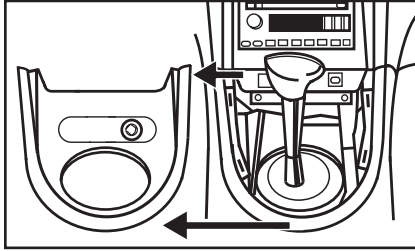

(Figure A)

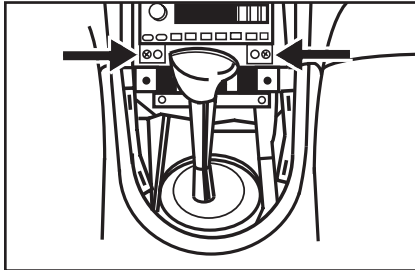

(Figure B)

Lincoln Aviator 2003-2005

1. Unclip and remove vent panel above radio on top of dashboard. (Figure A)
2. Remove (2) 9/32" screws exposed under panel removed in step 1. (Figure B)
3. Unclip and remove panel around radio with door in it. (Figure C)

Continued on the next page

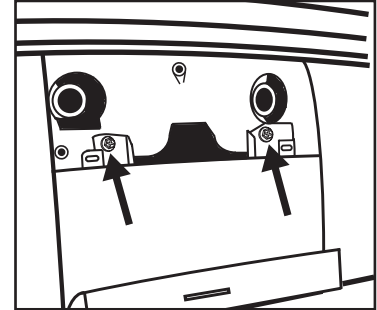

(Figure B)

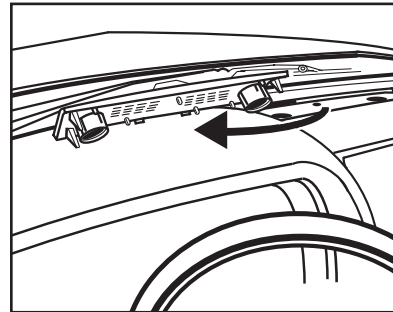

(Figure A)



(Figure C)

Dash Disassembly

Lincoln Aviator 2003-2005 (Cont)

4. Unclip and remove vents below radio. (Figure D)
5. Remove (2) 9/32" screws securing radio. (Figure E)

Continue to kit preparation

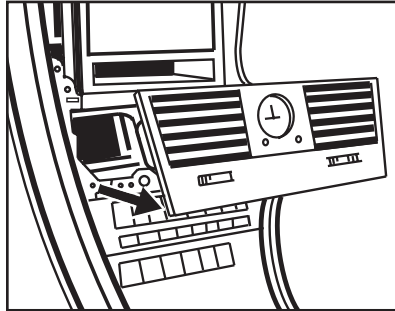

(Figure D)

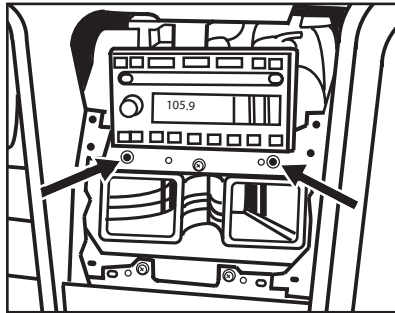

(Figure E)

Lincoln Navigator

(with NAV, THX amp) 2003-2006
Navigator (without NAV) 2003-2006

1. Open center console and remove (1) push pin from back of power window switch panel. (Figure A)
2. Unclip and remove panel.
3. Remove (2) 9/32" screws exposed on shifter panel then unclip and move shifter panel off to side. (Figure B, C)
4. Remove (2) 9/32" screws exposed under ashtray assembly. (Figure C)
5. Unclip and remove entire panel surrounding climate controls and radio.
6. Remove (2) 9/32" screws securing radio. (Figure C)

Continue to kit preparation

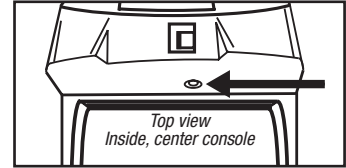

(Figure A)

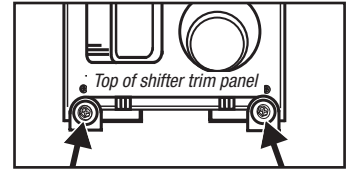

(Figure B)

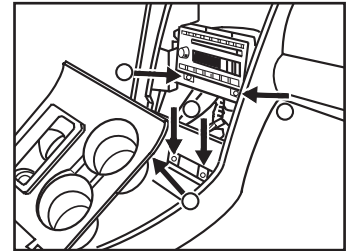

(Figure C)

Kit Preparation

1. Attach the corresponding *radio housing trim piece* to the radio housing. (Figure A)

The following applications will use *radio housing trim piece “B” (thicker trim piece)*:

Ford Expedition (without NAV) 2003-2006

Ford Explorer 2002-2005

Ford Mustang 2001-2004

Lincoln Aviator 2003-2005

Lincoln Navigator (without NAV) 2003-2006

Lincoln Navigator (with NAV, with THX amp) 2003-2006

Mercury Mountaineer 2002-2005

2. Cut and remove the mounting legs (B) from the radio housing. (Figure A)

Note: *The kit is illustrated upside down of how it will actually mount into the vehicle.*

Continue to kit assembly, pages 9-10

All other applications will use *radio housing trim piece “A” (thinner trim piece)*:

Continue to kit assembly, pages 11-12

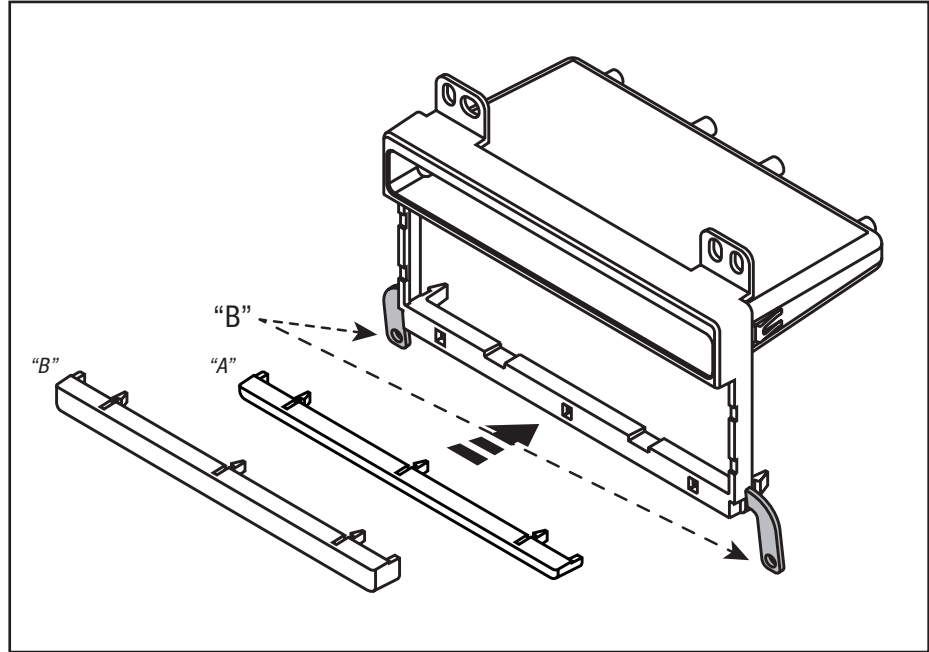

(Figure A)

Kit Assembly

DIN radio provision with pocket

1. Remove the metal DIN sleeve from the aftermarket radio.
2. Slide the sleeve into the *radio housing* and secure by bending the metal locking tabs down.
3. Slide the radio into the sleeve until it clicks in.
4. Secure the *mounting bracket* to the back of the *radio housing* with the (2) #8 x 3/8" Phillips screws supplied. (Figure A)

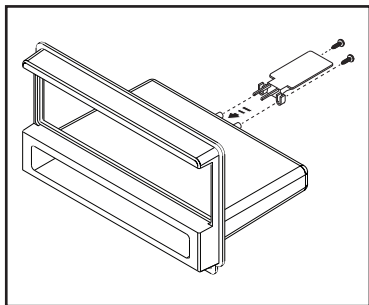

(Figure A)

5. Slide the *rear support* onto the *mounting bracket*, and then mount the support to the back of the radio using the hardware included with the radio. (Figure B)

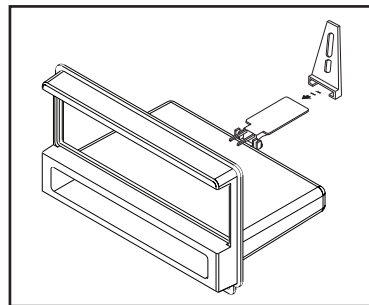

(Figure B)

Note: For the Ford Expedition and Lincoln Navigator, cut the support as shown in Figure C. (Figure C)

6. Locate the factory wiring harness and antenna connector in the dash. Metra recommends using the proper mating adapter from Metra or AXCESS. Test the radio for proper operation.
7. Reassemble the dash in reverse order of disassembly.

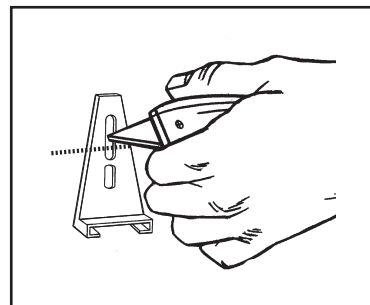

(Figure C)

Kit Assembly

ISO DIN radio provision with pocket

1. Attach the *ISO brackets* to the *radio housing*, and then secure using the (2) #8 x 3/8" Phillips screws provided and then snap the correct *radio housing trim piece* to the *radio housing*. (Figure A)
2. Remove the metal DIN sleeve and trim ring from the aftermarket radio.
3. Slide the radio into the rear of the radio opening and then secure with the screws supplied with the radio. (Figure B)
4. Snap the *trim plate* into the radio housing. (Figure B)
5. Locate the factory wiring harness and antenna connector in the dash. Metra recommends using the proper mating adapter from Metra or AXCESS. Test the radio for proper operation.
6. Reassemble the dash in reverse order of disassembly.

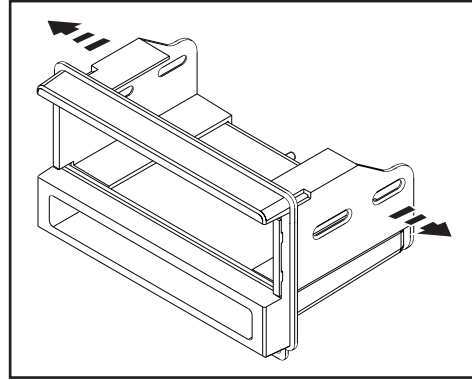

(Figure A)

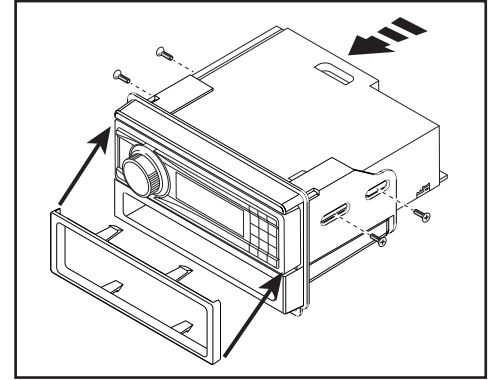

(Figure B)

Kit Assembly

DIN radio provision with pocket

1. Remove the metal DIN sleeve from the aftermarket radio.
2. Slide the sleeve into the *radio housing* and secure by bending the metal locking tabs down.
3. Slide the radio into the sleeve until it clicks in.
4. Secure the *mounting bracket* to the back of the *radio housing* with the (2) #8 x 3/8" Phillips screws supplied. (Figure A)
5. Slide the *rear support* onto the *mounting bracket*, and then mount the support to the back of the radio using the hardware included with the radio. (Figure A)
6. Locate the factory wiring harness and antenna connector in the dash. Metra recommends using the proper mating adapter from Metra or AXCESS. Test the radio for proper operation.
7. Reassemble the dash in reverse order of disassembly.

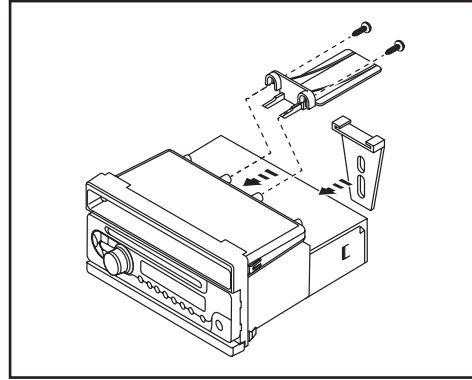

(Figure A)

Kit Assembly

ISO DIN radio provision with pocket

1. Attach the *ISO brackets* to the *radio housing*, and then secure using the (2) #8 x 3/8" Phillips screws provided. (Figure A)
2. Remove the metal DIN sleeve and trim ring from the aftermarket radio.
3. Slide the radio into the rear of the radio opening and then secure with the screws supplied with the radio. (Figure B)
4. Snap the *trim plate* into the radio housing. (Figure B)
5. Locate the factory wiring harness and antenna connector in the dash. Metra recommends using the proper mating adapter from Metra or AXXESS. Test the radio for proper operation.
6. Reassemble the dash in reverse order of disassembly.

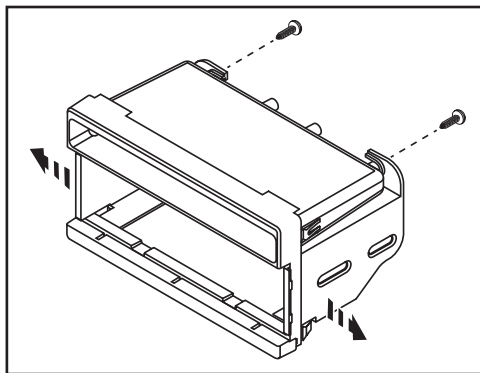

(Figure A)

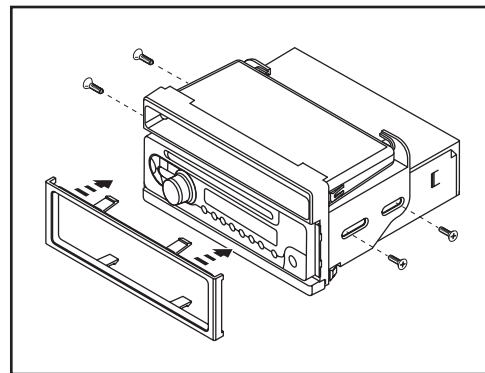

(Figure B)

Notes



99-5027

Notes



Installation instructions for part 99-5027



IMPORTANT

If you are having difficulties with the installation of this product, please call our Tech Support line at **1-800-253-TECH**. Before doing so, look over the instructions a second time, and make sure the installation was performed exactly as the instructions are stated. Please have the vehicle apart and ready to perform troubleshooting steps before calling.



KNOWLEDGE IS POWER

Enhance your installation and fabrication skills by enrolling in the most recognized and respected mobile electronics school in our industry. Log onto www.installerinstitute.com or call 800-354-6782 for more information and take steps toward a better tomorrow.



**Metra recommends MECP
certified technicians**

REV. 6/13/2018 INST-99-5027



Instrucciones de instalación para la pieza 99-5027

U.S. PATENT # D711,869

Ford/Mazda multi-kit 1995-2011 99-5027 / AT-586FT / FDDK1 / CF-586FT / IBR-527FD

CARACTERÍSTICAS DEL KIT

- Provisión de radio DIN con bolsillo
- Provisión de radio ISO DIN con bolsillo



COMPONENTES DEL KIT

- A) Carcasa del radio • B) Moldura de la carcasa del radio, pieza "A"
- C) Moldura de la carcasa del radio, pieza "B" • D) Soportes ISO • E) Soporte trasero
- F) Placa de moldura ISO • G) Soporte de montaje • H) (4) tornillos Phillips de cabeza segmentada #8 x 3/8"

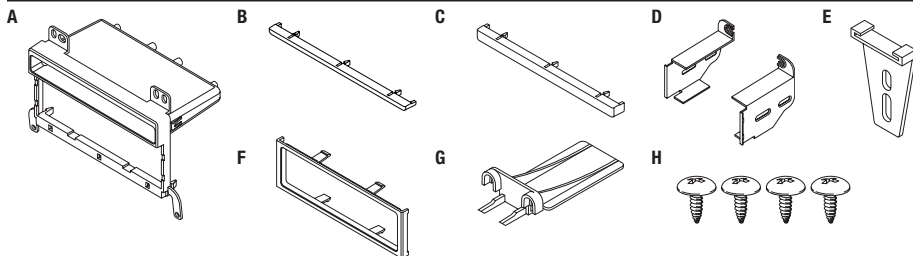

APLICACIONES

Ver interior de la portada

CABLEADO Y CONEXIONES DE ANTENA

Arnés de cableado: (se venden por separado)

- Visite metraonline.com para aplicaciones de interfaz específicas

Adaptador de antena:

- No se requiere

HERRAMIENTAS REQUERIDAS

- Herramienta de remoción de panel
- Destornillador Phillips
- Llaves de remoción Ford 86-5618

¡PRECAUCIÓN! Todos los accesorios, interruptores, paneles de controles de clima y especialmente las luces del indicador de las bolsas de aire deben estar conectados antes ciclar la ignición. Además, no quite el radio de fábrica con la llave en la posición o de encendido ni con el vehículo funcionando.

REV. 6/13/2018 INST-99-5027

Aplicaciones

Ford

Crown Victoria	1995-2011
Econoline	1997-2008
Expedition	1997-2002
Expedition (<i>sin NAV</i>).....	2003-2006
Explorer	1995-2005
F-150	1997-2003
F-150 (<i>Heritage</i>).....	2004
F-350	1999-2004
F-550	1999-2004
Mustang	2001-2004
Ranger	1995-2011
Windstar	1999-2003
Excursion	2000-2005

Lincoln

Aviator	2003-2005
Continental	1995-1997
Blackwood	2002
Mark 8	1996-1998
Town Car	1995-2002
Navigator	1997-2002
Navigator (<i>con NAV, amp THX</i>)....	2003-2006
Navigator (<i>sin NAV</i>).....	2003-2006

Mazda

B-Series Pickup	1995-2009
-----------------------	-----------

Mercury

Grand Marquis	1995-2010
Mountaineer	1997-2005
Marauder	2003-2004
Mariner	2005-2007

Indice

Desmontaje del tablero

Ford

– Crown Victoria 1995-2011	3
– Econoline 1997-2008	3
– Excursion 2000-2005	4
– Expedition 1997-2002	4
– Expedition (<i>sin NAV</i>) 2003-2006	5
– Explorer 1995-2001	3
– Explorer 2002-2005	5
– F-150 1997-2003.....	4
– F-150 (<i>Heritage</i>) 2004	4
– F-250 1998	4
– F-250 1999-2004.....	3
– F-350 1999-2004.....	3
– F-550 1999-2004.....	3
– Mustang 2001-2004.....	5
– Ranger 1995-2011	3

Lincoln

– Aviator 2003-2005	7
– Blackwood 2002.....	4
– Continental 1995-1997.....	3

Lincoln (Cont)

– Mark 8 1996-1998	3
– Navigator 1997-2002	3
– Navigator (<i>con NAV, amp THX</i>) 2003-2006.....	6
– Navigator (<i>sin NAV</i>) 2003-2006	6
– Town Car 1995-2002.....	3

Mazda

– B-Series Pickup 1995-2009	3
-----------------------------------	---

Mercury

– Grand Marquis 1995-2010	3
– Marauder 2003-2004	3
– Mariner 2005-2007	3
– Mountaineer 1997-2001.....	3
– Mountaineer 2002-2005.....	5

Preparación del kit

Ensamble del kit

– Provisión de radio DIN con cavidad	9, 11
– Provisión de radio ISO DIN con cavidad	10, 12

Desmontaje del tablero

Ford Crown Victoria 1995-2011/Econoline 1997-2008/Explorer 1995-2001/F-250 1999-2004/ F-350 1999-2004/F-550 1999-2004/Ranger 1995-2011,
Lincoln Continental 1995-1997/Mark 8 1996-1998/Town Car 1995-2002,
Mazda B-Series Pickup 1995-2009,
Mercury Grand Marquis 1995-2010/Marauder 2003-2004/Mariner 2005-2007/Mountaineer 1997-2001

1. Usando las llaves 86-5618 de Metra, jale la unidad central de fábrica del tablero y desconecte el cableado. (Figura A)
2. Corte y quite la patas de montaje superior "A" y las patas de montaje inferior "B" de la carcasa del radio. (Figura B)

Continúe con la preparación del kit

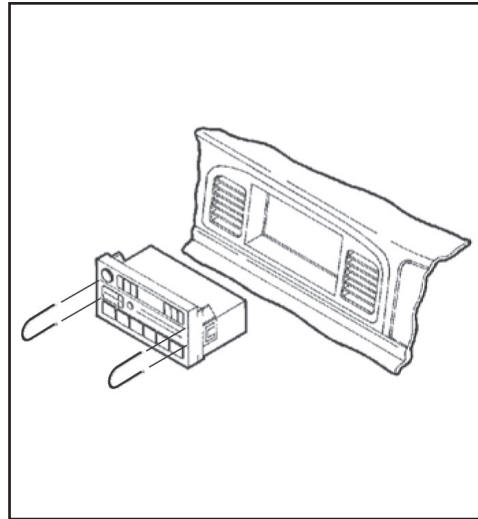

(Figura A)

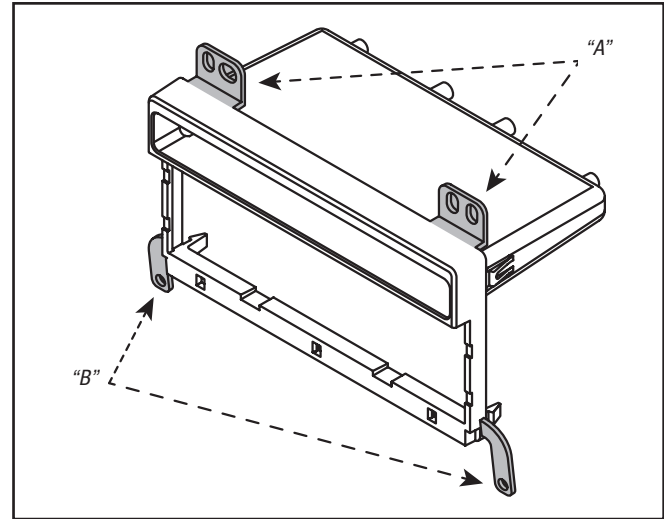

(Figura B)

Desmontaje del tablero

**Ford Expedition 1997-2002/F-150 1997-2003/
F-150 (Heritage) 2004/F-250 1998
Excursion 2000-2005, Lincoln Blackwood
2002/Navigator 1997-2002**

1. Coloque sus dedos índices en los bordes internos de las rejillas del aire acondicionado y jale hacia adentro. Sujete el borde expuesto de cada apertura de rejilla y jale hacia afuera el bisel de la moldura del radio. Quite el bisel de la moldura del tablero (no es necesario desconectar el cableado de la bolsa de aire). (Figura A)
2. Usando las llaves 86-5618 de Metra, jale la unidad central de fábrica del tablero y desconecte el cableado.
3. Quite los tornillos (2) de montaje superior del panel de control climático.
4. Corte y quite las patas de montaje superior "A" de la carcasa del radio. (Figura B)

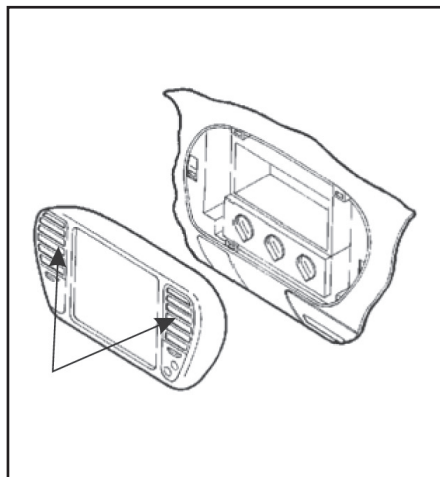

(Figura A)

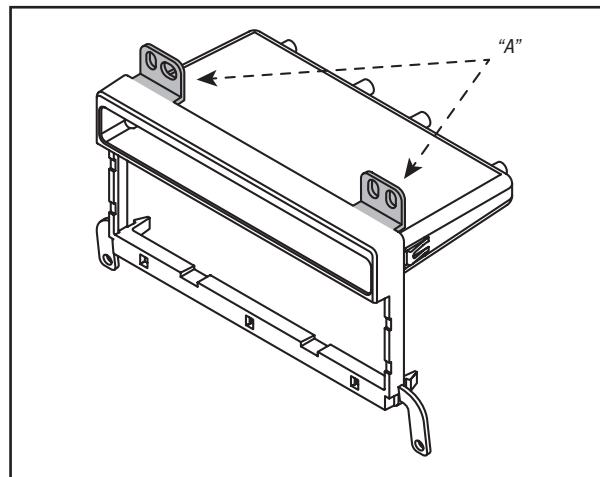

(Figura B)

Nota: Para la Ford Expedition 1997-1998, F-150 1997-1998, F-250 1998 retire el soporte de apoyo trasero de la cavidad del tablero.

Continúe con la preparación del kit

Desmontaje del tablero

Ford Expedition (sin NAV) 2003-2006

1. Quite los (2) tornillos de 9/32" de arriba del conjunto de instrumentos. (Figura A)
2. Desenganche y quite todo el panel que rodea el radio, los controles del clima y el conjunto de instrumentos. (Figura B)
3. Retire los (2) tornillos de 9/32" que sostienen el radio.

Continúe con la preparación del kit

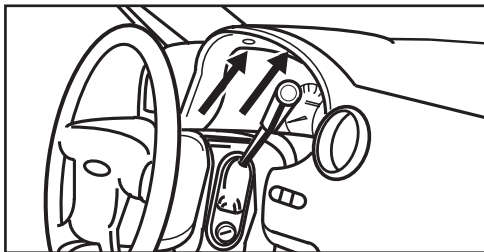

(Figura A)

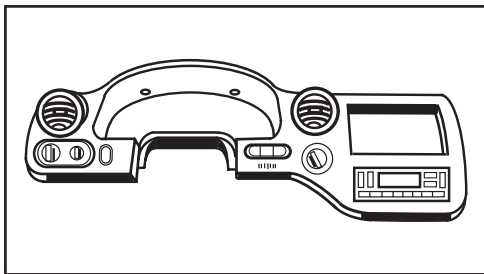

(Figura B)

Ford Explorer 2002-2005 Mercury Mountaineer 2002-2005

1. Desenganche y quite todo el panel que rodea el radio, incluyendo los controles del clima y las rejillas. (Figura A)
2. Retire los (2) tornillos de 9/32" que sostienen el radio. (Figura B)

Continúe con la preparación del kit

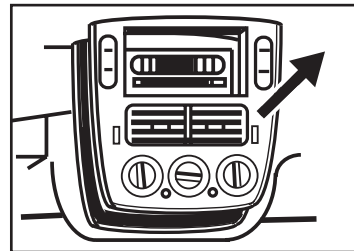

(Figura A)

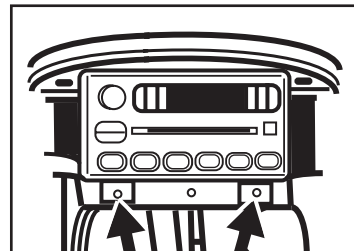

(Figura B)

Desmontaje del tablero

Ford Mustang 2001-2004

1. Desenganche y quite el panel de la moldura de la palanca de velocidades. (Figura A)
2. Desenganche y retire todo el panel que rodea el radio y los controles del clima, incluyendo las rejillas. (Figura B)
3. Retire los (2) tornillos de 9/32" que sostienen el radio. (Figura B)

Continúe con la preparación del kit

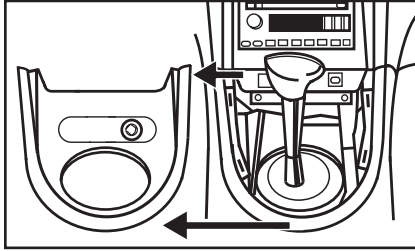

(Figura A)

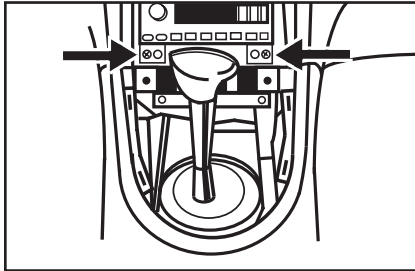

(Figura B)

Lincoln Aviator 2003-2005

1. Desenganche y quite el panel de la rejilla arriba del radio sobre el tablero. (Figura A)
2. Quite los (2) tornillos de 9/32" expuestos debajo del panel que quitó en el paso 1. (Figura B)
3. Desenganche y quite el panel que rodea el radio con la puerta incluida. (Figura C)

Continúa en la siguiente página

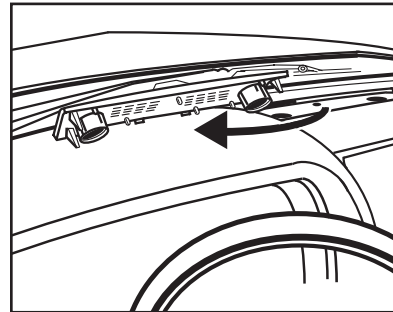

(Figura A)

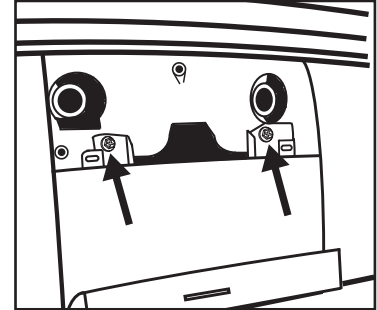

(Figura B)



(Figura C)

Desmontaje del tablero

Lincoln Aviator 2003-2005 (Cont)

- Desenganche y quite las rejillas debajo del radio. (Figura D)
- Retire los (2) tornillos de 9/32" que sostienen el radio. (Figura E)

Continúe con la preparación del kit

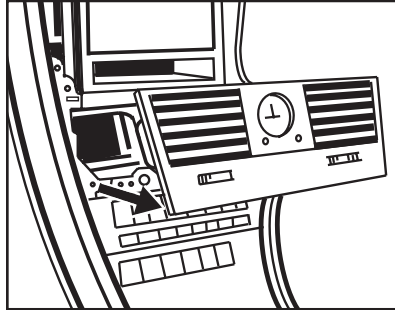

(Figura D)

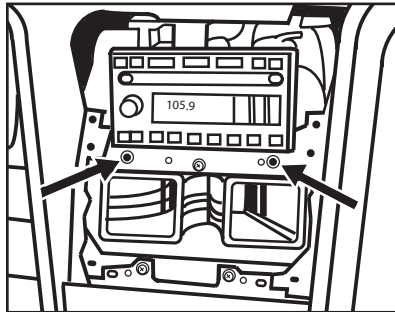

(Figura E)

Lincoln Navigator

(con NAV, amp THX) 2003-2006

Navigator (sin NAV) 2003-2006

- Abra la consola central y quite (1) chincheta de la parte posterior del panel interruptor de la ventanilla eléctrica. (Figura A)
- Desenganche y quite el panel.
- Quite los (2) tornillos de 9/32" expuestos del panel de la palanca de velocidades y luego desenganche y mueva la palanca de velocidades a un lado. (Figura B, C)
- Quite los (2) tornillos de 9/32" expuestos debajo del ensamble del cenicero. (Figura C)
- Desenganche y quite todo el panel que rodea los controles del clima y el radio.
- Retire los (2) tornillos de 9/32" que sostienen el radio. (Figura C)

Continúe con la preparación del kit



(Figura A)

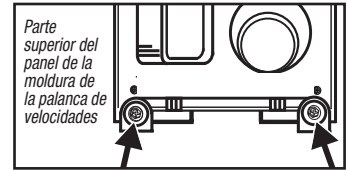

(Figura B)

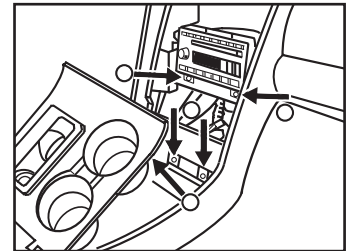

(Figura C)

Preparación del kit

1. Una la pieza correspondiente de la moldura de la carcasa del radio a la carcasa del radio. (Figura A)

Las siguientes aplicaciones utilizarán la pieza "B" de la moldura de la carcasa del radio (*pieza más gruesa de moldura*):

Ford Expedition (sin NAV) 2003-2006

Ford Explorer 2002-2005

Ford Mustang 2001-2004

Lincoln Aviator 2003-2005

Lincoln Navigator (sin NAV) 2003-2006

Lincoln Navigator (sin NAV, with THX amp) 2003-2006

Mercury Mountaineer 2002-2005

2. Cortar y quitar las patas de montaje (B) (B) de la carcasa de la radio. (Figura A)

Nota: El kit se ilustra revés de lo que realmente va a montar en el vehículo.

Continúe con el ensamble del kit, páginas 9-10

Todas las demás aplicaciones utilizarán la pieza "A" de la moldura de la carcasa del radio (*pieza más delgada de moldura*):

Continúe con el ensamble del kit, páginas 11-12

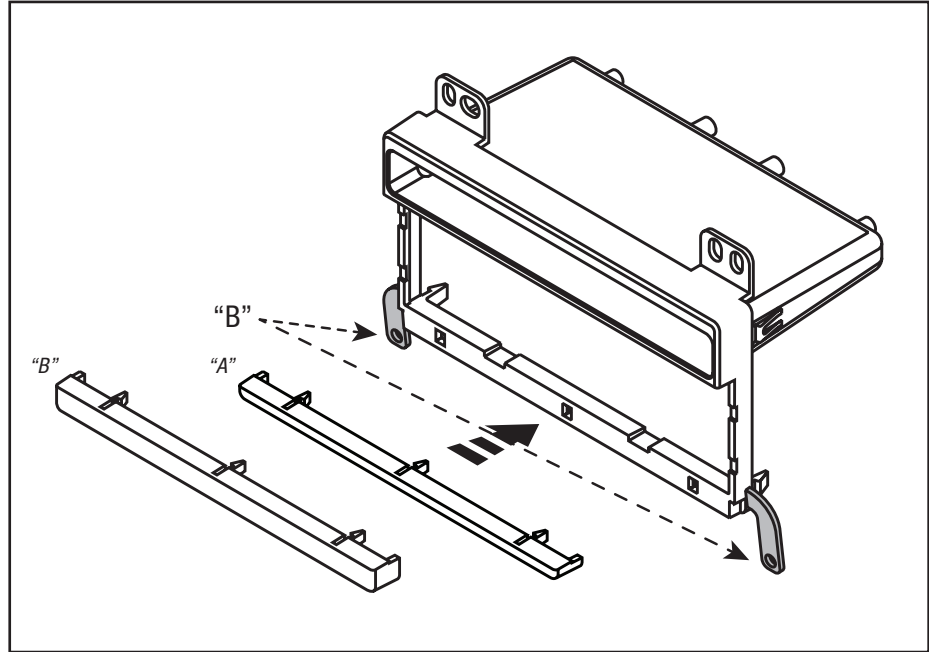

(Figura A)

Ensamble del kit

Provisión de radio DIN con cavidad

1. Quite la manga de metal DIN del radio de mercado secundario.
2. Deslice la manga en la *carcasa del radio* y sujétela doblando hacia abajo las pestañas de metal.
3. Deslice el radio en la manga hasta que haga clic.
4. Fije el soporte de montaje a la parte posterior de la *carcasa de radio* con el (2) # 8 x 3/8 " tornillos suministran. (Figura A)

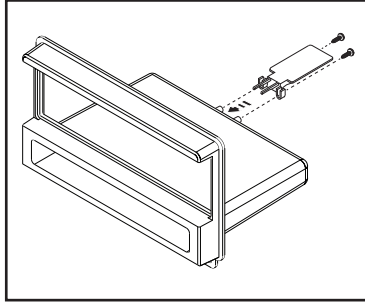

(Figura A)

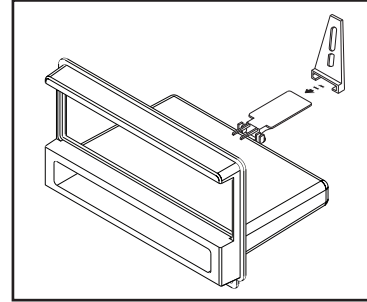

(Figura B)

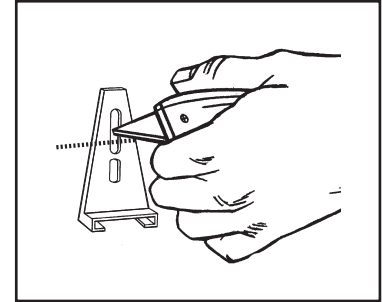

(Figura C)

5. Deslice el *soporte trasero* en el *soporte de montaje*, y luego montar el soporte a la parte posterior de la radio con el hardware incluido con la radio. (Figura B)

Nota: Para la expedición de Ford y Lincoln Navigator, cortar el soporte como se muestra en la Figura C. (Figura C)

6. Localice el arnés de cableado de fábrica y el conector de la antena en el tablero. Metra recomienda que use adaptadores adecuados de acoplamiento de Metra y/o de AXXESS. Pruebe el radio para verificar que funcione correctamente.
7. Vuelva a armar el tablero al revés de como lo desarmó.

Ensamble del kit

Provisión de radio ISO DIN con cavidad

1. Fije los *soportes ISO* a la *carcasa de la radio*, y luego asegure el uso de la (2) # 8 x 3/8 "tornillos Phillips proporcionados. (Figura A)
2. Quite la manga de metal DIN y el anillo de moldura del radio de mercado secundario.
3. Deslice el radio en la parte trasera de la abertura de la radio y luego asegure con los tornillos suministrados con la radio. (Figura B)
4. Coloque la placa para moldura en la carcasa de radio. (Figura B)
5. Localice el arnés de cableado de fábrica y el conector de la antena en el tablero. Metra recomienda que use adaptadores adecuados de acoplamiento de Metra y/o de AXCESS. Pruebe el radio para verificar que funcione correctamente.
6. Vuelva a armar el tablero al revés de como lo desarmó.

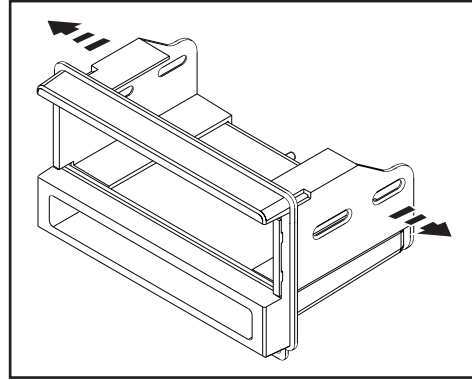

(Figura A)

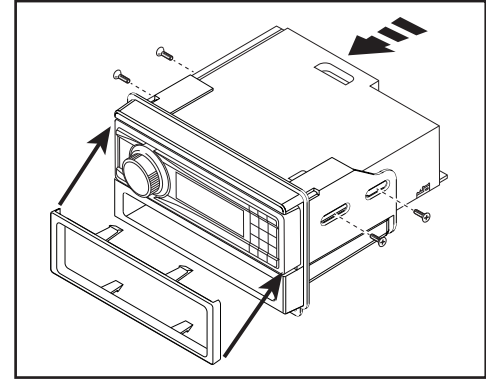

(Figura B)

Ensamble del kit

Provisión de radio DIN con cavidad

1. Quite la manga de metal DIN del radio de mercado secundario.
2. Deslice la manga en la *carcasa del radio* y sujétela doblando hacia abajo las pestañas de metal.
3. Deslice el radio en la manga hasta que haga clic.
4. Fije el soporte de montaje a la parte posterior de la *carcasa de radio* con el (2) # 8 x 3/8 "tornillos Phillips suministran. (Figura A)
5. Deslice el *soporte trasero* en el *soporte de montaje*, y luego montar el soporte a la parte posterior de la radio con el hardware incluido con la radio. (Figura B)
6. Localice el arnés de cableado de fábrica y el conector de la antena en el tablero. Metra recomienda que use adaptadores adecuados de acoplamiento de Metra y/o de AXCESS. Pruebe el radio para verificar que funcione correctamente.
7. Vuelva a armar el tablero al revés de como lo desarmó.

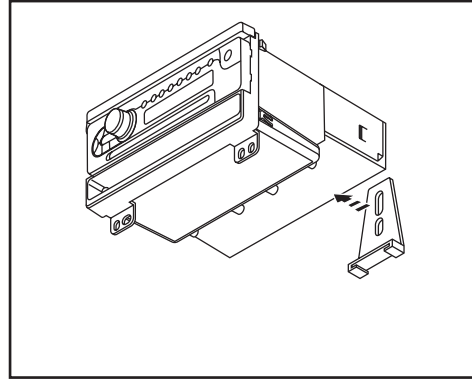

(Figura A)

Ensamble del kit

Provisión de radio ISO DIN con cavidad

1. Fije los *soportes ISO* a la *carcasa de la radio*, y luego asegure el uso de la (2) # 8 x 3/8 "tornillos Phillips proporcionados. (Figura A)
2. Quite la *manga de metal DIN* y el *anillo de moldura* del radio de mercado secundario.
3. Deslice el radio en la parte trasera de la *abertura* de la radio y luego asegure con los tornillos suministrados con la radio. (Figura B)
4. Coloque la *placa para moldura* en la *carcasa de radio*. (Figura B)
5. Localice el *arnés de cableado de fábrica* y el *conector de la antena* en el *tablero*. Metra recomienda que use *adaptadores adecuados de acoplamiento de Metra* y/o de *AXXESS*. Pruebe el radio para verificar que funcione correctamente.
6. Vuelva a armar el *tablero* al revés de como lo desarmó.

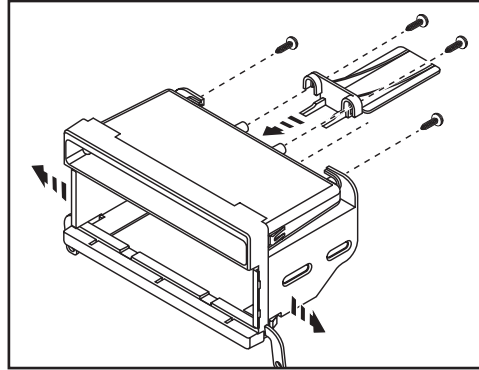

(Figura A)

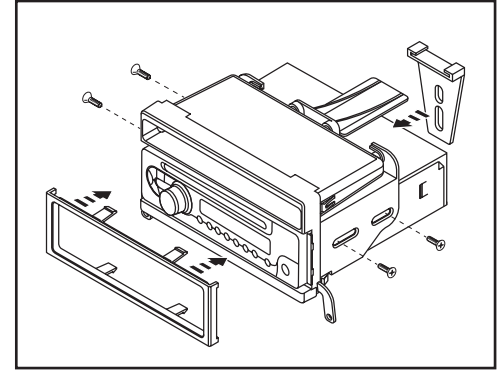

(Figura B)



99-5027

Notas



99-5027

Notas



Instrucciones de instalación para la pieza 99-5027



IMPORTANTE

Si tiene dificultades con la instalación de este producto, llame a nuestra línea de soporte técnico al **1-800-253-TECH**. Antes de hacerlo, revise las instrucciones por segunda vez y asegúrese de que la instalación se haya realizado exactamente como se indica en las instrucciones. Por favor tenga el vehículo desarmado y listo para ejecutar los pasos de resolución de problemas antes de llamar.



EL CONOCIMIENTO ES PODER

Mejore sus habilidades de instalación y fabricación inscribiéndose en la escuela de dispositivos electrónicos móviles más reconocida y respetada de nuestra industria. Regístrese en www.installerinstitute.com o llame al 800-354-6782 para obtener más información y avance hacia un futuro mejor.



Metra recomienda técnicos con certificación del Programa de Certificación en Electrónica Móvil (Mobile Electronics Certification Program, MECP).

REV. 6/13/2018 INST-99-5027