



Installation instructions for part 99-2011

GM/Suzuki multi-kit 1990-2012 99-2011/AT-555GM/CF-555GM/GMDK 1

KIT FEATURES

- ISO DIN radio provision with pocket
- ISO DDIN radio provision



KIT COMPONENTS

- A) Radio trim plate • B) Radio brackets • C) Spacers • D) (4) Carriage bolts
- E) (4) Keps nuts • F) (3) Screws with (3) speed clips • G) (4) #8 x 3/8" Phillips screws • H) Pocket

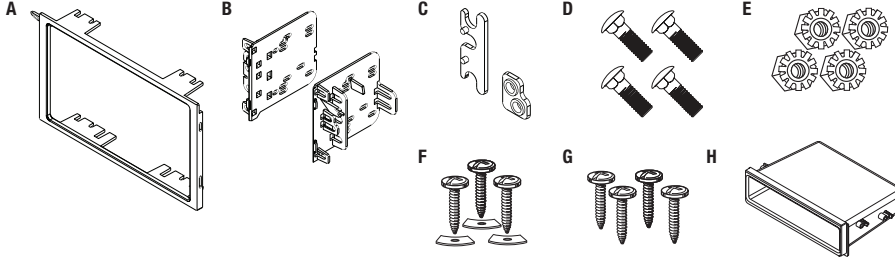

WIRING & ANTENNA CONNECTIONS (sold separately)

Wiring Harness:

- Please see www.metraonline.com for specific interface applications

Antenna Adapter:

- Please see www.metraonline.com for specific antenna adapter applications

TOOLS REQUIRED

- Cutting tool • Phillips screwdriver • Socket set

CAUTION! All accessories, switches, climate controls panels, and especially air bag indicator lights must be connected before cycling the ignition. Also, do not remove the factory radio with the key in the on position, or while the vehicle is running.

Applications

Buick	
Century.....	1997-2005
Le Sabre.....	1995-2005
Park Avenue.....	1995-2005
Rainier.....	2004-2007
Regal.....	1995-2004
Rendezvous.....	2002-2007
Riviera.....	1996-1999
Roadmaster.....	1995-1996
Skylark.....	1996-1998
Cadillac	
Escalade ESV/EXT.....	2003-2006
Fleetwood/ Brougham.....	1990-1996
Eldorado.....	1992-1995
Seville.....	1992-1995
Chevrolet (GEO)	
Avalanche.....	2003-2006
Blazer (with double DIN).....	2002-2005
Cavalier.....	2000-2005
Colorado.....	2004-2012
Express Van (full size).....	2001-2007
Impala.....	2000-2005
Kodiak.....	2003-2009
Malibu.....	2001-2003
Malibu Classic.....	2004-2005
Metro (GEO included).....	1995-2001
Monte Carlo.....	2000-2005
SSR.....	2003-2006
S-10 Pickup (with double DIN).....	2002-2004
Silverado.....	2003-2006
Chevrolet (GEO) (continued)	
Silverado Classic.....	2007
Suburban.....	2003-2006
Tahoe.....	2003-2006
Tracker (GEO included).....	1992-2004
Trailblazer.....	2002-2009
Venture.....	2000-2005
GMC	
Canyon.....	2004-2012
Envoy.....	2002-2009
Savanna.....	2001-2007
Sierra.....	2003-2006
Sierra Classic.....	2007
Sonoma (with double DIN).....	2002-2004
Top Kick.....	2005-2009
Yukon/Denali/XL.....	2003-2006
Honda	
Passport.....	1998-2002
Hummer	
H2.....	2003-2007
Isuzu	
Ascender.....	2003-2009
Amigo.....	1998-2000
H-Series.....	2003-2008
i290/i370.....	2007-2008
i280/i350.....	2006
Rodeo.....	1998-2004
Rodeo Sport.....	2001-2003
Oldsmobile	
Achieva.....	1996-1998
Alero.....	1999-2004
Aurora.....	1995-2003
Bravada.....	1998-2004
Cutlass.....	1997-1999
Cutlass Supreme.....	1995-1997
Eighty-Eight.....	1994-1999
Intrigue.....	1998-2002
LSS.....	1996-1999
Ninety-Eight.....	1994-1996
Regency.....	1997-1998
Silhouette.....	2000-2004
Pontiac	
Aztec.....	2001-2005
Bonneville.....	2000-2005
Grand Am.....	2001-2005
Montana.....	2000-2005
Sunfire.....	2000-2005
Suzuki	
Aerio.....	2002
Esteem.....	1995-2003
Sidekick.....	1992-1998
Swift.....	1995-2001
Vitara.....	1999-2004
Grand Vitara.....	1999-2002
XL-7.....	2001-2002
Toyota	
Matrix.....	2003-2004

Table of Contents

Dash Disassembly

Buick

Century 1997-2005.....	4
Le Sabre/Park Avenue 1995-1999.....	4
Le Sabre/Park Avenue 2000-2005.....	4
Rainier 2004-2007.....	16
Regal 1995-2004.....	4
Rendezvous 2002-2007.....	5
Riviera 1996-1999.....	5
Roadmaster 1995-1996.....	6
Skylark 1996-1998.....	6

Cadillac

Escalade ESV/EXT 2003-2006.....	7
Fleetwood/Brougham 1990-1996.....	7-8
Eldorado/Seville 1992-1995.....	8

Chevrolet (GEO)

Avalanche 2003-2006.....	7
Blazer (with double DIN) 2002-2005.....	8
Cavalier 2000-2005.....	9
Colorado 2004-2012.....	9
Express Van (full size) 2001-2002.....	10
Express Van (full size) 2003-2007.....	11
Impala 2000-2005.....	10
Kodiak 2003-2009.....	7



99-2011

Table of Contents

Chevrolet (GEO) (continued)

Malibu 2001-2003.....	11
Malibu Classic 2004-2005.....	11
Metro (GEO included) 1995-2001.....	12
Monte Carlo 2000-2005.....	12
SSR 2003-2006.....	13
S-10 Pickup (with double DIN) 2002-2004.....	8
Silverado 2003-2006.....	7
Silverado Classic 2007.....	7
Suburban 2003-2006.....	7
Tahoe 2003-2006.....	7
Tracker (GEO included) 1992-2004.....	12
Trailblazer 2002-2009.....	14
Venture 2000.....	14
Venture 2001-2005.....	15

GMC

Canyon 2004-2012.....	9
Envoy 2002-2009.....	16
Savanna 2001-2002.....	10
Savanna 2003-2007.....	11
Sierra 2003-2006.....	7
Sierra Classic 2007.....	7
Sonoma (with double DIN) 2002-2004.....	8
Top Kick 2005-2009.....	7
Yukon/Denali/XL 2003-2006.....	7

Honda

Passport 1998-2002.....	15
-------------------------	----

Hummer

H2 2003-2007.....	16-17
-------------------	-------

Isuzu

Ascender 2003-2009.....	16
Amigo 1998-2000.....	15
H-Series 2003-2008.....	7
i280/i350 2006.....	9
i290/i370 2007-2008.....	9
Rodeo 1998-2004.....	15
Rodeo Sport 2001-2003.....	15

Oldsmobile

Achieva 1996-1998.....	18
Alero 1999-2004.....	17
Aurora 1995-2003.....	17
Bravada 1998-2001.....	8
Bravada 2002-2004.....	16
Cutlass 1997-1999.....	18
Cutlass Supreme 1995-1997.....	18
Eighty-Eight 1994-1999.....	18
Intrigue 1998-2002.....	19
LSS 1996-1999.....	20
Ninety-Eight 1994-1996.....	18
Regency 1997-1998.....	20

Oldsmobile (continued)

Silhouette 2000.....	14
Silhouette 2001-2004.....	15

Pontiac

Aztec 2001-2005.....	20
Bonneville 2000-2005.....	20
Grand Am 2001-2005.....	19
Montana 2000 (except SV6).....	14
Montana 2001-2005 (except SV6).....	15
Sunfire 2000-2005.....	19
Vibe 2003-2008.....	21

Suzuki

Aerio 2002.....	21
Esteem 1995-2003.....	22
Grand Vitara 1999-2002.....	12
Sidekick 1992-1998.....	12
Swift 1995-2001.....	12
Vitara 1999-2004.....	12
XL-7 2001-2002.....	12

Toyota

Matrix 2003-2004.....	21
-----------------------	----

Tab Instructions

All Vehicles.....	22-23
-------------------	-------

Kit Assembly

Pre-kit Assembly, Cadillac Fleetwood/Brougham 1990-1996.....	23
All Vehicles.....	23-24

Buick Century 1997-2005/ Regal 1995-2004

1. Remove the plastic trim piece to the left of the glove box and (1) Phillips screw exposed.
2. Unsnap the top edge of the knee bolster panel.
3. Remove (1) Phillips screw from the panel.

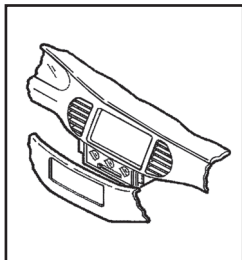

(Figure A)

4. Remove the ashtray cluster and (2) Phillips screws from each side.
5. Unclip the entire dash trim bezel and remove. (Figure A)
6. Open doors and unsnap end caps from each side of dash.
7. Unsnap and remove radio/instrument cluster panel.
8. Remove (3) screws in order to remove radio.

Continue to kit assembly

Buick Le Sabre/Park Avenue 1995-1999

1. Unsnap the climate control trim panel (from door to door) and remove (4) Phillips screws exposed. (Figure A, 1)
2. Pop out the A/C vents and remove (1) Phillips screw exposed in each vent cavity. (Figure A, 2)
3. Unclip the radio trim bezel and remove.
4. Remove the screws securing the factory radio and disconnect the wiring. (Figure A, 3)

Continue to kit assembly

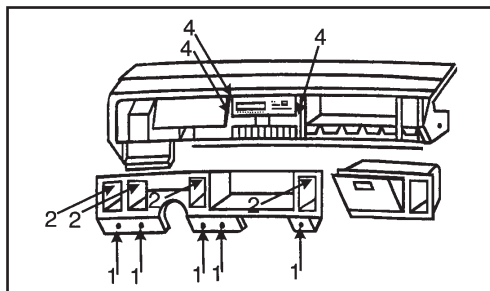

(Figure A)

Buick Le Sabre/Park Avenue 2000-2005

1. Open drivers door and unsnap and remove dash end cap.
2. Unsnap and remove trim along center of dash. (*One piece on right and one on left of wheel*)
3. Unsnap and remove radio/instrument bezel. (Figure A)
4. Remove (2) screws in order to remove radio.

Continue to kit assembly

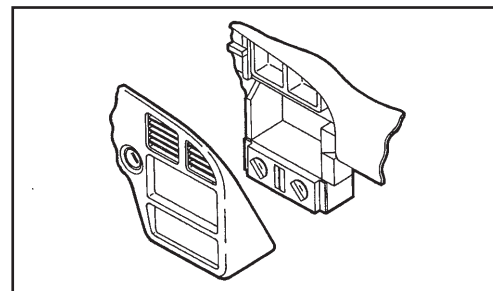

(Figure A)

Buick Rendezvous 2002-2007

1. Open center console and remove (2) screws at front of console opening. (Figure A)
2. Remove liners from cup holders and storage pocket next to cup holders, then remove screws. Unsnap and remove panel. (Figure B)
3. Remove (2) screws from bottom of radio/climate control bezel, unclip and remove. (Figure C)
4. Remove (3) 9/32" hex head screws to remove radio. (Figure D)
Continue to kit assembly

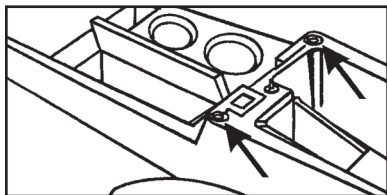

(Figure A)

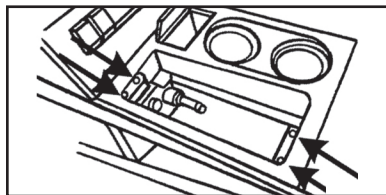

(Figure B)

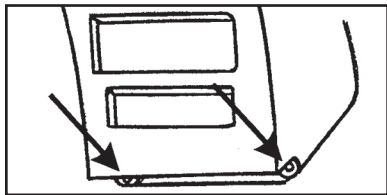

(Figure C)

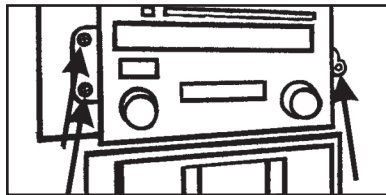

(Figure D)

Buick Riviera 1996-1999

1. Unsnap left side panel exposing (1) Phillips screw to remove. (Figure A, 1)
2. Remove (1) Phillips screw and unsnap right side panel to expose (1) Phillips screw beneath panel and remove. (Figure A, 2)
3. Unsnap underside of overhanging dash
4. Remove (5) hex head screws now exposed under overhang. (Figure A, 4)
5. Unsnap bottom edge of trim bezel, then while holding overhang up, unsnap and remove trim bezel by removing
6. Remove (3) Phillips screw to remove climate control.
7. Remove (2) Phillips screws to remove rear support and (3) 9/32" hex head screws to remove radio.
Continue to kit assembly

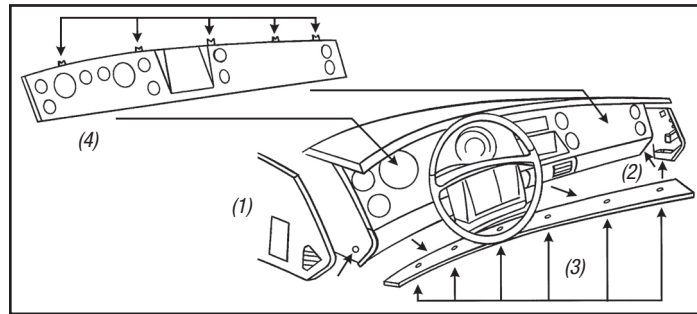

(Figure A)

Buick Roadmaster 1995-1996

1. Unclip dash panel sides and remove. (Figure A, 1)
 2. Unclip panel below steering column and remove. (Figure A, 2)
 3. Remove (2) 7mm screws above instrument cluster. (Figure A, 3)
 4. Set parking brake, turn car on, and move shifter to the lowest gear.
- Tilt steering wheel down then unsnap entire instrument cluster/radio panel and remove. (Figure A, 4)
5. Remove (3) 7mm screws to remove radio. (Figure A, 5)
- Continue to kit assembly*

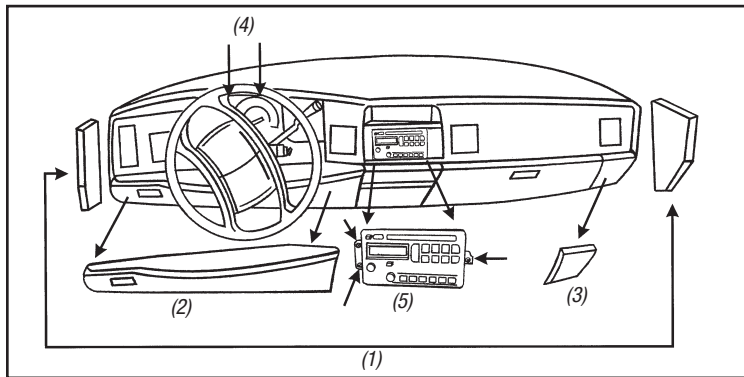

(Figure A)

Buick Skylark 1996-1998

1. Remove (6) 9/32" screws inside glove box. (Figure A, 1)
 2. Under glove box and drivers knee bolster, remove (2) plastic panels by turning (2) 1/4 turn fasteners per side.
 3. Remove (4) 9/32" screws revealed (2 per side). (Figure A, 3)
 4. Unsnap panel from driver's side to passenger's side.
 5. Remove (3) 9/32" screws to remove radio. (Figure A, 5)
- Continue to kit assembly*

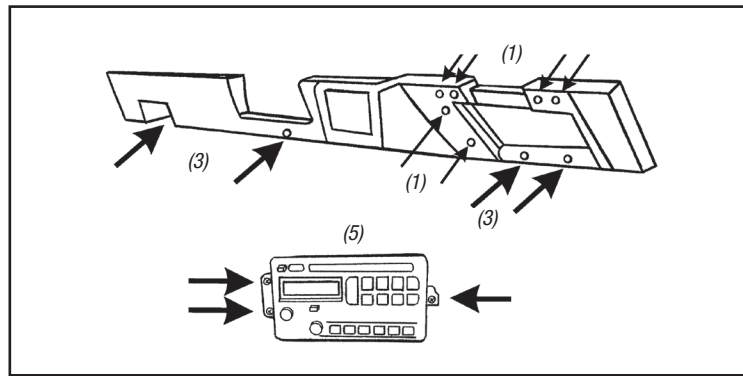

(Figure A)

Cadillac Escalade ESV/EXT 2003-2006, Chevrolet Avalanche 2003-2006/ Kodiak 2003-2009/ Silverado 2003-2006/ Silverado Classic 2007/ Suburban 2003-2006/ Tahoe 2003-2006, GMC Sierra 2003-2006/Sierra Classic 2007/Top Kick 2005-2009/Yukon/Denali/ XL 2003-2006, Isuzu H-Series 2003-2008

1. Unsnap and remove dash bezel. (Figure A)
2. Remove (3) 9/32" screws and remove radio.

Continue to kit assembly

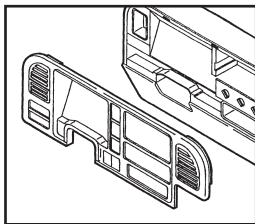

(Figure A)

Cadillac Fleetwood/Fleetwood Brougham 1990-1996

1. Carefully unsnap trim panel above A/C controls. (Figure A)
2. Remove (2) 7mm screws at the top of the radio/air conditioning bezel, then unclip panel and remove. (Figure B and C)

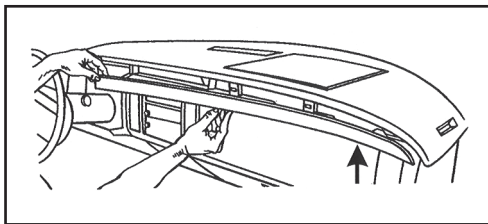

(Figure A)

3. Remove (4) 7mm screws that hold the radio in, slide radio out, unplug the radio harnesses and remove radio. (Figure D)

Continue to radio bracket disassembly (next page)

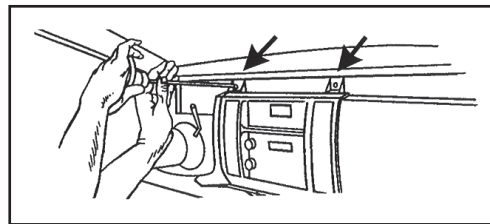

(Figure B)

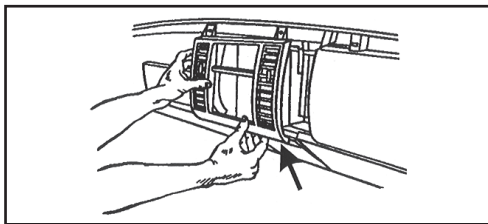

(Figure C)

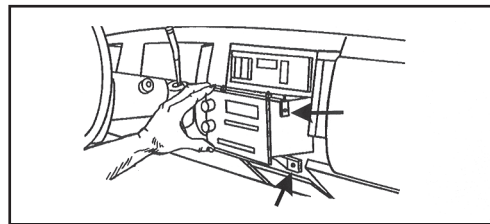

(Figure D)

Cadillac Fleetwood/ Fleetwood Brougham 1990-1996

Radio bracket disassembly

1. Remove (4) 10mm nuts, (2) on top of the radio and (2) on the bottom of the radio, that hold the factory mounting brackets on. Save brackets and nuts for kit assembly.

Continue to kit assembly

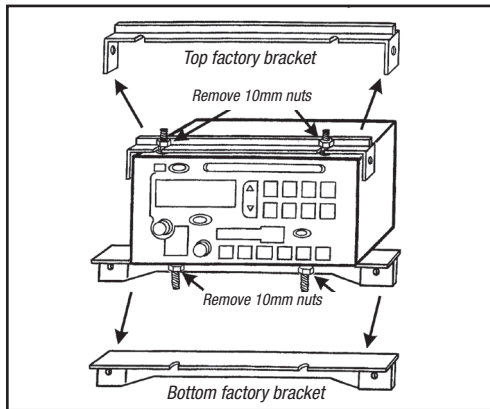

(Figure A)

Cadillac Eldorado/Seville 1992-1995

1. Using a panel removal tool, pry out on the radio trim ring and remove. Use extreme care when removing. (Figure A)
2. Gently pry up on the ashtray/gear shifter trim bezel and remove.

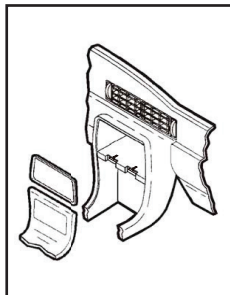

Caution: Some models are equipped with bezels made of real wood. (Figure A)

3. Remove (2) nuts securing the bottom of the factory radio and disconnect the wiring.

Continue to kit assembly

Chevrolet Blazer 2002-2005 (with double DIN)/S-10 2002-2004 (with double DIN), GMC Sonoma 2002-2004 (with double DIN), Oldsmobile Bravada 1998-2001

1. Remove (2) 9/32" hex-head screws from the knee bolster panel.
2. Pull down on the panel and remove the 9/32" hex-head screw(s) exposed on the bottom of the dash trim bezel. (Figure A)
3. Remove (1) Phillips screw above the instrument cluster. (Figure A)
4. Unclip the dash trim bezel and remove. (Figure A)
5. Remove (2) 9/32" hex-head screws securing the factory radio and disconnect the wiring.

Continue to kit assembly

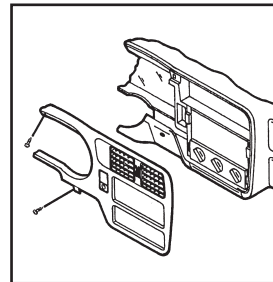

(Figure A)

**Chevrolet Colorado/GMC
Canyon 2004-2012, Isuzu
i280/i350 2006, Isuzu
i290/i370 2007-2008**

1. Unsnap and remove the entire panel surrounding the radio and A/C controls. (Figure A)
2. Remove (3) 9/32" screws securing the radio to remove. (Figure B)

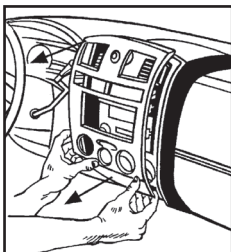

(Figure A)

Continue to kit assembly

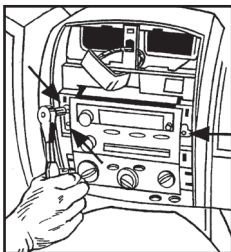

(Figure B)

Chevrolet Cavalier 2000-2005

1. Open drivers door and remove fuse panel on end of dash.
2. Open passenger door and remove panel on end of dash.
3. Remove (1) Phillips screw from each side exposed.
4. Remove (3) screws from top of glove box liner.
5. Remove (2) screws from the top-left corner of the glove box cavity.
6. Remove (1) Phillips screw from the defroster duct.
7. Remove the duct work and (1) Phillips screw exposed.
8. Remove the dash pad and (3) Phillips screws exposed at the top of the radio trim bezel. *Continue to kit assembly*

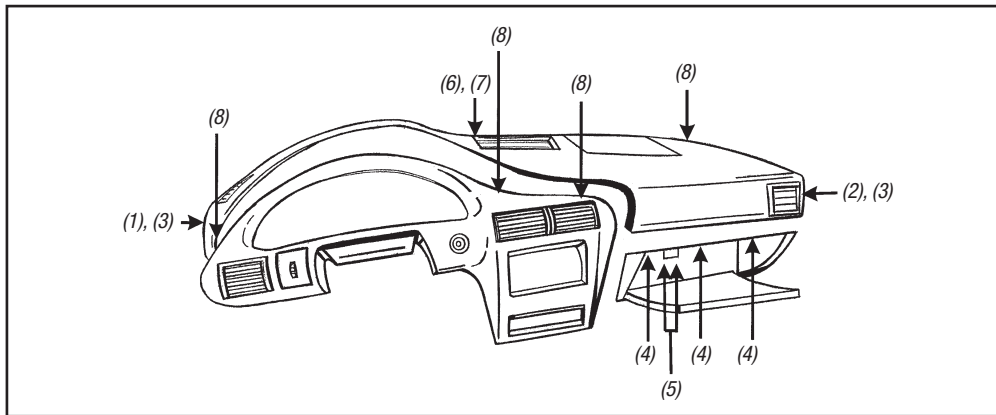

Chevrolet Express Van (full size)/GMC Savanna 2001-2002

1. Unsnap and remove small trim panel below steering column. (Figure A)
2. Unsnap radio/climate/instrument panel. (Figure B)
3. Move shift lever to first gear position.
4. Rotate panel counterclockwise to lift over steering column and remove.
5. Remove (3) 9/32" hex head screws to remove radio. (Figure C)

Continue to kit assembly

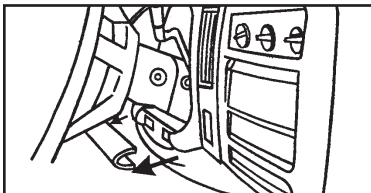

(Figure A)

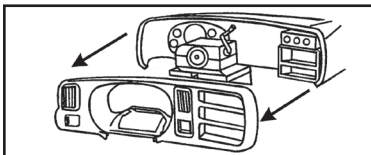

(Figure B)

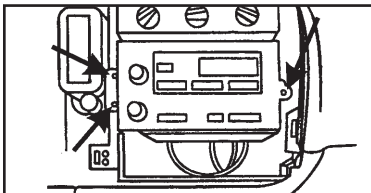

(Figure C)

Chevrolet Impala 2000-2005

1. Unclip each side of the dash trim bezel (fuse access) and remove (1) Phillips screw exposed on each side.
 2. Remove (2) Phillips screws under the instrument cluster.
 3. Unclip the trim panel above the pedals. (It is not necessary to remove the panel it can be left hanging).
 4. Remove (2) Phillips screws from the knee panel.
 5. Unclip the knee panel and remove (1) Phillips screw exposed on the right side of the steering column.
 6. Unclip and remove the entire dash trim bezel. (Figure A)
- Continue to kit assembly*

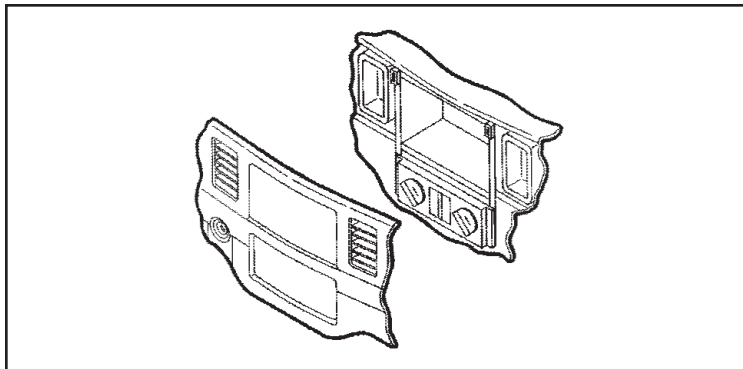

(Figure A)

Chevrolet Express Van (full size)/GMC Savanna 2003-2007

1. Remove (2) 10mm bolts from below knee bolster under steering column and remove panel. (Figure A)
2. Remove (2) 10mm bolts from panel below passenger dash airbag and remove panel. (Figure B)
3. Remove (2) 10mm nuts from inside center pocket between power outlets. (Figure C)
4. Unsnap and remove radio and instrument cluster panel. *(May not be necessary to completely*

remove radio and instrument cluster panel to access radio.)

5. Remove (3) 9/32" bolts to remove radio. (Figure D)

Continue to kit assembly

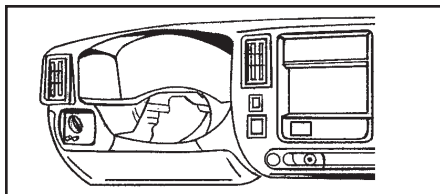

(Figure A)

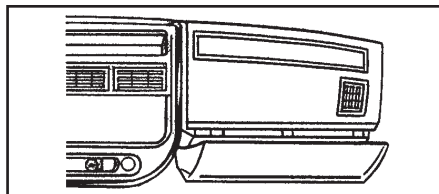

(Figure B)

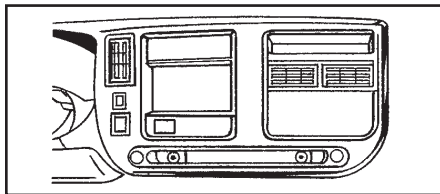

(Figure C)

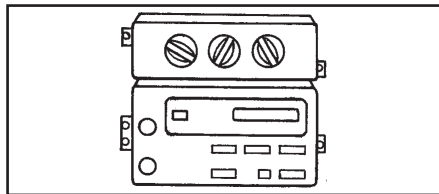

(Figure D)

Chevrolet Malibu 2001-2003/ Malibu Classic 2004-2005

1. Unsnap and remove radio bezel. (Figure A, 1)
2. Remove (3) bolts and remove radio. (Figure A, 2)

Continue to kit assembly

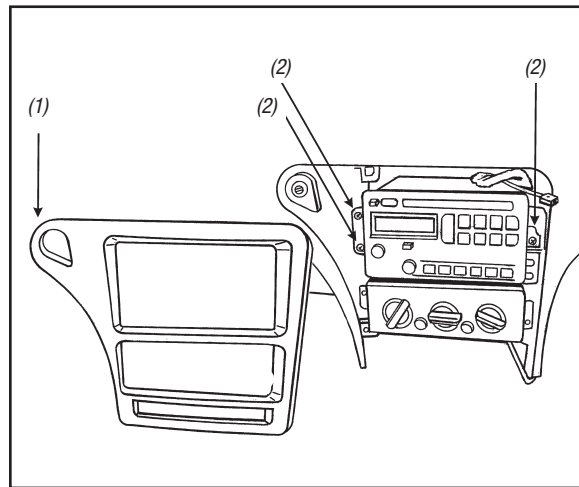

(Figure A)

Chevrolet Metro (GEO included) Suzuki Swift 1995-2001

1. Remove the ashtray and (2) Phillips screws exposed. (Figure A)
2. Remove (2) Phillips screws above the radio opening. (Figure A)
3. Unclip the radio trim bezel and disconnect the cigarette lighter wiring.
4. Remove (2) screws securing each side of the factory radio and (1) screw from the rear support.
5. Slide the radio out and disconnect the wiring.

Continue to kit assembly

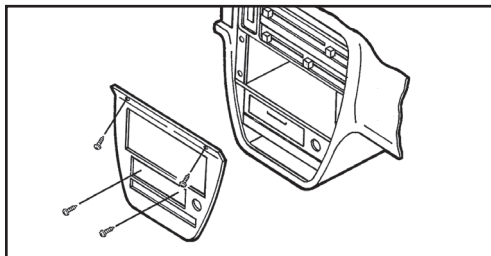

(Figure A)

Chevrolet Monte Carlo 2000-2005

1. Unclip the trim panel above the pedals. (*It is NOT necessary to remove the panel it may be left hanging.*) (Figure A)
2. Remove (2) 9/32" screws from the knee panel and unclip the panel.
3. Unsnap the driver's side fuse panel cover and remove (1) 9/32" screw.
4. Open the glove box and remove (1) 9/32" screw from the upper left corner.
5. Remove (3) 9/32" screws securing the factory radio and disconnect the wiring.

Continue to kit assembly

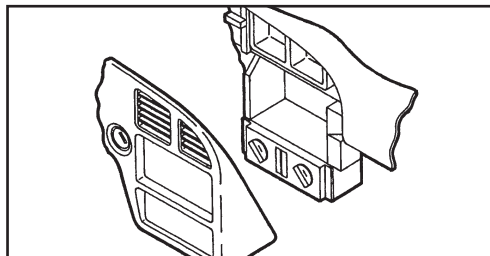

(Figure A)

Chevrolet Tracker (GEO included) 1992-2004, Suzuki Sidekick 1992-1998/Vitara 1999-2004/Grand Vitara 1999-2002/XI-7 2001-2002

1. Remove the cigarette lighter and climate control knobs.
2. Remove the ashtray and (1) screw exposed.
3. Pull out on the climate control cluster and remove (2) screws exposed.
4. Unclip the radio trim bezel. (Figure A)
5. Remove (4) screws from the factory radio, slide the radio out and disconnect the wiring.)

Continue to kit assembly

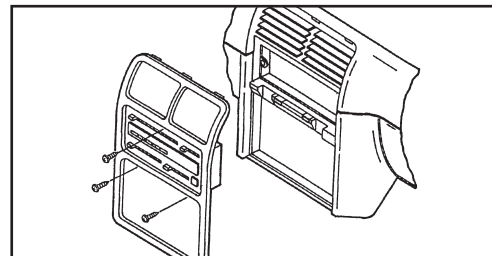

(Figure A)

Chevrolet SSR 2003-2006

1. Unclip and remove the (3) climate control knobs. (Figure A)
2. Unclip and remove the long trim panel below the radio and passenger air bag. (Figure B)
3. Unclip and remove the small trim panel to the left of the steering wheel. (Figure C)
4. Remove the (5) 9/32" screws securing the radio/instrument panel then unclip and remove the panel. (Figure D)
5. Remove the screws securing the factory radio and disconnect the wiring.
Continue to kit assembly

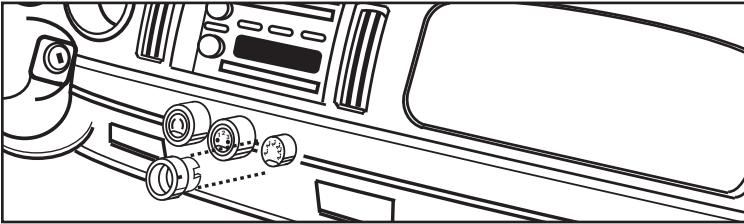
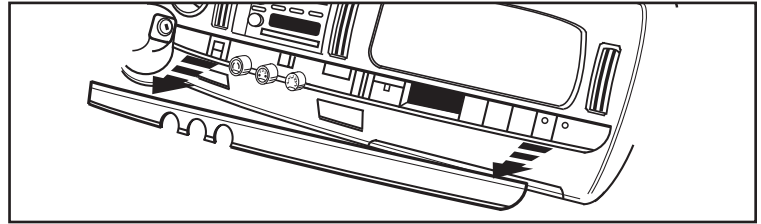
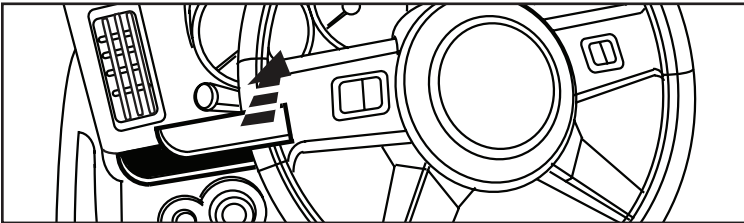
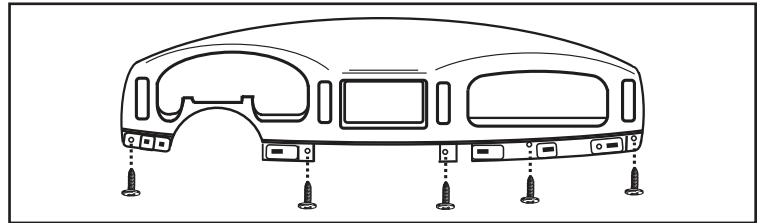
*(Figure A)**(Figure B)**(Figure C)**(Figure D)*

Chevrolet Trailblazer 2002-2009

1. Remove (2) Phillips screws inside instrument cluster. (Figure A, 1)
2. Remove (1) Phillips screw under climate controls to the left of the power outlet. (Figure A, 2)
3. Remove (2) 7mm hex heads from under steering column and lower the panel. Remove (3) Phillips screws around steering wheel. (Figure A, 3)
4. Unsnap and remove bezel. *(Use caution pulling over hazard switch.)* Remove (3) 7mm hex head screws to remove radio.
Continue to kit assembly

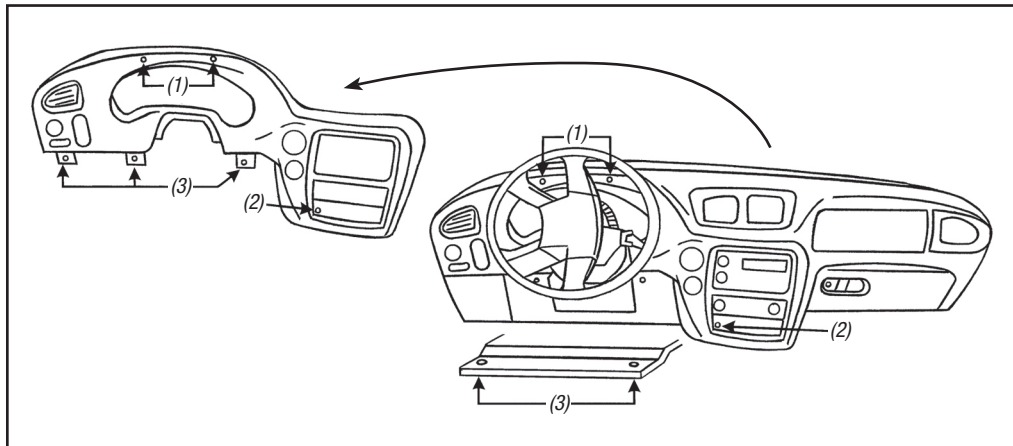

(Figure A)

Chevrolet Venture/ Oldsmobile Silhouette 2000, Pontiac Montana 2000 *(except SV6)*

1. Remove the ashtray and (1) Phillips screw exposed in the ashtray cavity.
2. Remove (1) Phillips screw from the cigarette lighter compartment.
3. Remove (2) Phillips screws securing the factory radio and disconnect the wiring.

Continue to kit assembly

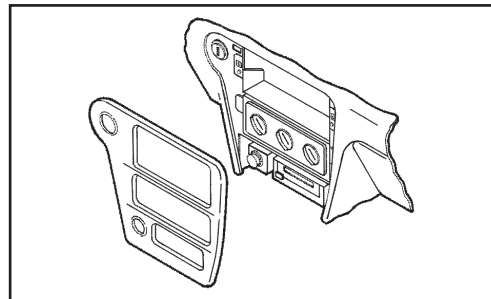

Chevrolet Venture 2001-2005, Oldsmobile Silhouette 2001-2004, Pontiac Montana 2001-2005 (except SV6)

1. Remove the ashtray and (1) Phillips screw exposed in the ashtray cavity. (Figure A)
2. Remove (1) Phillips screw from the cigarette lighter compartment. (Figure B and C)
3. Remove (2) Phillips screws securing the factory radio and disconnect the wiring. (Figure D)

Continue to kit assembly

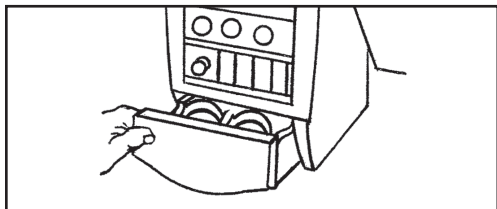

(Figure A)

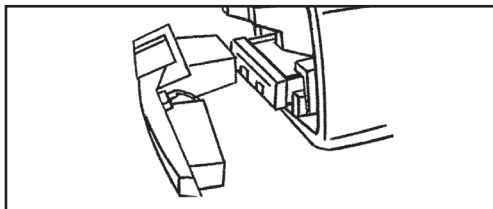

(Figure B)

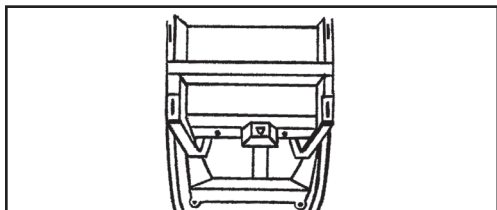

(Figure C)

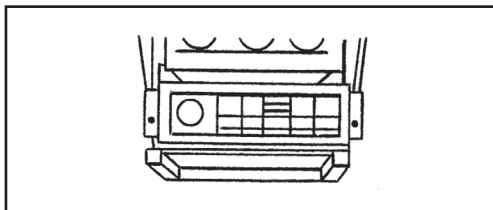

(Figure D)

Honda Passport 1998-2002, Isuzu Amigo 1998-2000/Rodeo 1998-2004/Rodeo Sport 2001-2003

1. Remove the ashtray and (1) Phillips screw exposed in the ashtray cavity. Unclip and remove the trim panel surrounding the factory radio. (Figure A)
2. Remove (4) Phillips screws securing the factory radio and disconnect the wiring.

Continue to kit assembly

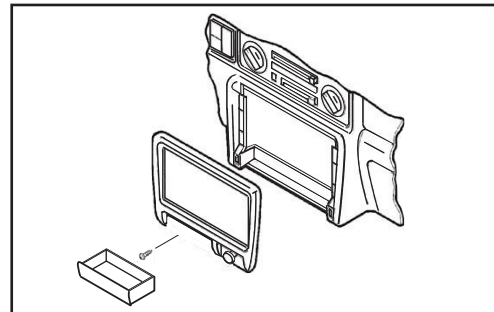

(Figure A)

GMC Envoy 2002-2009, Isuzu Ascender 2003-2009, Oldsmobile Bravada 2002-2004, Buick Ranier 2004-2007

1. Remove (4) Phillips screws, (2) from left and (2) from right of carpeted panel. (Figure A)
2. Slide carpeted panel down and backwards to reveal (2) Phillips screws and remove. (Figure B)
3. Unsnap radio bezel and unplug cigarette lighter and accessories. (Figure C)
4. Remove (3) screws and remove radio. (Figure C)

Continue to kit assembly

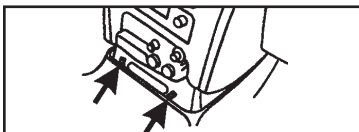

(Figure B)

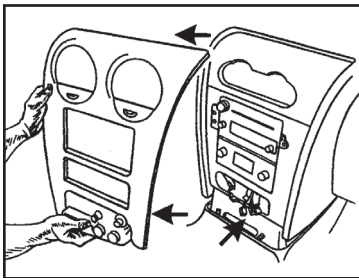

(Figure C)

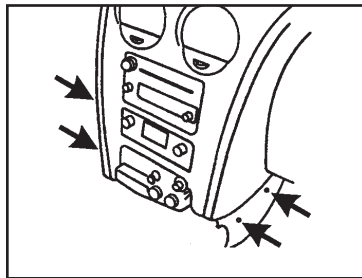

(Figure A)

Hummer H2 2003-2007

1. Open center console and remove (4) 9/32" screws from console box and remove box. (Figure A)
2. Remove (4) Phillips screws from hinge on console door inside console and remove door. (Figure B)
3. Loosen (1) T-15 torx on forward facing side of shift lever and pull up to remove. (Figure C)
4. Unclip cup holder/shifter trim assembly and remove. (Figure D)
5. Remove (6) Phillips screws from top of center console.
6. Remove (2) Phillips screws from inside pocket on back of center

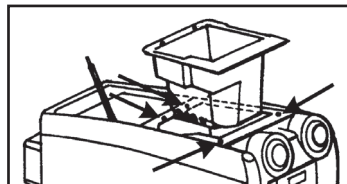

(Figure A)

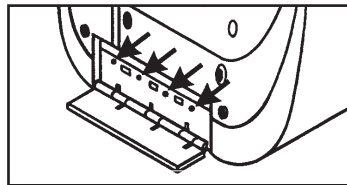

(Figure B)

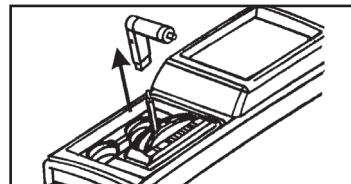

(Figure C)

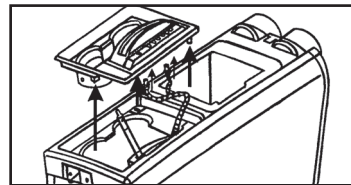

(Figure D)

Hummer H2 2003-2007

- console, then unclip and remove.
- Remove (1) 10mm bolt to right of shift lever. (Figure E)
 - Remove (2) Phillips screws from under console box on drivers side and (2) Phillips screws from under console trimtop on passenger side. (Figure E)

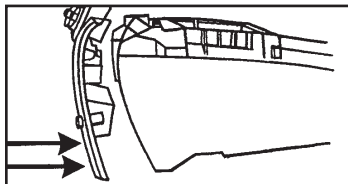

(Figure E)

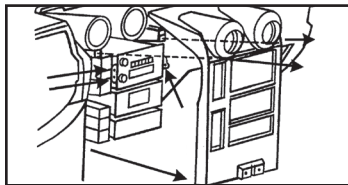

(Figure G)

- Slide control assembly rearwards. (Figure F)
- Remove (2) T-30 torx bolts from top of rado/climate control trim and unclip and remove. (Figure G)
- Remove (3) 9/32" screws that hold the radio in. (Figure G)

Continue to kit assembly

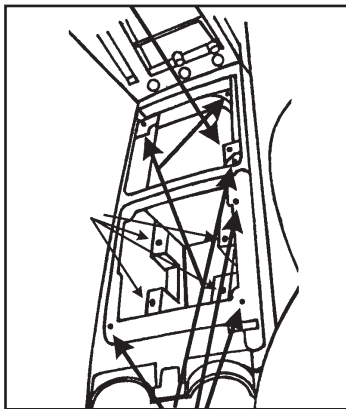

(Figure F)

Oldsmobile Alero 1999-2004

- Remove shift knob by using a small screwdriver to remove U-clip from front of shifter and pull upward.
- Unclip and remove shifter trim panel.
- Unclip and remove radio and climate control panel by pulling from bottom. (Figure A)
- Remove (3) 9/32" screws from radio and remove.

Continue to kit assembly

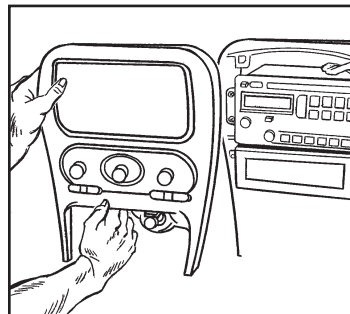

(Figure A)

Oldsmobile Aurora 1995-2003

- Unclip the radio trim bezel and remove the bezel. (Figure A)
- Remove (2) 7mm screws securing the factory radio and disconnect the wiring.

Continue to kit assembly

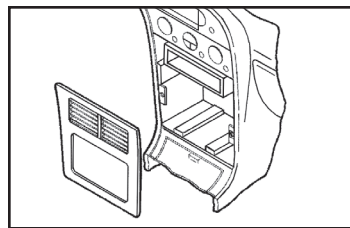

(Figure A)

Oldsmobile Achieva 1996-1998

1. Open the glove box, press inward on the walls of the glove box liner and remove the liner.
2. Remove (10) torx-head screws from the glove box location.
3. Remove (2) 9/32" hex-head screws under the steering column.
4. Unclip the dash trim bezel. (Figure A)
5. Remove the screws securing the factory radio and disconnect the wiring.

Continue to kit assembly

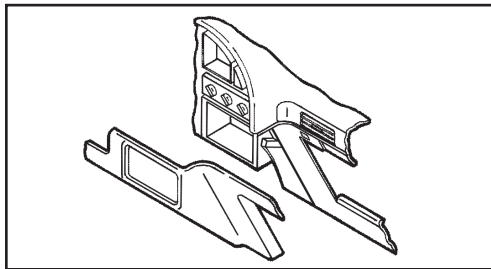

(Figure A)

Oldsmobile Cutlass 1997- 1999/Cutlass Supreme 1995-1997

1. Unclip the radio trim bezel and remove. (Figure A)
2. Remove (2) 9/32" hex-head screws securing the factory radio and disconnect the wiring.

Continue to kit assembly

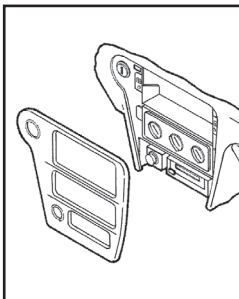

(Figure A)

Oldsmobile Eighty-Eight 1994-1999

1. Unclip the radio trim bezel and remove.
2. Remove (2) 9/32" hex-head screws securing the factory radio and disconnect the wiring.

Continue to kit assembly

Oldsmobile Ninety-Eight 1994-1996

1. Open the glove box and remove (2) hex-head screws securing the wood trim.
2. Unsnap the wood trim and remove.
3. Remove (2) hex-head screws below the radio trim bezel.
4. Lift up on the bezel and remove.
5. Remove (3) Phillips hex-head screws securing the factory radio and disconnect the wiring.

Continue to kit assembly

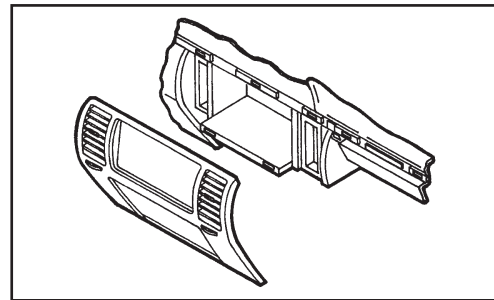

(Figure A)

Oldsmobile Intrigue 1998-2002

1. Open the center console storage compartment and remove (2) 9/32" hex-head screws exposed.
2. Remove the center console.
3. Unclip the radio trim bezel and remove.
4. Remove (2) 9/32" hex-head screws securing the factory radio and disconnect the wiring.

Continue to kit assembly

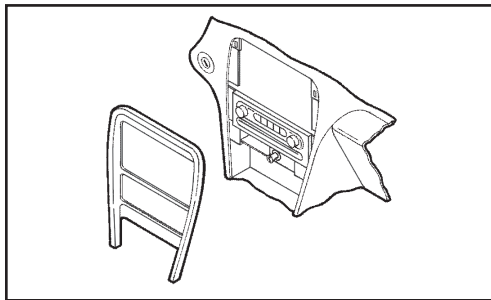

(Figure A)

Pontiac Grand Am 2001-2005

1. Unsnap and remove radio trim bezel. (Figure A, 1)
2. Remove (3) 9/32" screws from radio brackets and remove radio. (Figure A, 2)

Continue to kit assembly

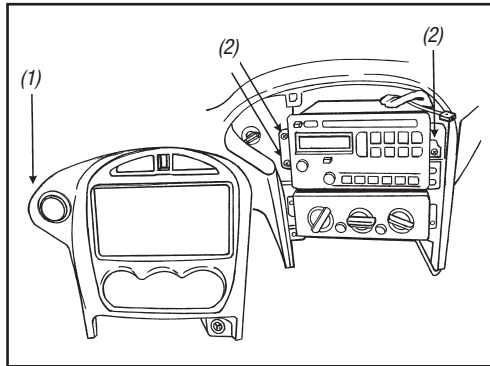

(Figure A)

Pontiac Sunfire 2000-2005

1. Open the glove box and remove (2) Phillips screws exposed on the right edge of the radio trim bezel.
2. Unclip the bezel and remove.
3. Remove (2) 7mm hex-head screws securing the factory radio and disconnect the wiring.

Continue to kit assembly

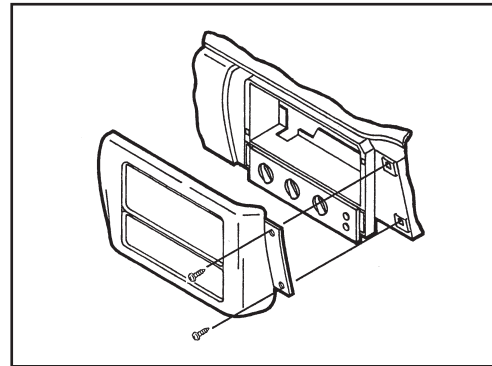

(Figure A)

Oldsmobile L55 1996-1999/ Regency 1997-1998

1. Open glove box and remove two-center trim bezels attached by screws. (Figure A, 1)
2. Unsnap and remove radio trim bezel. (Figure A, 2)
3. Remove (3) 9/32" hex-head screws and remove radio. (Figure A, 3)
Continue to kit assembly

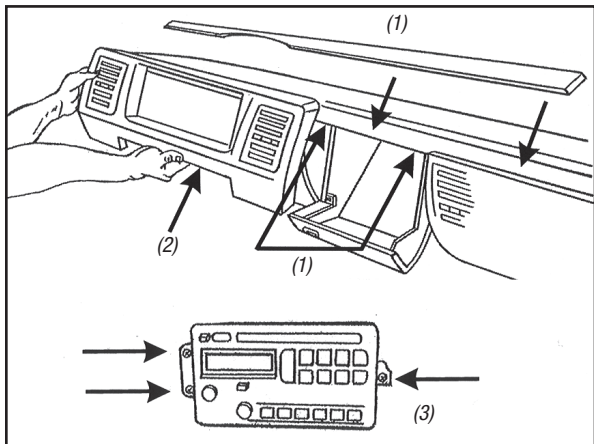

(Figure A)

Pontiac Aztec 2001-2005

1. Pull out cup holder inserts.
2. Remove (1) Phillips screw exposed inside bottom cup holder.
3. Unsnap and remove shifter trim with cup holders.
4. Remove (2) #15 torx at bottom of radio/climate bezel.
Continue to kit assembly

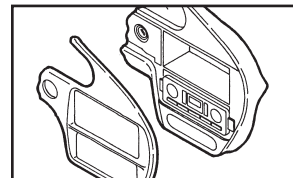

(Figure A)

Pontiac Bonneville 2000-2005

1. Remove (2) Phillips screws from the instrument cluster. (Figure A)
2. Unclip the ignition trim and remove. (Figure B)
3. Unclip the climate control/radio trim bezel and remove.
4. Depress the spring clips on each side of the factory radio and remove. (Figure C)

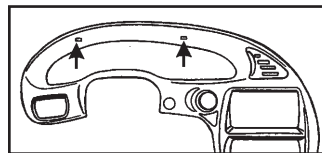

(Figure A)

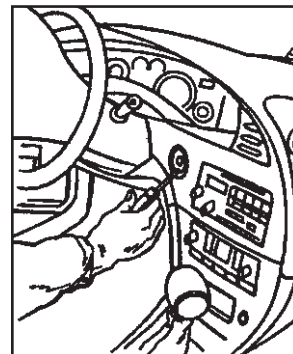

(Figure B)

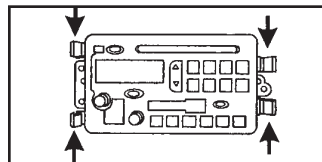

(Figure C)

*Continue to
kit assembly*

**Pontiac Vibe 2003-2008,
Toyota Matrix 2003-2004**

1. Unclip the bottom edge of the radio trim panel then lift up and out to remove. (Figure A)
2. Remove (4) 10mm bolts securing the factory radio. (Figure B)

*Continue to
kit assembly*

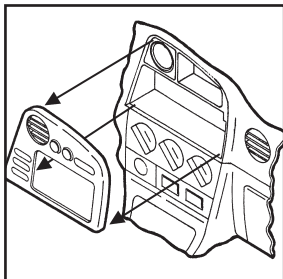

(Figure A)

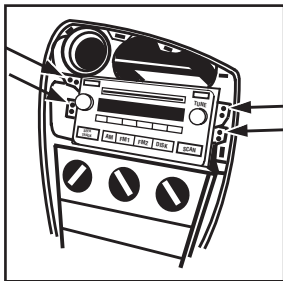

(Figure B)

Suzuki Aerio 2002

1. Unclip the dash trim bezel and remove. (Figure A)
2. Remove (4) Phillips screws securing the factory radio and disconnect the wiring.

Continue to kit assembly

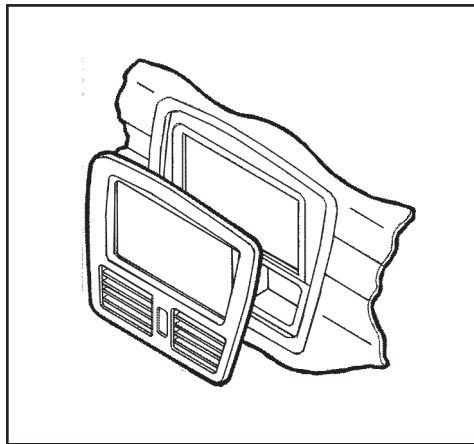

(Figure A)

Suzuki Esteem 1995-2003

1. Remove the climate control knobs.
2. Remove (1) Phillips screw located above the radio opening. (Figure A)
3. Unclip the radio trim bezel. (Figure A)
4. Remove (4) screws from the factory radio, slide the radio out and disconnect the wiring.

Continue to kit assembly

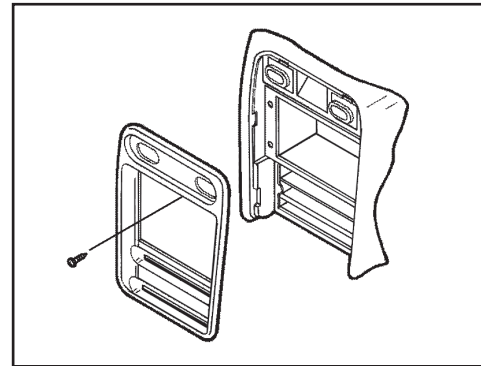

(Figure A)

All Vehicles

1. GM vehicles

Break off all tabs on the radio brackets as shown. (Figure A)

2. Chevy Metro/Tracker, and Suzuki vehicles

Break off all tabs on the radio brackets as shown. (Figure B)

3. Cadillac Fleetwood/Brougham

Break off all tabs on the radio brackets as shown. (Figure C)

4. Isuzu Amigo/Rodeo/Rodeo Sport

Break off all tabs on the radio brackets as shown. (Figure D)

5. Toyota Matrix/Pontiac Vibe

Break off all tabs on the radio brackets as shown. (Figure E1)

Cut (4) tabs on the radio trim plate as shown. (Figure E2)

6. Cadillac Eldorado/Seville

Break off all tabs on the radio brackets as shown. (Figure F1)
Cut (1) tab on the radio trim plate as shown. (Figure F2)

Continue to Kit Assembly

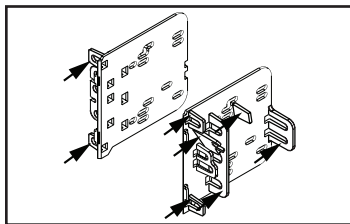

(Figure A)

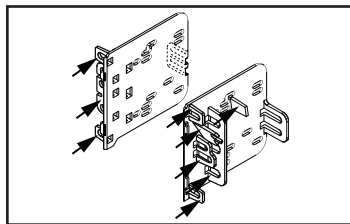

(Figure C)

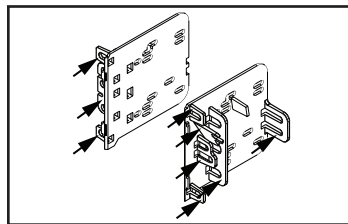

(Figure E1)

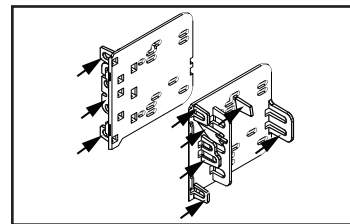

(Figure F1)

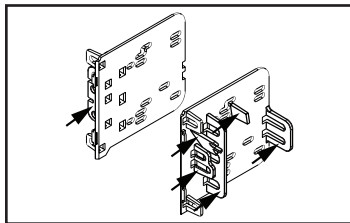

(Figure B)

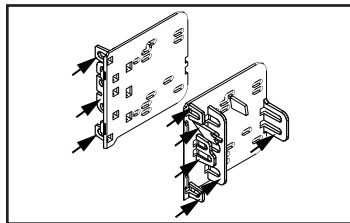

(Figure D)

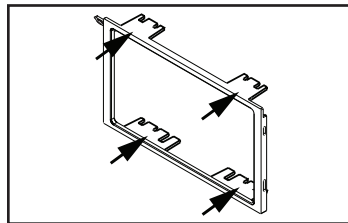

(Figure E2)

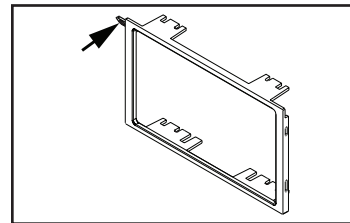

(Figure F2)

Pre-kit Assembly for Cadillac Fleetwood/Brougham 1990-1996

- Using carriage bolts and Keps nuts supplied, mount the factory brackets to the radio-trim-plate/radio-bracket assembly (keeping in mind which bracket is top and which one is bottom).

Continue to Kit Assembly "All vehicles"

***Note:** Figure A shows the radio installed for illustrative purposes only.

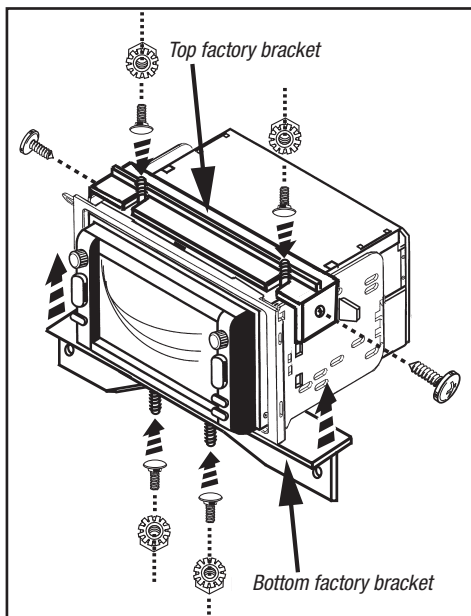

*(Figure A)

All vehicles

For both applications:

1. Insert the radio brackets to the edge of the radio trim plate. (Figure A)

For ISO DIN radio provision with pocket:

2. Secure the pocket to the radio brackets with (4) #8 X 3/8" Phillips screws supplied.
3. Remove the metal DIN sleeve and trim ring from the aftermarket radio.
4. Insert the radio through the rear of the completed pocket assembly, and then secure using screws supplied with the radio. (Figure B1)

Continue to "All applications"

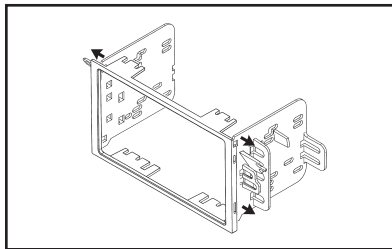

(Figure A, for both provisions)

For ISO DDIN radio provision:

2. Insert the radio into the completed assembly through the rear, and secure using screws supplied with the radio. (Figure B2) Continue to "All applications"

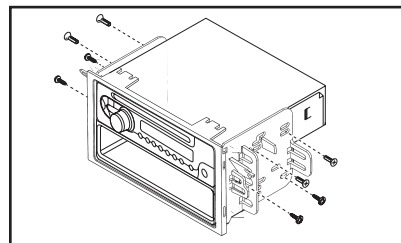

(Figure B1)

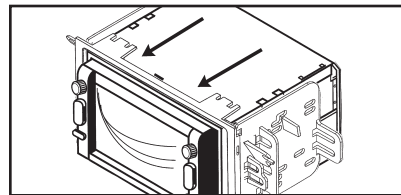

(Figure B2)



All vehicles (continued)

All applications:

1. Locate the factory wiring harness and antenna connector in the dash. Metra recommends using the proper mating adapter from Metra or AXCESS. Test the radio for proper operation.
2. Secure the completed assembly into the dash and reassemble the dash in reverse order of disassembly.

Note: For the Cadillac Eldorado/Seville 1992-1995.

(1) Align the tabs on the bottom of the radio trim plate/radio bracket assembly with notches in the sub-dash. (Figure C)

(2) Secure with the (2) carriage bolts and (2) Keps nuts provided. (Figure C)

Note: For the Buick Le Sabre, Oldsmobile Aurora, and the Pontiac Bonneville.

(1) The (3) speed clips and screws provided with the kit will need to be installed into the sub-dash where the screw holes line up on the kit.

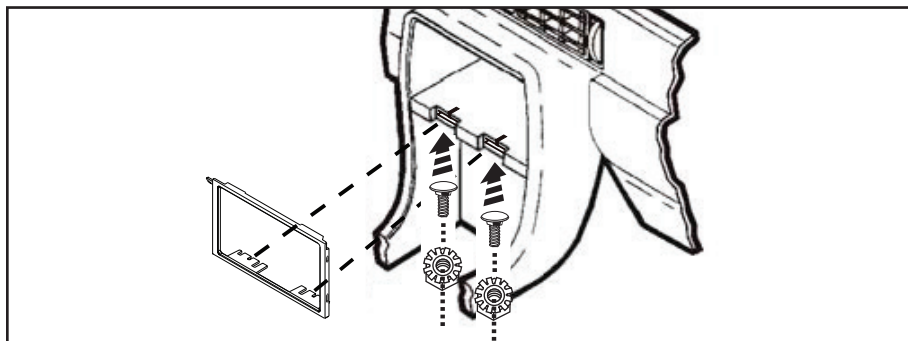

(Figure C)

IMPORTANT

If you are having difficulties with the installation of this product, please call our Tech Support line at **1-800-253-TECH**. Before doing so, look over the instructions a second time, and make sure the installation was performed exactly as the instructions are stated. Please have the vehicle apart and ready to perform troubleshooting steps before calling.



KNOWLEDGE IS POWER

Enhance your installation and fabrication skills by enrolling in the most recognized and respected mobile electronics school in our industry. Log onto www.installerinstitute.com or call 800-354-6782 for more information and take steps toward a better tomorrow.



Metra recommends MECP certified technicians



Instrucciones de instalación para la pieza 99-2011

GM/Suzuki multi-kit 1990-2012 99-2011/AT-555GM/CF-555GM/GMDK 1

CARACTERÍSTICAS DEL KIT

- Provisión de radio ISO DIN con bolsillo
- Provisión de radio ISO DDIN



COMPONENTES DEL KIT

- A) Placa de moldura de radio • B) Soportes radio • C) Espaciadores • D) (4) Perno de carro • E) (4) Tuercas keps • F) (3) Tornillos con (3) ganchos de velocidad • G) (4) Tornillos Phillips #8 x 3/8" • H) Bolsillo

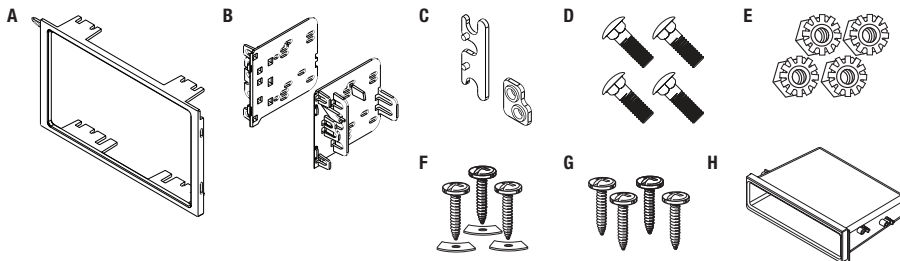

APLICACIONES

Ver interior de la portada

CABLEADO Y CONEXIONES DE ANTENA

Arnés de cableado: (se venden por separado)

- Visite www.metraonline.com para ver aplicaciones específicas de interfase

Adaptador de antena:

- Por favor, vea www.metraonline.com para aplicaciones específicas adaptador de antena

HERRAMIENTAS REQUERIDAS

- Herramienta de corte • Destornillador Phillips
- Toma de conjunto

¡PRECAUCIÓN! Todos los accesorios, interruptores, paneles de controles de clima y especialmente las luces del indicador de las bolsas de aire deben estar conectados antes ciclar la ignición. Además, no quite el radio de fábrica con la llave en la posición o de encendido ni con el vehículo funcionando.

Aplicaciones

Buick	
Century.....	1997-2005
Le Sabre.....	1995-2005
Park Avenue.....	1995-2005
Rainier.....	2004-2007
Regal.....	1995-2004
Rendezvous.....	2002-2007
Riviera.....	1996-1999
Roadmaster.....	1995-1996
Skylark.....	1996-1998
Cadillac	
Escalade ESV/EXT.....	2003-2006
Fleetwood/ Brougham.....	1990-1996
Eldorado.....	1992-1995
Seville.....	1992-1995
Chevrolet (GEO)	
Avalanche.....	2003-2006
Blazer (con doble DIN).....	2002-2005
Cavalier.....	2000-2005
Colorado.....	2004-2012
Express Van (tamaño completo).....	2001-2007
Impala.....	2000-2005
Kodiak.....	2003-2009
Malibu.....	2001-2003
Malibu Classic.....	2004-2005
Metro (GEO incluido).....	1995-2001
Monte Carlo.....	2000-2005
SSR.....	2003-2006
S-10 Pickup (con doble DIN).....	2002-2004
Silverado.....	2003-2006
Chevrolet (GEO) (seguido)	
Silverado Classic.....	2007
Suburban.....	2003-2006
Tahoe.....	2003-2006
Tracker (GEO incluido).....	1992-2004
Trailblazer.....	2002-2009
Venture.....	2000-2005
GMC	
Canyon.....	2004-2012
Envoy.....	2002-2009
Savanna.....	2001-2007
Sierra.....	2003-2006
Sierra Classic.....	2007
Sonoma (con doble DIN).....	2002-2004
Top Kick.....	2005-2009
Yukon/Denali/XL.....	2003-2006
Honda	
Passport.....	1998-2002
Hummer	
H2.....	2003-2007
Isuzu	
Ascender.....	2003-2009
Amigo.....	1998-2000
H-Series.....	2003-2008
i290/i370.....	2007-2008
i280/i350.....	2006
Rodeo.....	1998-2004
Rodeo Sport.....	2001-2003

Indice

Desmontaje del tablero

Buick

Century 1997-2005.....	4
Le Sabre/Park Avenue 1995-1999.....	4
Le Sabre/Park Avenue 2000-2005.....	4
Rainier 2004-2007.....	16
Regal 1995-2004.....	4
Rendezvous 2002-2007.....	5
Riviera 1996-1999.....	5
Roadmaster 1995-1996.....	6
Skylark 1996-1998.....	6

Cadillac

Escalade ESV/EXT 2003-2006.....	7
Fleetwood/Brougham 1990-1996.....	7-8
Eldorado/Seville 1992-1995.....	8

Chevrolet (GEO)

Avalanche 2003-2006.....	7
Blazer (con doble DIN) 2002-2005.....	8
Cavalier 2000-2005.....	9
Colorado 2004-2012.....	9
Express Van (tamaño completo) 2001-2002.....	10
Express Van (tamaño completo) 2003-2007.....	11
Impala 2000-2005.....	10
Kodiak 2003-2009.....	7

Oldsmobile

Achieva.....	1996-1998
Alero.....	1999-2004
Aurora.....	1995-2003
Bravada.....	1998-2004
Cutlass.....	1997-1999
Cutlass Supreme.....	1995-1997
Eighty-Eight.....	1994-1999
Intrigue.....	1998-2002
LSS.....	1996-1999
Ninety-Eight.....	1994-1996
Regency.....	1997-1998
Silhouette.....	2000-2004

Pontiac

Aztec.....	2001-2005
Bonneville.....	2000-2005
Grand Am.....	2001-2005
Montana.....	2000-2005
Sunfire.....	2000-2005

Suzuki

Aerio.....	2002
Esteem.....	1995-2003
Sidekick.....	1992-1998
Swift.....	1995-2001
Vitara.....	1999-2004
Grand Vitara.....	1999-2002
XL-7.....	2001-2002

Toyota

Matrix.....	2003-2004
-------------	-----------

Indice

Chevrolet (GEO) (seguido)

Malibu 2001-2003.....	11
Malibu Classic 2004-2005.....	11
Metro (GEO incluido) 1995-2001.....	12
Monte Carlo 2000-2005.....	12
SSR 2003-2006.....	13
S-10 Pickup (con doble DIN) 2002-2004.....	8
Silverado 2003-2006.....	7
Silverado Classic 2007.....	7
Suburban 2003-2006.....	7
Tahoe 2003-2006.....	7
Tracker (GEO incluido) 1992-2004.....	12
Trailblazer 2002-2009.....	14
Venture 2000.....	14
Venture 2001-2005.....	15

GMC

Canyon 2004-2012.....	9
Envoy 2002-2009.....	16
Savanna 2001-2002.....	10
Savanna 2003-2007.....	11
Sierra 2003-2006.....	7
Sierra Classic 2007.....	7
Sonoma (con doble DIN) 2002-2004.....	8
Top Kick 2005-2009.....	7
Yukon/Denali/XL 2003-2006.....	7

Honda

Passport 1998-2002.....	15
-------------------------	----

Hummer

H2 2003-2007.....	16-17
-------------------	-------

Isuzu

Ascender 2003-2009.....	16
Amigo 1998-2000.....	15
H-Series 2003-2008.....	7
i280/i350 2006.....	9
i290/i370 2007-2008.....	9
Rodeo 1998-2004.....	15
Rodeo Sport 2001-2003.....	15

Oldsmobile

Achieva 1996-1998.....	18
Alero 1999-2004.....	17
Aurora 1995-2003.....	17
Bravada 1998-2001.....	8
Bravada 2002-2004.....	16
Cutlass 1997-1999.....	18
Cutlass Supreme 1995-1997.....	18
Eighty-Eight 1994-1999.....	18
Intrigue 1998-2002.....	19
LSS 1996-1999.....	20
Ninety-Eight 1994-1996.....	18
Regency 1997-1998.....	20

Oldsmobile (seguido)

Silhouette 2000.....	14
Silhouette 2001-2004.....	15

Pontiac

Aztec 2001-2005.....	20
Bonneville 2000-2005.....	20
Grand Am 2001-2005.....	19
Montana 2000 (excepto SV6).....	14
Montana 2001-2005 (excepto SV6).....	15
Sunfire 2000-2005.....	19
Vibe 2003-2008.....	21

Suzuki

Aerio 2002.....	21
Esteem 1995-2003.....	22
Grand Vitara 1999-2002.....	12
Sidekick 1992-1998.....	12
Swift 1995-2001.....	12
Vitara 1999-2004.....	12
XL-7 2001-2002.....	12

Toyota

Matrix 2003-2004.....	21
-----------------------	----

Instrucciones para pestañas

Todos los vehículos.....	22-23
--------------------------	-------

Ensamble del kit

Ensamble del pre-kit, Cadillac Fleetwood/Brougham 1990-1996.....	23
Todos los vehículos.....	23-24

**Buick Century 1997-2005/
Regal 1995-2004**

1. Quite la pieza de moldura de plástico a la izquierda de la guantera y (1) tornillo Phillips que queda a la vista.
2. Suelte a presión el borde superior del panel del protector de rodillas.
3. Quite (1) tornillo Phillips del panel.
4. Quite el conjunto del cenicero y los (2) tornillos Phillips de cada lado.
5. Desenganche todo el bisel de la moldura del tablero y quite. (Figura A)
6. Abra las puertas y suelte las tapas de los extremos de cada lado del tablero.
7. Suelte y quite el panel del radio/conjunto de instrumentos.
8. Quite los (3) tornillos para retirar el radio.

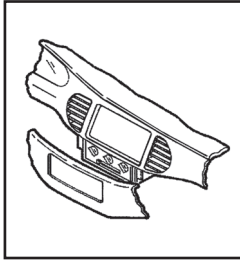
*(Figura A)*

Continuará al ensamble del kit

**Buick Le Sabre/Park
Avenue 1995-1999**

1. Suelte a presión el panel de la moldura del control de clima (de puerta a puerta) y quite los (4) tornillos Phillips expuestos. (Figura A, 1)
2. Saque a presión las rejillas del aire acondicionado y quite (1) tornillo Phillips expuesto en cada cavidad de la rejilla. (Figura A, 2)
3. Desenganche el bisel de la moldura del radio y quite.
4. Quite los tornillos que sujetan la unidad central de fábrica y desconecte el cableado. (Figura A, 3)

Continuará al ensamble del kit

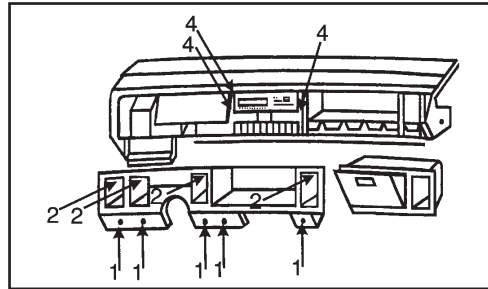
*(Figura A)***Buick Le Sabre/Park
Avenue 2000-2005**

1. Abra la puerta del conductor y suelte a presión y quite la tapa del extremo del tablero.
2. Suelte a presión y quite la moldura alrededor del centro del tablero. (Una pieza a la derecha y una a la izquierda del volante)
3. Suelte y retire el bisel del radio/instrumentos. (Figura A)
4. Quite los (2) tornillos para retirar el radio.

Continuará al ensamble del kit

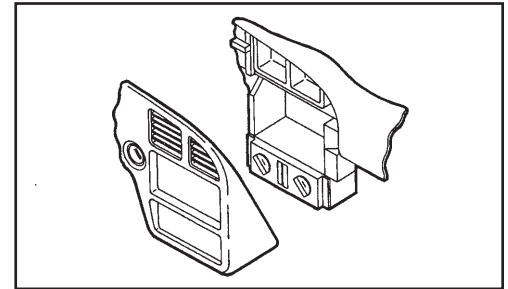
*(Figura A)*

Buick Rendezvous 2002-2007

1. Abra la consola central y retire los (2) tornillos al frente de la apertura de la consola. (Figura A)
 2. Quite los revestimientos de los portavasos y de la cavidad de almacenamiento junto a los portavasos, luego quite los tornillos. Suelte y quite el panel. (Figura B)
 3. Quite (2) tornillos de la parte inferior del bisel del radio/control de clima, desenganche y quite. (Figura C)
 4. Quite los (3) tornillos de cabeza hexagonal de 9/32" para retirar el radio. (Figura D)
- Continuará al ensamble del kit*

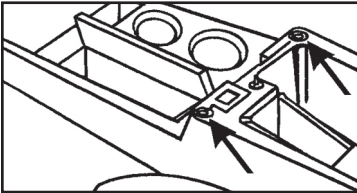

(Figura A)

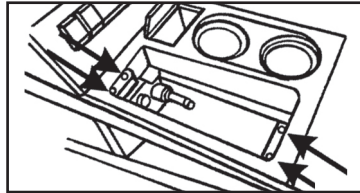

(Figura B)

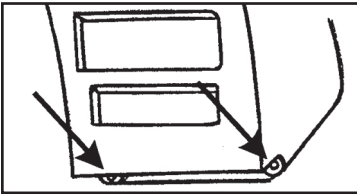

(Figura C)

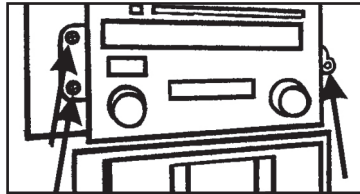

(Figura D)

Buick Riviera 1996-1999

1. Suelte a presión el panel del lado izquierdo, exponiendo (1) tornillo Phillips debajo del panel para retirar. (Figura A, 1)
 2. Quite (1) tornillo Phillips y suelte a presión el panel del lado derecho para exponer (1) tornillo Phillips debajo del panel y quite. (Figura A, 2)
 3. Suelte a presión la parte inferior del tablero que sobresale para soltar los (6) remaches de plástico y retire el panel. (Figura A, 3)
 4. Quite los (5) tornillos de cabeza hexagonal expuestos debajo de la parte que sobresale. (Figura A, 4)
 5. Suelte a presión el borde inferior del bisel de la moldura y luego, mientras sostiene la parte que sobresale, quite y quite el bisel de la moldura, retirando cualquier arnés necesario.
 6. Quite los (3) tornillos Phillips para retirar el control de clima.
 7. Quite los (2) tornillos Phillips para retirar el soporte posterior y (3) tornillos de cabeza hexagonal de 9/32" para retirar el radio.
- Continuará al ensamble del kit*

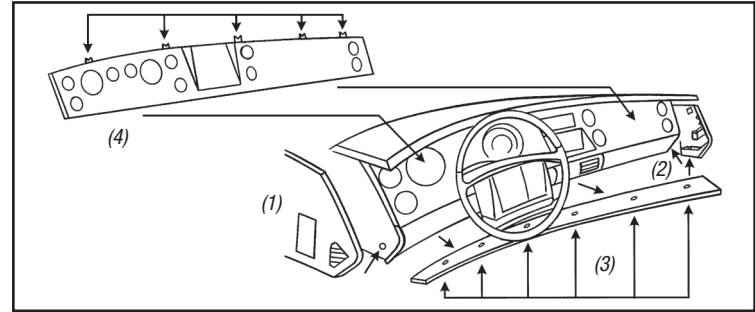

(Figura A)

Buick Roadmaster 1995-1996

1. Desenganche los lados del panel del tablero y quite. (Figura A, 1)
 2. Desenganche el panel debajo de la columna de dirección y quite. (Figura A, 2)
 3. Quite los (2) tornillos de 7mm de arriba del conjunto de instrumentos. (Figura A, 3)
 4. Ponga el freno de mano, encienda el vehículo y mueva la palanca de velocidades al cambio más bajo. Incline el volante hacia abajo, luego suelte a presión todo el panel del conjunto de instrumentos/radio y quite. (Figura A, 4)
 5. Quite los (3) tornillos de 7mm para retirar el radio. (Figura A, 5)
- Continuará al ensamble del kit*

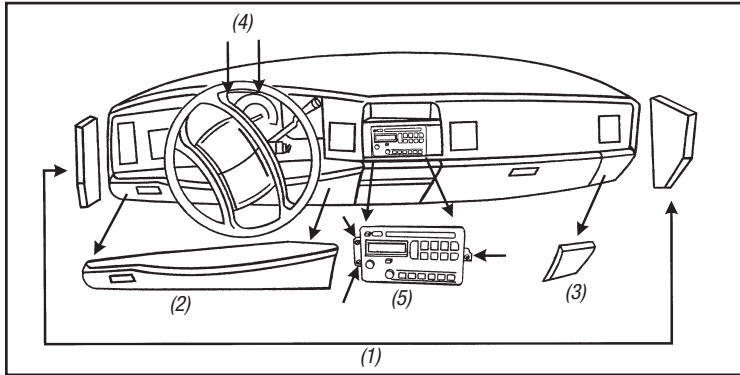

(Figura A)

Buick Skylark 1996-1998

1. Quite los (6) tornillos de 9/32" del interior de la guantera. (Figura A, 1)
 2. Debajo de la guantera y del protector de rodillas del conductor, quite (2) paneles de plástico girando los (2) sujetadores 1/4 de vuelta por lado. (Figura A, 3)
 3. Quite los (4) tornillos de 9/32" que quedan a la vista (2 por lado). (Figura A, 3)
 4. Suelte a presión el panel del lado del conductor al lado del pasajero. (Figura A, 3)
 5. Quite los (3) tornillos de 9/32" para quitar el radio. (Figura A, 5)
- Continuará al ensamble del kit*

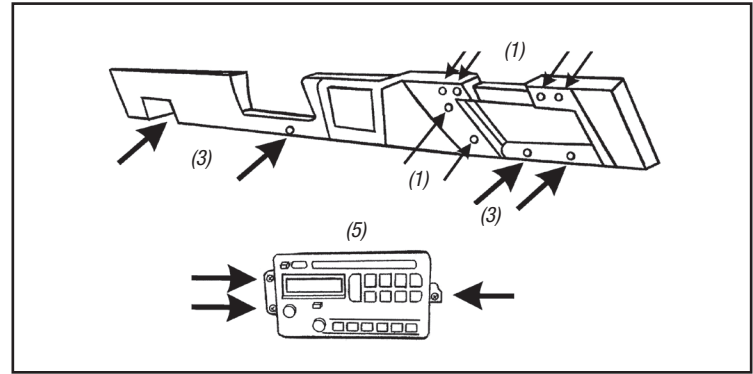

(Figura A)

**Cadillac Escalade ESV/EXT
2003-2006, Chevrolet
Avalanche 2003-2006/
Kodiak 2003-2009/
Silverado 2003-2006/
Silverado Classic 2007/
Suburban 2003-2006/
Tahoe 2003-2006, GMC
Sierra 2003-2006/Sierra
Classic 2007/Top Kick
2005-2009/Yukon/Denali/
XL 2003-2006, Isuzu
H-Series 2003-2008**

1. Suelte y quite el bisel del tablero. (Figura A)
2. Quite los (3) tornillos de 9/32" y quite el radio.

*Continuará al
ensamble del kit*

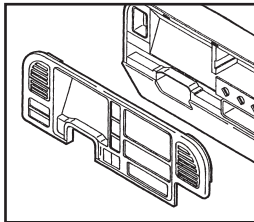

(Figura A)

Cadillac Fleetwood/Fleetwood Brougham 1990-1996

1. Suelte a presión cuidadosamente el panel de la moldura arriba de los control del aire acondicionado. (Figura A)
2. Quite los (2) tornillos de 7mm en la parte superior del bisel del radio/aire acondicionado, luego desenganche el panel y quite. (Figura B y C)

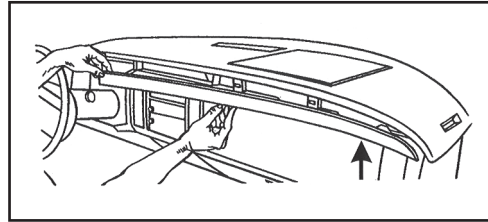

(Figura A)

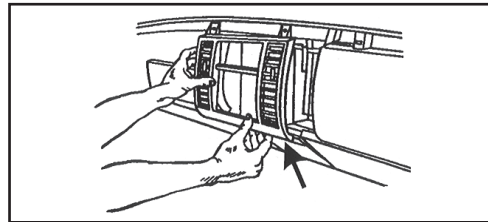

(Figura C)

3. Quite los (4) tornillos de 7mm que sostienen el radio, deslícelo hacia fuera, desconecte los arneses del radio y quite el radio. (Figura D)

*Continúe desarmando el soporte del radio
(página siguiente)*

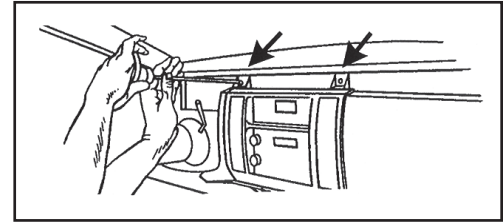

(Figura B)

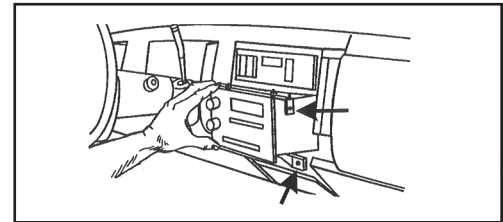

(Figura D)

Cadillac Fleetwood/ Fleetwood Brougham 1990-1996

Desensamblable del soporte del radio

1. Quite las (4) tuercas de 10mm, (2) arriba del radio y (2) abajo del radio que sostienen los soportes de montaje. Reserve los soportes y las tuercas para el ensamble del kit.

Continuará al ensamble del kit

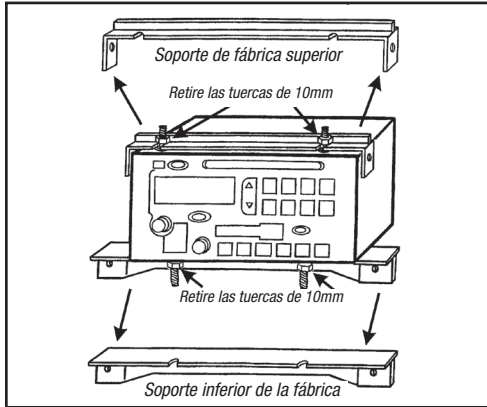

(Figura A)

Cadillac Eldorado/Seville 1992-1995

1. Usando una herramienta de remoción de panel, haga palanca para sacar el aro de la moldura del radio y retire. Tenga mucho cuidado al retirar. (Figura A)
2. Haga palanca gentilmente sobre el bisel de la moldura del cenicero/la palanca de velocidades y retire.

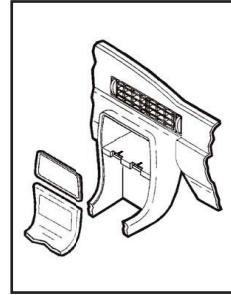

(Figura A)

- Precaución:** Algunos modelos están equipados con biseles de madera real.
3. Retire las (2) tuercas que sujetan la parte inferior de la unidad central de fábrica y desconecte el cableado.

Continuará al ensamble del kit

Chevrolet Blazer 2002-2005 (con doble DIN)/5-10 2002-2004 (con doble DIN), GMC Sonoma 2002-2004 (con doble DIN), Oldsmobile Bravada 1998-2001

1. Quite los (2) tornillos de cabeza hexagonal de 9/32" del panel del protector de rodillas.
2. Jale hacia abajo el panel y quite los tornillos de cabeza hexagonal de 9/32" expuestos en la parte inferior del bisel de la moldura del tablero. (Figura A)
3. Quite (1) tornillo Phillips de arriba del conjunto de instrumentos. (Figura A)
4. Desenganche el bisel de la moldura del tablero y quite. (Figura A)
5. Quite los (2) tornillos de cabeza hexagonal de 9/32" que sujetan la unidad central de fábrica y desconecte el cableado.

Continuará al ensamble del kit

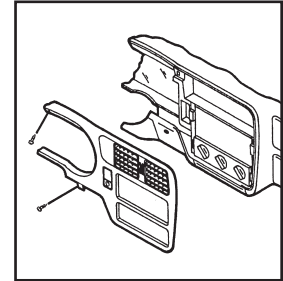

(Figura A)

**Chevrolet Colorado/GMC
Canyon 2004-2012, Isuzu
i280/i350 2006, Isuzu
i290/i370 2007-2008**

1. Suelte y quite todo el panel que rodea el radio y los controles del aire acondicionado. (Figura A)
2. Quite los (3) tornillos de 9/32" que sujetan el radio para retirarlo. (Figura B)

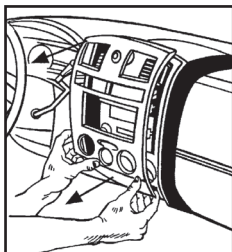

(Figura A)

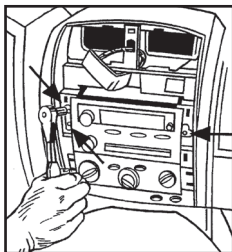

(Figura B)

Chevrolet Cavalier 2000-2005

1. Abra la puerta del conductor y quite el panel de fusibles en el extremo del tablero.
2. Abra la puerta del pasajero y quite el panel del extremo del tablero.
3. Quite (1) tornillo Phillips expuesto de cada lado.
4. Quite los (3) tornillos de la parte superior del revestimiento de la guantera.
5. Quite los (2) tornillos de la esquina superior izquierda de la cavidad de la guantera.
6. Quite (1) tornillo Phillips del conducto del desempañador.
7. Quite el ducto y (1) tornillo Phillips expuesto.
8. Quite la almohadilla del tablero y (3) tornillos Phillips expuestos en la parte superior del bisel de la moldura del radio.

Continuará al ensamble del kit

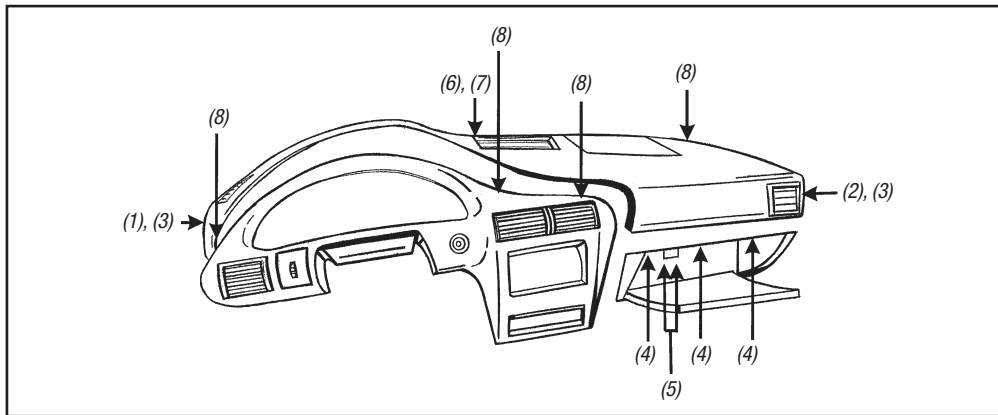

**Chevrolet Express Van (tamaño completo)/GMC
Savanna 2001-2002**

1. Suelte a presión y quite el pequeño panel de la moldura debajo de la columna de dirección. (Figura A)
2. Suelte a presión el panel del radio/clima/instrumentos. (Figura B)
3. Mueva la palanca de velocidades a la posición del primer cambio.
4. Gire el panel hacia la izquierda para levantarlo sobre la columna de dirección y quite.
5. Quite los (3) tornillos de cabeza hexagonal de 9/32" para retirar el radio. (Figura C)

Continuará al ensamble del kit

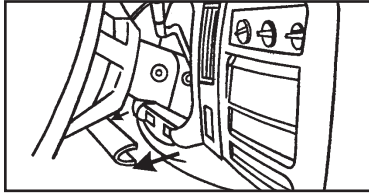

(Figura A)

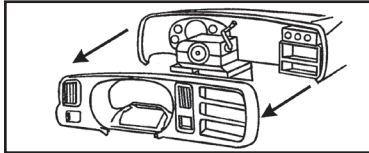

(Figura B)

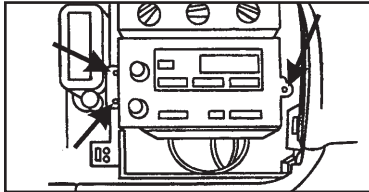

(Figura C)

Chevrolet Impala 2000-2005

1. Desenganche cada lado del bisel de la moldura del tablero (acceso a los fusibles) y quite (1) tornillo Phillips expuesto a cada lado.
 2. Quite (2) tornillos Phillips de abajo del conjunto de instrumentos.
 3. Desenganche el panel de la moldura sobre los pedales (no es necesario retirar el panel, puede dejarse colgando).
 4. Quite los (2) tornillos Phillips del panel para las rodillas.
 5. Desenganche el panel para las rodillas y quite (1) tornillo Phillips expuesto en el lado derecho de la columna de dirección.
 6. Desenganche y quite todo el bisel de la moldura del tablero. (Figura A)
- Continuará al ensamble del kit*

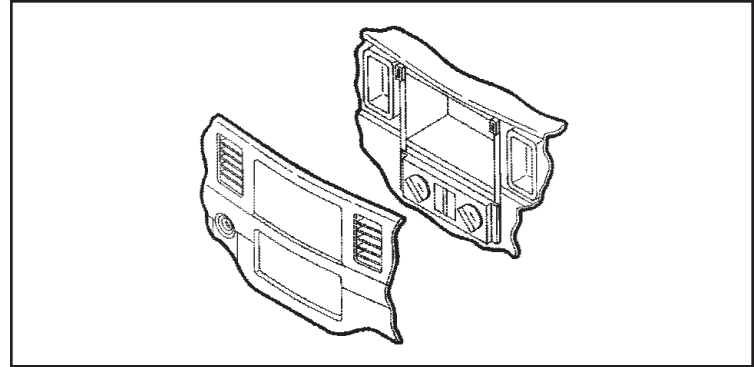

(Figura A)

Chevrolet Express Van (tamaño completo)/GMC Savanna 2003-2007

1. Quite los (2) pernos de 10mm de abajo del protector de rodillas debajo de la columna de dirección y quite el panel. (Figura A)
2. Quite los (2) pernos de 10mm del panel debajo del de la bolsa de aire del tablero del pasajero y quite el panel. (Figura B)
3. Quite las (2) tuercas de 10mm de la cavidad central interior entre los tomacorrientes. (Figura C)
4. Suelte y quite el panel del radio y conjunto de instrumentos. (Figura D)

(Quizá no sea necesario retirar el radio y el panel del conjunto de instrumentos para obtener acceso al radio.)

5. Quite los (3) pernos de 9/32" para quitar el radio. (Figura D)
- Continuará al ensamble del kit*

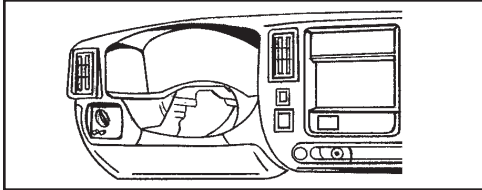

(Figura A)

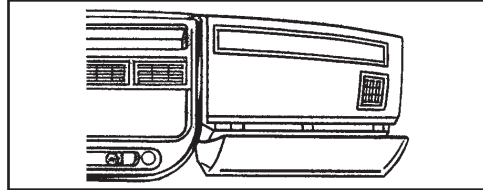

(Figura B)

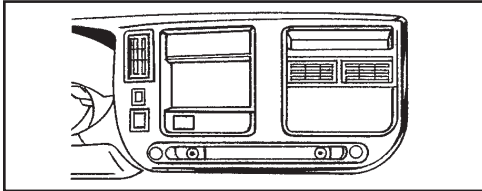

(Figura C)

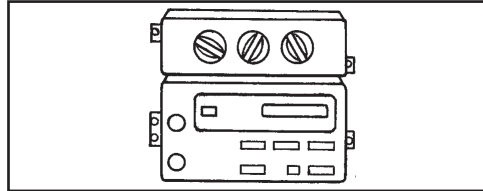

(Figura D)

Chevrolet Malibu 2001-2003/Malibu Classic 2004-2005

1. Suelte y quite el bisel del radio. (Figura A, 1)
2. Quite los (3) pernos y quite el radio. (Figura A, 2)

Continuará al ensamble del kit

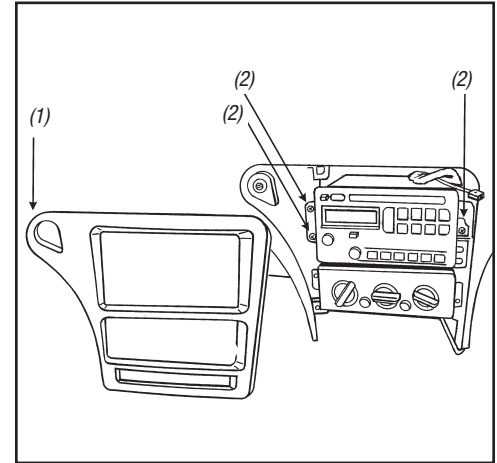

(Figura A)

**Chevrolet Metro (GEO incluido)/
Suzuki Swift 1995-2001**

1. Quite el cenicero y los (2) tornillos Phillips expuestos. (Figura A)
2. Quite los (2) tornillos Phillips de arriba de la apertura del radio. (Figura A)
3. Desenganche el bisel de la moldura del radio y desconecte el cableado del encendedor.
4. Quite los (2) tornillos que sujetan cada lado de la unidad central de fábrica y (1) tornillo del soporte trasero.
5. Deslice la unidad hacia afuera y desconecte el cableado.

Continuará al ensamble del kit

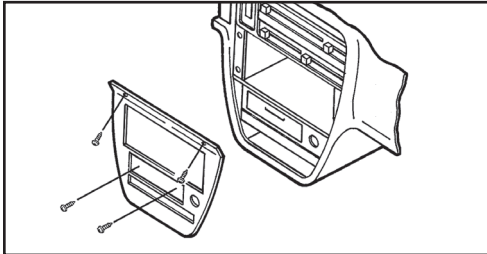

(Figura A)

**Chevrolet Monte Carlo
2000-2005**

1. Desenganche el panel de la moldura sobre los pedales (*no es necesario retirar el panel, puede dejarse colgando*). (Figura A)
2. Quite los (2) tornillos de 9/32" del panel para las rodillas y desenganche el panel.
3. Suelte a presión la cubierta del panel de fusibles del lado del conductor y quite (1) tornillo de 9/32".
4. Abra la guantera y quite (1) tornillo de 9/32" de la esquina superior izquierda.
5. Quite los (3) tornillos de 9/32" que sujetan la unidad central de fábrica y desconecte el cableado.

Continuará al ensamble del kit

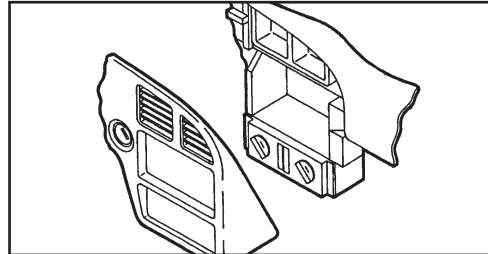

(Figura A)

Chevrolet Tracker (GEO incluido) 1992-2004, Suzuki Sidekick 1992-1998/Vitara 1999-2004/Grand Vitara 1999-2002/XI-7 2001-2002

1. Quite el encendedor y las perillas de control del clima.
2. Quite el cenicero y (1) tornillo expuesto.
3. Jale el conjunto de control del clima y quite los (2) tornillos expuestos.
4. Desenganche el bisel de la moldura del radio. (Figura A)
5. Quite los (4) tornillos de la unidad central de fábrica, deslice la unidad hacia fuera y desconecte el cableado.

Continuará al ensamble del kit

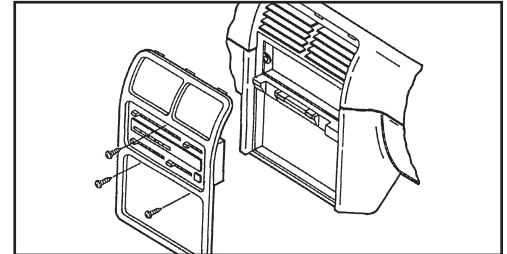

(Figura A)

Chevrolet SSR 2003-2006

1. Suelte y quite las (3) perillas de control del clima. (Figura A)
2. Suelte y quite el panel largo de moldura debajo del radio y de la bolsa de aire del pasajero. (Figura B)
3. Desenganche y quite el panel de moldura pequeño a la izquierda del volante. (Figura C)
4. Quite los (5) tornillos de 9/32" que sujetan el radio/panel de instrumentos y luego desenganche y quite el panel. (Figura D)
5. Quite los tornillos que sujetan la unidad central de fábrica y desconecte el cableado.
Continuará al ensamble del kit

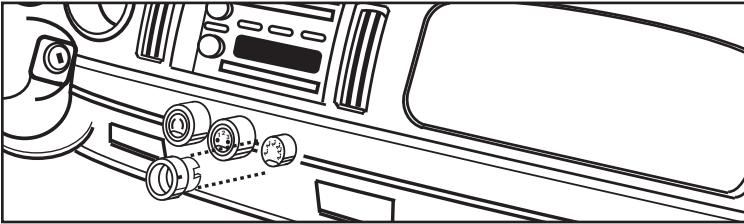

(Figura A)

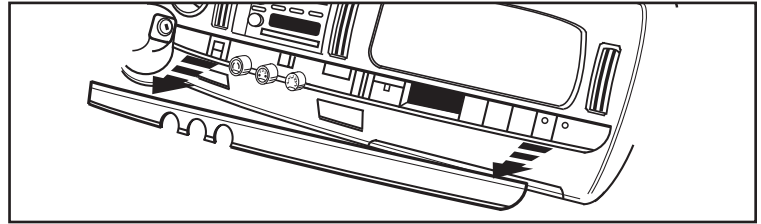

(Figura B)

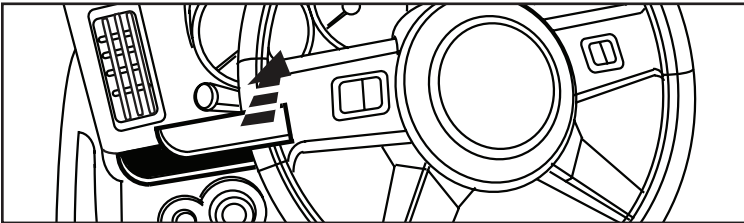

(Figura C)

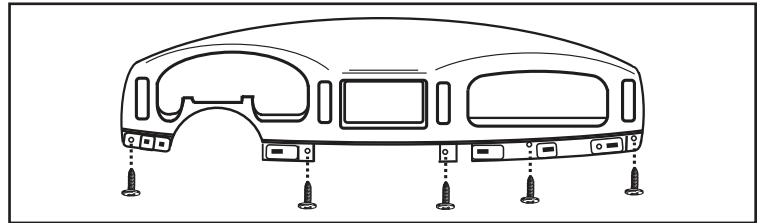

(Figura D)

Chevrolet Trailblazer 2002-2009

1. Quite los (2) tornillos Phillips del interior del conjunto de instrumentos. (Figura A, 1)
2. Quite (1) tornillo Phillips debajo de los controles del clima a la izquierda del tomacorriente. (Figura A, 2)
3. Quite los (2) tornillos de cabeza hexagonal de 7mm debajo de la columna de dirección y baje el panel.
4. Suelte y quite el radio. (Tenga cuidado al jalar sobre el interruptor de las luces intermitentes.) Quite los (3) tornillos de cabeza hexagonal de 7mm para retirar el radio.

Continuará al ensamble del kit

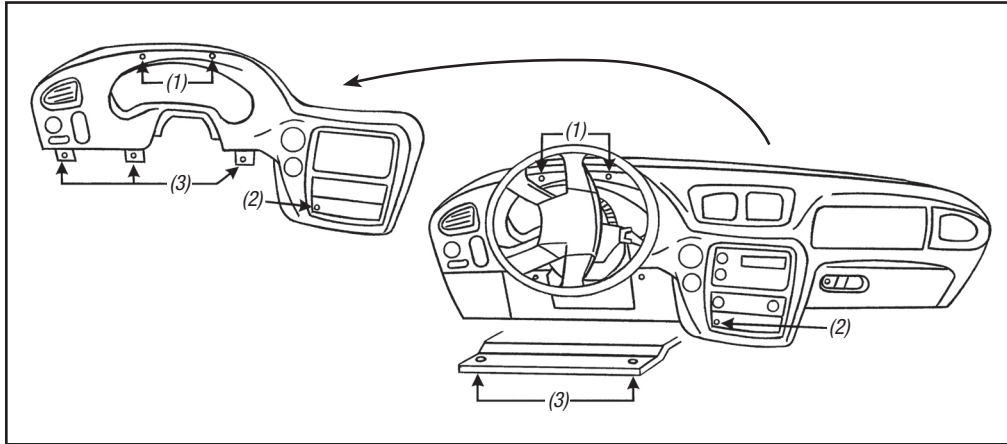

(Figura A)

**Chevrolet Venture/
Oldsmobile Silhouette
2000, Pontiac Montana
2000 (excepto SV6)**

1. Quite el cenicero y (1) tornillo Phillips expuesto en la cavidad del cenicero.
2. Quite (1) tornillo Phillips del compartimiento del encendedor.
3. Quite los (2) tornillos Phillips que sujetan la unidad central de fábrica y desconecte el cableado.

Continuará al ensamble del kit

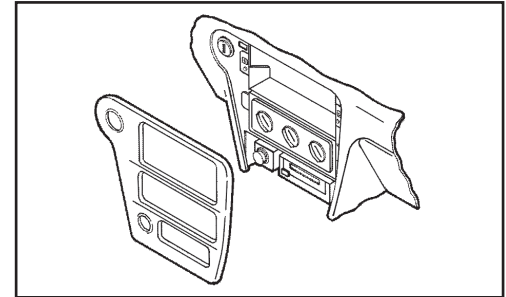

Chevrolet Venture 2001-2005, Oldsmobile Silhouette 2001-2004, Pontiac Montana 2001-2005 (excepto SV6)

1. Quite el cenicero y (1) tornillo Phillips expuesto en la cavidad del cenicero. (Figura A)
2. Quite (1) tornillo Phillips del compartimiento del encendedor. (Figura B y C)
3. Quite los (2) tornillos Phillips que sujetan la unidad central de fábrica y desconecte el cableado. (Figura D)

Continuará al ensamble del kit

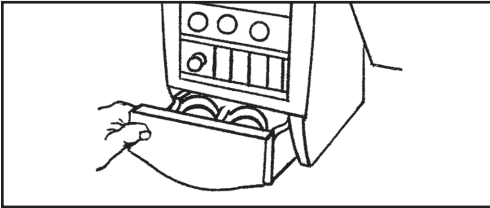

(Figura A)

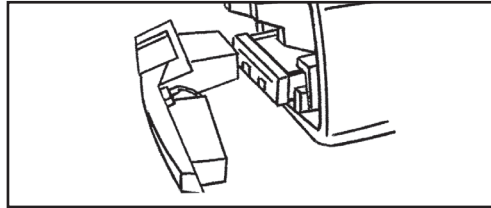

(Figura B)

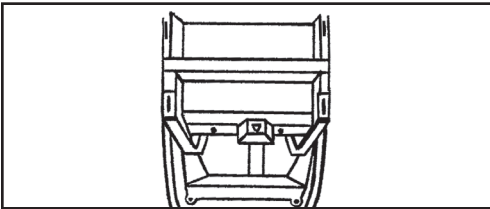

(Figura C)

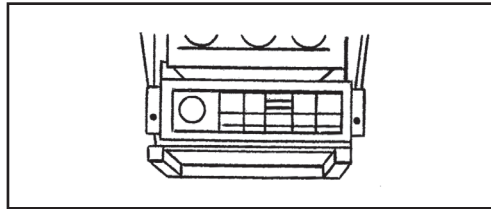

(Figura D)

Honda Passport 1998-2002, Isuzu Amigo 1998-2000/Rodeo 1998-2004/Rodeo Sport 2001-2003

1. Quite el cenicero y (1) tornillo Phillips expuesto en la cavidad del cenicero. Desenganche y retire el panel de moldura que rodea el radio de fábrica. (Figura A)
2. Retire los (4) tornillos Phillips que sujetan el radio de fábrica y desconecte el cableado.

Continuará al ensamble del kit

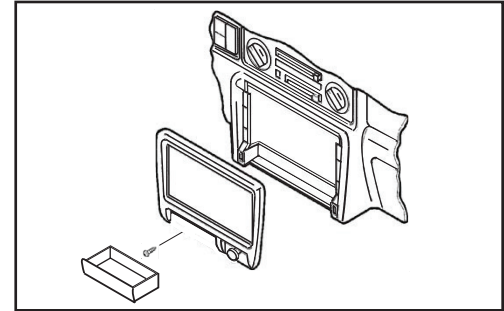

(Figura A)

GMC Envoy 2002-2009, Isuzu Ascender 2003-2009, Oldsmobile Bravada 2002-2004, Buick Ranier 2004-2007

1. Quite los (4) tornillos Phillips, (2) de la izquierda y (2) de la derecha del panel alfombrado. (Figura A)
2. Deslice el panel alfombrado hacia abajo y hacia atrás para revelar los (2) tornillos Phillips y quite. (Figura B)
3. Suelte a presión el bisel del radio y desconecte el encendedor y los accesorios. (Figura C)

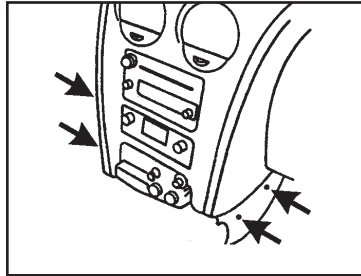

(Figura A)

4. Quite los (3) tornillos y quite el radio. (Figura C)

Continuará al ensamble del kit

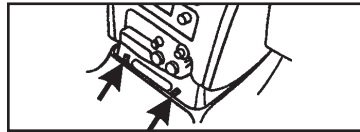

(Figura B)

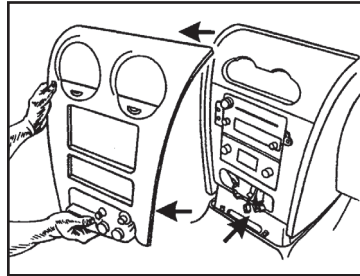

(Figura C)

Hummer H2 2003-2007

1. Abra la consola central y quite los (4) tornillos de 9/32" de la caja de la consola y quite la caja. (Figura A)
2. Quite los (4) tornillos Phillips de la bisagra sobre la puerta de la consola al interior de la misma y quite la puerta. (Figura B)
3. Afloje (1) tornillo Torx T-15 en el lado orientado hacia el frente de la

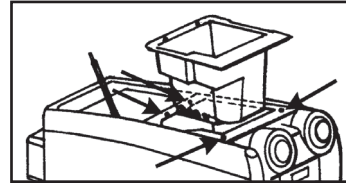

(Figura A)

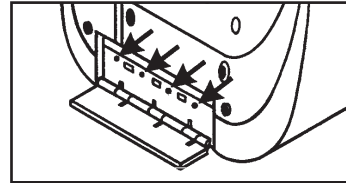

(Figura B)

4. Desenganche el ensamble de la moldura del portavasos/palanca de velocidades y quite. (Figura D)
5. Quite los (6) tornillos Phillips de la parte superior de la consola central.
6. Quite los (2) tornillos Phillips de la cavidad interior en la parte posterior

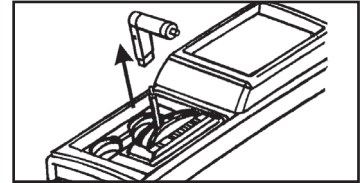

(Figura C)

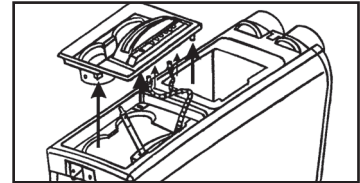

(Figura D)

Hummer H2 2003-2007

de la consola central, luego desenganche y quite.

7. Retire (1) perno de 10mm a la derecha de la palanca de velocidades. (Figura E)
8. Quite los (2) tornillos Phillips debajo de la caja de la consola del lado del conductor y (2) tornillos Phillips debajo de la parte superior de la

moldura de la consola en el lado del pasajero. (Figura E)

9. Deslice el ensamble del control hacia atrás. (Figura F)
10. Quite los (2) pernos Torx T-30 de la parte superior de la moldura del radio/control de clima y desenganche y quite. (Figura G)
11. Quite los (3) tornillos de 9/32" que sostienen el radio dentro. (Figura G)

Continuará al ensamble del kit

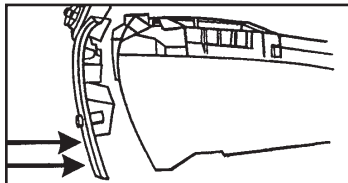

(Figura E)

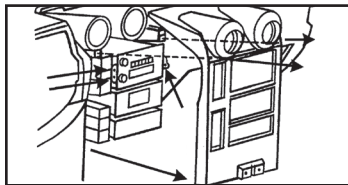

(Figura G)

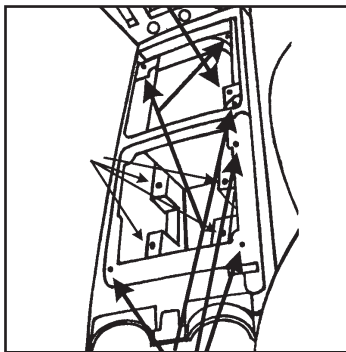

(Figura F)

Oldsmobile Alero 1999-2004

1. Quite la perilla de la palanca de velocidades con un pequeño destornillador para retirar el gancho en U de la parte frontal de la palanca de velocidades y jale hacia arriba.
2. Suelte y quite el panel de moldura de la palanca de velocidades.
3. Desenganche y quite el panel del radio y el control del clima jalando desde abajo. (Figura A)
4. Quite los (3) tornillos de 9/32" del radio y quitelo.

Continuará al ensamble del kit

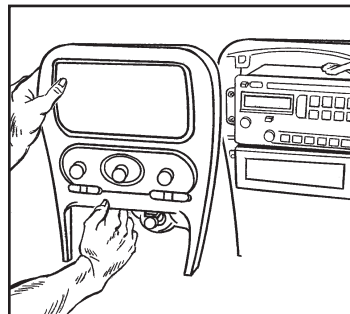

(Figura A)

Oldsmobile Aurora 1995-2003

1. Desenganche el bisel de la moldura del radio y quite el bisel. (Figura A)
2. Retire los (2) tornillos de 7mm que sujetan la unidad central de fábrica y desconecte el cableado.

Continuará al ensamble del kit

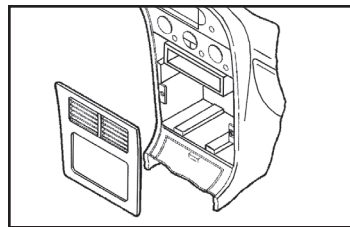

(Figura A)

Oldsmobile Achieva 1996-1998

1. Abra la guantera, presione hacia dentro las paredes del revestimiento de la guantera y quite el revestimiento.
2. Quite los (10) tornillos de cabeza Torx de la guantera.
3. Quite los (2) tornillos de cabeza hexagonal de 9/32" debajo de la columna de dirección.
4. Desenganche el bisel de la moldura del tablero. (Figura A)
5. Quite los tornillos que sujetan la unidad central de fábrica y desconecte el cableado.

Continuará al ensamble del kit

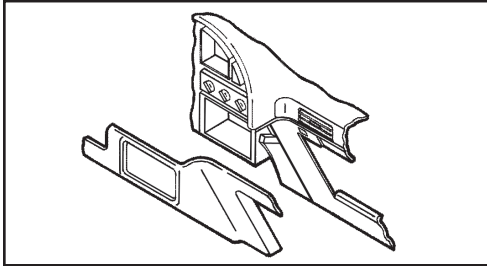

(Figura A)

Oldsmobile Cutlass 1997- 1999/Cutlass Supreme 1995-1997

1. Desenganche el bisel de la moldura del radio y quite. (Figura A)
2. Quite los (2) tornillos de cabeza hexagonal de 9/32" que sujetan la unidad central de fábrica y desconecte el cableado.

*Continuará al
ensamble del kit*

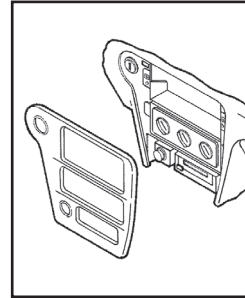

(Figura A)

Oldsmobile Eighty-Eight 1994-1999

1. Desenganche el bisel de la moldura del radio y quite.
2. Quite los (2) tornillos de cabeza hexagonal de 9/32" que sujetan la unidad central de fábrica y desconecte el cableado.

Continuará al ensamble del kit

Oldsmobile Ninety-Eight 1994-1996

1. Abra la guantera y quite los (2) tornillos de cabeza hexagonal que sujetan la moldura de madera.
2. Suelte a presión la moldura de madera y quite.
3. Quite los (2) tornillos de cabeza hexagonal de debajo del bisel de la moldura del radio.
4. Levante el bisel y retírelo.
5. Quite los (3) tornillos Phillips de cabeza hexagonal que sujetan la unidad central de fábrica y desconecte el cableado.

Continuará al ensamble del kit

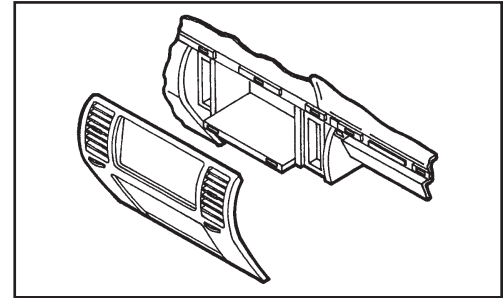

(Figura A)

Oldsmobile Intrigue 1998-2002

1. Abra el compartimiento de almacenamiento de la consola central y quite los (2) tornillos de cabeza hexagonal de 9/32" expuestos.
2. Quite la consola central.
3. Desenganche el bisel de la moldura del radio y quite.
4. Quite los (2) tornillos de cabeza hexagonal de 9/32" que sujetan la unidad central de fábrica y desconecte el cableado.

Continuará al ensamble del kit

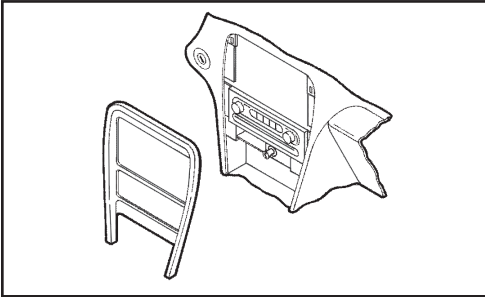

(Figura A)

Pontiac Grand Am 2001-2005

1. Suelte y quite el bisel de la moldura del radio. (Figura A, 1)
2. Quite los (3) tornillos de 9/32" de los soportes del radio y quite el radio. (Figura A, 2)

Continuará al ensamble del kit

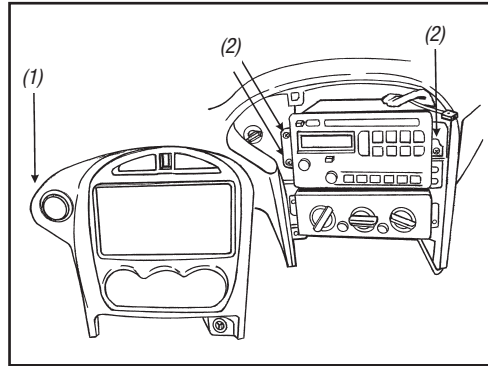

(Figura A)

Pontiac Sunfire 2000-2005

1. Abra la guantera y quite (2) tornillos Phillips expuestos en el borde superior derecho del bisel de la moldura del radio.
2. Desenganche el bisel y quite.
3. Quite los (2) tornillos de cabeza hexagonal de 7 mm que sujetan la unidad central de fábrica y desconecte el cableado.

Continuará al ensamble del kit

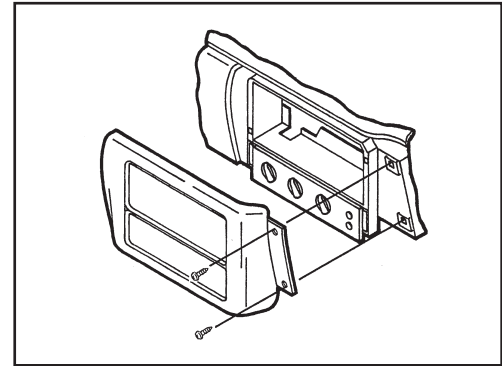

(Figura A)

Oldsmobile L55 1996-1999/ Regency 1997-1998

1. Abra la guantera y quite dos bisese de moldura centrales unidos con tornillos. (Figura A, 1)
2. Suelte y quite el bisel de la moldura del radio. (Figura A, 2)
3. Quite los (3) tornillos de cabeza hexagonal de 9/32" y quite el radio. (Figura A, 3)

Continuará al ensamble del kit

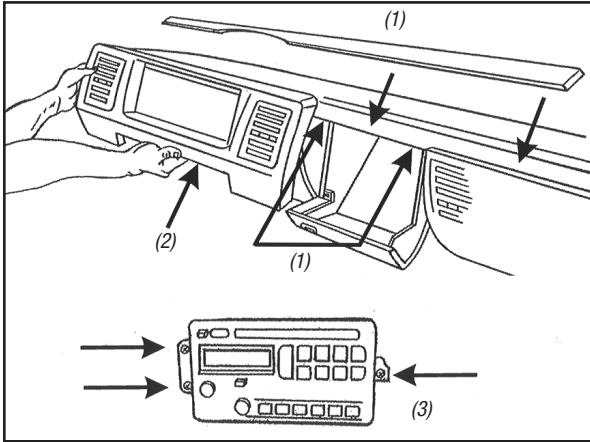

(Figura A)

Pontiac Aztec 2001-2005

1. Jale y saque los insertos de los portavasos.
2. Quite (1) tornillo Phillips expuesto del interior del portavasos.
3. Suelte a presión y quite la moldura de la palanca de velocidades con los portavasos.
4. Quite los (2) tornillos Torx #15 de la parte inferior del bisel del radio/clima.

Continuará al ensamble del kit

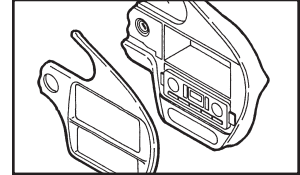

(Figura A)

Pontiac Bonneville 2000-2005

1. Quite los (2) tornillos Phillips del conjunto de instrumentos. (Figura A)
2. Desenganche la moldura de la ignición y quite. (Figura B)
3. Desenganche el bisel del control de clima/moldura del radio y quite.
4. Apriete los ganchos de resorte a cada lado de la unidad central de fábrica y quite. (Figura C)

Continuará al ensamble del kit

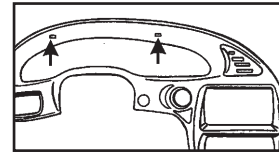

(Figura A)

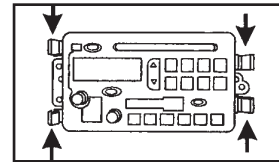

(Figura C)

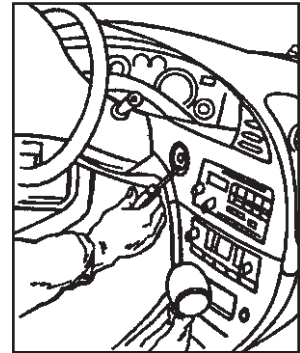

(Figura B)

**Pontiac Vibe 2003-2008,
Toyota Matrix 2003-2004**

1. Desenganche el borde inferior del panel de la moldura del radio y luego levante y retire. (Figura A)
2. Retire los (4) pernos de 10mm que sujetan el radio de fábrica. (Figura B)

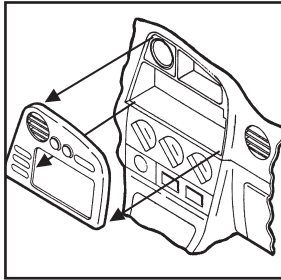
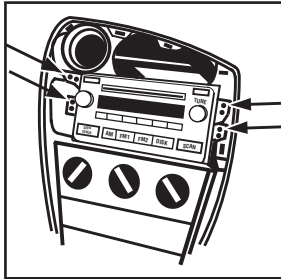
*(Figura A)**(Figura B)*

*Continuar con el
ensamble del kit*

Suzuki Aerio 2002

1. Desenganche el bisel de la moldura del tablero y quite. (Figura A)
2. Quite los (4) tornillos Phillips que sujetan la unidad central de fábrica y desconecte el cableado.

Continuará al ensamble del kit

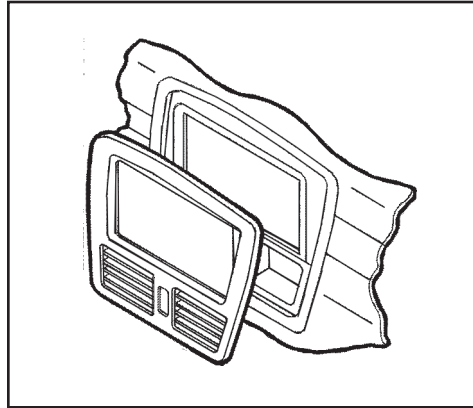
*(Figura A)***Suzuki Esteem 1995-2003**

1. Quite las perillas del control de clima.
2. Quite (1) tornillo Phillips localizado arriba de la apertura del radio. (Figura A)
3. Desenganche el bisel de la moldura del radio. (Figura A)
4. Quite los (4) tornillos de la unidad central de fábrica, deslice la unidad hacia fuera y desconecte el cableado.

Continuará al ensamble del kit

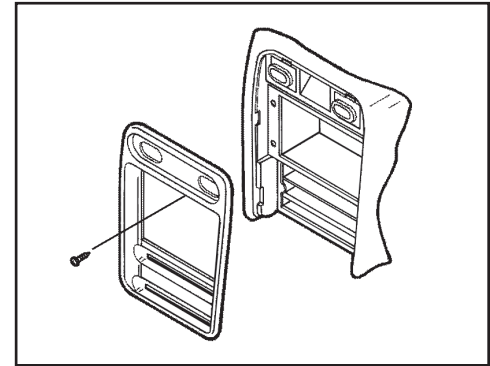
*(Figura A)*

Todos los vehículos

1. GM vehicles

Cortar el pestañas marcadas en los soportes de radio como se muestra. (Figura A)

2. Chevy Metro/Tracker, y Suzuki vehicles

Cortar el pestañas marcadas en los soportes de radio como se

muestra. (Figura B)

3. Cadillac Fleetwood/Brougham

Cortar el pestañas marcadas en los soportes de radio como se muestra. (Figura C)

4. Isuzu Amigo/Rodeo/Rodeo Sport

Cortar el pestañas marcadas en

los soportes de radio como se muestra. (Figura D)

5. Toyota Matrix/Pontiac Vibe

Cortar el pestañas marcadas en los soportes de radio como se muestra. (Figura E1) Cortar el (4) pestañas de la placa de montaje de la radio. (Figura E2)

6. Cadillac Eldorado/Seville

Cortar el pestañas marcadas en los soportes de radio como se muestra. (Figura F1) Cortar el (1) pestañas de la placa de montaje de la radio. (Figura F2)

Continuará al ensamble del kit

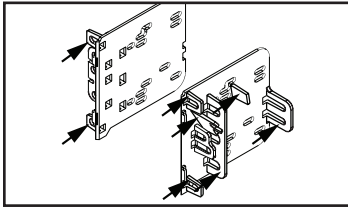

(Figura A)

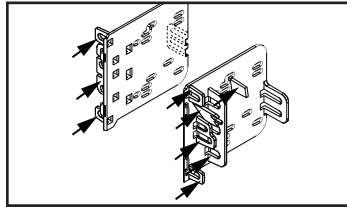

(Figura C)

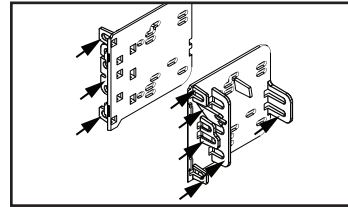

(Figura E1)

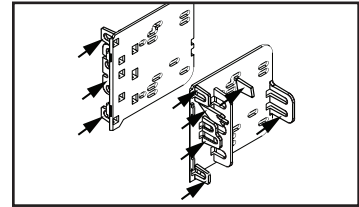

(Figura F1)

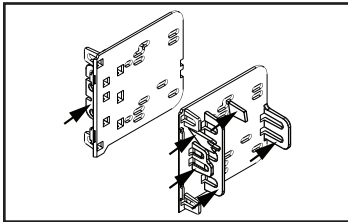

(Figura B)

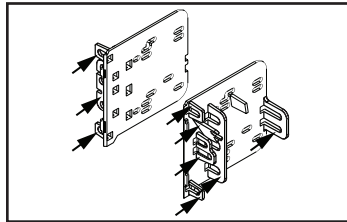

(Figura D)

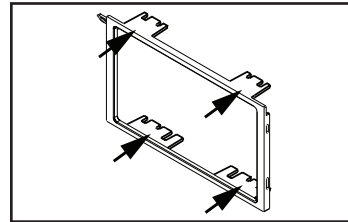

(Figura E2)

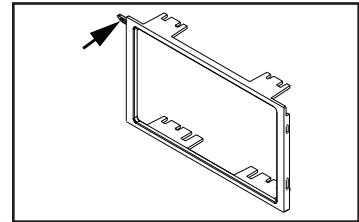

(Figura F2)

Ensamble del pre-kit para Cadillac Fleetwood/Brougham 1990-1996

1. El uso de los pernos del carro y las tuercas Keps suministrados, monte los soportes de fábrica a la asamblea de radio-trim-placa / radio-soporte (teniendo en cuenta que el soporte es de primera y cuál es la parte inferior).

Continuar Ensamble del kit "Todos los vehículos"

***Nota:** Figura A muestra la radio instalada únicamente con fines ilustrativos.

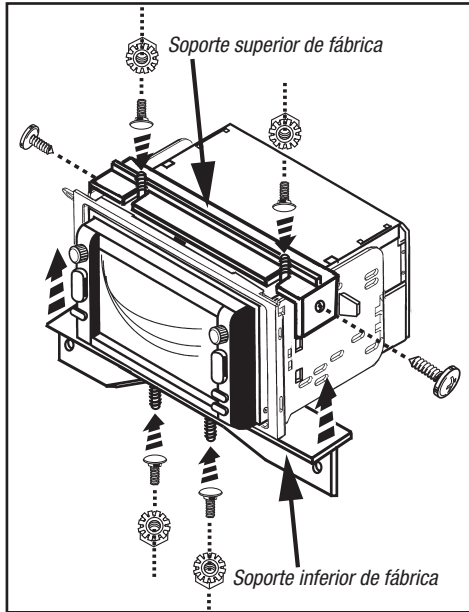

*(Figura A)

Todos los vehículos

Para ambas aplicaciones:

1. Inserte los soportes de radio hasta el borde de la placa de montaje de la radio. (Figura A)

Para provisión de radio ISO con bolsillo:

2. Seguro el bolsillo a los soportes de radio con (4) # 8 x 3/8 "tornillos Phillips suministrados.
3. Quite la manga de metal DIN y el anillo de moldura del radio de mercado secundario.
4. Inserte la radio a través de la parte trasera de la bolsa completado asegurar, y con los tornillos suministrados con la radio. (Figura B1)

Continúe "Todas las aplicaciones"

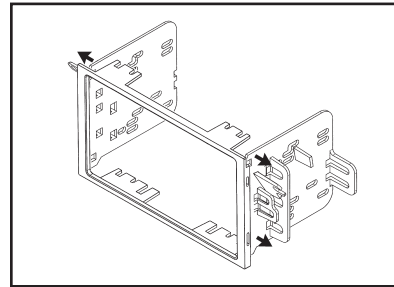

(Figura A, para ambas aplicaciones)

Provisión de radio ISO DDIN:

2. Inserte la radio en el conjunto completado por la parte posterior, y con los tornillos suministrados con la radio. (Figura B2)

Continúe "Todas las aplicaciones"

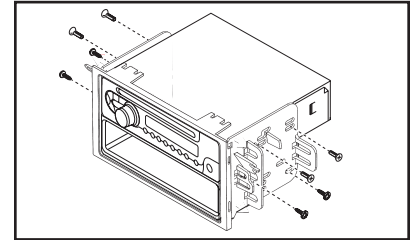

(Figura B1)

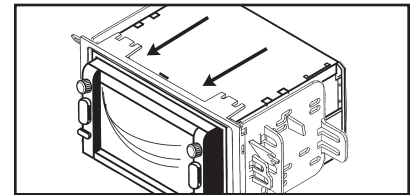

(Figura B2)



Todos los vehículos (seguido)

Todas las aplicaciones:

1. Localice el arnés de cableado de fábrica y el conector de la antena en el tablero y haga todas las conexiones necesarias al radio. Metra recomienda que use adaptadores adecuados de acoplamiento de Metra y/o de AXXESS. Pruebe el radio para verificar que funcione correctamente.
2. Seguro el conjunto completo en el tablero y volver a montar el tablero en orden inverso al de desmontaje.

Nota: Para el Cadillac Eldorado/Seville 1992-1995.

(1) Alinee las pestañas de la parte inferior del conjunto de soporte de la placa / de radio de corte de radio con muescas en la sub-guía. (Figura C)

(2) Asegure con los (2) pernos de carruaje y (2) tuercas Keps previstas. (Figura C)

Nota: Para el Buick Le Sabre, Oldsmobile Aurora y el Pontiac Bonneville,

(1) los clips (3) la velocidad y tornillos suministrados con el kit tendrá que ser instalado en el sub-tablero donde los agujeros de los tornillos se alinean en el kit.

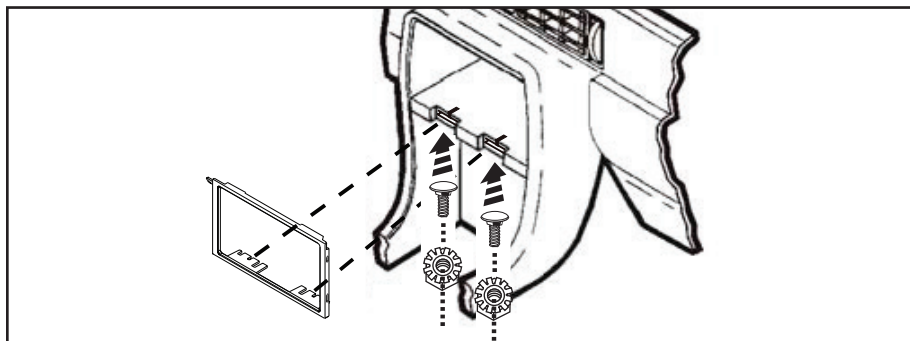

(Figura C)

IMPORTANTE

Si tiene dificultades con la instalación de este producto, llame a nuestra línea de soporte técnico al **1-800-253-TECH**. Antes de hacerlo, revise las instrucciones por segunda vez y asegúrese de que la instalación se haya realizado exactamente como se indica en las instrucciones. Por favor tenga el vehículo desarmado y listo para ejecutar los pasos de resolución de problemas antes de llamar.



EL CONOCIMIENTO ES PODER

Mejore sus habilidades de instalación y fabricación inscribiéndose en la escuela de dispositivos electrónicos móviles más reconocida y respetada de nuestra industria. Regístrese en www.installerinstitute.com o llame al 800-354-6782 para obtener más información y avance hacia un futuro mejor.



Metra recomienda técnicos con certificación del Programa de Certificación en Electrónica Móvil (Mobile Electronics Certification Program, MECP).