

LSX Concepts

LSA High Mount Accessory Drive kit Supplement (ALT)

1. Install – Alternator Kit as per Instructions
2. Install Belt tensioner to Water Pump

Alternator – Connect to your harness as per your wiring harness instructions

3. Install – 6 Rib main accessory drive belt
4. Install – LSA Supercharger Drive as per instructions

If you have any questions or issues installing your kit, please feel free to call us and we will be happy to sort out any issues you're having with the install

LSX Concepts - 844-579-7927

LSX Concepts - High Mount Alternator Bracket (Corvette Belt Spacing)

Part Number # LSX-ALT-COR

www.lsxconcepts.com

Tool/Supplies List

Torque Wrench (ft-lbs)
Loctite Threadlocker Blue 242
8MM Allen Hex Socket
14MM Wrench

Installation Notes:

- Do not torque bolts until all parts are installed
- Apply Loctite to any bolts threaded into directly into the aluminum cylinder head, it is not needed on any bolts secured with a lock nut

1: Assemble as shown in the image below

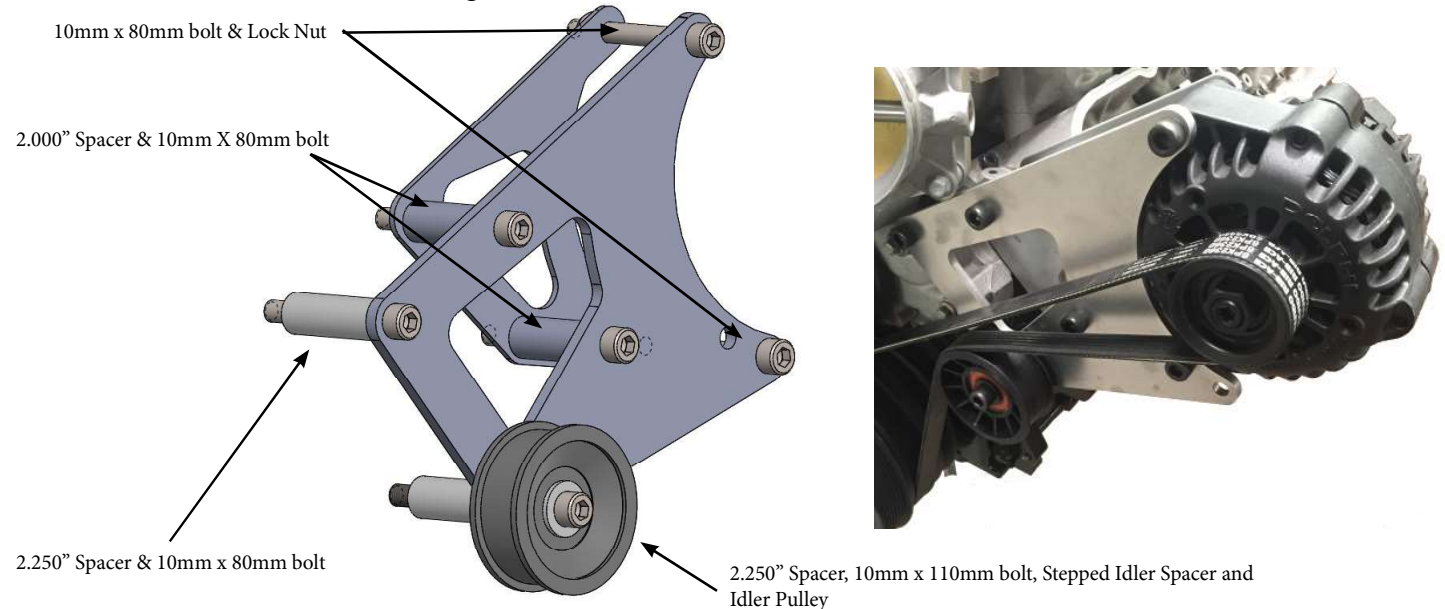

2: Torque all 10mm bolts to 25ft-lbs (34 N-m)

3: Install Serpentine Belt

- Standard deck block (9.240 deck height) with a 7.48 dia. damper, factory water pump, factory belt tensioner, Corvette alternator uses a 73" 6 rib serpentine belt

Due to variations beyond our control some applications may require a shorter or longer belt. use a belt length that will put the belt tensioner indicator in the mid travel position as shown in the picture to the left. (please see our belt measuring instructions if you need to measure for a belt)

Correct Tensioner Position



LSX Concepts - High Mount Alternator Bracket (Corvette Belt Spacing)

Part Number # LSX-ALT-COR

www.lsxconcepts.com

- Alternator bolt pattern Compatibility shown below

Two bolts patterns supported the 5.455 bolt pattern is found on GM Cars/trucks and Pickups with high mount alternators from the factory. Not compatible with common low mount alternators.

The 6.062 bolt pattern is commonly found on Corvettes (Alternators are commonly referred to as the Valeo Series alternator)

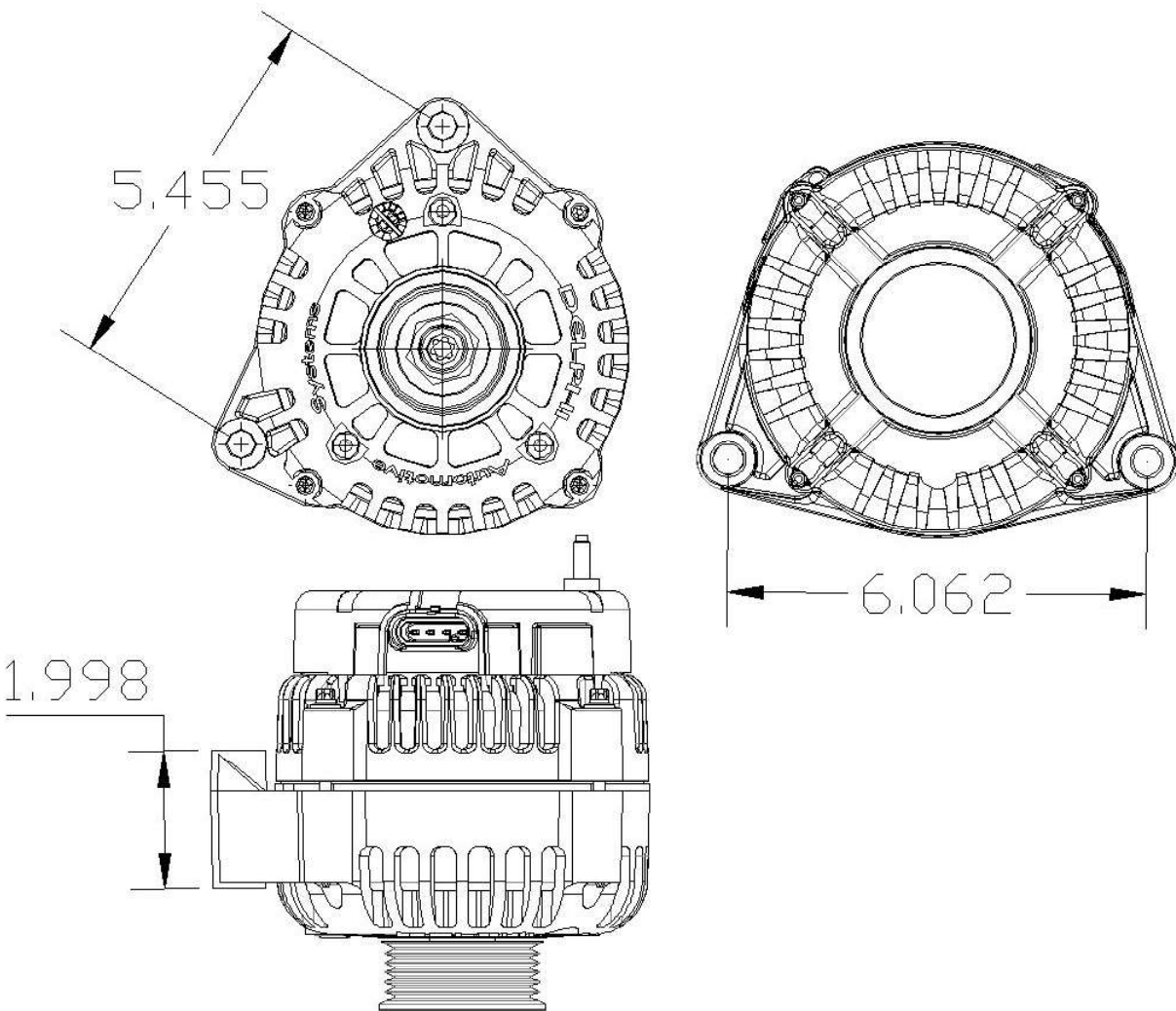

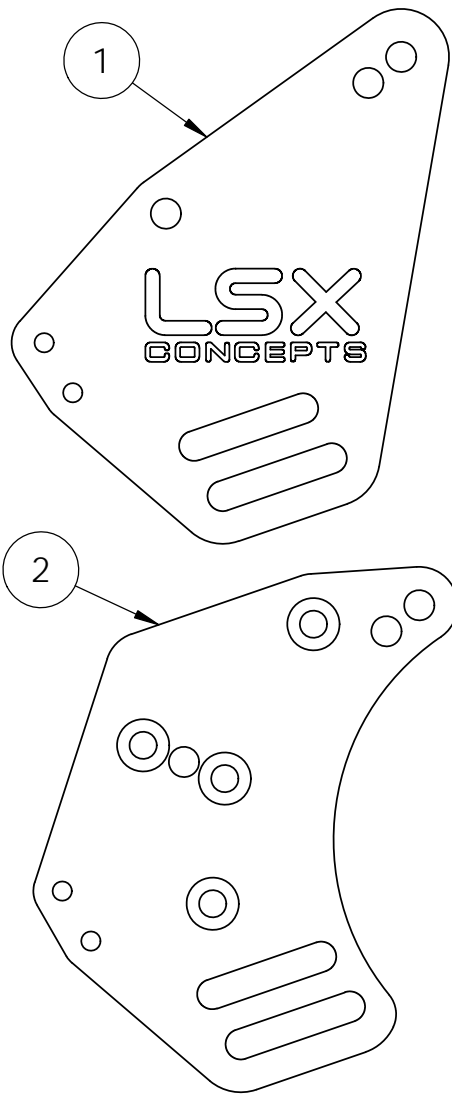

Parts		
No#	Qty	Desc
1	1	Front Plate
2	1	Rear Plate
3	1	Mounting Block
4	1	8 Rib Idler Pulley
5	2	Smooth Idler Pulley
6	2	10MM x 80MM Axle Bolt
7	1	1.250 Stainless Steel Washer
8	1	1.000 Stainless Steel Washer
9	1	10MM Axle Stud
10	3	Aluminum Chamfered Axle Washers
11	4	Aluminum Smooth Idler Pulley Spacers
12	2	Aluminum Ribbed Pulley Spacers
13	3	8 x 50MM Flat Head Allen Bolts
14	4	10MM Nylon Insert Lock Nuts (1 spare)
15	2	M8 x 80MM Hex Head Stainless Steel Bolts
16	2	M8 Washer
17	1	Water Pump Standoff Bracket (Assembled)
18	3	10MM Flange Mockup nuts (Black)
19	1	M8 x 20MM FHA
20	1	Torque Arm
21	1	1/4 Torque Arm Pin

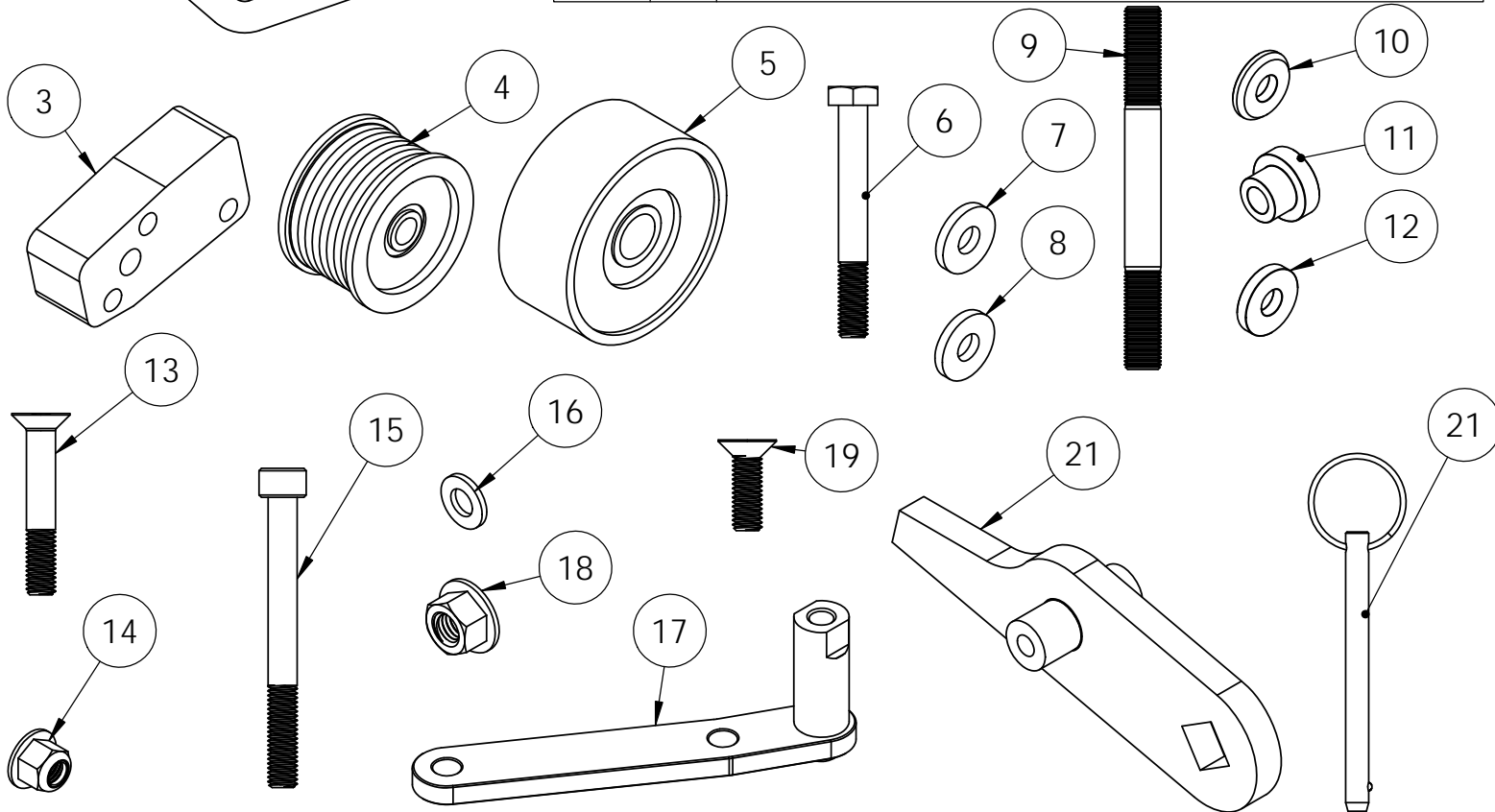

Scan this QR code to view these instruction online



Product Revision 3.2 - Nov 2019

These instructions are for LSA Race Drive Kits using the 3.2 configuration released in Nov of 2019. for previous version of these instructions please email sales@lsxconcepts.com

Pre Install Requirements

On engines not running High Mount A/C, We do recommend using the LSA 6 rib tensioner GM Part Number 12628025 for the main accessories with a 68MM Pulley (LSX Part Number 419604) to provide adequate clearance from the 6 rib belt tensioner to the race drive

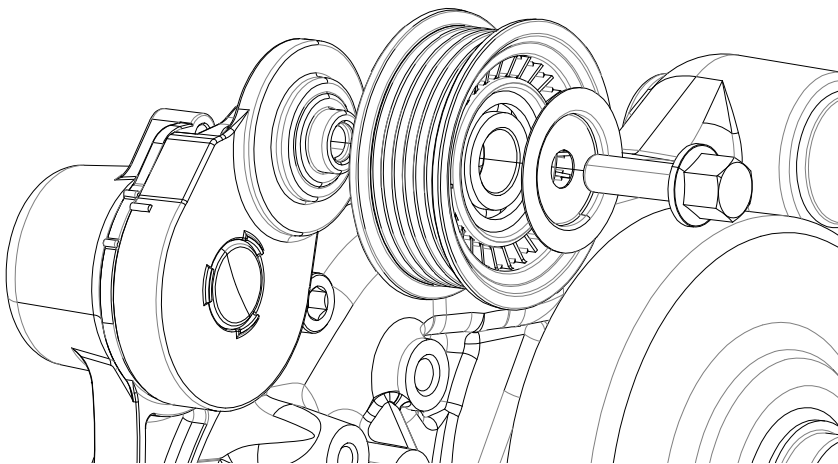

Compatible LSA Tensioner with pre installed 68MM Pulley

Scan QR Code



1: Pre Install Mock-up

First, verify fitment and pulley clearance. Install the LSA Race Drive as show in the following instructions without torquing the bolts or using the nylon insert locknuts. **(We have provided three 10MM black flange nuts to be used for mock-up purposes, do not use them when running the race drive).**

We recommended the race drive pulleys have at least 5/16 of an inch or more clearance from the main supercharger pulley and the crank pulley. If you do not have the minimum clearance you will need to move the race drive pulley to another hole or slot.

Once the drive is mocked up, measure it for a belt using the belt measuring instructions to find the correct belt length for you application. There are several ways to install the pulleys so it is best to verify the necessary clearance for you application, as it may differ from other combinations.

2: Water Pump Standoff Bracket Install

Install the water pump standoff bracket (#17) onto the water pump using the two M8x80MM Hex Head Bolts (#15) and M8 washers (#16) as shown. Apply a small amount of blue Loctite and tighten the bolts.

NOTE: If you are installing this kit with a High Mount A/C kit, install the A/C first

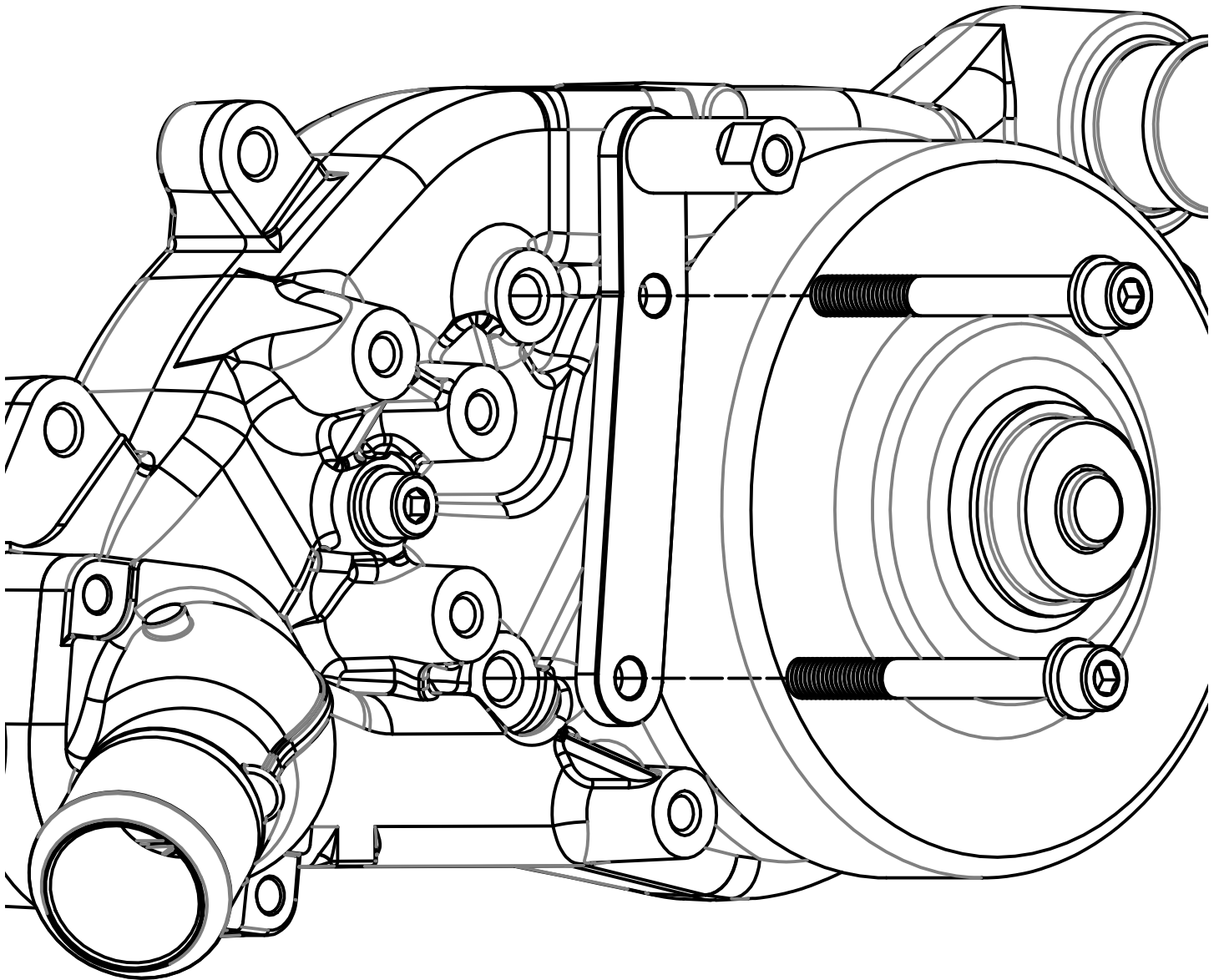

3: Pulley Positioning

Determine the appropriate pulley position for the two main smooth pulleys on the race drive.

The upper pulley has two positions, The lower position is for superchargers running stock supercharger pulleys and the upper position is for all smaller overdrive pulleys.

It is best to test fit and determine the best position for your combination. It is recommended that you have at least 5/16 of an inch clearance between the upper supercharger pulley and the race drive upper pulley. If you do not have at least 5/16 of an inch move the pulley to the lower position.

During test fitting also check clearance on the lower pulley, the lower pulley should have at least 5/16 clearance to the crank pulley through the sweep of the slot. The lower slot should be usable for all pulley up to about 8.5 inches in diameter. For pulleys larger than 8.5 inches use the upper slot. It May be necessary to trial fit the entire system more then once to determine proper pulley positioning.

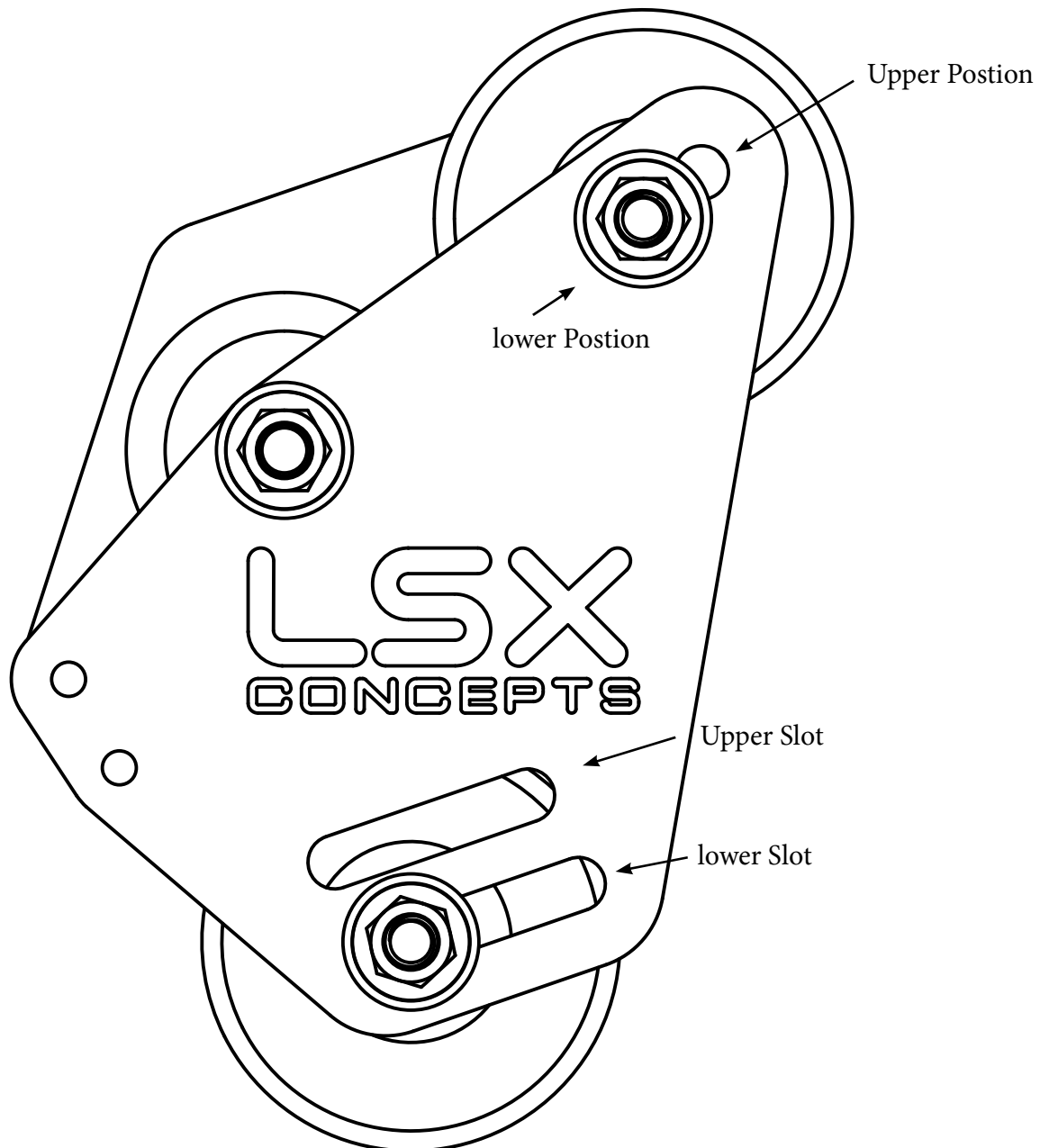

4: Rear Plate Pulley Bolts

Put the two 10MM Bolts (#6) with the two large steel washers (#7 & #8) through the back of the rear plate (#2) in the appropriate hole and slot for your combination, as shown.

It may be necessary for multiple test fitments to determine the correct pulley positions for you combination.

Note: Do not use the two small aluminium spacers here, they are for the 8 rib idler pulley

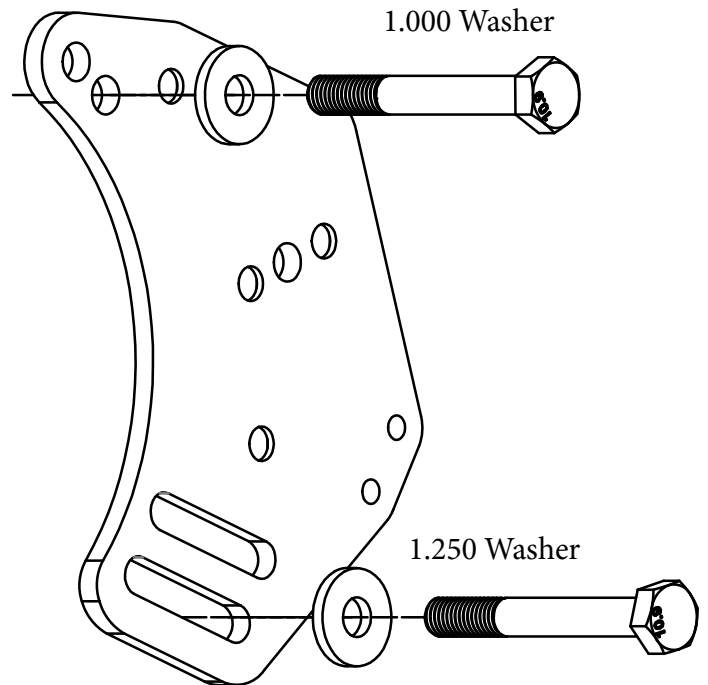

5: Rear Plate Installation

Install the three M8x55MM (#13) and one 8MMx20MM (#19) FHA through the rear plate into through the main LSA mounting block as shown and attach to the LSA water pump.

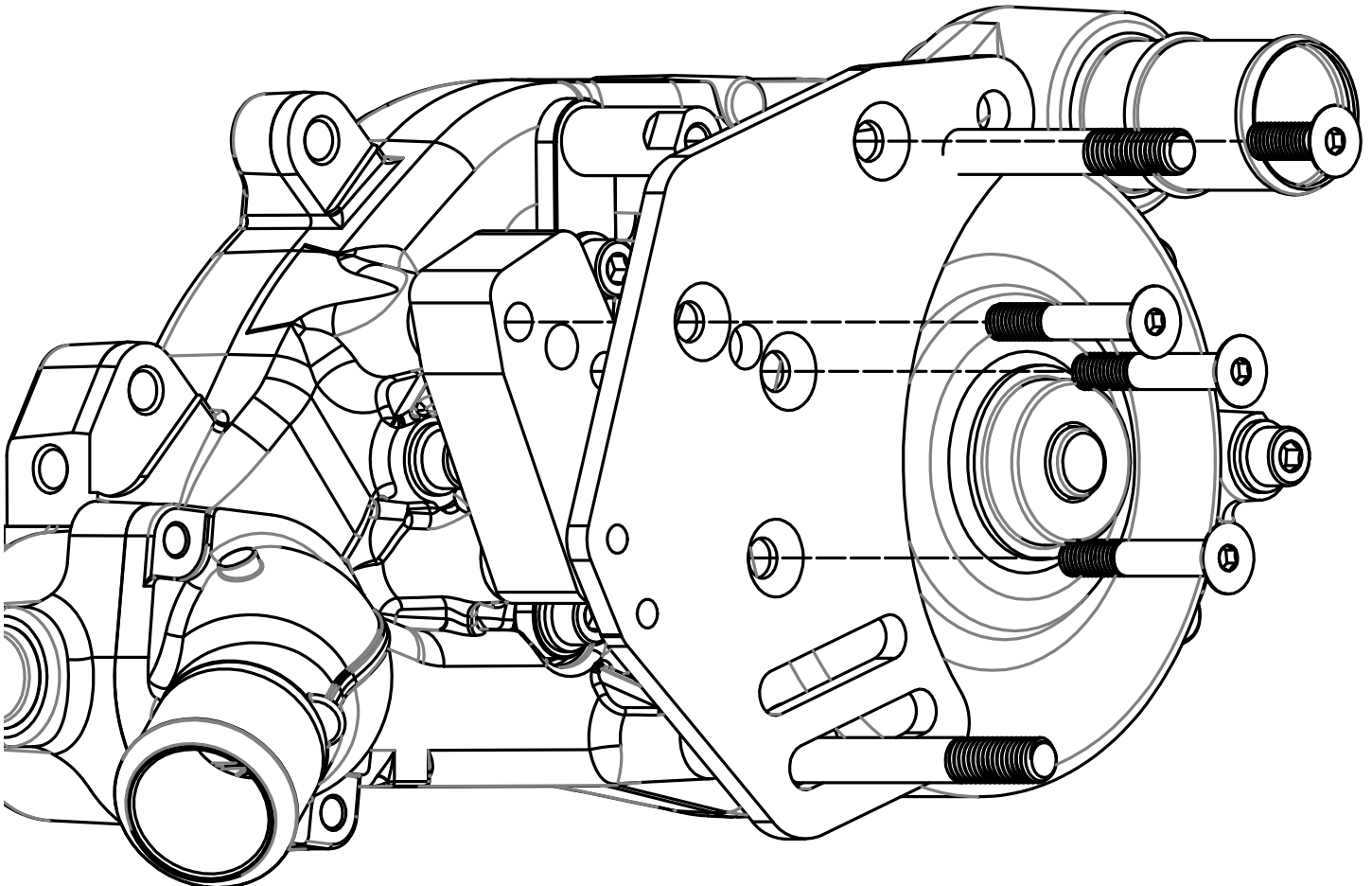

6: Rear Plate Instalation

Torque All the 8MM Flat head Allen Bolts to 20Nm (15 ft. lbs.)

7: Rear Plate Stud Installation

To install the 10MM Axle Stud (#9) into the mounting block, tighten two of the 10MM mock up flange nuts (#18) together as a driver, insert the stud into the threaded hole in the main LSA bracket mount block and tighten. There is a set screw in the base of the mounting block to provide a positive stop for the stud. When installed the stud should protrude about 2-3/4" from the rear plate

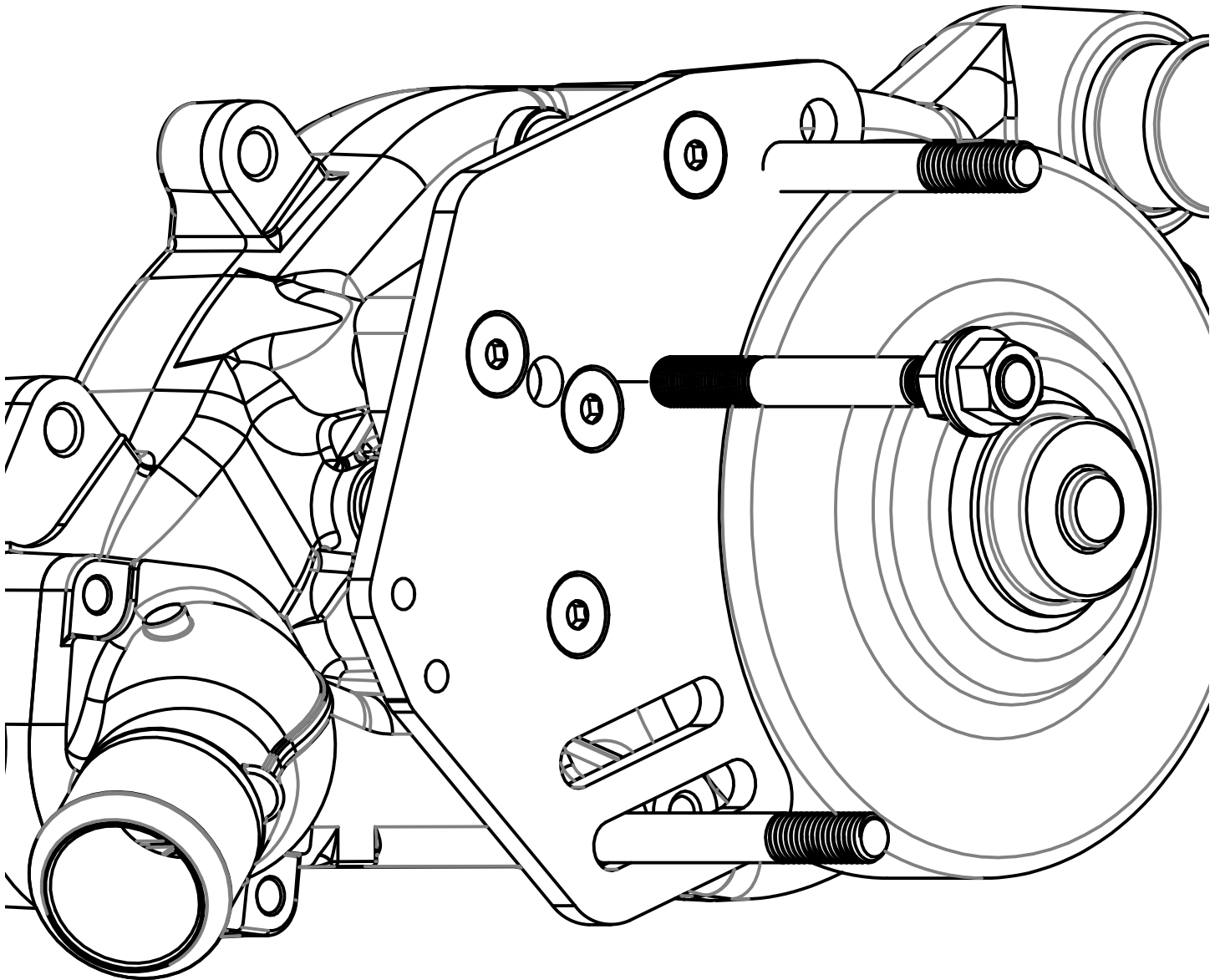

8: Pulley Installation

Install the 3 pulleys as shown using the appropriate spacers. The ribbed pulley uses the two flat aluminum spacers (#12) and the two idler pulleys use the aluminum stepped spacers (#11). (Note: the 3 chamfered washers are used outside the front plate when attaching the front cover).

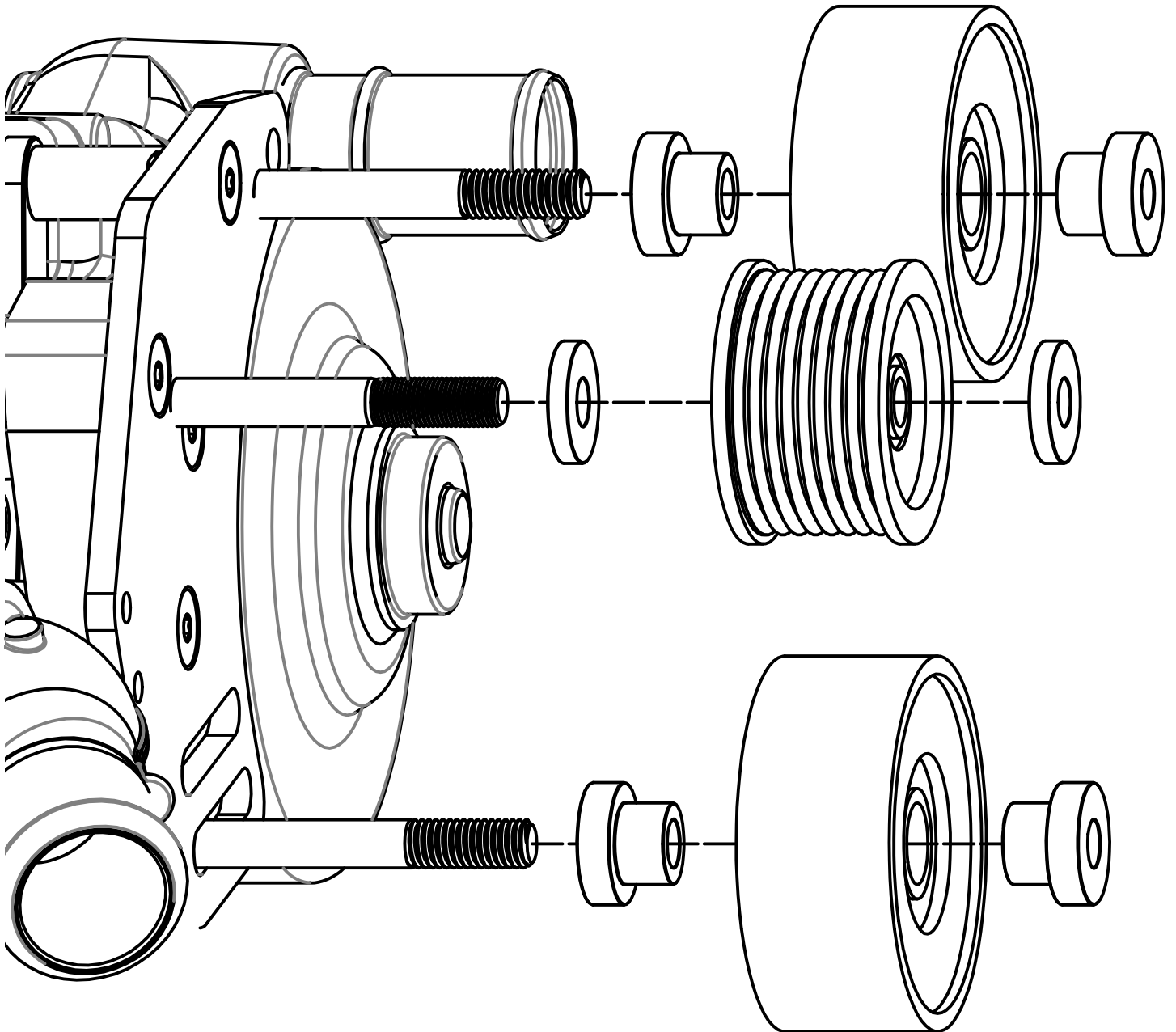

9: Belt Installation

Slide on the belt, route belt as shown and slide on the front cover (#1).

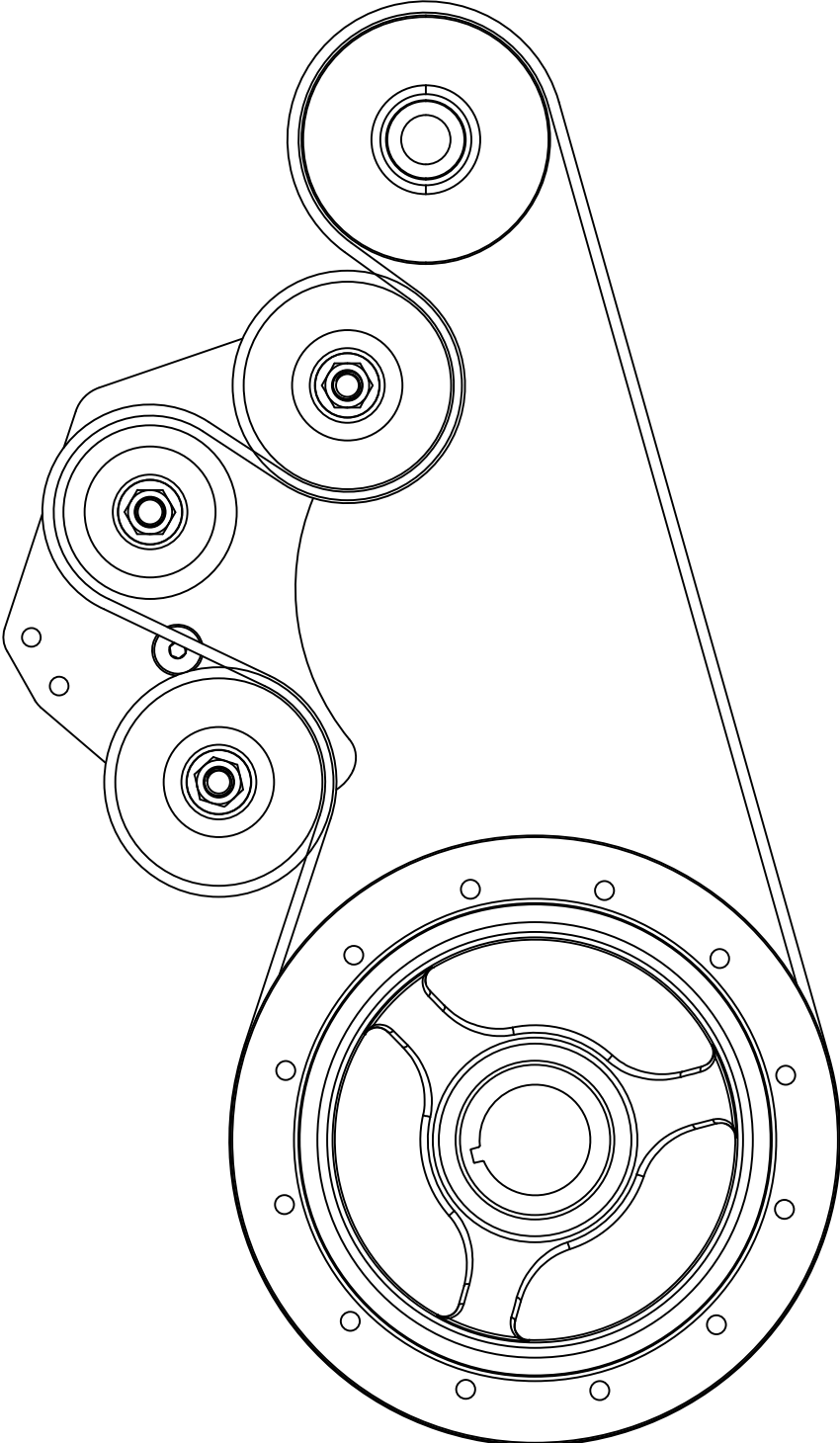

10: Front Cover Installation

Use the 3 chamfered aluminum washers (#10) on the studs. If the belt is too tight making it unable to line up the 3 bolts in the bolt holes on the front plate, leave the belt partial off on the crank pulley on the driver side. After bolting on the front plate use a wrench to rotate the engine over and carefully feed the belt onto the lower pulley.

For test fitting, and for initial belt measuring use the 3 black oxide flange nuts (#18) to hold the assembly together, for final assembly use only the nylon insert lock nuts.

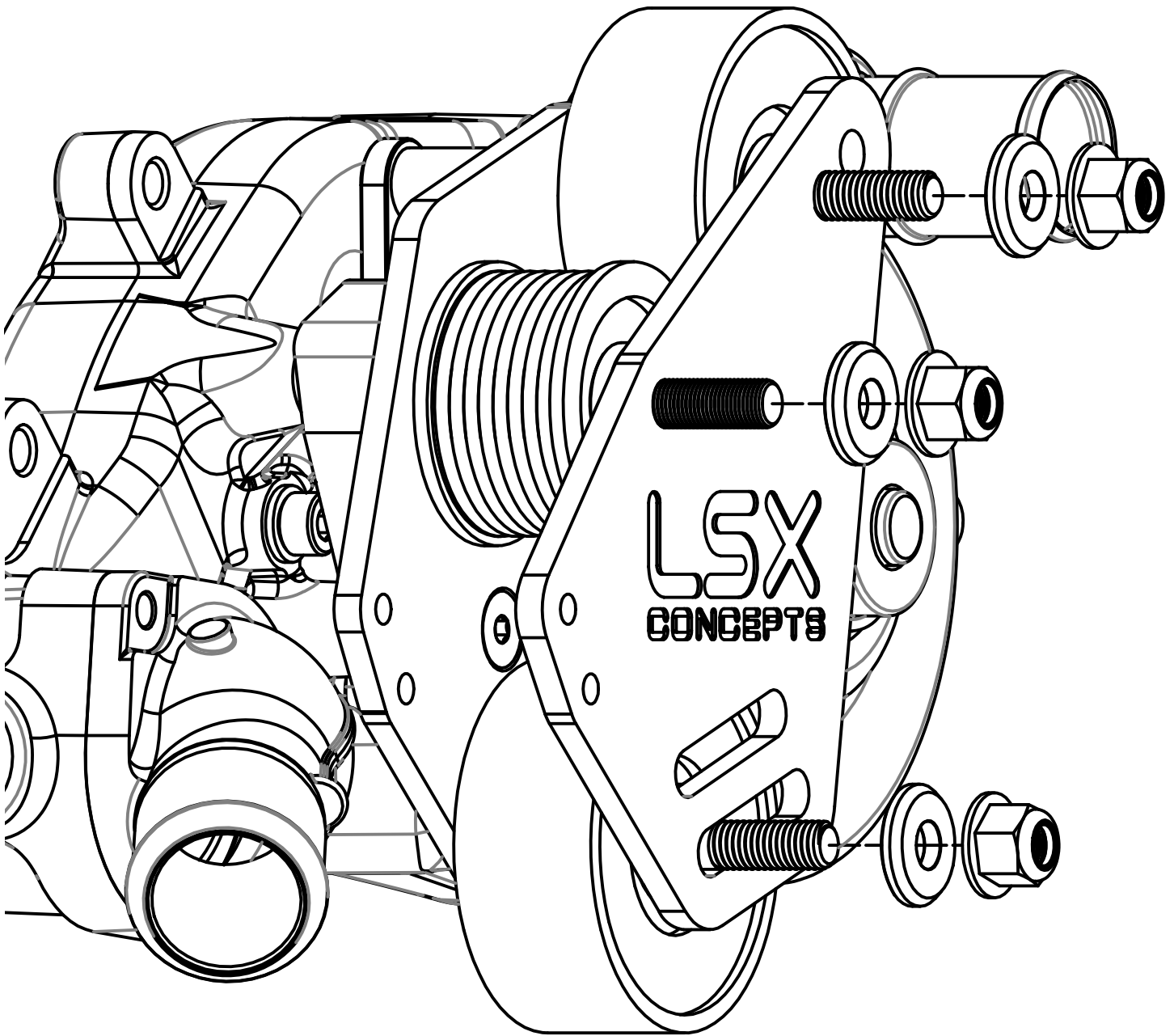

11: Belt Tightening and Break In

Align the torque arm (#21) pivot to the 1/4 hole in the front and rear plate. Slide in the 1/4 pin (#21). Use upper hole for adjusting the pulley if mounted in upper slot. Use the lower pin hole for adjusting the pulley if mounted in the lower slot. Set your torque wrench to 100 ft. lbs. and Insert it into 1/2 drive in the torque arm. Make sure your torque wrench is parallel to the torque arm. (see the picture below).

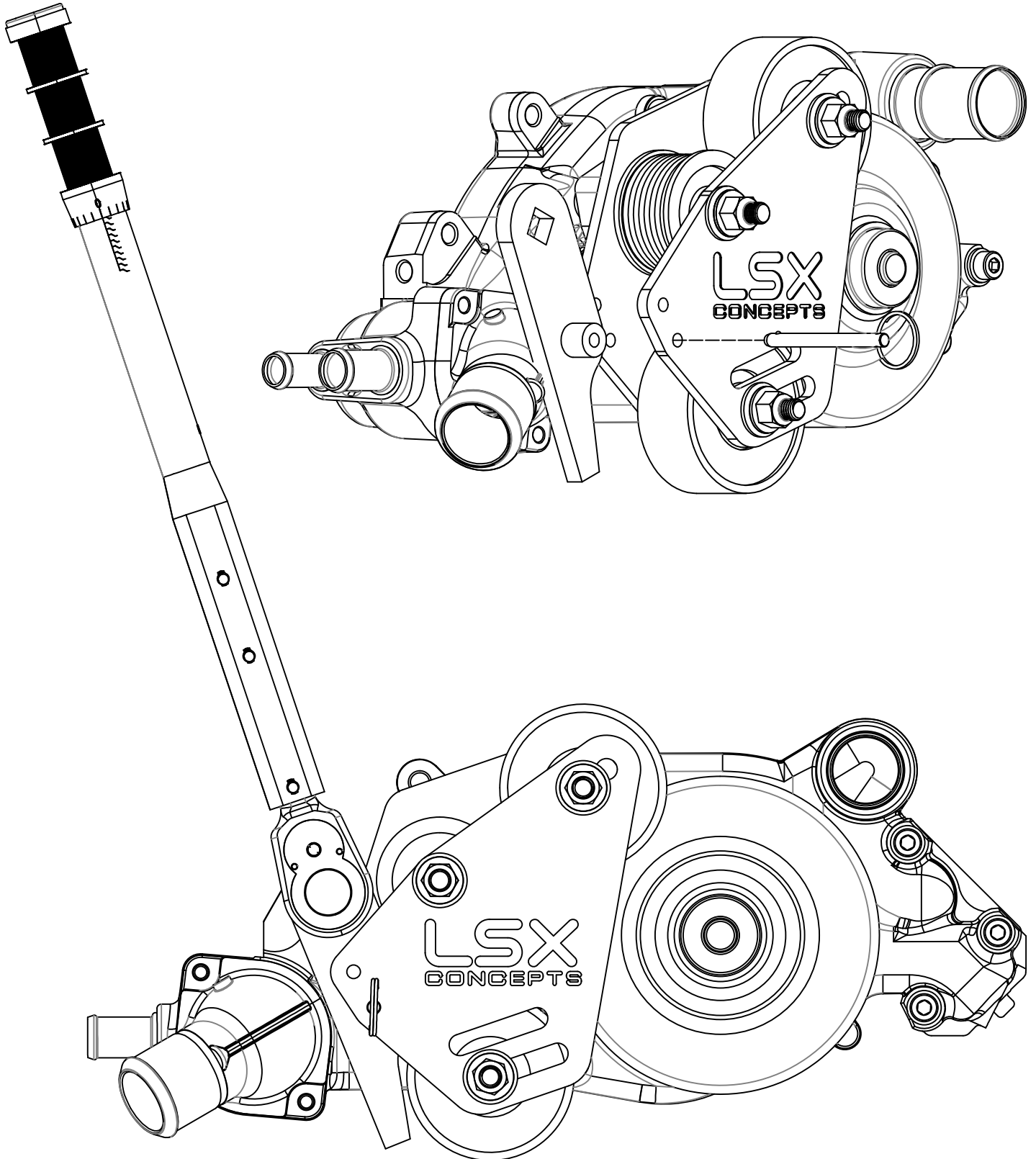

Serpentine Belts:

We recommend the use of **Continental Elite** belts whenever possible, the use of any other brand/ style of belts may result in premature loss of tension due to belt stretching, excessive belt wear, excessive black dust in the engine compartment. Please see the last page of the instructions for a list of available belt sizes and part numbers.

Maintenance and Break In:

The LSA Race Drive will require a serpentine belt break in procedure as show in the instructions any time a new 8 rib belt is installed, The belt tension and wear will need to be monitored and adjusted as needed.

Slide a open end 17MM wrench to the backside of the lower bolt. You will have to twist the 6 rib belt slightly to get to the bolt head on the backside of the rear plate. The belt will actually help hold the wrench in place for tightening the lower adjustable pulley.

The belt tightening procedure in the next step requires 2 people. One to operate the torque wrench and the other to loosen and tighten the bolts. You must maintain torque on the torque wrench while loosening and tightening the pulley bolt. Do not allow tension to slacken during the multi step tightening procedure. You will use this same procedure anytime you re-tighten or replace the belt.

After pulling the torque up to 100 ft. lbs. on the torque wrench, tighten the lower bolt. Then spin the engine over to distribute the belt stretch evenly across the entire belt length. You can do this by bumping the starter or putting a socket on the crank and turning the engine over by hand.

After you have turned the engine over about one turn, pull the torque back up to 100 ft. lbs. on the torque arm. While holding torque, loosen and re-tighten the lower pulley nut. DO NOT let the tension on the lower pulley loosen up. This is done because the belt does not stretch where it is in contact with the pulleys. It may take multiple times to distribute the load evenly on the belt to reach the desired belt tension as recommended by the belt manufacturer.

Check the belt tension using the provided Dayco gauge. It should be in the 260-280 ft. lbs. range on the tension gauge. If it is not, Repeat the tightening procedure (tighten, spin engine over, re-tighten) until it is the 260-280 ft. lbs. range is achieved. This is the recommended setting from Dayco on a new 8 rib belt without an automatic tensioner. Once you have achieved the desired tension pull the 1/4 pin out and remove the tensioner adjustment arm.

Belt Break In

New Belt Tension: 280 lbs. (GATES HD BELTS @ 175)

Retention Amount (After 3-5 Min run In): 240 lbs. (GATES HD BELTS @ 125-175)

***Used Belt Tension:** 120 lbs

*The used belt tension is the amount of tension that would typically be maintained under normal drive conditions by the given belt size. If the tension drops below the used belt tension, then the belt should be re-tensioned according to the RETENSION amount. If the belt is shown to be worn, either caused by excessive slipping or just normal long term operation, then the belt should be REPLACED rather than retensioned.

12: Belt Selection

Once you have trial fitted your LSA Race drive, it is important to measure and select the right length belt. Since so many combinations are possible we recommend measuring your setup and have provided you with a tape measure to properly measure for your belt. Route the tape measure and get the measurement. Take the value and multiply by 1.008 (adjusts for belt thickness)

Sample Measurements (all the following samples are using a std deck block) show for comparison.

Stock Upper Pulley and Lower Pulley : 51-3/4 (51.750*1.008 = 52.164) Use Belt 52.5" PN #4080525

Stock Upper Pulley and Lower 5% Pulley : 52-3/4 (52.750*1.008 = 53.172) Use Belt 53.5" PN #4080535

Stock Upper Pulley and Lower 10% Lower : 53-1/2 (53.5*1.008 = 53.192) Use Belt 54.5" PN #4080545

Stock Upper Pulley and Lower 22.5% Lower : 55-3/4 (55.750*1.008 = 56.196) Use Belt 56.5" PN #4080565

Belt length should always be about 1/2 larger than the measurement to allow easy instalation. Too long of a belt will work but will not allow as much belt stretch and will require belt replacement sooner then a proper sized belt.

See Page 12 for belt part numbers by length.

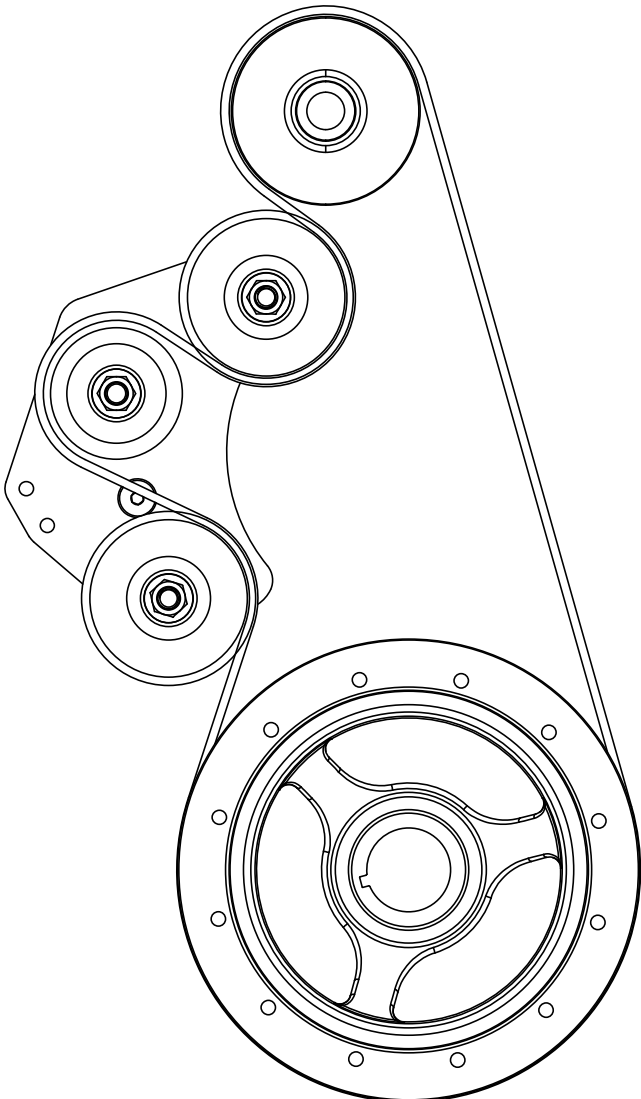

Dayco Tension Gauge Demonstration Video

Scan QR Code Below to View

<https://www.lsxconcepts.com/pages/dayco-krik-it-tension-gauge>



LSX Concepts Recommends Continental Elite Belts whenever possible on your LSA Race Drive. For your convenience we have provided a list of available belts by length with the appropriate part number from multiple manufacturers

Measure for the belt length using the provided tape measure and multiply the length by 1.008 and find the closest matching belt size in the chart below. try and use the shortest belt possible because the belt will continue to stretch as it is used with the race drive.

Belts are available at Amazon.com, eBay.com and your local auto parts store

INCHES	MM	BANDO	DAYCO	GATES	GATES RPM	CONTINENTAL
51	1295	8PK1295	5080510	K080510		4080510
51.5	1320	8PK1320	5080515			4080515
52.4	1330	8PK1330				
52.5	1335	8PK1335	5080525	K080525	K080525RPM	4080525
53	1345	8PK1345	5080530	K080530	K080530RPM	4080530
53.7	1365	8PK1365	5080537	K080537	K080537RPM	4080537
54	1370			4080540		
54.3	1380	8PK1380				
54.5	1385	8PK1385	5080545	K080545	K080545RPM	4080545
55	1395	8PK1395	5080550	K080550	K080550RPM	4080550
55.5	1410	8PK1410	5080555			4080555
56	1420	8PK1420	5080560	K080560	K080560RPM	4080560
56.1	1425	8PK1425				4080562
56.5	1435	8PK1435	5080565	K080565		4080565
57	1445	8PK1445	5080570	K080570		4080570
57.3	1455	8PK1455				
57.5	1460	8PK1460	5080575	K080575		4080575
57.9	1470	8PK1470				
58	1475	8PK1475	5080580	K080580		4080580
58.3	1480	8PK1480				
58.5	1485	8PK1485	5080585	K080585		4080585
58.7	1490	8PK1490				
58.9	1495	8PK1495				
59	1500	8PK1500	5080590	K080590		4080590

Compatible LSA/ZL1 ACDelco Water Pump

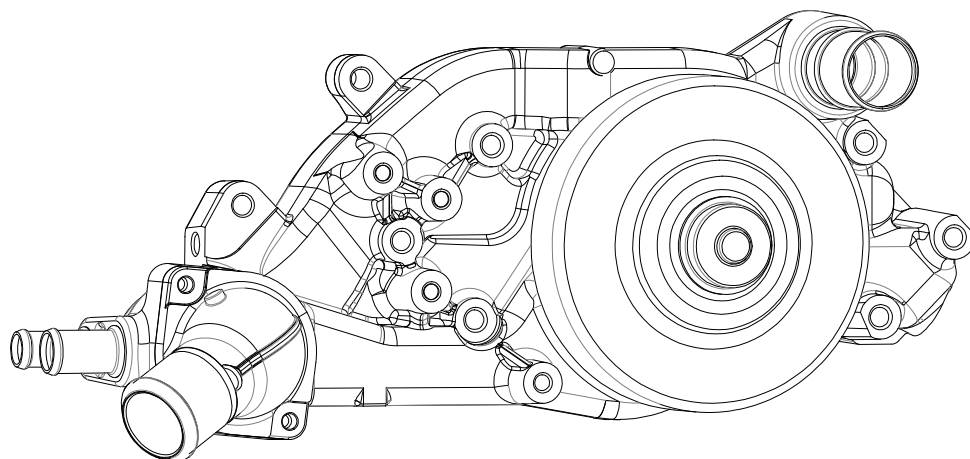

Compatible LSA/ZL1 Supercharger Accessories

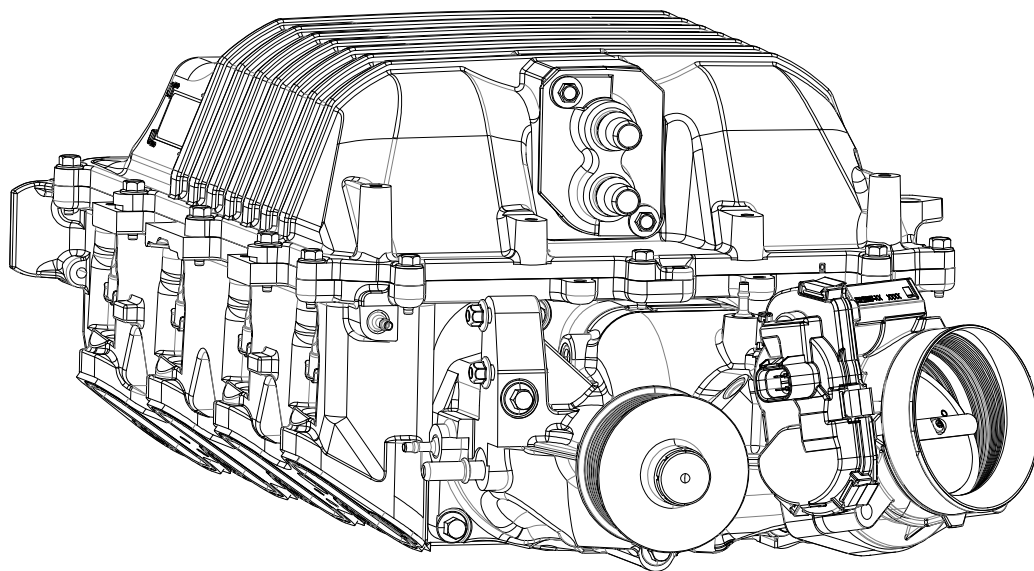

LSX Blog Articles



LSX Concepts Instagram



Tag your build photos

#lsxconcepts
#lsaswap
#lsaracedrive