

LSX Concepts

LSA Flex Drive High Mount Accessory Drive System (ALT,PS,A/C) (Direct Drive)

Remove - Water Pump (for A/C Kit installation)

Install – Alternator/Power Steering Kit as per Instructions

Alternator – Connect to your harness as per your wiring harness instructions

Install – High Mount A/C bracket as per instructions

Install – Water Pump with LSA Flex Drive standoff (step 2 of LSA Flex drive instructions)

Note: The stainless water pump bolts included with your kit only has 4 of the M8x75MM bolts and 2 M8x80MM bolts are included in the Race Drive kit with the standoff bracket as per step 2 of the Flex Drive instructions to install your water pump

Install – 6 Rib main accessory drive belt

Install – LSA Flex Drive as per instructions

If you have any questions or issues installing your kit, please feel free to call us and we will be happy to sort out any issues you're having with the install

LSX Concepts - 844-579-7927



INSTALLATION AND PROCEDURE FOR BLEEDING AIR FROM POWER STEERING SYSTEMS

CAREFULLY READ THESE INSTRUCTIONS BEFORE ATTEMPTING ANY MODIFICATIONS!

Proper bleeding of the power steering pump is the responsibility of the installer. Improper modification or installation will void your warranty and may result in vehicle damage or personal injury. If you have any installation questions, refer to your factory shop manual or call our Tech Service personnel at 216-961-1800 from 7am to 4pm EDT.

INSTALLING POWER STEERING PUMP

We recommend you follow Original Equipment Manufacturers Remove & Replace procedure for your specific Year, Make and Model Vehicle. Follow factory torque specifications and pressure recommendations.

BEFORE BLEEDING

Verify that the power steering hoses do not touch any part of the vehicle and that there are no leaks or loose connections. When filling the power steering pump reservoir, use only new, name brand premium quality power steering pump fluid. Do not use transmission fluid.

BLEEDING PROCEDURE

- 1 - Do not start the engine until the power steering system is fully bled.
- 2 - Raise the front end of the vehicle so that the front wheels are free to turn left and right.
- 3 - Turn the steering wheel fully to the left.
- 4 - Fill the power steering pump reservoir to full cold level. Leave the cap off the reservoir.
- 5 - With an assistant watching the fluid level, turn the steering wheel slowly and smoothly from lock to lock until the fluid level drops in the reservoir. Once the fluid level drops, have your assistant refill the reservoir to full cold level.
- 6 - If the fluid level does not drop in the reservoir after a few lock to lock cycles, there is still air in the system. On systems with an oil cooler, you may need to turn the steering wheel slowly and smoothly from lock to lock 20 to 40 times.
- 7 - After the reservoir fluid level drops and the reservoir is refilled, turn the steering wheel slowly and smoothly from lock to lock and verify that there are no bubbles or fluid level drops.
- 8 - Disable the engine from starting, then crank the engine for a few seconds. If the reservoir fluid drops, there is air trapped in the system. Continue above steps until the fluid in the reservoir remains constant and no air bubbles are seen.
- 9 - Lower the front wheels to the ground, start the engine and verify that the power steering fluid is at the correct level. Add fluid if necessary then reinstall reservoir cap. With the engine running, turn the steering wheel lock to lock and verify that the power steering assist is working properly, that there are no system leaks and that the reservoir is at the proper level.

NOTE

The power steering fluid level should not rise in the reservoir when the engine is turned off. If the fluid level rises, there is still air trapped in the system. Repeat the above bleeding procedure. Bubbles in the reservoir indicate a loose hose connection, a bad O-ring or a bad hose end/flare seat. A properly working power steering system has no air bubbles.

LSX Concepts - LSA / ZL1 Supercharger Bolt Kit

www.lsxconcepts.com

Parts List

Qty	Desc.
5	M6x16mm (Fuel Rail)
17	M6x25mm (LSA Lid)
2	M6x25mm (Inter-Cooler Face Plate)
2	M6x30mm (Map Sensors)
2	M6x25MM (Sensors on Snout)
4	M6x40MM (Throttle Body)
32	M6 Washers

- Remove the seventeen (17) bolts from the supercharger cover. Refer to the bolt locations chart. Carefully remove the bolts, leaving the plastic Isolators in the bolt holes. The factory bolt Isolators must be re-used.
- Using hex drive socket torque each bolt down on the first pass to 44 in-lbs (5 Nm) then on a final pass of 89 in-lbs (10 Nm). Make certain to use the order shown below.
- Torque all other bolts down to 89 in-lbs (10 Nm). (Map Sensors, Intercooler Face Plate, Fuel Rail)

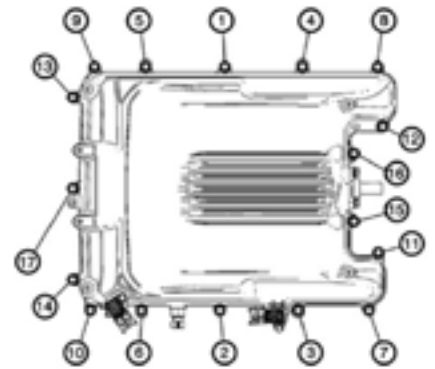

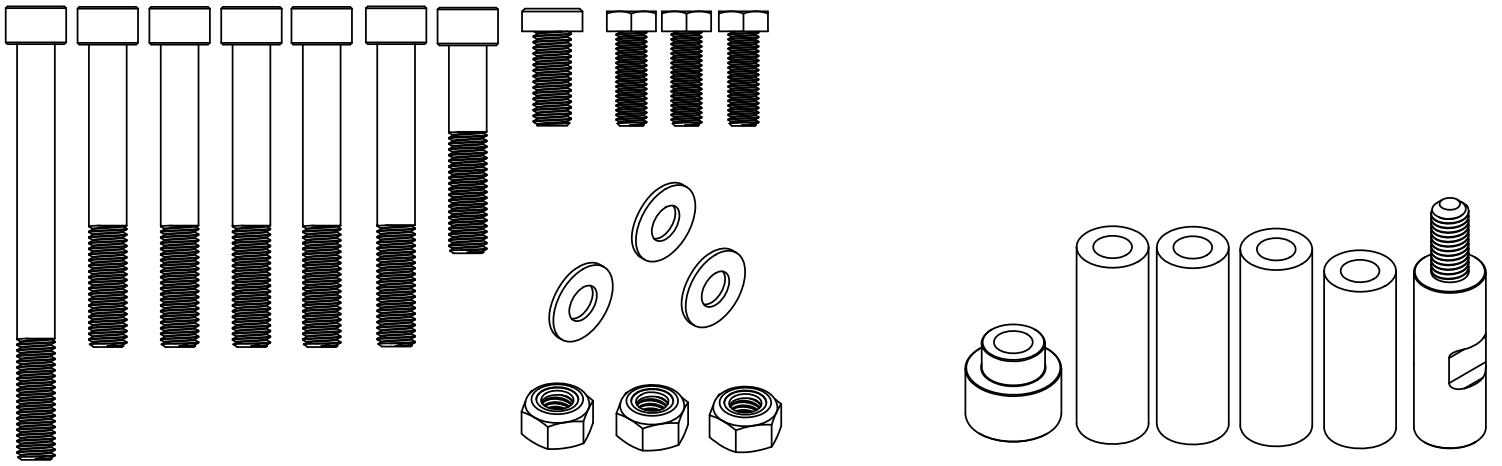

QTY.	BOLTS
1	10MM x 110MM SHA
5	10MM x 80MM SHA
1	10MM x 55MM Socket Head Allen
1	10MM x 25MM Low head Allen
3	8MM x 25MM Hex Head Bolt
3	10MM Nylon Insert Lock Nuts
3	10MM x .875" x .125" Washer

QTY.	SPACERS
1	1" x .600 Stepped Idler Spacer
3	3/4" x 2.299" Spacer
1	3/4" x 2.000" Spacer
1	3/4" x 2.000" Threaded Spacer

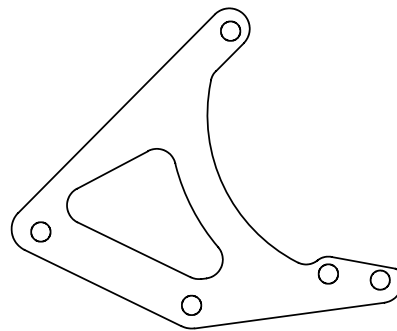
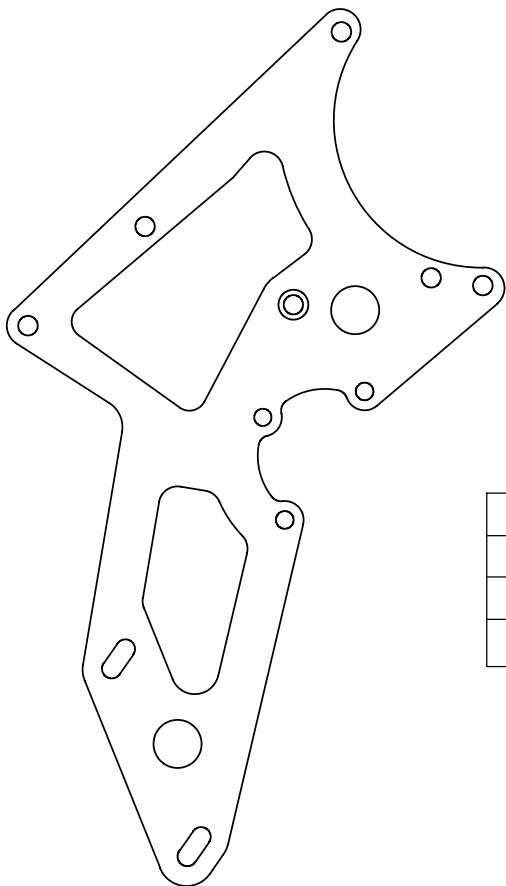

QTY.	PARTS
1	Front Bracket
1	Rear Bracket
1	60MM Smooth Idler Pulley

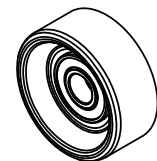

Installation Notes:

- do not torque bolts until all parts are installed
- some early LS1 blocks have only 1 mounting boss on the block, hardware is provided to mount the idler pulley if your block does not have both mounting bosses (see steps #2 and #3)

1: Attach the front and rear plate to the engine as shown

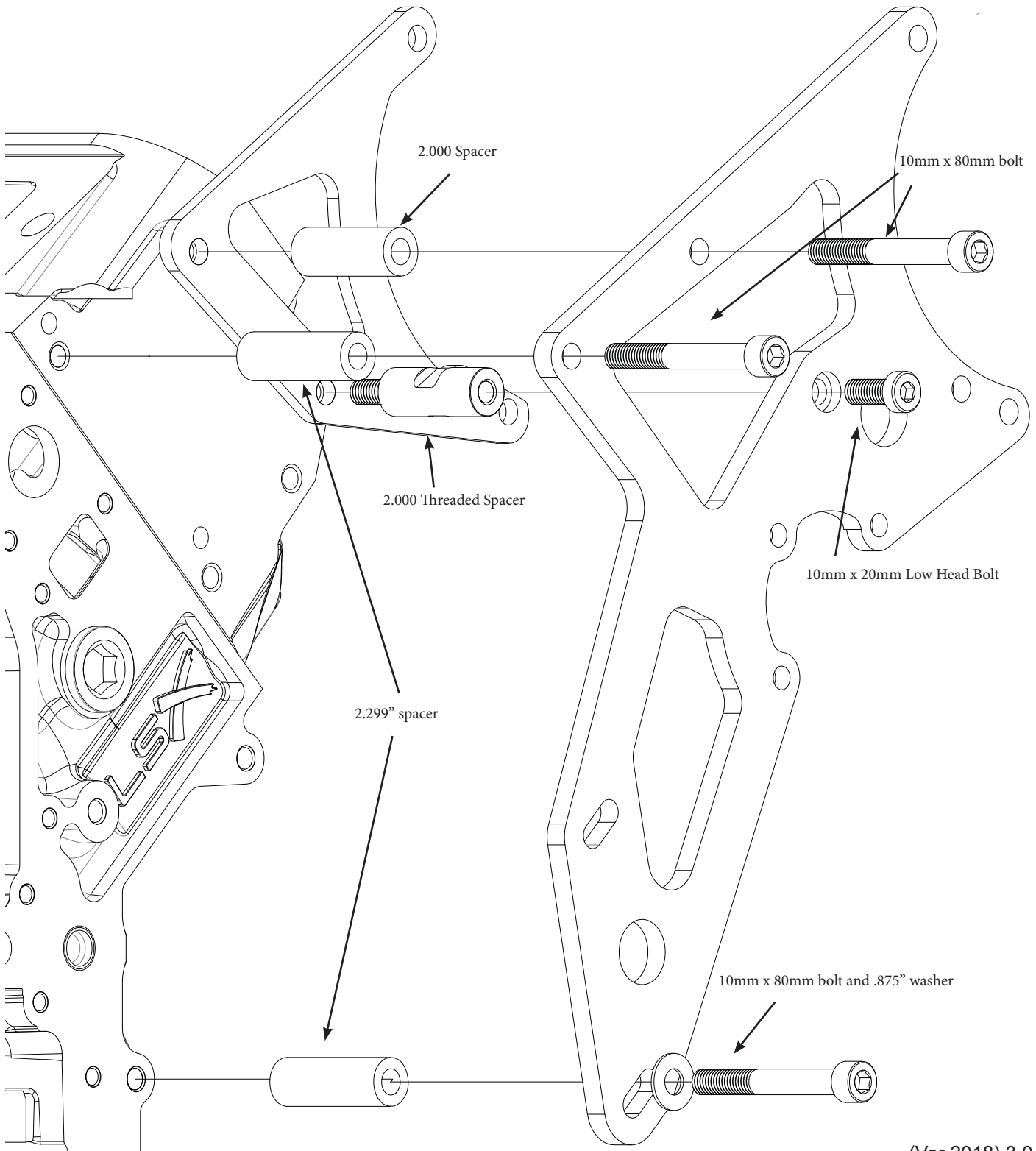

2: If your block has the upper mounting boss as shown the picture, mount the idler pulley using method 1, If your block does not have the mounting boss use method 2 for mounting your idler pulley

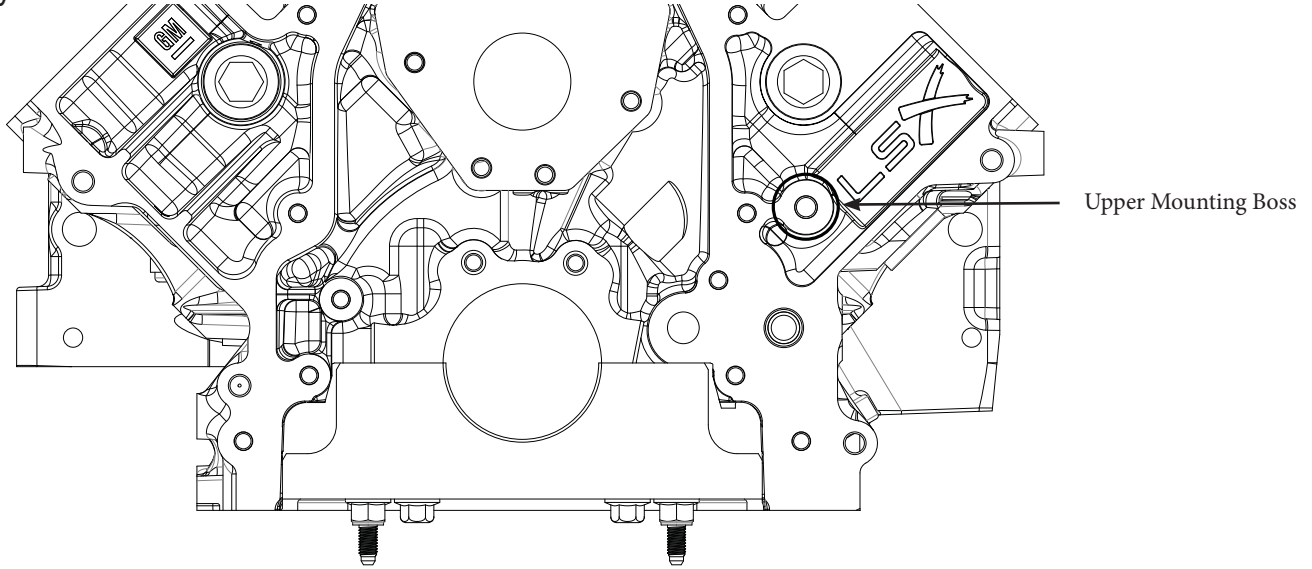

Method 1:

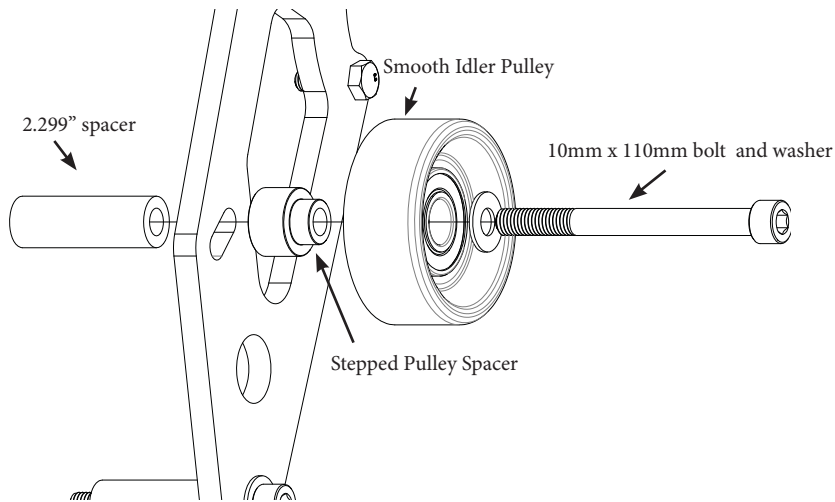

Method 2: Slide pulley/bolt towards the top of the slot

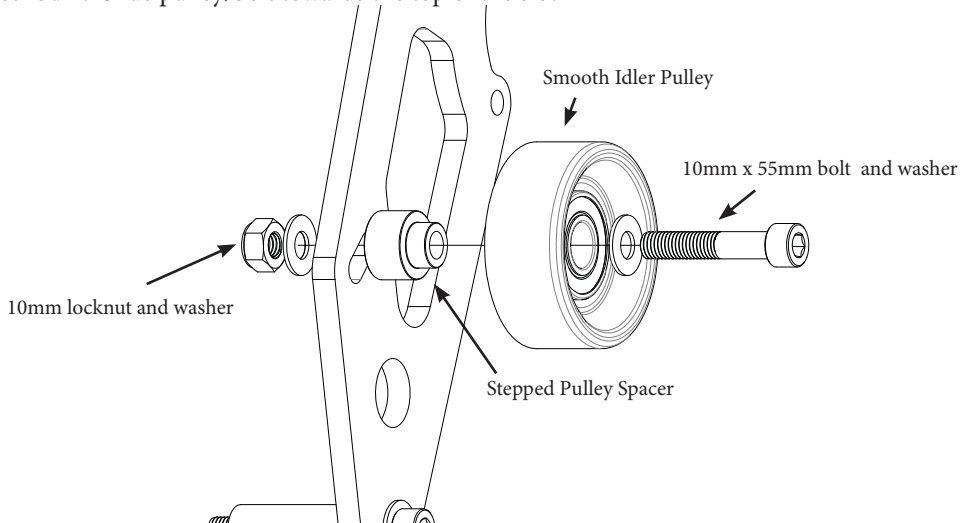

3: Attach the alternator

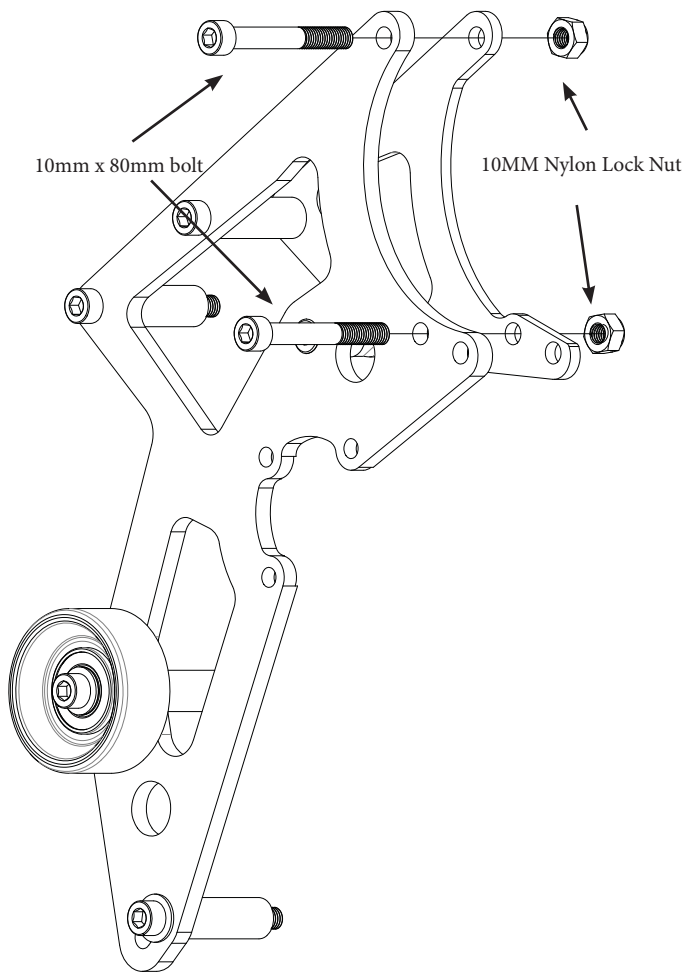

4: Attach the power steering pump

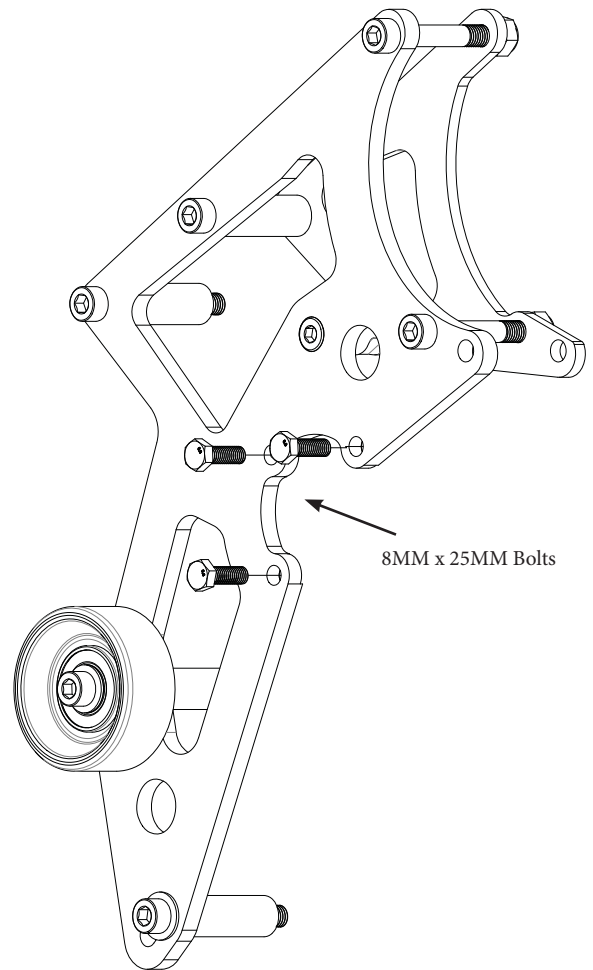

7: Torque Bolts

- torque all 10mm bolts to 25 ft-lbs (34 N-m)
- torque all 8mm bolts to 15 ft-lbs (20 N-m)

We do recommend using blue loctite 242 on all bolts threaded into the cylinder heads and block

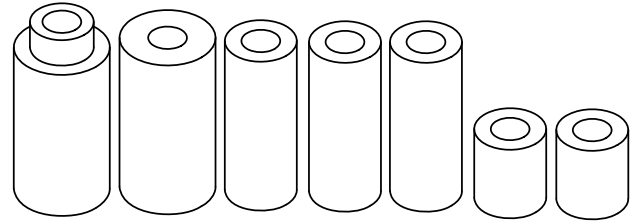
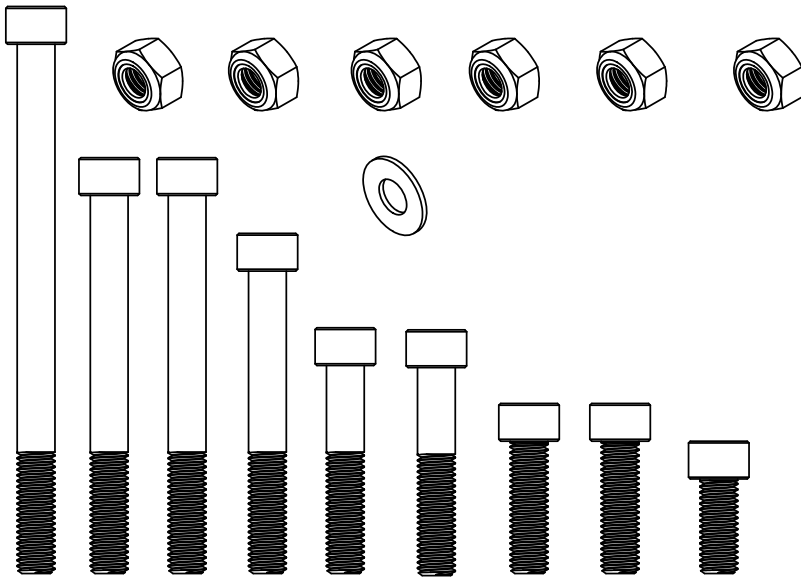

QTY.	SPACERS
1	1" x 1.850 Stepped Idler Spacer
1	1" x 1.900" Spacer
3	3/4" x 1.900" Spacer
2	3/4" x .875" Spacer

QTY.	BOLTS
1	10MM X 140MM SHA
2	10MM X 100MM SHA
1	10MM x 80MM SHA
2	10MM x 55MM SHA
2	10MM x 35MM SHA
1	10MM X 25MM SHA
6	10MM Nylon Insert Lock Nuts
1	10MM x 1" x .125" Washer (black oxide)

QTY.	PARTS
1	Front A/C Bracket
1	Rear A/C Bracket
1	A/C Idler Pulley

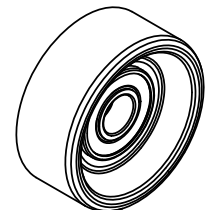
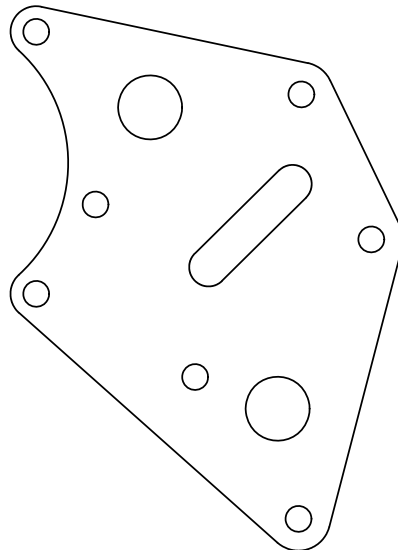
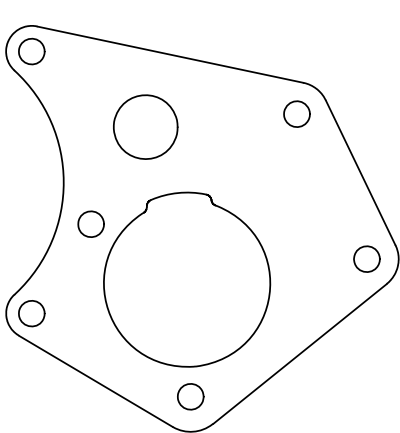

Tool/Supplies List

Loctite Threadlocker Blue 242

17mm socket/wrench

#8 Metric bit Socket / Allen Wrench

Installation Notes:

- Do not torque bolts until all parts are installed
- Water pump will need to be removed to gain access to the lower bracket bolt
- We recommend Applying blue 242 Loctite to any bolts threaded directly into the aluminum cylinder head, it is not needed on any bolts secured with a lock nut

ZL1/LSA Notes:

If this is a LSA/LZ1 Engine, please carefully unhook and remove the bypass solenoid and bracket as seen in the diagram to the right. the stock location interferes with the A/C idler pulley location. we recommend taking pictures and noting the original hose routing for relocation.

*See our LSA / ZL1 Supercharger Accessory Drive kit instructions for alternate mounting locations

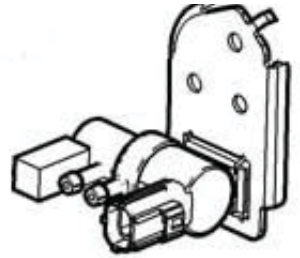

1: Remove the 6 rib pulley from the Corvette belt tensioner

2: bench assemble the front and rear bracket as shown, leave bolts loose

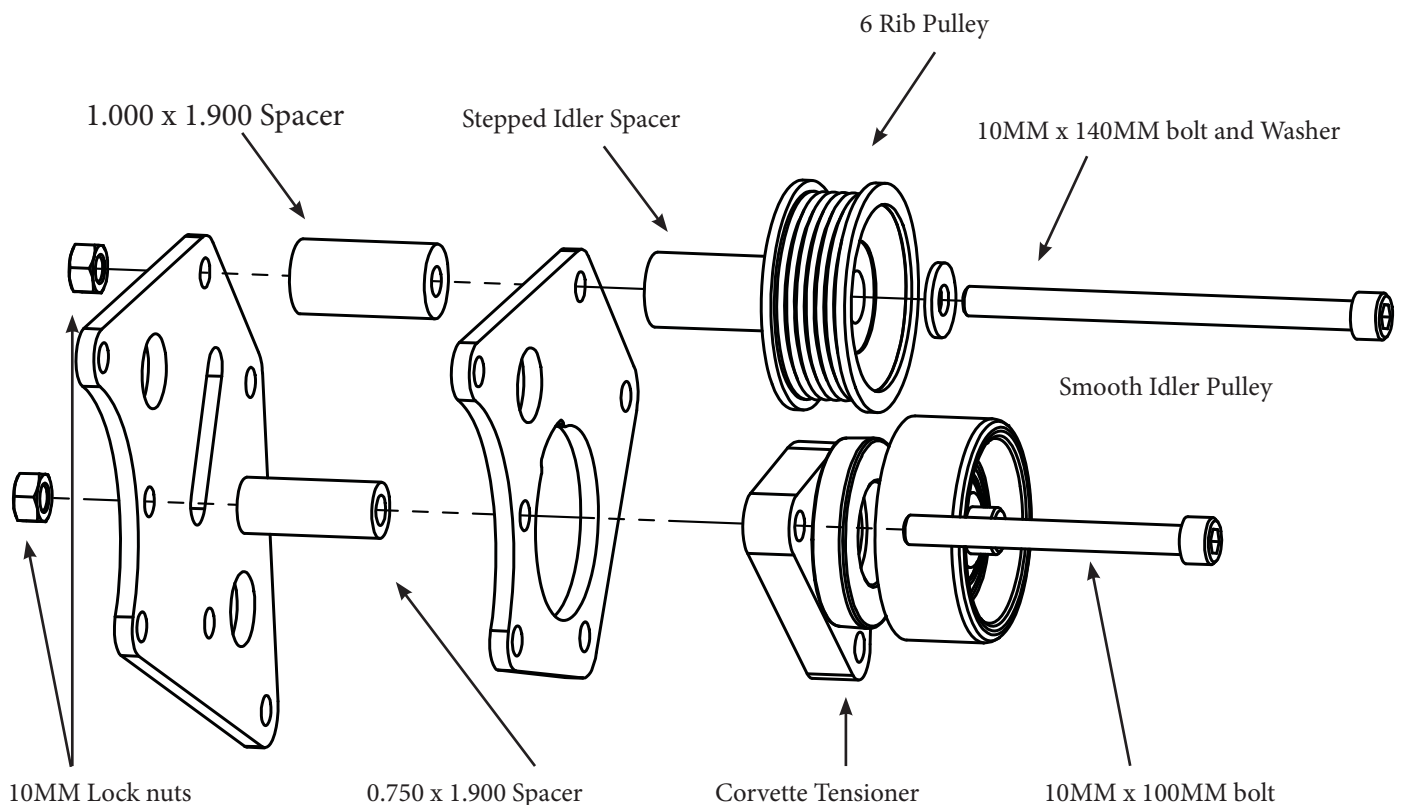

3: Attach the bracket assembly to the passenger side cylinder head

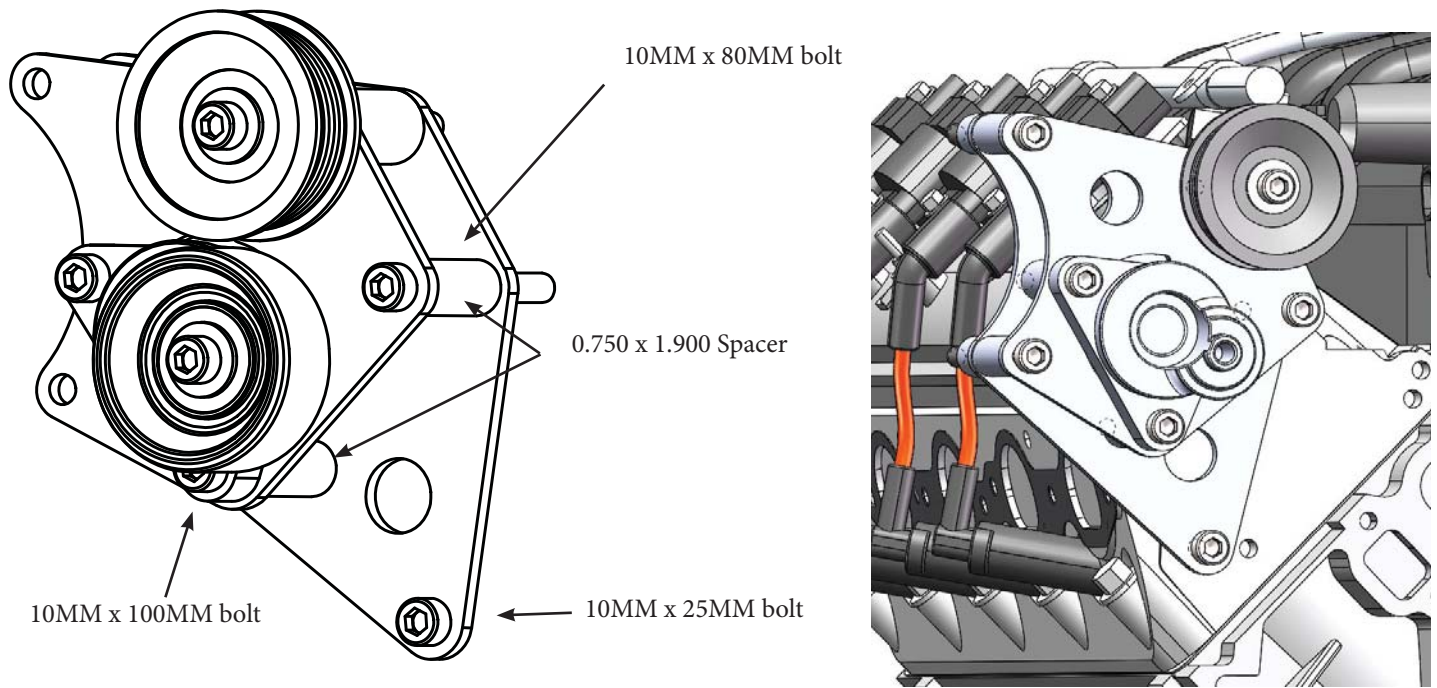

4: Attach the A/C compressor

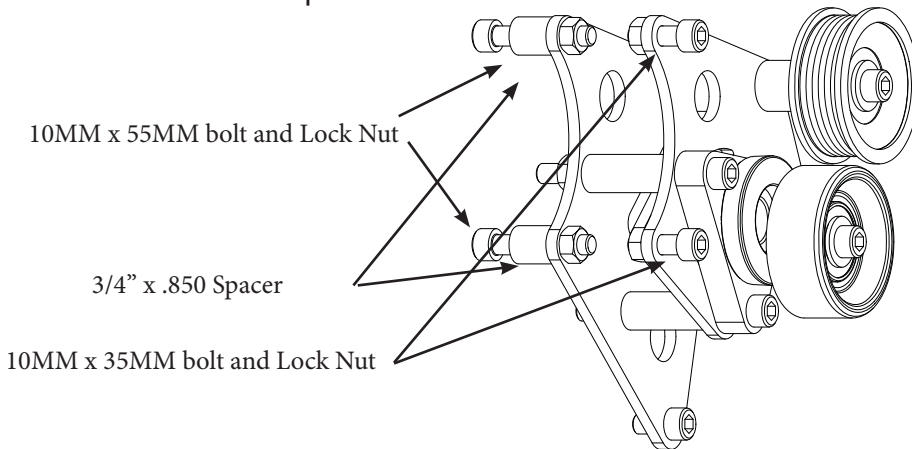

5: Torque all 10mm bolts to 25ft-lbs (34 N-m)

6: Install Serpentine Belt

Due to variations beyond our control some applications may require a shorter or longer belt. use a belt length that will put the belt tensioner indicator in the mid travel position as shown in the picture to the left.

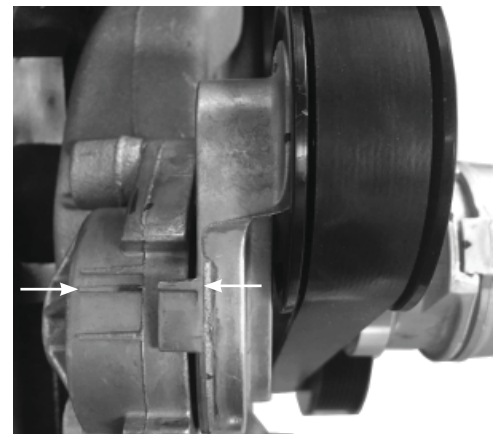

LSX Concepts - LSA Bypass Solenoid Placement

www.lsxconcepts.com

LSA Bypass Solenoid

Most overdriven boosted application and after-market ECM's do not use the bypass solenoid, however if you are running the bypass solenoid in your application it will need to be modified to clear the upper idler pulley on the High Mount A/C kit

Pictured below are a two examples.

NOTE: Both examples use 4MM tubing which can be purchased from Amazon for under 10.00

Example 1 : this example shows the stock bracket flipped and trimmed, using all the original hosing end with the factory tubing removed and repaced with Black 4mm x 2.5mm Pneumatic Polyurethane PU Air Hose Tube



Example 2: this example is the same orientation as the last example but this one is shown using custom bent Stainless Steel 304 Capillary Tubing 4mm OD

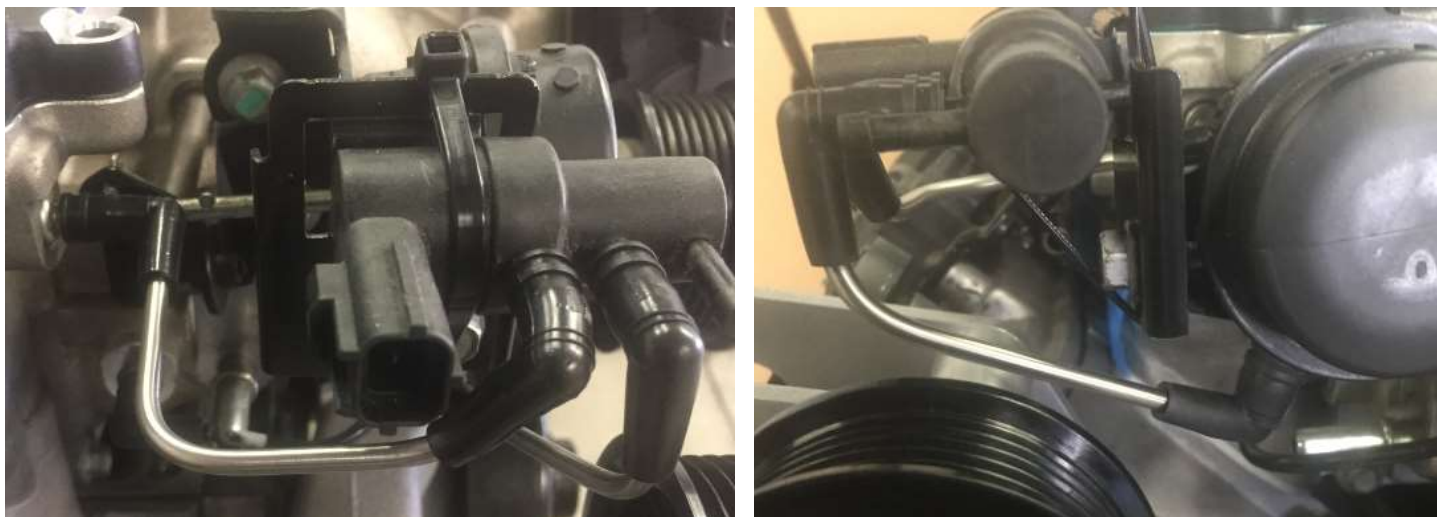

Instructions

1. MOUNTING TENSIONER

- a) Install the Tensioner Mount Bracket on the side of the Engine Block. Apply a small amount of Loctite to the threads and torque the (3) M10-1.5 x 35MM Socket Head Screws to 25 ft. lbs.

Note: The "Cloverleaf" Housing is factory installed on the Tensioner Mount Bracket and the four M6 screws are already torqued to specification.

- b) Place the "Cloverleaf" into its Housing with the #3 position to the left side. (as seen in the picture to the right)
- c) Install the Tensioner onto the Cloverleaf Housing. Lightly snug the retaining bolt
- d) Install the 10 Rib Tensioner Pulley and torque to 30ft. lbs. – **Note: The factory bolt is left-handed, please take care when installing and removing this bolt as they are not sold separately by GM**

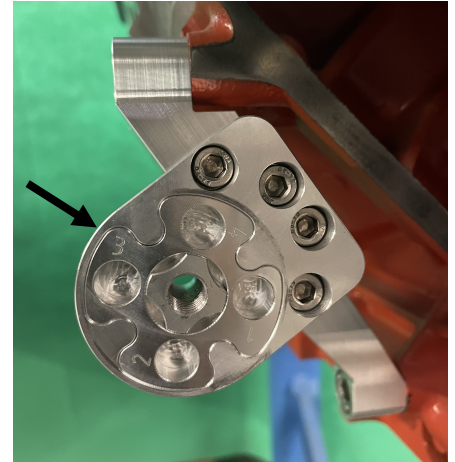

2. INSTALL SUPPORT ARM ONTO WATER PUMP

- a) If you are installing this kit with a High Mount A/C kit, install the A/C first
- b) Install the Support Arm onto the Water Pump. Use (2) M8 Hex Head Bolts and M8 washers as shown.

NOTE: Test the Support Arm and Spacer alignment to the Rear Bearing Support Plate. The Support Arm may need minor adjustment to line up with the upper hole in the Rear Bearing Support. There is enough clearance in the Support Arm mounting bolt holes to do so.

- c) Once the Support Arm is fitted, apply a small amount of blue Loctite, torque the bolts to 15 ft. lbs. NOTE: remove one bolt at a time to keep bracket lined up with the upper bolt hole on the Rear Bearing Support Plate.

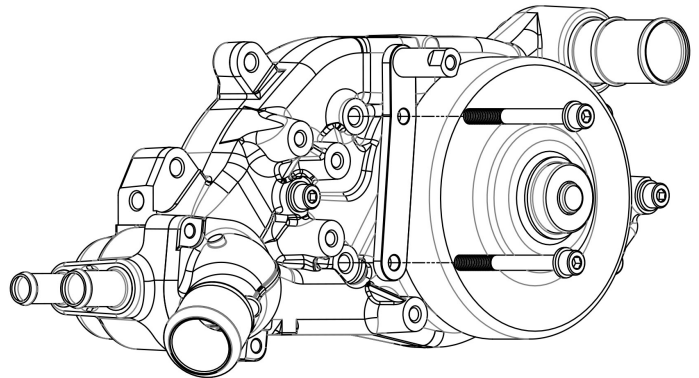

3. INSTALL REAR BEARING SUPPORT PLATE AND STUDS

- a) Bolt the Rear Bearing Support Plate to the Water Pump being sure all the holes line up. Then remove the bolts one at a time. Add a small amount of Blue Loctite and torque the (5) M8-1.25 bolts to 15 ft. lbs.
- b) Snug the upper right Pulley Mounting Stud into the Rear Bearing Support Plate. There are 2 positions marked E and F. Slip on the smooth Idler Pulley. Pick the closest location to the Blower pulley and still be able to easily install the belt between the Blower Pulley and the smooth Idler Pulley. Remove the Idler Pulley and Install the (1) Pulley Standoff Retention Nut. Apply a small amount of Anti-Seize to the threads and Torque to 20 ft. lbs.
- c) Snug the center left Pulley Mounting Stud into the Rear Bearing Support Plate. Install (1) Pulley Standoff Retention Nut. Apply a small amount of Anti-Seize to the threads and Torque to 20 ft. lbs.
- d) Snug the lower Pulley Mounting Stud into the Rear Bearing Support Plate. There are 4 positions. Start in position "B". Install the (1) Pulley Standoff Retention Nut. Apply a small amount of Anti-Seize to the threads and Torque to 20 ft. lbs.
- e) Install the Pulleys with snap rings facing outwards and install the outside (3) Pulley Standoff Retention Nuts. Apply a small amount of Anti-Seize to the threads and Torque to 20 ft. lbs.

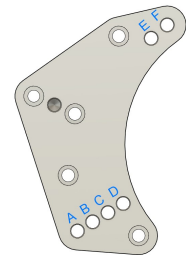
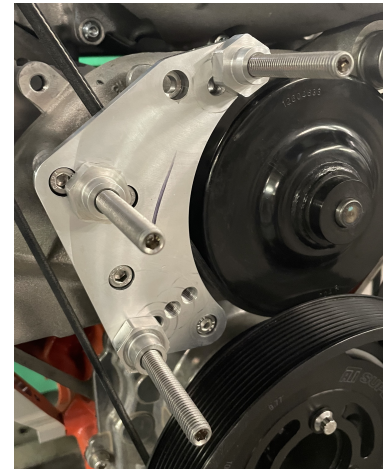

3. DISCOVER BELT LENGTH

- a) Simply wrap the Cloth Tailors Tape Measure (provided) following the belt path around the pulleys according to the picture. Your belt length should be ½ inch shorter than that measurement.
- b) Available belt lengths may vary, the catalog may skip the length you desire. Pick the one closest to your measurement. If you need assistance in finding the right belt, give us a call @ 844-579-7927 or email us at sales@lsxconcepts.com. The lower stud location can adjust for ½ inch longer or shorter belts, it's ½ inch belt length per hole position. Relocate the stud as necessary and re-torque the Pulley Standoff Retention Nut to 20 ft. lbs.
- c) To fit the belt requires two people, one to install the belt and one to inspect the tensioner. The tensioner gauge is located on the bottom side of the tensioner. We have found it helpful to pull the tensioner to its full tension mark and draw a line with a felt pen on the top of the housing for easy viewing.

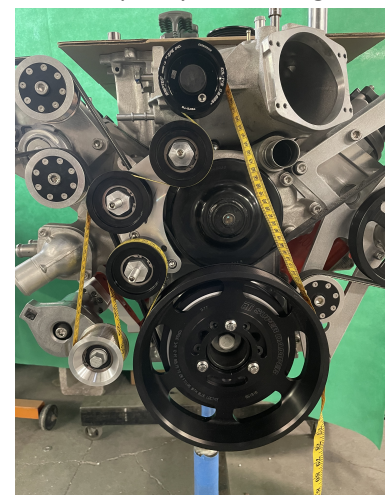

4. SYSTEM ADJUSTMENT VALUES

There are two belt adjustments, a coarse adjustment by changing stud location and fine adjustment by moving the cloverleaf location. The overall system allows for over 2 inches of belt length adjustment.

- a. The lower Pulley Stud location is worth about ½ inch in belt length. You may find that if the belt you have is longer or shorter than desired you may wish to alter the lower Pulley Stud location from the onset.
- b. Each number on the "Cloverleaf" is worth about 3/16 in belt length and about a .070 change on the Tensioner housing gauge. The lower the number being looser
- c. Each stud location is worth about 4 numbers on the "Cloverleaf" allowing some overlay for fine belt tuning without altering pulley stud location.

5. DISCOVER THE ACTUAL BELT TENSION

- a. While the Tensioner is UNLOADED slip the belt on being sure the serpentine side of the belt matches the pulley grooves.

NOTE: If the belt is too tight to install, remove the tensioner and place the "Cloverleaf" in the #1 position, then try to reinstall the belt again. If the belt is still too tight move the lower stud and pulley to the "A" position and the "Cloverleaf" back to #3 position and try again.

- b. Once the belt is installed, release the Tensioner, and view the gauge. Moving the "Cloverleaf" by one number alters the gauge by .070". If you reach the # 8 position on the "Cloverleaf" and the belt is still too loose, move the lower Pulley Stud to the "C" position and the "Cloverleaf" to #3 and try again. Torque the Tensioner retaining bolt to 20 ft. lbs.

6. INSTALL THE FRONT DOUBLE SHEER PLATE

- a. Recheck the Pulley Standoff Retention Nuts for being tight. Torque to 20 ft. lbs.
- b. Install the Front Plate. Install the (3) aluminum Washers and the (3) Nylon Lock Nuts. Torque to 25 ft. lbs.
- c. Torque the Tensioner retaining bolt to 20 ft. lbs.

7. FINAL ASSEMBLY - TORQUE VALUES

The (5) M6 Rear Plate mounting bolts - torque to 15 ft. lbs. (M6)

Loctite the (3) M10 Pulley Studs - Hand Tighten till snug, do not over tighten

Pulley Standoff Retention Nuts - torque to 20 ft. lbs. (use Anti-Seize on threads)

Front Cover Nylon Lock Nuts torque to 25 ft. lbs.

Tensioner retaining bolt to 25 ft. lbs. (M10)

8. Belts

A complete listing of belts by length can be found on the Summit Racing website (scan QR code to visit Summit Racings 10 rib belt collection)

<https://www.summitracing.com/search/part-type/accessory-belts?N=number-of-belt-ribs%3A10&SortBy=BestKeywordMatch&SortOrder=Ascending&keyword=serpentine%20belts>

If you are unable to find a suitable belt for your combination give us a call or email with your measurements and we will be happy to find you a belt to fit your combination

Known Combinations

For a list of known/proven belt combinations visit the website

<https://www.lsxconcepts.com/pages/instructions-billet-10-rib-lsa-supercharger-flex-drive>

