

LSX Concepts

LSA Flex Drive High Mount Accessory Drive System (ALT,A/C) (Direct Drive)

1. Remove - Water Pump (for A/C Kit installation)
2. Install – Alternator Kit as per Instructions
Alternator – Connect to your harness as per your wiring harness instructions
3. Install – High Mount A/C bracket as per instructions
4. Install – Water Pump with LSA Flex Drive standoff (step 2 of LSA Flex drive instructions)
5. Install – 6 Rib main accessory drive belt
6. Install – LSA Flex Drive as per instructions

If you have any questions or issues installing your kit, please feel free to call us and we will be happy to sort out any issues you're having with the install

LSX Concepts - 844-579-7927

LSX Concepts - High Mount Alternator Bracket (Corvette Belt Spacing)

Part Number # LSX-ALT-COR

www.lsxconcepts.com

Tool/Supplies List

Torque Wrench (ft-lbs)
Loctite Threadlocker Blue 242
8MM Allen Hex Socket
14MM Wrench

Installation Notes:

- Do not torque bolts until all parts are installed
- Apply Loctite to any bolts threaded into directly into the aluminum cylinder head, it is not needed on any bolts secured with a lock nut

1: Assemble as shown in the image below

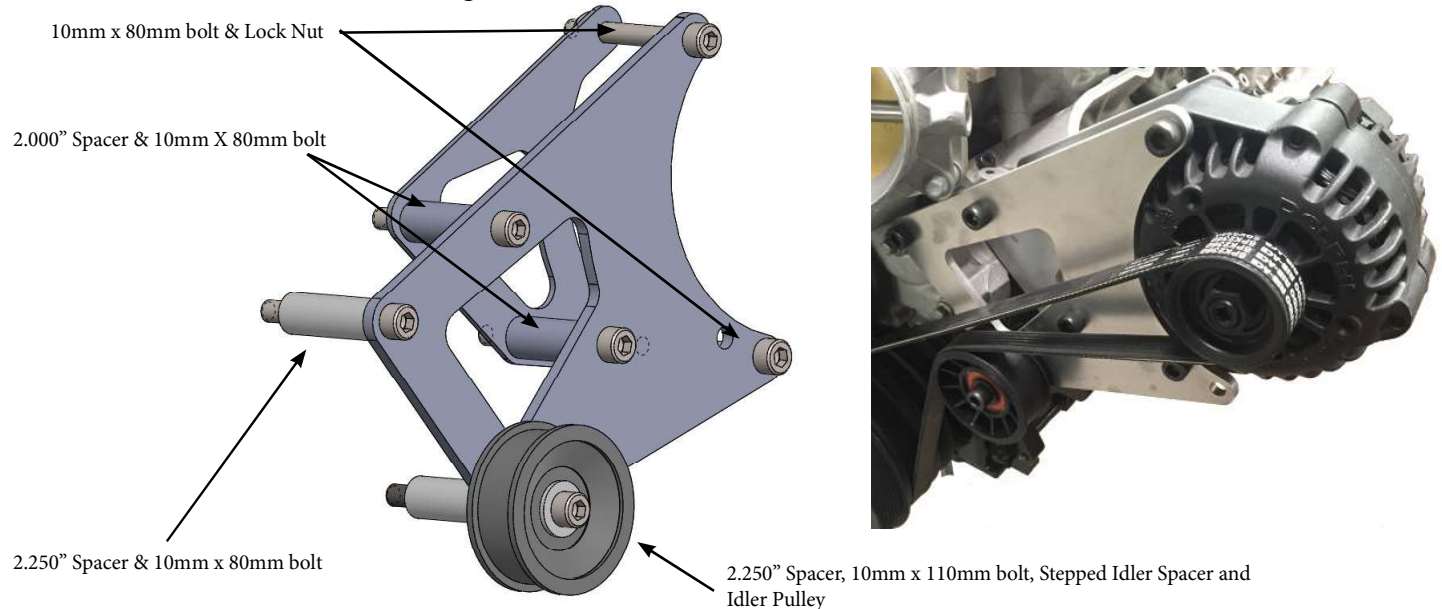

2: Torque all 10mm bolts to 25ft-lbs (34 N-m)

3: Install Serpentine Belt

- Standard deck block (9.240 deck height) with a 7.48 dia. damper, factory water pump, factory belt tensioner, Corvette alternator uses a 73" 6 rib serpentine belt

Due to variations beyond our control some applications may require a shorter or longer belt. use a belt length that will put the belt tensioner indicator in the mid travel position as shown in the picture to the left. (please see our belt measuring instructions if you need to measure for a belt)

Correct Tensioner Position



LSX Concepts - High Mount Alternator Bracket (Corvette Belt Spacing)

Part Number # LSX-ALT-COR

www.lsxconcepts.com

- Alternator bolt pattern Compatibility shown below

Two bolts patterns supported the 5.455 bolt pattern is found on GM Cars/trucks and Pickups with high mount alternators from the factory. Not compatible with common low mount alternators.

The 6.062 bolt pattern is commonly found on Corvettes (Alternators are commonly referred to as the Valeo Series alternator)

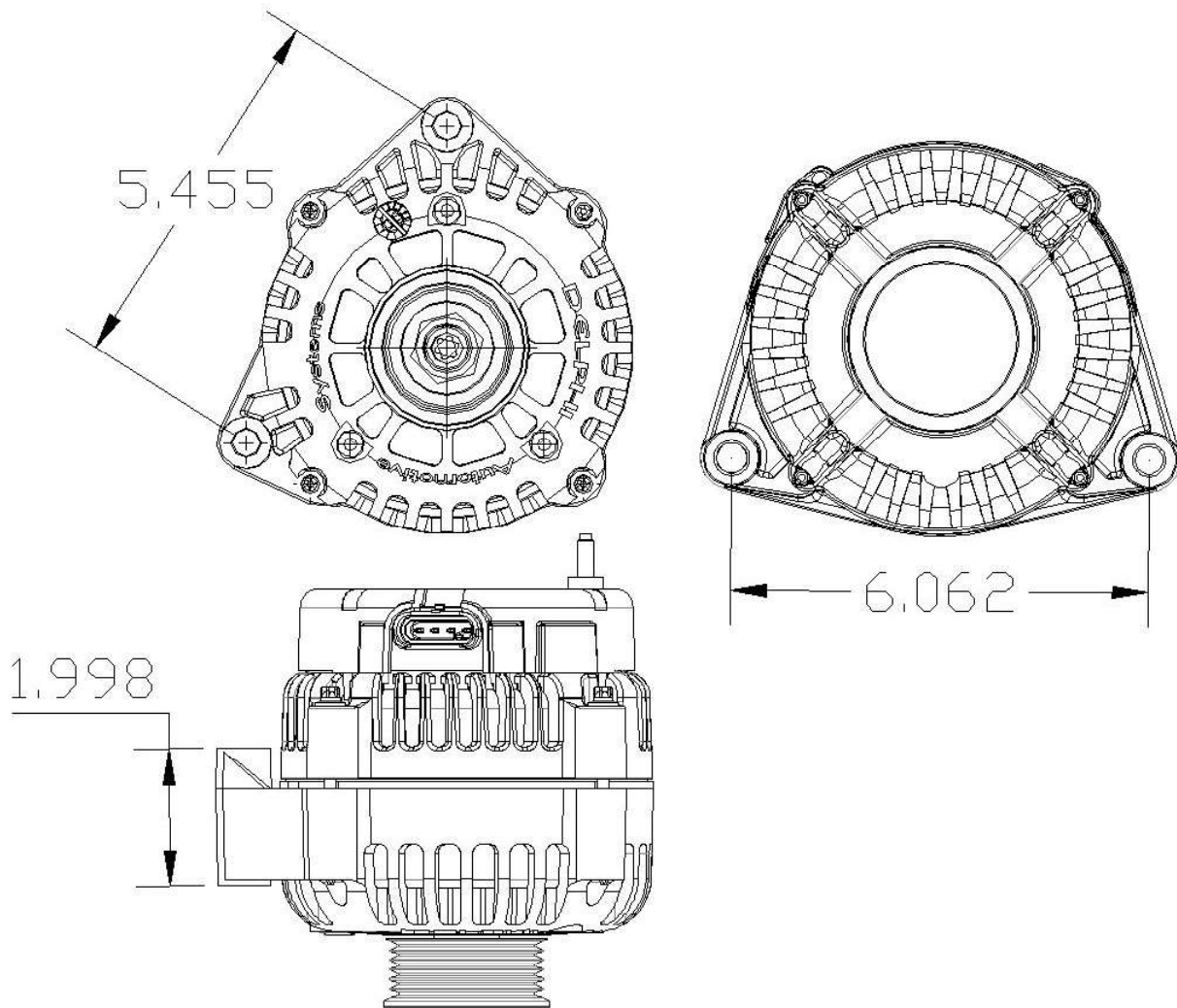

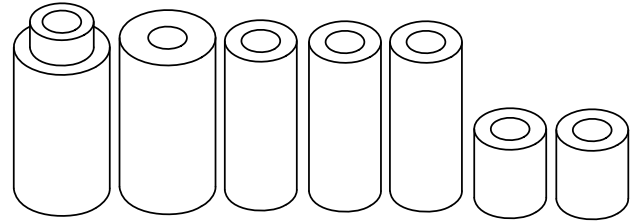
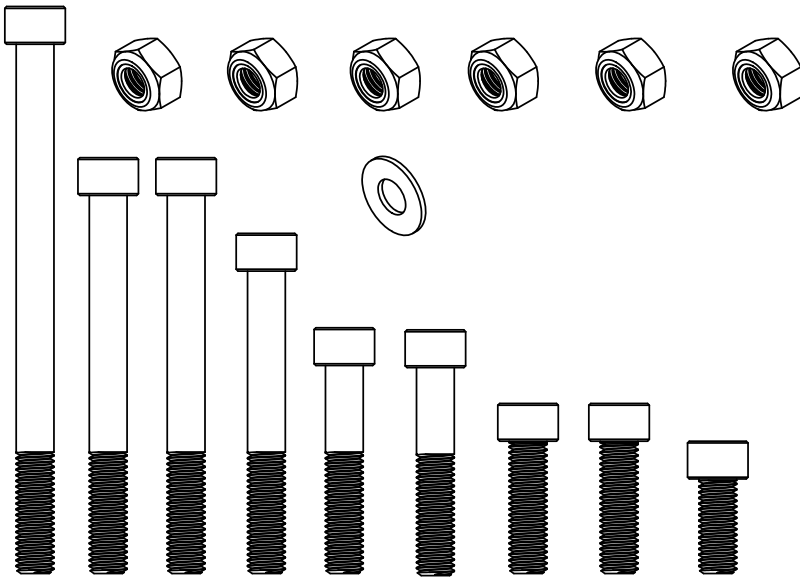

QTY.	SPACERS
1	1" x 1.850 Stepped Idler Spacer
1	1" x 1.900" Spacer
3	3/4" x 1.900" Spacer
2	3/4" x .875" Spacer

QTY.	BOLTS
1	10MM X 140MM SHA
2	10MM X 100MM SHA
1	10MM x 80MM SHA
2	10MM x 55MM SHA
2	10MM x 35MM SHA
1	10MM X 25MM SHA
6	10MM Nylon Insert Lock Nuts
1	10MM x 1" x .125" Washer (black oxide)

QTY.	PARTS
1	Front A/C Bracket
1	Rear A/C Bracket
1	A/C Idler Pulley

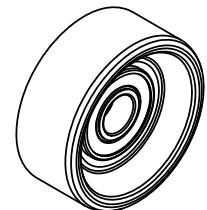
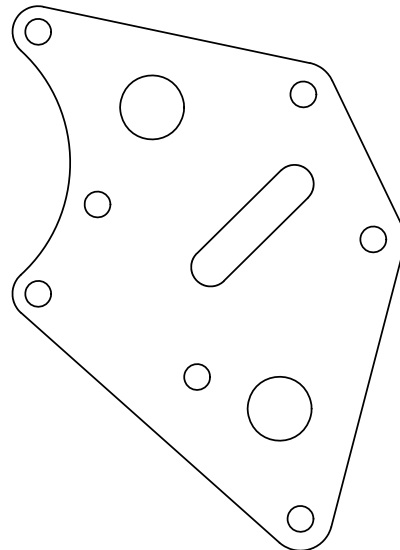
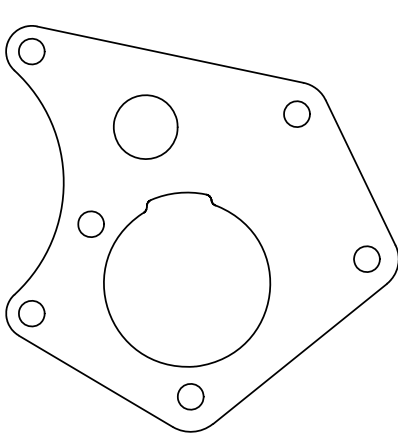

Tool/Supplies List

Loctite Threadlocker Blue 242

17mm socket/wrench

#8 Metric bit Socket / Allen Wrench

Installation Notes:

- Do not torque bolts until all parts are installed
- Water pump will need to be removed to gain access to the lower bracket bolt
- We recommend Applying blue 242 Loctite to any bolts threaded directly into the aluminum cylinder head, it is not needed on any bolts secured with a lock nut

ZL1/LSA Notes:

If this is a LSA/LZ1 Engine, please carefully unhook and remove the bypass solenoid and bracket as seen in the diagram to the right. the stock location interferes with the A/C idler pulley location. we recommend taking pictures and noting the original hose routing for relocation.

*See our LSA / ZL1 Supercharger Accessory Drive kit instructions for alternate mounting locations

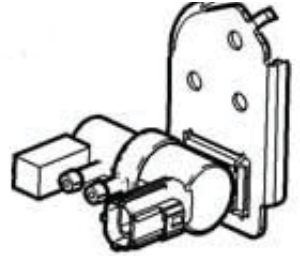

1: Remove the 6 rib pulley from the Corvette belt tensioner

2: bench assemble the front and rear bracket as shown, leave bolts loose

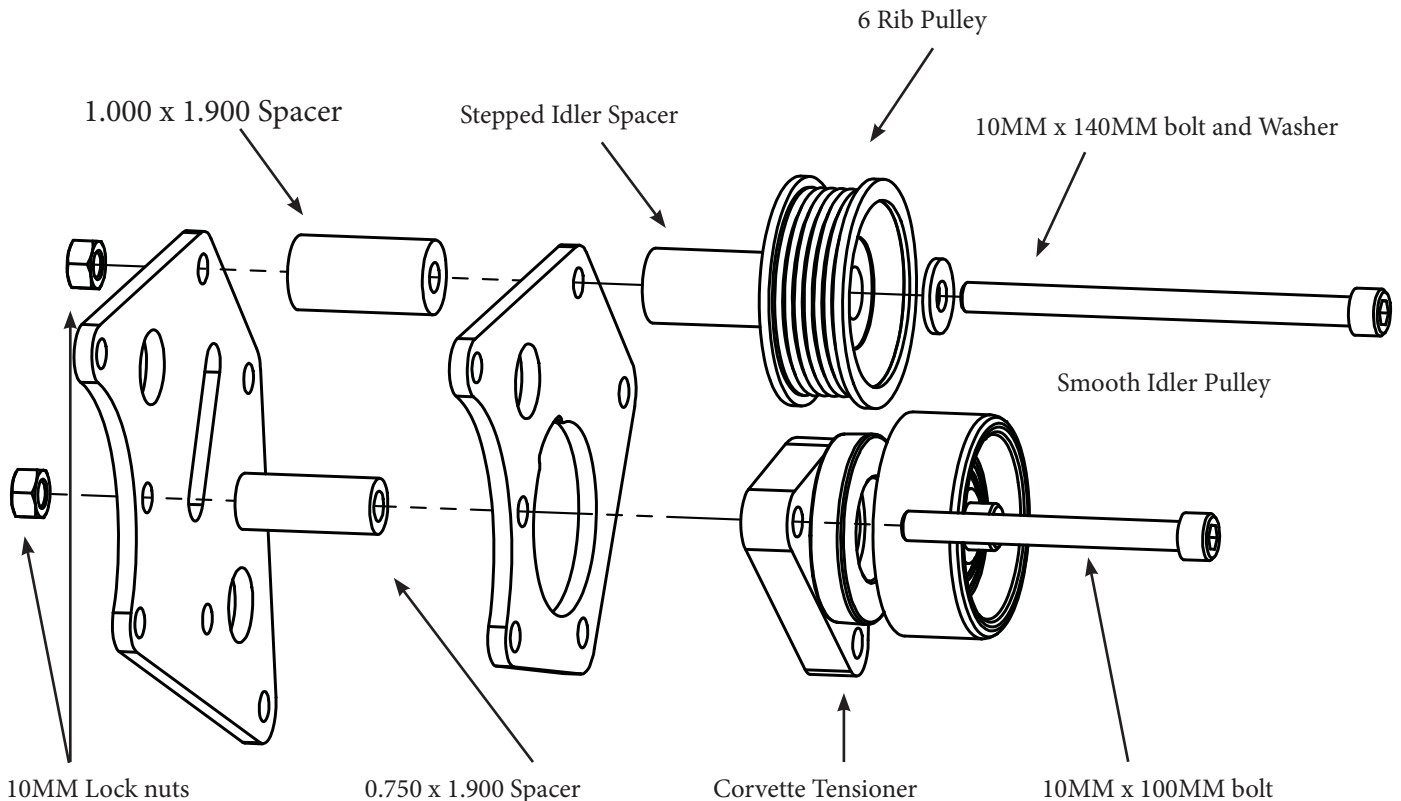

3: Attach the bracket assembly to the passenger side cylinder head

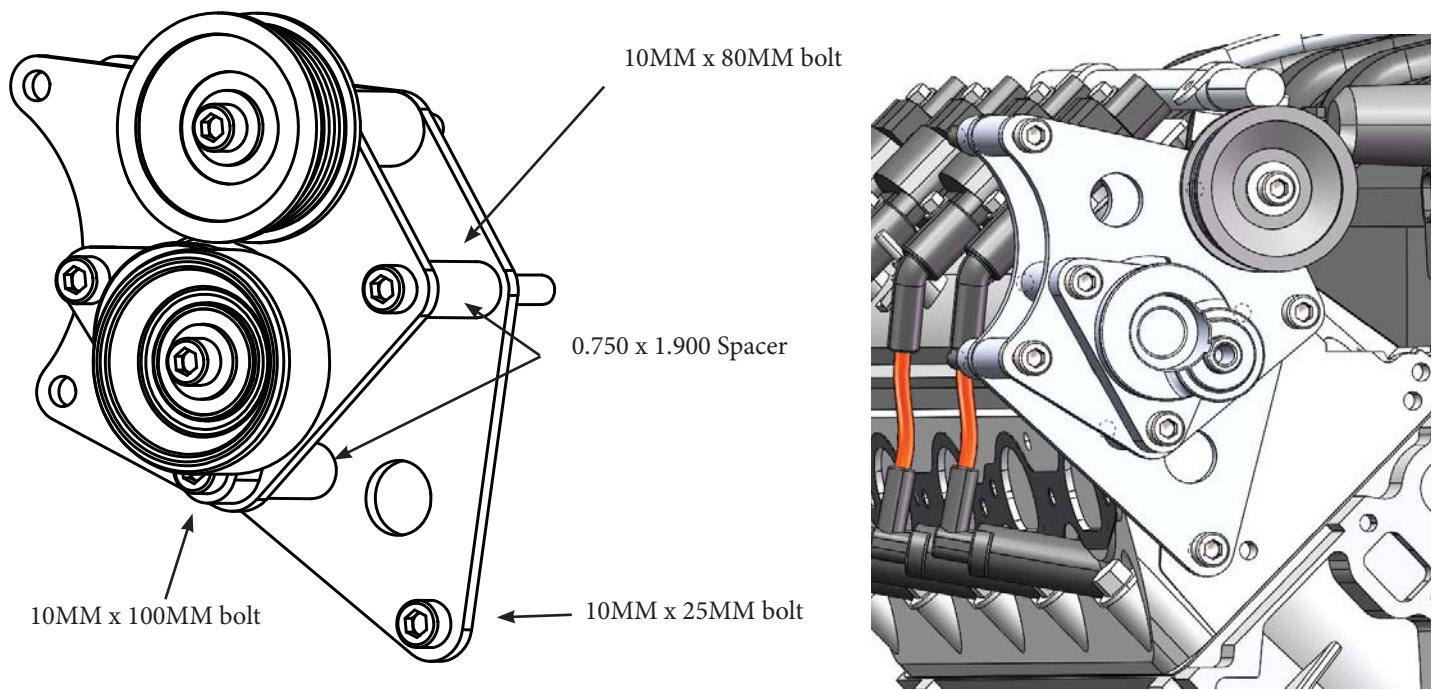

4: Attach the A/C compressor

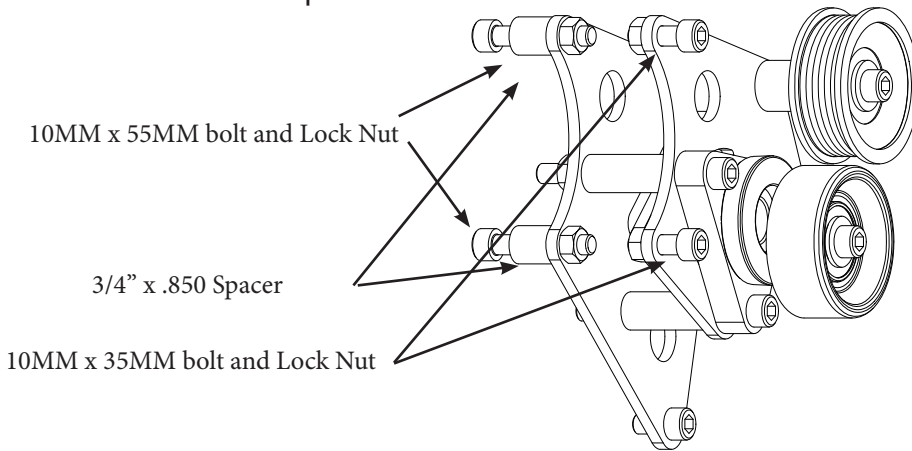

5: Torque all 10mm bolts to 25ft-lbs (34 N-m)

6: Install Serpentine Belt

Due to variations beyond our control some applications may require a shorter or longer belt. use a belt length that will put the belt tensioner indicator in the mid travel position as shown in the picture to the left.

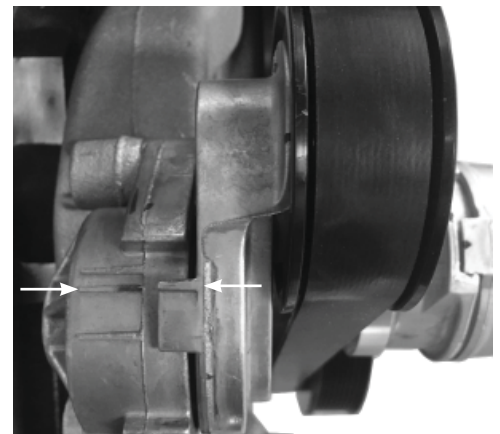

LSX Concepts - LSA Bypass Solenoid Placement

www.lsxconcepts.com

LSA Bypass Solenoid

Most overdriven boosted application and after-market ECM's do not use the bypass solenoid, however if you are running the bypass solenoid in your application it will need to be modified to clear the upper idler pulley on the High Mount A/C kit

Pictured below are a two examples.

NOTE: Both examples use 4MM tubing which can be purchasred from Amazon for under 10.00

Example 1 : this example shows the stock bracket flipped and trimmed, using all the original hosing end with the factory tubing removed and repaced with Black 4mm x 2.5mm Pneumatic Polyurethane PU Air Hose Tube

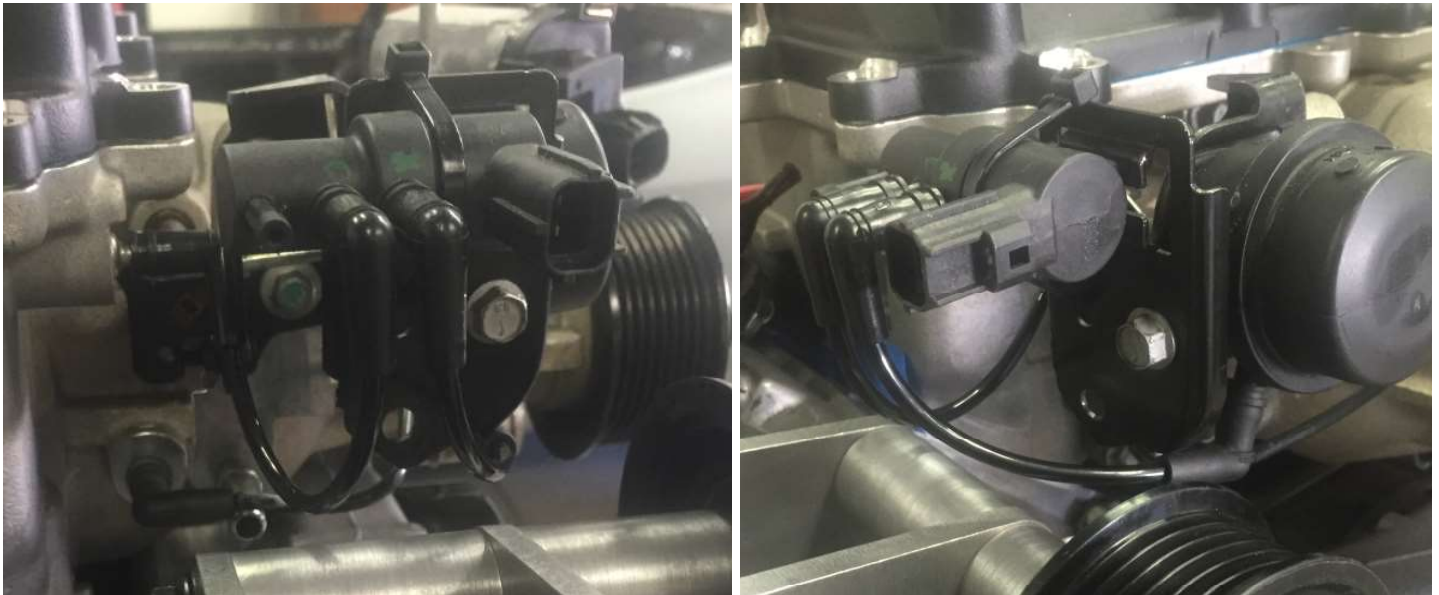

Example 2: this example is the same orientation as the last example but this one is shown using custom bent Stainless Steel 304 Capillary Tubing 4mm OD

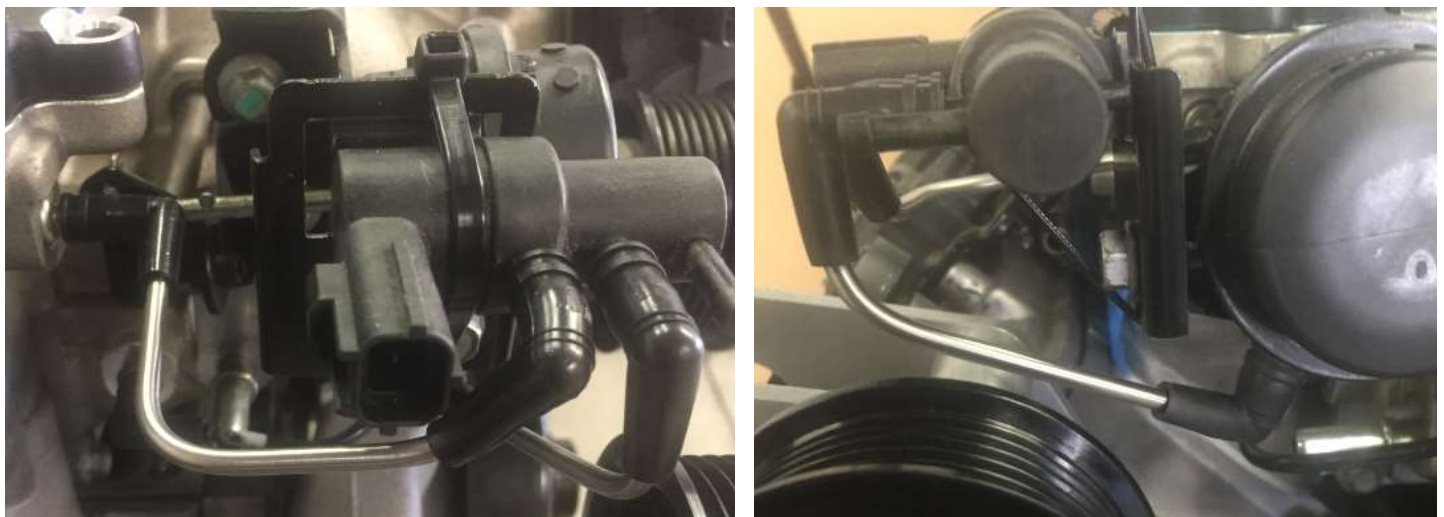

Instructions

1. MOUNTING TENSIONER

- a) Install the Tensioner Mount Bracket on the side of the Engine Block. Apply a small amount of Loctite to the threads and torque the (3) M10-1.5 x 35MM Socket Head Screws to 25 ft. lbs.

Note: The "Cloverleaf" Housing is factory installed on the Tensioner Mount Bracket and the four M6 screws are already torqued to specification.

- b) Place the "Cloverleaf" into its Housing with the #3 position to the left side. (as seen in the picture to the right)
- c) Install the Tensioner onto the Cloverleaf Housing. Lightly snug the retaining bolt
- d) Install the 10 Rib Tensioner Pulley and torque to 30ft. lbs. – **Note: The factory bolt is left-handed, please take care when installing and removing this bolt as they are not sold separately by GM**

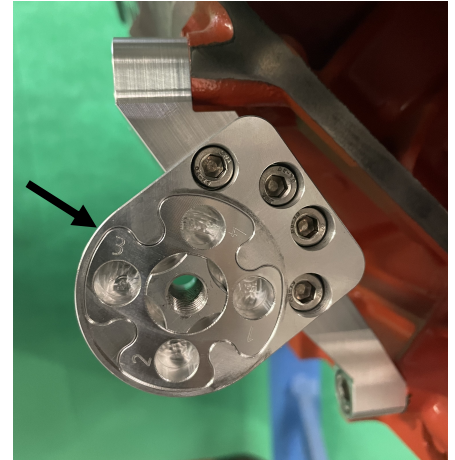

2. INSTALL SUPPORT ARM ONTO WATER PUMP

- a) If you are installing this kit with a High Mount A/C kit, install the A/C first
- b) Install the Support Arm onto the Water Pump. Use (2) M8 Hex Head Bolts and M8 washers as shown.

NOTE: Test the Support Arm and Spacer alignment to the Rear Bearing Support Plate. The Support Arm may need minor adjustment to line up with the upper hole in the Rear Bearing Support. There is enough clearance in the Support Arm mounting bolt holes to do so.

- c) Once the Support Arm is fitted, apply a small amount of blue Loctite, torque the bolts to 15 ft. lbs. NOTE: remove one bolt at a time to keep bracket lined up with the upper bolt hole on the Rear Bearing Support Plate.

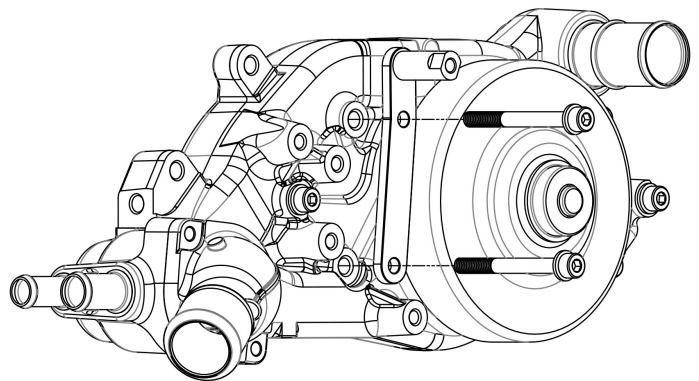

3. INSTALL REAR BEARING SUPPORT PLATE AND STUDS

- a) Bolt the Rear Bearing Support Plate to the Water Pump being sure all the holes line up. Then remove the bolts one at a time. Add a small amount of Blue Loctite and torque the (5) M8-1.25 bolts to 15 ft. lbs.
- b) Snug the upper right Pulley Mounting Stud into the Rear Bearing Support Plate. There are 2 positions marked E and F. Slip on the smooth Idler Pulley. Pick the closest location to the Blower pulley and still be able to easily install the belt between the Blower Pulley and the smooth Idler Pulley. Remove the Idler Pulley and Install the (1) Pulley Standoff Retention Nut. Apply a small amount of Anti-Seize to the threads and Torque to 20 ft. lbs.
- c) Snug the center left Pulley Mounting Stud into the Rear Bearing Support Plate. Install (1) Pulley Standoff Retention Nut. Apply a small amount of Anti-Seize to the threads and Torque to 20 ft. lbs.
- d) Snug the lower Pulley Mounting Stud into the Rear Bearing Support Plate. There are 4 positions. Start in position "B". Install the (1) Pulley Standoff Retention Nut. Apply a small amount of Anti-Seize to the threads and Torque to 20 ft. lbs.
- e) Install the Pulleys with snap rings facing outwards and install the outside (3) Pulley Standoff Retention Nuts. Apply a small amount of Anti-Seize to the threads and Torque to 20 ft. lbs.

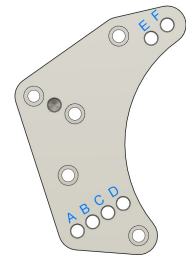
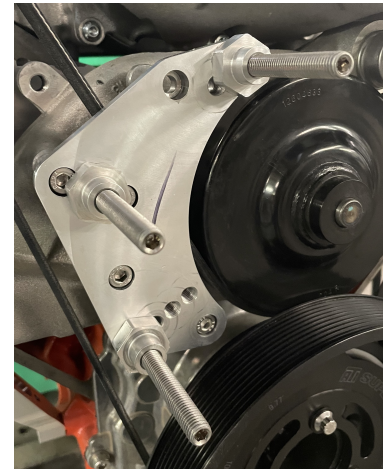

3. DISCOVER BELT LENGTH

- a) Simply wrap the Cloth Tailors Tape Measure (provided) following the belt path around the pulleys according to the picture. Your belt length should be ½ inch shorter than that measurement.
- b) Available belt lengths may vary, the catalog may skip the length you desire. Pick the one closest to your measurement. If you need assistance in finding the right belt, give us a call @ 844-579-7927 or email us at sales@lsxconcepts.com. The lower stud location can adjust for ½ inch longer or shorter belts, it's ½ inch belt length per hole position. Relocate the stud as necessary and re-torque the Pulley Standoff Retention Nut to 20 ft. lbs.
- c) To fit the belt requires two people, one to install the belt and one to inspect the tensioner. The tensioner gauge is located on the bottom side of the tensioner. We have found it helpful to pull the tensioner to its full tension mark and draw a line with a felt pen on the top of the housing for easy viewing.

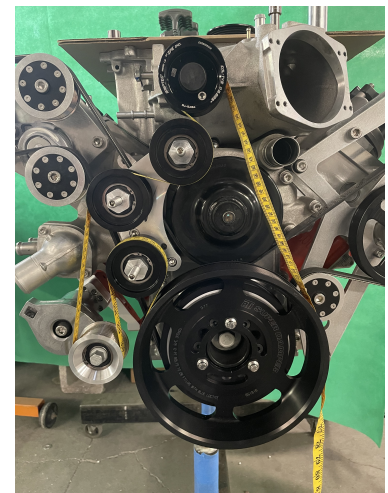

4. SYSTEM ADJUSTMENT VALUES

There are two belt adjustments, a coarse adjustment by changing stud location and fine adjustment by moving the cloverleaf location. The overall system allows for over 2 inches of belt length adjustment.

- a. The lower Pulley Stud location is worth about ½ inch in belt length. You may find that if the belt you have is longer or shorter than desired you may wish to alter the lower Pulley Stud location from the onset.
- b. Each number on the "Cloverleaf" is worth about 3/16 in belt length and about a .070 change on the Tensioner housing gauge. The lower the number being looser
- c. Each stud location is worth about 4 numbers on the "Cloverleaf" allowing some overlay for fine belt tuning without altering pulley stud location.

5. DISCOVER THE ACTUAL BELT TENSION

- a. While the Tensioner is UNLOADED slip the belt on being sure the serpentine side of the belt matches the pulley grooves.

NOTE: If the belt is too tight to install, remove the tensioner and place the "Cloverleaf" in the #1 position, then try to reinstall the belt again. If the belt is still too tight move the lower stud and pulley to the "A" position and the "Cloverleaf" back to #3 position and try again.

- b. Once the belt is installed, release the Tensioner, and view the gauge. Moving the "Cloverleaf" by one number alters the gauge by .070". If you reach the # 8 position on the "Cloverleaf" and the belt is still too loose, move the lower Pulley Stud to the "C" position and the "Cloverleaf" to #3 and try again. Torque the Tensioner retaining bolt to 20 ft. lbs.

6. INSTALL THE FRONT DOUBLE SHEER PLATE

- a. Recheck the Pulley Standoff Retention Nuts for being tight. Torque to 20 ft. lbs.
- b. Install the Front Plate. Install the (3) aluminum Washers and the (3) Nylon Lock Nuts. Torque to 25 ft. lbs.
- c. Torque the Tensioner retaining bolt to 20 ft. lbs.

7. FINAL ASSEMBLY - TORQUE VALUES

The (5) M6 Rear Plate mounting bolts - torque to 15 ft. lbs. (M6)

Loctite the (3) M10 Pulley Studs - Hand Tighten till snug, do not over tighten

Pulley Standoff Retention Nuts - torque to 20 ft. lbs. (use Anti-Seize on threads)

Front Cover Nylon Lock Nuts torque to 25 ft. lbs.

Tensioner retaining bolt to 25 ft. lbs. (M10)

8. Belts

A complete listing of belts by length can be found on the Summit Racing website (scan QR code to visit Summit Racings 10 rib belt collection)

<https://www.summitracing.com/search/part-type/accessory-belts?N=number-of-belt-ribs%3A10&SortBy=BestKeywordMatch&SortOrder=Ascending&keyword=serpentine%20belts>

If you are unable to find a suitable belt for your combination give us a call or email with your measurements and we will be happy to find you a belt to fit your combination

Known Combinations

For a list of known/proven belt combinations visit the website

<https://www.lsxconcepts.com/pages/instructions-billet-10-rib-lsa-supercharger-flex-drive>

