



TxIsoRail 4-20 mA

ISOLATED TEMPERATURE TRANSMITTER – OPERATION MANUAL V1.0x G

SPECIFICATIONS

Sensor input: User defined. The supported sensors are listed in **Table 1**, along with their maximum ranges.

Thermocouples: Types J, K, R, S, T, N, E and B to IEC 60584 (ITS-90). Impedance $\gg 1 \text{ M}\Omega$

Pt100: Excitation: 180 μA , 2 or 3-wire connection (for 2-wire sensors, tie, terminals 2 and 3 together). $\alpha = 0.00385$, according to IEC 60751 (ITS-90).

Voltage: 0 to 50 mVdc, 0 to 10 Vdc. Impedance $\gg 1 \text{ M}\Omega$.
* **Note:** 0-10 Vdc input type requires an internal jumper switching.
0 to 20 mA, 4 to 20 mA. Impedance $15.0 \Omega (+ 1.9 \text{ Vdc})$.

Sensor Type	Range	Minimum measurement span
Thermocouple K	-150 to 1370 °C / -238 to 2498 °F	100 °C
Thermocouple J	-100 to 760 °C / -148 to 1400 °F	100 °C
Thermocouple R	-50 to 1760 °C / -58 to 3200 °F	400 °C
Thermocouple S	-50 to 1760 °C / -58 to 3200 °F	400 °C
Thermocouple T	-160 to 400 °C / -256 to 752 °F	100 °C
Thermocouple N	-270 to 1300 °C / -454 to 2372 °F	100 °C
Thermocouple E	-90 to 720 °C / -130 to 1328 °F	100 °C
Thermocouple B	500 to 1820 °C / 932 to 3308 °F	400 °C
Pt100	-200 to 600 °C / -328 to 1112 °F	40 °C
Voltage	0 to 50 mV	5 mV
	* 0 to 10 V	1 V
Current	0 to 20 mA	2 mA
	4 to 20 mA	2 mA

Table 1 – Transmitter input sensors

Output: 2-wire 4-20 mA, linear with respect to the measured signal.

Resolution: 0.001 mA (14 bits)

Total Accuracy: Better than 0.3 % of the maximum span for thermocouples and 0.2 % for Pt100 and voltage;

Response Time: < 500 ms

Isolation: Between the sensor and the 4-20 mA loop (1000 V / 1 min).

Power Supply: 12 to 35 Vdc, across the transmitter;

Maximum Load (RL): $RL (\text{max.}) = (V_{dc} - 12) / 0.02 [\Omega]$
Were: V_{dc} = Power supply voltage

Operating Temperature: -40 to 85 °C

Humidity: 0 to 90 % UR

Electromagnetic Compatibility: EN 50081-2, EN 50082-2

Internal protection against polarity inversion.

Cold junction compensation for thermocouples.

CONFIGURATION

If the transmitter is already configured as required by the application (sensor type, range, etc), it may be installed and used right away. However, if a distinct configuration is required, this can be done through the **TxConfig software** and the **TxConfig Interface**.

The TxConfig interface and software can be purchased from the manufacturer or at its authorized distributors and representatives. Updates for the software are available at our website. To install the TxConfig software, run the **Tx_setup.exe** file and follow the instructions.

Serial port configuration errors may occur when other devices are sharing the same port (ex.: Palm Hot Synch). Close all serial port applications prior to using the TxConfig software.

The TxConfig interface connects the transmitter to the PC, as shown in **Fig. 1** and **2**. There are two types of interface: TxConfig-RS232 and TxConfig-USB.

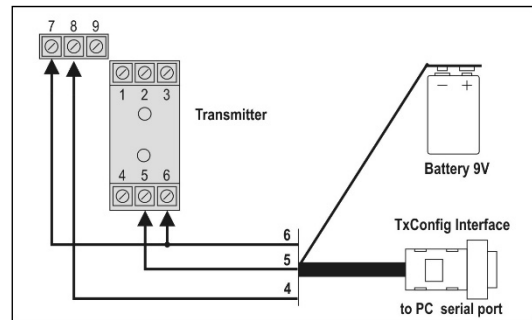

Fig. 1 – TxConfig Interface connections model RS232

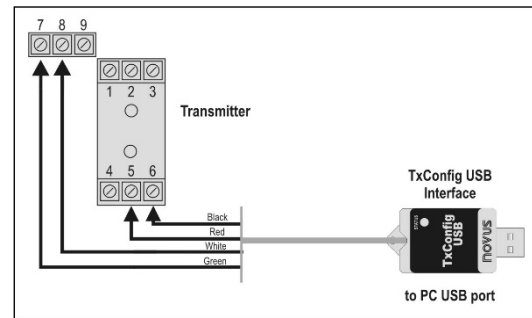

Fig. 2 – TxConfig Interface USB connections

Once the connection is accomplished, the software shows the configuration options of the transmitter model attached. Access the **Help** for usage instructions.

The TxConfig screen is shown in Fig. 3.

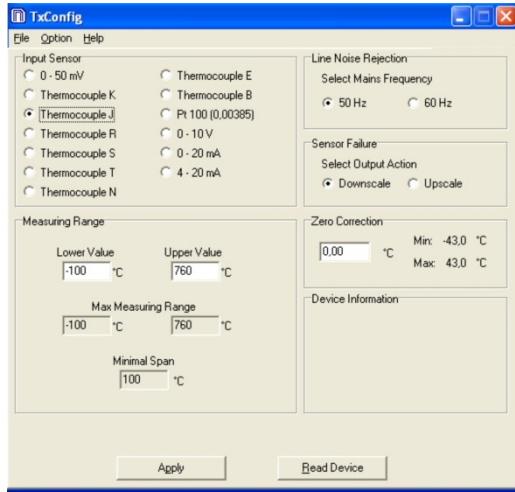

Fig. 3 – TxConfig main screen

The fields in the screen mean:

- Input Sensor:** Choose the desired temperature sensor among the available options. See Table 1.
- Measuring Range:** Defines the beginning and the end of the range.
When the Low Scale Limit is configured with a value higher than the Full Scale Limit, the current output will have a decrescent behavior (20~4 mA).
The values configured in these fields can not be beyond the sensor measuring range. The minimum span value has to be observed as well (see Table 01).
- Line Noise Rejection:** The transmitter incorporates a digital filter to cancel the induced noise from the 50 or 60 Hz systems. For better performance, select the line frequency used in your country.
- Sensor Failure:** establishes the transmitter output behavior (upscale or down-scale) in the presence of a sensor fail.
- Zero Correction:** Allows for small sensor corrections.
- Device Information:** The *Device Information* box contains relevant data concerning a particular transmitter. Please pass along this information when contacting the technical assistance department.
- Apply:** Sends a new configuration to the transmitter.
- Read Device:** Brings to the screen the current transmitter parameters configuration.

Note: The factory default configuration is (unless otherwise specified or ordered):

- Pt100 input, 0 to 100 °C
- 60 Hz filtering and upscale (20 mA) output for sensor fail.

The transmitter must be powered in order to be configured. The TxConfig-USB interface provides the necessary power. The TxConfig-RS232 interface, however, requires an auxiliary supply to guarantee a reliable communication with the computer.

An external 9 V battery can be used for this purpose (Fig. 1). An alternative is to configure the transmitter while it is in operation; this way, the needed energy is supplied by the current loop, as in Fig. 4.

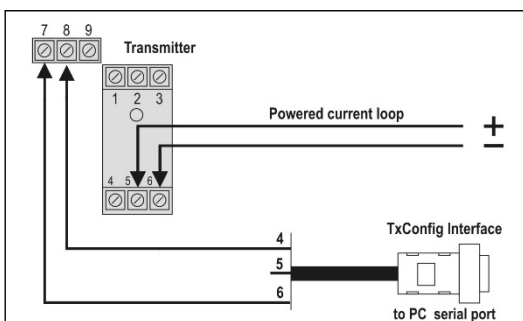

Fig. 4 – TxConfig Interface connections – Loop powered

The TxConfig interfaces contain dedicated circuitry for proper communication between transmitters and computer. Always make use of the TxConfig interfaces for configuration purposes, otherwise the transmitters may get damaged, voiding the warranty.

MECHANICAL INSTALLATION

The transmitter is intended for DIN rail mounting. Its drawing is presented in Fig. 5.

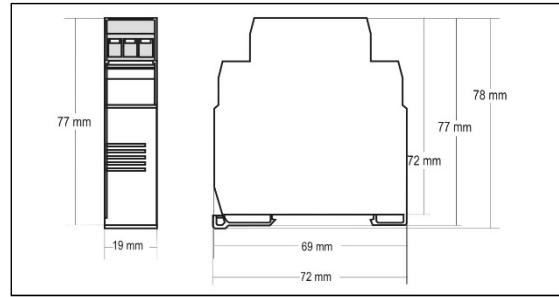

Fig. 5 – Transmitter dimensions

ELECTRICAL CONNECTIONS

Figure below shows the transmitter connections to the sensor and power supply. Terminals 1, 2 e 3 are used for sensor input. For 2-wire Pt100, terminals 2 and 3 shall be connected together.

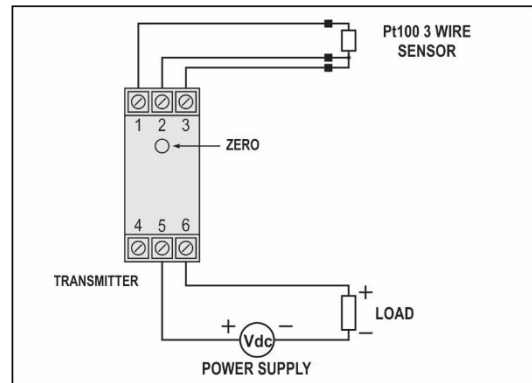

Fig. 6 – Transmitter wiring (Pt100)

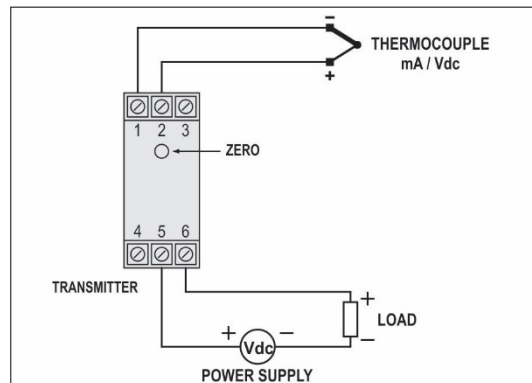

Fig. 7 – Transmitter wiring (Thermocouple, mA, Vdc)

The **LOAD** represents the input shunt of an instrument measuring the 4-20 current loop.

Electrical Connections – 0-10 Vdc Input

For 0-10 Vdc input, the transmitter requires an internal hardware configuration change. Please open the instrument case and change the jumper shown in Fig. 8.

- Position 1-2 : 0-10 Vdc input
- Position 2-3 : all other input types

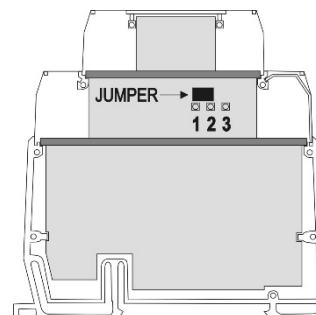

Fig. 8 – Jumper position for 0-10 Vdc input

OPERATION

All input types and the 4-20 mA output current are factory calibrated.

However, if desired by the user, a manual offset trim is implemented to provide fine adjustments to the signal in the field. This is accomplished by the front key ZERO, located under the frontal label in order to avoid accidental adjustments. Using a small tool (2 mm diameter), press and hold the desired key for at least 2 seconds to increase or decrease the output current. When the output current is reached, the key must be released.

The offset correction can also be accomplished by the TxConfig software. See in **Figure 3** the **Zero Correction** field for this purpose. The serial adaptor can be connected to the transmitter while it is operating in the process.

The user must choose the sensor and configure the sensor span which best suit the application. The sensor span must not exceed the maximum range supported by the transmitter for a particular sensor, neither be lower than the minimum span.

It is important to note that the transmitter accuracy is related to the total sensor span of a sensor, regardless of the output scale (span) configured. Example:

- Pt100; maximum input span of -200 to +650 °C, 0.2 % accuracy.
- Maximum error: 1.2 °C (0.2 % of 800 °C)
- This error is the same no matter if total span is used (-200 to 650 °C) or a narrower user-defined span is used, like 0 to 100 °C.

Note: When using a Pt100 simulator, make sure the transmitter Pt100 excitation current (0.18 mA) is compatible with the simulator specification.

SAFETY INFORMATION

Any control system design should take into account that any part of the system has the potential to fail. This product is not a protection or safety device and its alarms are not intended to protect against product failures. Independent safety devices should be always provided if personnel or property are at risk.

Product performance and specifications may be affected by its environment and installation. It's user's responsibility to assure proper grounding, shielding, cable routing and electrical noise filtering, in accordance with local regulations, EMC standards and good installation practices.

SUPPORT AND MAINTENANCE

This product contains no serviceable parts inside. Contact our local distributor in case you need authorized service. For troubleshooting, visit our FAQ at www.novusautomation.com.

LIMITED WARRANTY AND LIMITATION OF LIABILITY

NOVUS warrants to the original purchaser that this product is free from defects in material and workmanship under normal use and service within one (1) year from the date of shipment from factory or from its official sales channel to the original purchaser.

NOVUS liability under this warranty shall not in any case exceed the cost of correcting defects in the product or of supplying replacement product as herein provided and upon the expiration of the warranty period all such liability shall terminate.

For complete information on warranty and liability limitations, check appropriate section in our web site: www.novusautomation.com.