

# PyroMiniBus Series

## Operator's Guide



Distributed by: IOThrifty  
website: [IOThrifty.com](http://IOThrifty.com)  
email: [info@IOThrifty.com](mailto:info@IOThrifty.com)  
Phone: (860)733-1117

**CALEX**  
ELECTRONICS LIMITED

PyroMiniBus non-contact infrared sensors measure temperatures from -20°C to 1000°C and provide an RS485 Modbus RTU interface.

The sensors are capable of being used in ambient temperatures up to 120°C without cooling (XCF models: 70°C). They may be connected directly to third-party Modbus Masters, and they are compatible with the optional PM180 6-channel touch screen interface, which provides temperature display, data logging, alarms and analogue outputs.

A 6-channel junction box (model PMBHUB) is available to easily connect PyroMiniBus sensors to the PM180 as a complete temperature measurement system.

## SENSOR SPECIFICATIONS

### Model Numbers

Field of View	Model Number
2:1	PMB21
20:1	PMB201
Close Focus (Ø3.5 mm at distance 50 mm)	PMBXCF

General	
<b>Interface</b>	RS485 Modbus RTU
<b>Accuracy</b>	±1% of reading or ±1°C whichever is greater
<b>Repeatability</b>	± 0.5% of reading or ± 0.5°C whichever is greater
<b>Emissivity</b>	0.2 to 1.0
<b>Response Time</b>	125 ms (90% response)
<b>Spectral Range</b>	8 to 14 µm
<b>Supply Voltage</b>	24 V DC (minimum sensor voltage 6 V DC, maximum 28 V DC)
<b>Supply Current</b>	50 mA max.
<b>Baud Rate</b>	9600 baud *
<b>Format</b>	8 data bits, no parity, 1 stop bit *
Mechanical	
<b>Construction</b>	Stainless Steel
<b>Dimensions</b>	18 mm diameter x 45 mm long (excluding cable gland)
<b>Thread Mounting</b>	M16 x 1 mm pitch
<b>Cable Length</b>	1 m standard, longer cable available to order
<b>Weight with 1 m Cable</b>	85 g
Environmental	
<b>Environmental Rating</b>	IP65
<b>Ambient Temperature</b>	0°C to 120°C (XCF models: 70°C)
<b>Relative Humidity</b>	95% max. non-condensing

\* Other configurations available upon request

## DIMENSIONS

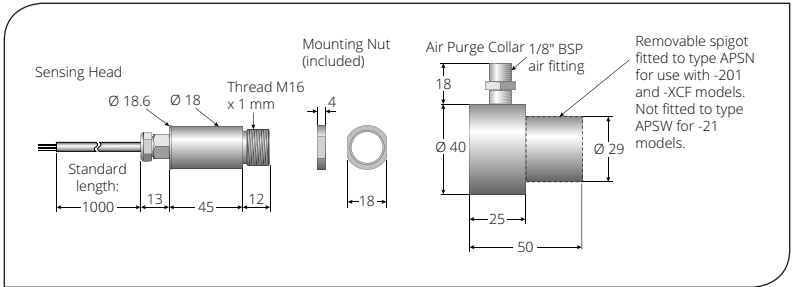

## ACCESSORIES

A range of accessories to suit different applications and industrial environments is available. These may be ordered at any time and added on-site.

- Fixed mounting bracket
- Adjustable mounting bracket
- Air purge collar
- Laser sighting tool
- Junction box for 6 sensors
- PM180 6-channel touch screen interface module with data logging
- Analogue output module
- Relay output module
- Protective window in stainless steel holder

## OPTIONS

The following options are available. Options are factory installed and must be ordered with the sensor.

- Certificate of calibration
- Longer cable (up to 30 m factory-fitted; cable may be extended by user)

## OPTICS

The optical charts below indicate the nominal target spot diameter at any given distance from the sensing head and assume 90% energy.

Sensors may be used at longer distances than these diagrams show.

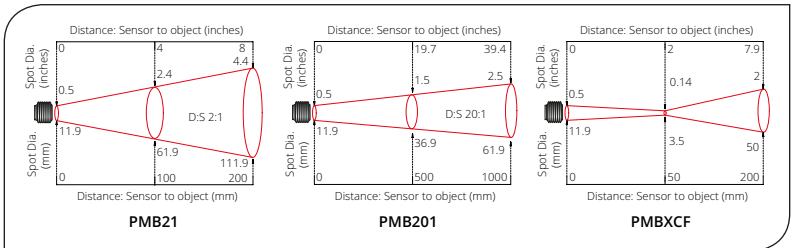

## INSTALLATION

The installation process consists of the following stages:

- Preparation
- Mechanical installation
- Electrical installation

Please read the following sections thoroughly before proceeding with the installation.

## PREPARATION

Ensure that the sensor is positioned so that it is focused on the target only.

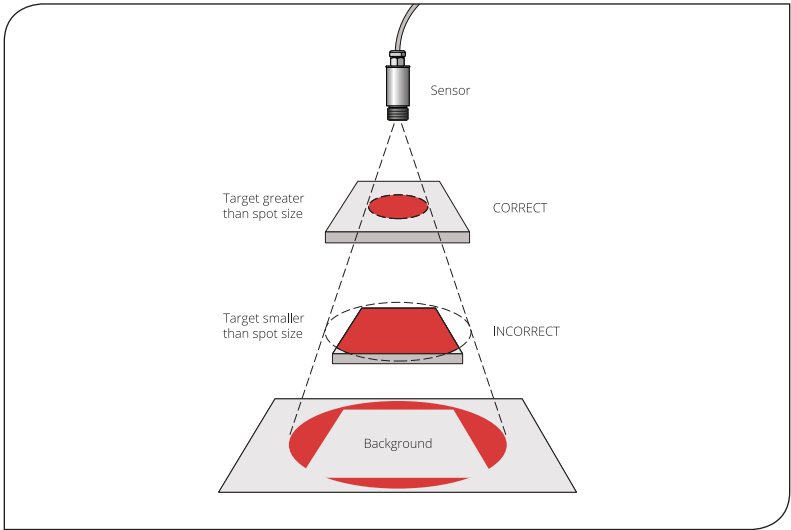

## DISTANCE AND SPOT SIZE

The size of the area (spot size) to be measured determines the distance between the sensor and the target. The spot size must not be larger than the target. The sensor should be mounted so that the measured spot size is smaller than the target. We normally recommend that the target should be at least twice the size of the measured spot for maximum accuracy.

## AMBIENT TEMPERATURE

The sensor is designed to operate in ambient temperatures from 0°C to 120°C (XCF models: 70°C).

Avoid thermal shock. Allow 20 minutes for the unit to adjust to large changes in ambient temperature.

## ATMOSPHERIC QUALITY

Smoke, fumes or dust can contaminate the lens and cause errors in temperature measurement.

In these types of environment the air purge collar should be used to help keep the lens clean.

## ELECTRICAL INTERFERENCE

Do not operate the sensor near large electromagnetic fields (e.g. around arc welders, generators and induction heaters). Electromagnetic interference can cause communication errors.

## WIRING

Check the distance between the sensor and the Modbus Master. If necessary, the sensor can be ordered with a longer cable attached.

## POWER SUPPLY

Be sure to use a 24 V DC power supply. The maximum current draw is 50 mA per sensor.

## MECHANICAL INSTALLATION

All sensors come with a 1 m cable and a mounting nut. The sensor can be mounted on brackets or cut outs of your own design, or you can use the fixed and adjustable mounting bracket accessories which are shown below.

Note: The sensor must be grounded at only one point, either the cable shield or the sensor housing, but not both.

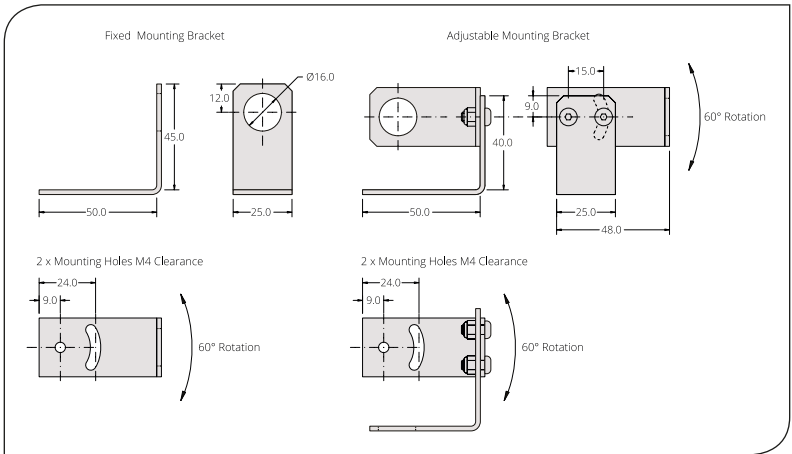

## AIR PURGE COLLAR

The air purge collar below is used to keep dust, fumes, moisture, and other contaminants away from the lens. It must be screwed in fully. Air flows into the 1/8" BSP fitting and out of the front aperture. Air flow should be no more than 5 to 15 litres/min.

Clean or 'instrument' air is recommended.

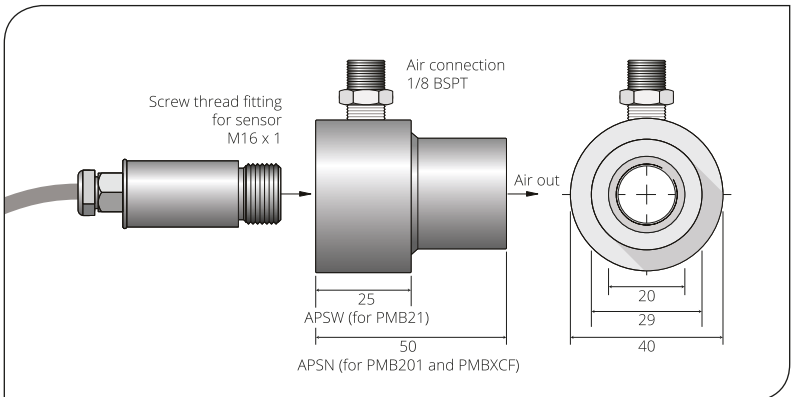

## ELECTRICAL INSTALLATION

This diagram shows how to connect the sensors and output modules to a Modbus Master, such as a Modbus PLC, SCADA system, Calex Panel PC or PM180 touch screen terminal.

Up to 247 slave devices, such as PyroMiniBus sensors and output modules, can be connected to the same Modbus network.

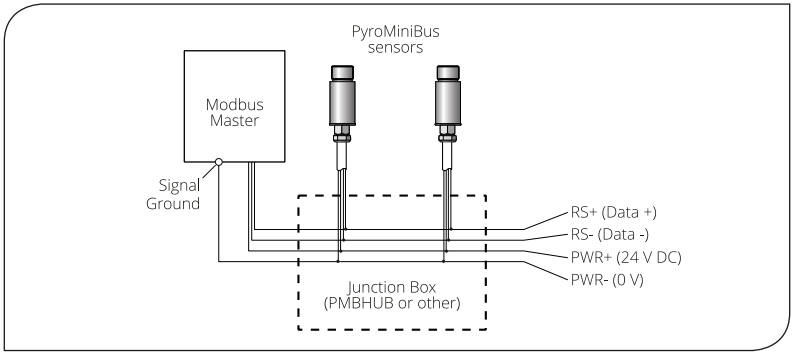

## SHIELDING

PyroMiniBus sensors use a shielded cable. The RS485 network bus cable and junction boxes should also be shielded.

Avoid ground loops. Ensure there is only one path to ground from any point on the network shielding.

**Note:** The sensing head metalwork forms part of the shield.

Ensure the PWR- wires of all sensors and GND of all output modules are connected to the Signal Ground of the Modbus Master (or PWR- of the PM180 Modbus Master interface) and the 0 V of the sensor power supply.

For more information on electrical connections to the PM180, including how to connect the Modbus Slave interface, please see the PM180 section of this Operator's Guide.

## IMPORTANT

Do not connect or disconnect Modbus devices with power on. Always disconnect power before modifying electrical connections.

## SENSOR WIRE COLOUR CODES:

WIRE COLOUR	WIRE IDENTITY
Red	PWR+
Black	PWR-
White	RS+
Green	RS-

## MODBUS OVER SERIAL LINE (RS485)

INTERFACE		SUPPORTED FUNCTIONS	
Baud rate	9600	Read register	0x03, 0x04
Format	8 data, No parity, 1 stop	Write single register	0x06
Reply delay (ms)	20	Write multiple register	0x10

## LIST OF MODBUS REGISTERS

The list below includes all available addresses on the PyroMiniBus sensor.

R = Read, W = Write

Address	Length (words)	Description	R/W
0x00	1	Sensor Type (17 for PyroMiniBus)	R
0x01	1	Field of view 0 for 2:1; 1 for 20:1	R
0x02	2	Serial number	R
0x04	1	Modbus slave ID (slave address)	R/W
0x05	1	Reflected Energy Compensation 0 for Off; 1 for On	R/W
0x06	1	Reflected Temperature	R/W
0x07	1	Emissivity Setting (1 LSB = 0.0001) Minimum 0.2000, Maximum 1.0000	R/W
0x08	1	Hold Mode 0 for Off; 1 for Peak; 2 for Valley	R/W
0x09	1	Hold Period (1 LSB = 0.1 seconds) Minimum 0.1 seconds, Maximum 1200.0 seconds	R/W
0x0A	1	Average Period (1 LSB = 0.1 seconds) Minimum 0.1 seconds, Maximum 60.0 seconds	R/W
0x0B	1	Average Temperature	R
0x0C	1	Minimum Temperature	R
0x0D	1	Maximum Temperature	R
0x0E	1	Filtered Temperature	R
0x0F	1	Unfiltered Temperature	R
0x10	1	Sensor Temperature	R
0x11	1	Status (bits active high) Bit 0: Measurement error Bit 1: Sensor temperature low Bit 2: Sensor temperature high Bit 3: Object temperature low Bit 4: Object temperature high	R
0x16	1	Reflected Temperature (not saved to non-volatile memory)	R/W
0x17	1	Emissivity Setting (not saved to non-volatile memory)	R/W

### Notes:

- 1 All temperature are in tenths of degrees C
- 2 With the exception of addresses 0x16 and 0x17, all write operations are saved to non-volatile memory
- 3 For further information please refer to <http://www.modbus.org/specs.php>
- 4 Use address 255 to communicate with any connected sensor (only one sensor connected)
- 5 Use address 0 to broadcast to all connected sensors (no response expected)

## **OPERATION**

Once the sensor is in position and the power, air, water, and cable connections are secure, the system is ready for continuous operation by completing the following simple steps:

- 1 Turn on the power supply
- 2 Turn on the Modbus Master
- 3 Read / monitor the temperature

## **IMPORTANT**

### **BE AWARE OF THE FOLLOWING WHEN USING THE SENSOR:**

- If the sensor is exposed to significant changes in ambient temperature (hot to cold, or cold to hot), allow 20 minutes for the temperature to stabilise before taking or recording measurements.
- Wires must be connected only to the appropriate terminals.
- Do not damage the cable, as this could provide a path for moisture into the sensor.
- Do not open the sensor housing. This will damage the sensor and invalidate the warranty.

## **MEASURED TEMPERATURES**

### **Average Temperature**

The Unfiltered Temperature, averaged over the Average Period

### **Minimum Temperature**

The lowest measured temperature during the Hold Period

### **Maximum Temperature**

The highest measured temperature during the Hold Period

### **Filtered Temperature**

The measured temperature, including Averaging and Hold Processing

### **Unfiltered Temperature**

The “raw” measured temperature without Averaging or Hold Processing

### **Sensor Temperature**

The temperature inside the sensor body - this is usually a few degrees higher than the ambient temperature.

## **SETTINGS**

Settings can be modified via the PM180 or another Modbus Master.

### **Emissivity Setting**

The emissivity setting should match the emissivity of the target surface. This can be determined experimentally by comparing measurements with a trusted contact probe, or estimated using an emissivity table.

Non-reflective non-metals, such as rubber, foods, thick plastics, organic materials and painted surfaces, generally have a high emissivity, around 0.95. This is the default setting.

Bare, clean metal surfaces can have a very low emissivity, and are often difficult to measure accurately. If possible, a measurable area of the surface should be painted or coated to reduce reflections and increase the emissivity.

If the emissivity setting is being updated is being updated continuously by the Modbus Master, use address 0x17 instead of 0x07 to preserve the sensor's non-volatile memory.

### **Reflected Energy Compensation & Reflected Temperature**

In most applications, the target surface has the same surroundings as the sensor (for



example, it is in the same room). In this case, Reflected Energy Compensation should remain Disabled for an accurate measurement.

However, if the sensor is positioned outside an oven or furnace, with the target object inside, the reflection of the hot furnace interior can affect the measurement. In this case, Reflected Energy Compensation should be turned ON and Reflected Temperature should be set to the temperature inside the oven or furnace.

If Reflected Temperature is being updated continuously by the Modbus Master, use address 0x16 instead of 0x06 to preserve the sensor's non-volatile memory.

**Average Period**

To slow the response time of the sensor, or to reduce fluctuations or noise on the measurement, enter an averaging period here.

**Hold Mode / Hold Period**

If required, hold processing can be applied by setting Hold Mode to "Peak" or "Valley" and setting the hold period. This is useful if the temperature reading is interrupted by gaps between moving objects (e.g. on a conveyor), or by an obstruction.

**LENS CLEANING**

Keep the lens clean at all times. Any foreign matter on the lens would affect measurement accuracy. Blow off loose particles (if not using the air purge accessory) with an air 'puffer'.

**TROUBLESHOOTING**

Symptom	Probable Cause	Solution
No output	No power to sensor	Check power supply and wiring
Inaccurate measured temperature	Target too small for sensor's field of view	Ensure the sensor's view is completely filled by the target. Position the sensor closer to the target to measure a smaller area.
	Target is a reflective metal surface	Use a lower emissivity setting, or measure a non-reflective area, or paint or coat a measurable area of the target to make it non-reflective
	Field of view obstruction	Remove obstruction; ensure sensor has a clear view of target
	Dust or condensation on lens	Ensure lens is clean and dry. Clean gently with a soft lens cloth and water. If problem recurs, consider using an air purge collar.
Communication error	Incorrect Modbus Slave Address	Check the Modbus Slave Address of the sensor and ensure it is set correctly in the Modbus Master

## PM180 TOUCH SCREEN INTERFACE MODULE

The PM180 is a temperature indicator, data logger, alarm unit and configuration tool for Calex infrared temperature sensors. It is compatible with all models in the PyroBus and PyroMiniBus series, as well as all PyroMini and FibreMini models with Modbus output.

The PM180 functions as the Modbus Master on an RS485 network of up to 6 temperature sensors, and can itself be connected as a slave device to another RS485 network via a second, isolated Modbus interface. This allows multiple PM180 units to be multi-dropped to create a large network of sensors and displays.

Optional alarm relay modules allow the PM180 to be connected to alarm equipment such as sounders and beacons, and optional analogue output modules allow it to be connected to non-Modbus instrumentation.

All the configurable parameters for the hub, the connected sensors and the optional output modules are adjustable via the PM180's built-in resistive touch screen interface, which can be operated even with gloves on.

With an optional MicroSD Card inserted, the PM180 functions as a fully-configurable data logger.



## SPECIFICATIONS

<b>Touch Screen Display</b>	2.83" (72 mm) resistive TFT, 320 x 240 pixels, backlit
<b>Supply Voltage</b>	10 to 30 V DC
<b>Maximum Current Draw</b>	100 mA
<b>Ambient Temperature Range</b>	0°C to 60°C
<b>Relative Humidity</b>	Maximum 95%, non-condensing
<b>Configurable Parameters (global)</b>	Temperature units, date and time, data logging, graph channels, alarm logging
<b>Configurable Parameters (per channel)</b>	Signal processing, emissivity setting, reflected energy compensation, alarms, Modbus address
<b>Alarm Configuration</b>	12 alarms (2 per sensor) with adjustable level, individually configurable as HI or LO.
<b>Temperature Units</b>	°C or °F selectable
<b>Temperature Resolution</b>	0.1° below 1000°; 1° above 1000°
<b>Signal Processing</b>	Average, peak hold, valley hold, minimum, maximum
<b>Display Sample Period</b>	120 ms per device (720 ms in total for 6 devices)
<b>Compatible Sensor Types</b>	PyroBus (all models), PyroMiniBus (all models), PyroMini (-BB and -BRT models), FibreMini (-BRT models)
<b>Compatible Output Module Types</b>	ICP DAS M-7061 12-channel relay output module, ICP DAS M-7024 4-channel analogue output module, selectable V/mA
<b>Dimensions</b>	98(w) x 64(h) x 36(d) mm excluding cable glands
<b>Weight</b>	280 g

## DATA LOGGING

With an optional MicroSD Card installed in the slot inside the PM180, data logging may be manually started and stopped via a button on the temperature display screen, or scheduled to begin at a pre-determined time via the Settings menu.

If the PM180 is connected via the slave interface to another Modbus network, logging may also be started remotely by the Modbus Master on that network.

## DIMENSIONS

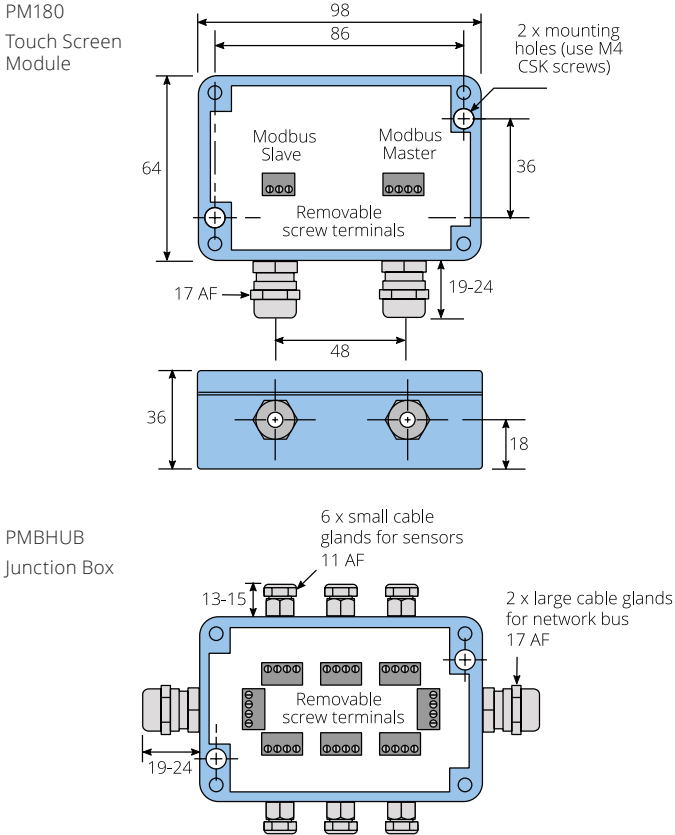

### PMBHUB JUNCTION BOX - SPECIFICATIONS

Construction	Die Cast Aluminium
Electrical Connections	Removable screw terminals, 28 AWG to 18 AWG
Weight	250 g
Environmental Rating	IP65

# ELECTRICAL CONNECTION

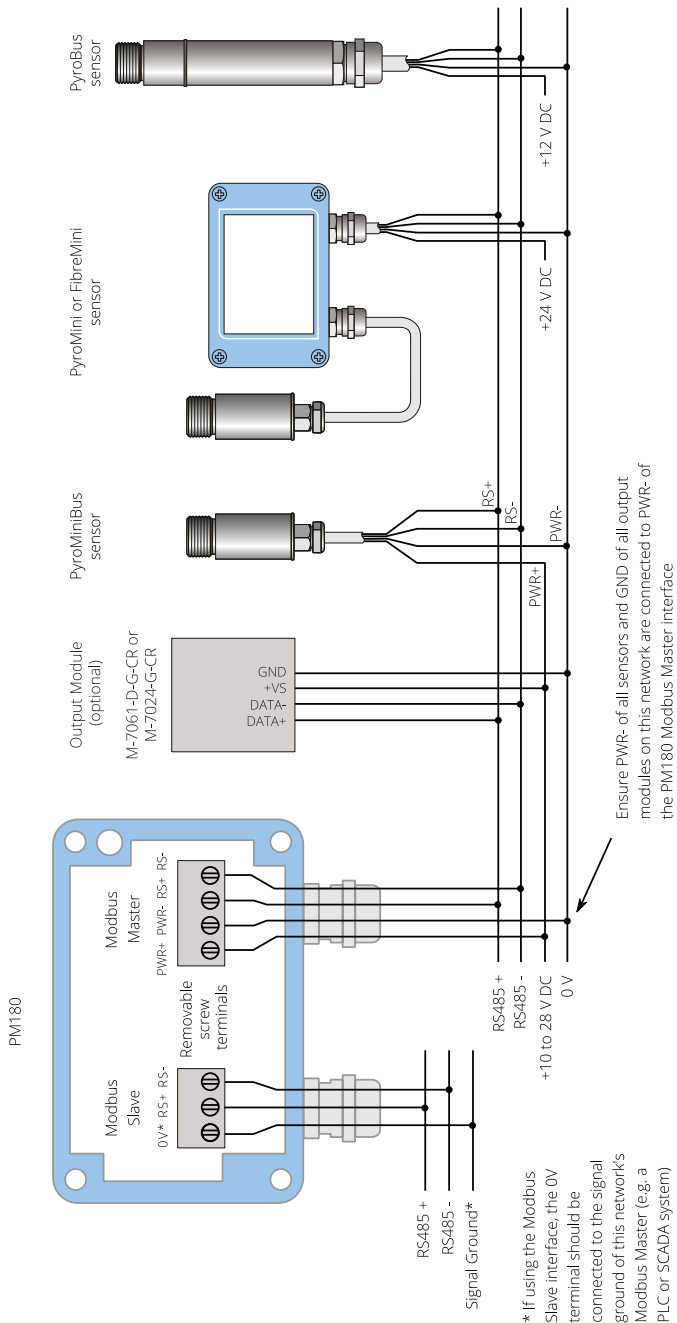

## **ELECTRICAL INSTALLATION**

The PM180 has removable screw terminal blocks for its Modbus Slave and Modbus Master interfaces.

- 1 Connect the Master interface to the sensors and output modules. Be sure to check the power supply requirements of each device before applying power.
- 2 Optionally, connect the Slave interface to another Modbus network with its own Modbus Master such as a PLC or SCADA system.

Isolation is provided between the Slave and Master interfaces.

Ensure the shielding of the RS485 network is continuous from the sensors to the Modbus Master. There should be only one possible path to ground from any point on the shielding. If necessary, introduce strategic breaks in the shielding (e.g. at junction boxes).

## **MICROSD CARD AND BATTERY**

The MicroSD Card and battery slots are located on the touch screen circuit board. Unscrew the lid of the PM180 to access them.

The battery is optional. With a battery fitted, the internal clock will continue to run when the power is off. Without a battery, the unit will request the date and time each time the power is cycled.

All other settings are stored in the unit's permanent memory and will be preserved when it is switched off, regardless of whether a battery is fitted.

## **USING THE TOUCH SCREEN INTERFACE**

Visit [www.calex.co.uk/PM180](http://www.calex.co.uk/PM180) for help on how to use the touch screen interface, including a diagram showing how to navigate to each setting and set up the optional output modules.

By default, the PM180 is locked and the Settings menu is greyed out. To access the Settings menu, unlock the PM180. The default password is 1234. After entering the password, tap the Unlock icon to unlock the unit. The password can be changed via the touch screen interface.

## **FIRST-TIME CONFIGURATION**

- 1 The first screen displayed on the PM180 is the Sensor List. The list is empty by default.
- 2 Tap "Add Device" to add a sensor.
- 3 Enter the Modbus address of the sensor to be added. The factory-set Modbus address is shown on a tag attached to the sensor.
- 4 Select the type of sensor and tap Apply (the green checkmark).
- 5 Repeat "Add Device" process for the remaining connected sensors and tap the Exit icon to start measuring temperatures.

## **CHANGING A SENSOR'S MODBUS ADDRESS**

Provided each Modbus address is unique, there should be no need to change the addresses of the connected sensors. If required, it can be done as follows:

- 1 On the PM180 interface, browse to Settings - Modbus Master - Sensor List
- 2 Tap the desired sensor to enter the Sensor Settings menu, then Modbus Address.
- 3 Enter the new Modbus Address for that sensor. The new address will be applied when the power is cycled.
- 4 Cycle the power.

If the changed sensor is no longer communicating with the PM180 (shown by a red temperature display), it is because the PM180 is still looking for the previous address. To resolve this, remove and add the sensor to the Sensor List:

- 1 Browse to Settings - Modbus Master - Sensor List
- 2 Tap the sensor that is no longer communicating, then tap Remove Device
- 3 On the Sensor List, tap Add Device and enter the Modbus address of the new sensor. Be sure to select the correct sensor type.

## MODBUS OVER SERIAL LINE (RS485)

INTERFACE		SUPPORTED FUNCTIONS	
Baud rate	9600	Read register	0x03, 0x04
Format	8 data, No parity, 1 stop	Write single register	0x06
Reply delay (ms)	20	Write multiple register	0x10

The list below includes all available addresses (R = Read, W = Write):

Address	Length (words)	Description	R/W
0x0000	1	MODBUS slave ID (slave address) of PM180	R/W
0x0001	7	Device identification string in ASCII	R
		"PM180vx.xx" where x.xx is the firmware version	
0x0008	2	Serial number	R
0x000A	2	Data acquisition sample interval (1 to 86400 seconds)	R/W
0x000C	2	Number of samples to be logged (0 to 86400 samples) - note: enter 0 to log continuously	R/W
0x000E	1	Data acquisition enabled (0 for disabled, 1 for enabled)	R/W
0x000F	1	Data acquisition start time: Hours (0 to 23)	R/W
0x0010	1	Data acquisition start time: Minutes (0 to 59)	R/W
0x0011	1	Data acquisition start time: Seconds (0 to 59)	R/W
0x0012	1	Data acquisition start time: Day (1 to 31)	R/W
0x0013	1	Data acquisition start time: Month (1 to 12)	R/W
0x0014	1	Data acquisition start time: Year (2012 to 2105)	R/W
0x0015	1	Alarm log settings	R/W
		Bit 0 - Log trigger time	
		Bit 1 - Log while triggered	
		Bit 2 - Log acknowledge time	
		Bit 3 - Log reset time	
0x0020	1	Remote request - Start logging	R/W
		Write 1 - request start of data logging	
		Read 1 - request pending, Read 0 - no request pending	
0x0021	1	Remote request - Stop logging	R/W
		Write 1 - request termination of data logging	
		Read 1 - request pending, Read 0 - no request pending	
0x0022	1	Remote request - Acknowledge alarms	R/W
		Write 1 - request acknowledgement of alarms	
		Read 1 - request pending, Read 0 - no request pending	
0x0023	1	Remote request - Reset alarms	R/W
		Write 1 - request reset of alarms	
		Read 1 - request pending, Read 0 - no request pending	

### NOTES:

- 1 For further information please refer to <http://www.modbus.org/specs.php>
- 2 Use address 255 to communicate with any connected unit (only one sensor connected)
- 3 Use address 0 to broadcast to all connected units (no response expected)

## ACCESSING CONNECTED SENSORS VIA ANOTHER MODBUS MASTER

If the PM180 is connected to another Modbus Master, such as a Modbus PLC or SCADA, the entire sub-network (the PM180, the connected sensors and output modules) appears as a single Modbus Slave device to the PLC or SCADA. The Modbus Slave ID (Modbus Address) is that of the PM180.

The temperatures and settings of the sensors connected to that PM180 can be read by adding the following offsets to the sensor's own Modbus register addresses. The Sensor Index is the position of the sensor in the PM180 sensor list. The Sensor Index numbers correspond to the positions of the sensors on the PM180 screen as follows:

0	1
2	3
4	5

Sensor Index	Address offset (hex)	Address offset (decimal)
0	0x1000	4096
1	0x1100	4352
2	0x1200	4608
3	0x1300	4864
4	0x1400	5120
5	0x1500	5376

### Example

To read the Filtered Temperature on a PyroMiniBus sensor in position 4 on the PM180 as shown above, read from register  $0x0E + 0x1400 = 0x140E =$  decimal 5134.

For information on the Modbus addresses for other compatible sensors, please see the Operator's Guide for that sensor.

## MAINTENANCE

Our customer service representatives are available for application assistance, calibration, repair, and solutions to specific problems. Contact our Service Department before returning any equipment. In many cases, problems can be solved over the telephone. If the sensor is not performing as it should, try to match the symptom below to the problem. If the table does not help, call Calex for further advice.

## GUARANTEE

Calex guarantees each instrument it manufactures to be free from defect in material and workmanship under normal use and service for the period of two years from the date of purchase. This guarantee extends only to the original buyer according to Calex Terms and Conditions of Sale.

