

HUTX1-485

Temperature and Humidity Sensor

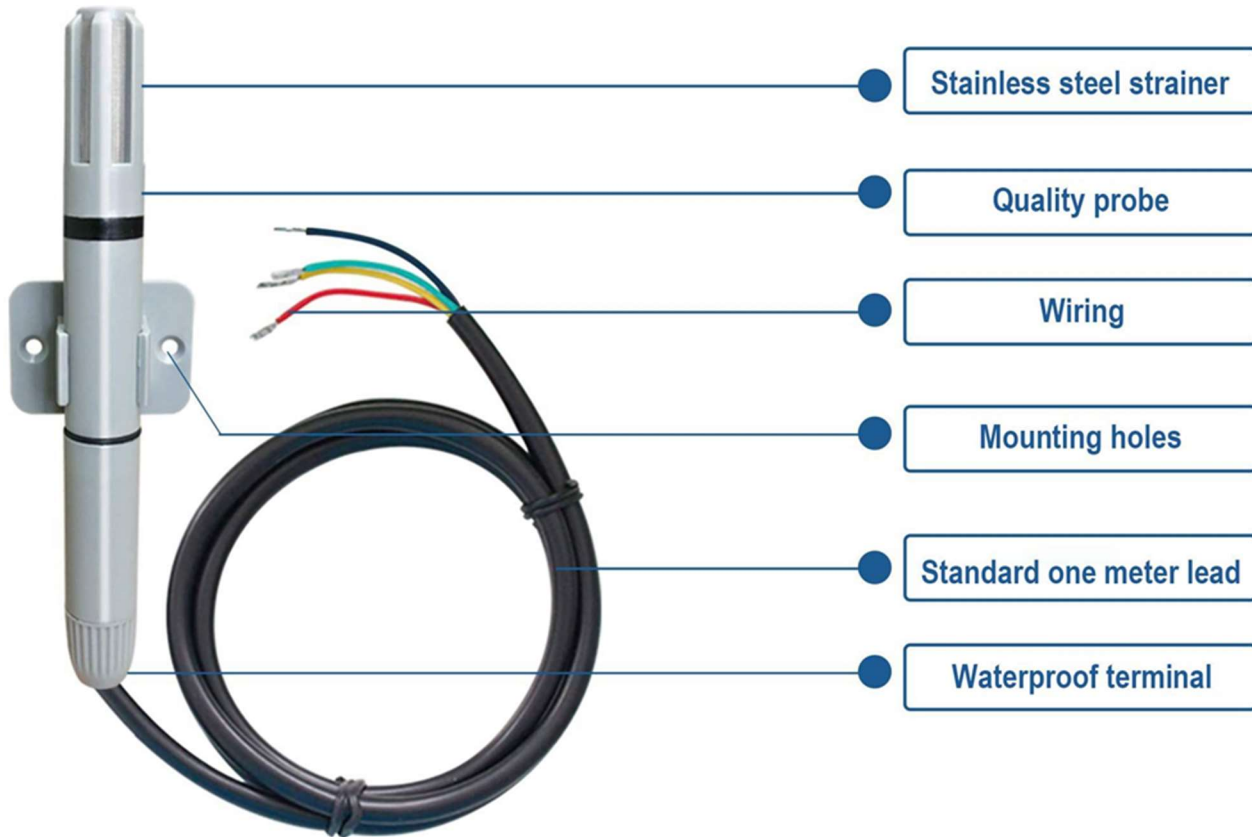

Revision V1.0

© Copyright 2023 IOThrifty LLC. All rights reserved. This document may not be copied, photocopied, reproduced, translated, or reduced to any electronic medium or machine-readable form, in whole or in part, without the prior written consent of IOThrifty LLC

Product Overview

The HUTX1-485 temperature and humidity sensor with RS-485 communications using Modbus-RTU protocol allows it to be connected to the Modbus network for temperature and humidity measurement and monitoring.

The HUTX1-485 is designed around the SHT3X, a newly designed and improved capacitive humidity sensor which provides greatly improved performance over the previous generation of sensors (SHT1x and SHT7x) in high humidity environments.

Setting the Modbus address of HUTX1-485 is done via DIP switch, which avoids the need to set the address by computer or PLC. It is simple and convenient to maintain and replace.

The HUTX1-485 has excellent long-term stability, low latency, low power consumption, good resistance to chemical contaminants and excellent repeatability. It is used for accurate temperature and humidity measurement in HVAC, communication equipment rooms, warehouse buildings, and automatic control applications.

Features

- Low power consumption
- Fully calibrated
- High precision and good repeatability
- Long-term stability, low drift
- Humidity full range temperature compensation
- Standard Modbus-RTU protocol

Application Uses

Generally used in indoor clean environments, such as:

- HVAC
- Building automation
- Laboratory, hospital, library, museums
- Storage and production facilities in the pharmaceutical, paper, food and electronics industries

Power supply

Supply voltage	5 to 24 Vdc
Current	5mA

RS-485 interface

Transmission rate	Optional 4800bps / 9600bps / 19200bps
-------------------	---------------------------------------

Transmission distance

The maximum transmission distance is about 1200 meters depending on the use environment, transmission material and transmission rate

Number of theoretical nodes	32
-----------------------------	----

Temperature measurement

Sensing element	SHT3X
Working range	-40 to 85°C
Resolution	0.1°C
Measurement accuracy	±0.2°C

Humidity measurement

Sensing element	SHT3X
Working range	0 to 95%RH
Resolution	0.1%RH
Measurement Accuracy	± 2%RH
Hysteresis	< ±0.8%RH
Response time	About 8s (from 33%RH to 75%RH, in flowing air)
Long-term stability	<±0.25%RH/year (under no pollution)

Lead cable

Lead	Label	Function description
Green	B-	RS485 interface B-
Yellow	A+	RS485interface A+
Black	GND	Common ground (connect to the negative end of the power supply when DC power is supplied)
Red	V+	Power supply positive (connect to the positive end of the power supply when DC power is supplied)

RS485 wiring diagram

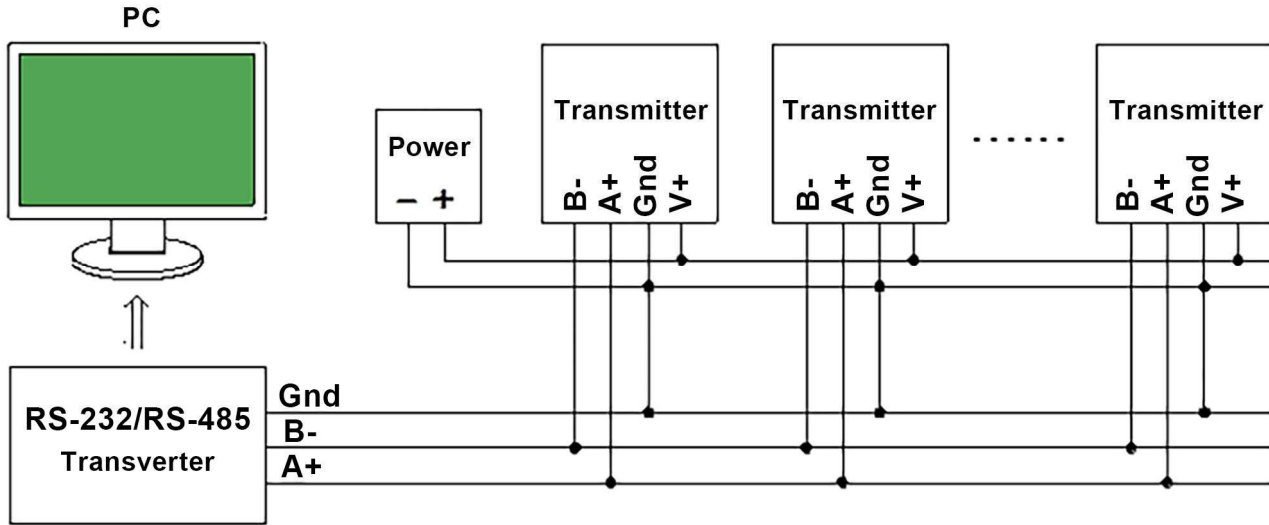

Wire Note:

When setting up an RS485 network, pay attention to the RS485 grounding to eliminate the common mode voltage. It is suggested to connect the common ground of each sensor together, and then connect it to the ground wire of the RS-232/RS-485 transverter.

To connect, you can use the shielding layer of the shielded wire as the ground.

DIP switch and address setting



Note: The above picture is a diagram of the DIP switch. The DIP switch has 8 DIP positions. The corresponding numbers from 1 to 8 are 128, 64, 32, 16, 8, 4, 2, 1, and these values are added together as the address code. As shown in the figure above, bits 1, 3, and 4 are in the ON position, so the address code $128+32+16=176$, that is, the address code 176

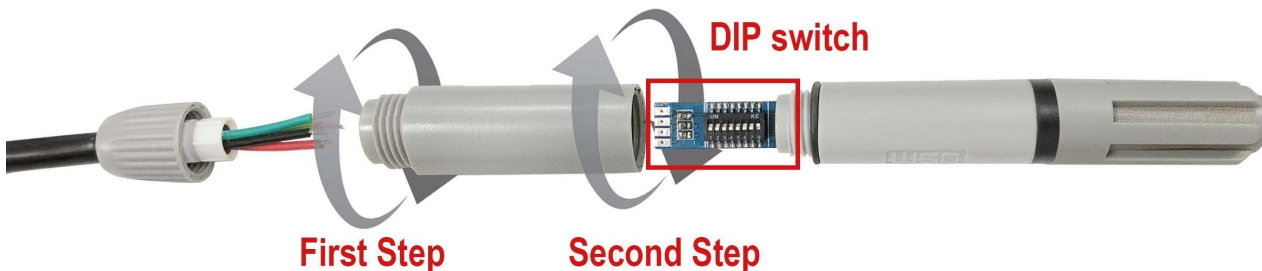

The above figure is a diagram of the correct steps to open the sensor body to expose the DIP switch.

Protocol

This document contains only the information relevant for the HUTX1-485 regarding the Modbus protocol. There are many other sources available on the internet which provide more detailed information about Modbus RTU protocol.

Data frame format

Start bit	Data bit	Parity bit	Stop bit
1	8	0	1

Note: The above is the default format of the sensor. If you need a different format, it may be available as a custom order. Please contact IOthriftly for details.

RTU message frame format

HUTX1-485 follows the Modbus RTU frame protocol. To ensure the integrity of the information, a pause time of 3.5 characters or more is required at the beginning and end of each frame (T1-T2-T3-T4), each byte of the information frame needs to be transmitted continuously. If there is a pause greater than 1.5 characters, the sensor will treat it as invalid information and will not respond.

Information frame format

Start	address	function code	Data area	CRC check	end
T1-T2-T3-T4	1byte	1byte	- 5 -N byte	2byte	T1-T2-T3-T4

Register Descriptions

Register Address	Meaning	Description	Read and write
0	Temperature	The unit is 0.1 degree,MSB. First, complement format, 7FFF H means error condition.	Read only
1	Relative humidity	The unit is 0.1%, MSB First, complement format, 7FFF H means error condition	Read only
2	Reserved 1		Read only
3	Reserved 2		Read only
4	Address code	Set by DIP switch	Read only
5	Baud rate	Support 4800、9600、19200	Can read and write
6	Hardware version		Read only
7	Software version		Read only

Address setting

The default setting is 1, user modifiable by dip switch.

Baud rate setting

The default setting is 9600, can be set via software.

Host request sensor information example (function code 03)

Request data using function code 03 to read the temperature and humidity measurement value of the sensor and other information. The information frame format of the 03 code is as follows :

Host request information frame

Field Description	Example
Slave address	01
Function code	03
Register address high byte	00
Register address low byte	00
High byte of query quantity	00

Sensor response information frame

Field Description	Example
Slave address	01
Function code	03
Return the number of bytes	10
Temperature data high byte	00
Temperature data low byte	FA
Humidity data high byte	02
Low byte of humidity data	58
1 high byte reserved	00
1 low byte reserved	00
2 high byte reserved	00
2 low byte reserved	00
Address code high byte	00
Address code low byte	01
Baud rate high byte	25
Baud rate low byte	80
Hardware version high byte	06
Hardware version low byte	00
Software version high byte	00
Software version low byte	0A
CRC check code low byte	D4
CRC check code high byte	64

Data explanation

Temperature = 00FAH = 250 / 10 = 25.0°C ; Humidity = 0258H = 600 / 10 = 60.0%RH ; Reserved 1 = 0000H; Reserved 2 = 0000H; Address code = 0001H = 1; Baud rate = 2580H = 9600; Hardware version = 0600H; Software version = 000AH = 10 = V1.0;

Note! If users only want to read the temperature and humidity or other registers, they only need to read the corresponding registers.

Host setting sensor information example (function code 06)

Setting the sensor baud rate (register address is 0005H), and the message frame format is as follows:

Host request information frame

Field description	Example
Slave address	01
Function code	06
Register address high byte	00
Register address low byte	05
Set value high byte	25

Sensor response information frame

Field description	Example
Slave address	01
Function code	06
Register address high byte	00
Register address low byte	05
Set value high byte	25

Error response

When the host sends request information to the sensor, various errors may occur. At this time, the sensor sets the highest position of the function code to 1, and then returns an error code. The host can determine whether an error has occurred by detecting whether the highest bit of the function code is 1.

Return format

Slave address	Function code	error code	CRC check
1 byte	1 byte	1 byte	2 byte

Error code

- 01 : Illegal function code
- 02 : Illegal data address
- 03 : Illegal data value

CRC check code

Modbus RTU mode uses CRC-16 check, the check code occupies 2 bytes. If the check code is wrong, the sensor will ignore the host's request and not respond.

The calculation method of CRC-16 check code is as follows:

- ① Preset a 16-bit register as hexadecimal FFFF, call this register CRC register;
- ② XOR the first 8-bit binary data (the first byte of the information frame) with the lower 8 bits of the 16-bit CRC register, and place the result in the CRC register;
- ③ Shift the content of the CRC register one bit to the right (toward the low bit) and fill the highest bit with 0, check the right shift out position after shift;
- ④ If the shifted out bit is 0, repeat step ③ (shift one bit to the right again), if the shifted out bit is 1, the CRC register is XORed with the polynomial A001 (1010 0000 0000 0001);
- ⑤ Repeat steps ③ and ④ until the right shift is 8 times, so that the entire 8-bit data has been processed;
- ⑥ Repeat steps ② to step ⑤ to process the next byte of the message frame;
- ⑦ After calculating all the bytes of the information frame according to the above steps, the content of the CRC register obtained is: 16-bit CRC check code.

Dimensions (unit: mm)



Warranty Terms

IOThrifty LLC ("IOThrifty") warrants that for a period of one year following delivery, the IOThrifty products you have purchased will (a) perform in accordance with published specifications, and (b) will be free from defects in materials or workmanship. In the event an IOThrifty Product does not meet this warranty, subject to the conditions set forth in these terms and conditions, IOThrifty's sole obligation will be, at its election, to repair or replace the product in question or to refund the purchase price.

IOThrifty MAKES NO OTHER WARRANTIES, EXPRESS OR IMPLIED, AND ALL IMPLIED WARRANTIES OF MERCHANTABILITY, NON-INFRINGEMENT AND FITNESS FOR A PARTICULAR PURPOSE ARE HEREBY DISCLAIMED. IN NO EVENT WILL IOTHRIFTY BE LIABLE FOR PUNITIVE, SPECIAL OR CONSEQUENTIAL DAMAGES, OR FOR AN AMOUNT IN EXCESS OF THE PURCHASE PRICE OF THE DEFECTIVE IOTHRIFTY PRODUCT OR PRODUCTS.

This warranty will not apply to any IOThrifty Products that have been (a) damaged by lightning, water, or power surges, (b) neglected, altered, abused, or used for a purpose other than the purpose for they were provided, (c) repaired by you or any other party without IOThrifty's prior written authorization, (d) used in conjunction with a third party product or products not approved in advance by IOThrifty, or (e) otherwise used in a manner inconsistent with any instructions provided by IOThrifty.

Customer Service and Technical Support

Contact IOThrifty's Customer Service Department for support, return or repair information. Email: service@IOThrifty.com, Telephone: (860) 733-1117

Copyright

© Copyright 2023 IOThrifty INC. All rights reserved. This document may not be copied, photocopied, reproduced, translated, or reduced to any electronic medium or machine-readable form, in whole or in part, without the prior written consent of