



OPERATING MANUAL

Fluidized Temperature Bath

Model FTBSL6



TABLE OF CONTENTS

Introduction	3
Warnings & safety	4
Installation	5 & 6
Specifications	7
Operation	8
Fault finding & maintenance	10
Parts list	11
Wiring Diagrams	12
EC Declaration of Conformity	13

INTRODUCTION

Fluidized Temperature Baths have been in use for decades as a temperature source for many heating applications such as thermal cleaning, heat treatment, calibration, thermal analysis, process heating and laboratory reactive heating. It is important that this instruction manual be made available to all operators who may come in contact with the system. All operators should read this manual from beginning to end and observe all safety warnings and symbols. In particular, we would stress the importance of standard, commonsense rules and adherence to normal, safety standards and procedures. Maintenance and/or service should only be performed by a qualified electrician or engineer. **If there is any doubt whatsoever relating to the proper use of this equipment, please contact us.**

The Fluidized Temperature Bath consists of a stainless steel tank and top cover that is surrounded by a powder coat painted outer case. This tank either contains or is surrounded by electrical heating elements and is wrapped with an insulation blanket. Temperature and air control systems as well as other electrical components are housed within control cabinet that is mounted on the side. The temperature of the fluidized temperature bath is set and maintained by temperature controller, which receives an electrical signal from a type "K" thermocouple placed along the fluidized bath container inner wall. Current to the heating elements is switched on and off by means of solid state relay actuated by the temperature controller. The controller resolution is 1° and can be switched between °C and °F.

The systems are supplied with independent over-temperature protection via a 2nd thermocouple junction that will disable power to the heaters in the event that one of the following conditions occur; thermocouple failure, loss of power to or controller fault and/or exceeding the factory set high temperature limit of 618°C(1145°F). The controller will flash a message when one of these conditions has occurred and/or light up the front panel neon light labeled "Overtemp".

Air enters into an air chamber in the bottom of the tank that causes the aluminum oxide to Fluidize. The air supply to the Fluidized bath must be clean and dry and adjusted to supply a constant 30 PSI/2.0 bar of pressure at a maximum flow of 1.76cfm/50lpm. An air filter and pressure regulator can be supplied as optional equipment part # ATS1026. Air flow to the Fluidized Bath is controlled automatically by 3 solenoids which are connected to 4 needle valves to set and control air flow at various temperature points. Controller display LED's SUB1, SUB2 and SUB3 are used to control air flow and are not indicative of any fault condition.

WARRANTY & USE DISCLAIMER

This product is covered by a 1 year parts and labor factory warranty. It must be clear that **Accurate Thermal Systems** and our suppliers are not insuring your products/premises or guaranteeing that there will not be damage to your person or property if you purchase our Products. **Accurate Thermal Systems** or our Suppliers shall not be liable under any circumstances for damage to your person or property or some other person or that person's property by reason of the sale or use of the product we sell, or its failure to operate in the manner in which it is designed. **Accurate Thermal Systems** and our Suppliers liability, if any, shall be limited to the original cost of the Product only. Use of this Product is at your own risk. Buyer assumes full responsibility in determining the suitability of these items for buyers intended use. It must be clear that the Warrantors are not insuring your products/premises or guaranteeing that there will not be damage to your person or property if you use products purchased from **Accurate Thermal Systems**. **WARRANTORS' OBLIGATION UNDER THIS WARRANTY IS LIMITED TO REPAIR OR REPLACEMENT OF THE PRODUCT ONLY. THIS WARRANTY DOES NOT COVER PAYMENT OR PROVIDE FOR THE REIMBURSEMENT OF PAYMENT FOR INCIDENTAL OR CONSEQUENTIAL DAMAGES.**

WARNINGS AND SAFETY

Please read this entire manual before operating the Fluidized Temperature Bath. If used improperly a serious personal injury can occur and/or cause damage to the system. Our products are designed and manufactured to conform to internationally recognized safety standards and requirements. Accurate Thermal Systems, its representatives, vendors and distributors assume no liability for the operation of this product in an unsafe manner. Use common sense and adhere to all warnings and cautions during use.

High temperatures can cause serious burns and ignite combustible materials. Please be aware of and conform to the following. The symbols shown may appear in this manual or on the product.



WARNINGS

- **WEAR PROTECTIVE GLOVES** that are rated for 1000°F/525 °C that cover your hands and arms up to the elbow
- **DO NOT** use the system near flammable liquids or gases
- **Provide at least 12”/305mm** of open space around the system and 4 ft/1200mm above it to prevent surrounding objects from getting hot.
- After removing parts, baskets and any other heated items from the system remember that they may be **VERY HOT**
- **Never add cold aluminum oxide sand** to the Fluidized Bath when it is above 300°F/150 °C
- **Eye goggles** that are not vented should be worn when working with the system to protect eyes from heat and aluminum oxide sand

CAUTION

- **DO NOT** use the Fluidized Bath if the control box vents are blocked
- **DO NOT** operate the system if it is not Fluidizing/bubbling or it appears that a portion is not Fluidizing as normal
- **DO NOT** place any fluids or liquids directly into the bath
- **DO NOT** use the Fluidized bath if the surrounding area or floor becomes wet
- If the “**OVERTEMP**” light comes on, **DO NOT** shut off power but instead contact maintenance or a qualified technician immediately.
- In the event of a power loss leave the air supply on and flowing if possible

PACKAGING, HANDLING & TRANSPORTATION

Inspect all shipping containers for signs of damage which may have been caused by rough handling in transit. Immediately take pictures of any damage to the packing. If the packaging is damaged carefully unwrap all items to inspect for damage. Also take pictures of any damaged product and then immediately contact the Freight Company and Accurate Thermal Systems.

Remove the packing list and verify that all ordered items have been received. If there are any questions about the shipment, please call Accurate Thermal Systems at (609) 326-3190.

Retain the cartons in which the bath was received until the unit is tested and found to be in good condition. When transporting a system it must be padded and packed in a box to prevent damage.

INSTALLATION



General
Caution

1. The bath should be placed in a location that is level and dry. Check the system for levelness. It should be located in an area where suitable power and air are available.
2. Due to the radiated heat from the system install in a location that allows at least 12"/30cm of clearance on the sides and 4ft/120cm above to prevent surrounding objects from getting hot.
3. Connect an air supply set to deliver a constant 30 PSI/2.0 BAR at maximum flow of 1.76 cfm/50 lpm. The air supply should be dry and free of particulate. A must be flowing and set at 30 PSI at all times when the bath temperature is above 200°C/400°F or damage can occur. **An air supply that is not dry can cause damage to the system and/or components that are immersed into it.** Contact us for assistance with air filtering and drying. A 6ft/180cm length of 3/8"/10mm OD rigid tubing should be used to connect the air supply to the bath via the quick disconnect fitting on rear of the control box.
4. Before connecting to your electrical supply verify that it meets the **VOLTAGE RATING** and requirements for the unit as shown on the rating plate. **The requirements below must be met to maintain safety to both equipment, personnel and property. ALL ELECTRICAL CONNECTIONS MUST BE MADE BY A QUALIFIED ELECTRICIAN OR ENGINEER.** The system is supplied with a 6ft/183cm length power cable for each specific model. Below are recommended wire sizes for the power feed up to the breaker panel and the recommended breaker ratings.

Model	Supply conductor size to breaker panel – 300 volt rating	Switchable panel breaker rating
FTBSL6 – 120VAC	12 gauge or 3.31mm ²	20 amps/ 250 VAC
FTBSL6 – 240VAC	12 gauge or 3.31mm ²	10 amps/ 250 VAC
Fluidized Bath wiring connections		
Live	Black/Brown	
Neutral	White/Blue	
Green	Earth (PE)	



Electrical
Shock
Caution

The system requires a single phase, 50/60hz supply that is capable of delivering between 110 and 120 VAC under load at the rated current. For the 240VAC model the supply voltage should be between 220 and 240VAC. A supply below 108VAC (120VAC systems), 215VAC (240VAC systems) under load is too low and can cause component damage and increase heat up times.

5. Fill the bath with Aluminum oxide sand to within 4"/10cm of the top cover adhering to safety guidelines on page 2. Immersed parts and objects may displace the aluminum oxide causing it to rise and it also expands with heat so adjust accordingly at your operating temperature.
6. Turn on power and air to the unit, set power switch to 1 which is on, 0 power switch is off. Use the up and down arrows to set the controller to your operating set temperature. The  button can be used to select digits for fast changing. When Fluidized and bubbling make sure the Aluminum oxide sand level is maintained per step 5. Air must be flowing to the bath at all times when the temperature is above 150°C/300°F.
7. The green heater neon will light up when power is applied to the heaters.
8. **IMPORTANT:** Once the controller has reached your set temperature and the heater light is flashing *ALLOW 15 MINUTES* for the bath to fully stabilize before use.
9. NOTE: LED's ALM1, ALM2 & ALM3 on the temperature controller are used for air control and are not indicative of a fault.
10. **IMPORTANT:** Use caution when removing the lid with handle from the bath as it is **very hot and will cause burns on contact.**
11. The bath air supply and power can be turned off for safe shutdown after the temperature has cooled to 150°C/300°F

TECHNICAL SPECIFICATIONS

Overall external dimensions:	length: 13" (330mm) width: 17" (432mm) height: 16" (406mm)
Bath internal dimensions:	5.3" (134.6mm) diameter 7.0" (178mm) deep
Working volume:	5.3" (134.5mm) diameter 7.0" (178mm) deep
Temperature range:	50°C to 605°C (122°F to 1121°F)
Temperature stability:	±0.3° C from 100 to 600°C after 15 minutes Dead bed stability, +/-0.015° for a 5 minute period
Calibrated accuracy:	±2.0° C thru the operating range (5" immersion depth)
Heat up time*(minutes):	Ambient to 300°C – 24, to 450°C – 42, to 600°C – 70
Loading/quench effect:	A 1 lb (0.45kg) mass quenches the bath by 7°C and 2 lbs (0.9kg) by 11°C (at 450°C) To extend heater life we recommend no more than a 1.5 lb load.
Air supply:	Clean, dry and oil free air supply, at a fixed and constant pressure of 30 psi/2.1 bar, max flow of 1.76 CFM (50 lpm) using a 3/8"(9.5mm) OD rigid tubing plugged into the quick release fitting on the control box.
Fluidizing bath media:	Aluminum oxide 13 lbs. (5.9kg)
Electrical requirements:	120V, 1 phase, 60Hz, 1920W, 16 amps or 240V, 1 phase, 60HZ, 1920W, 8 amps
Gross weight:	52 lbs. (23.6 kg)
Net weight:	FTBSL6 - 32 lbs. (14.5kg) Aluminum oxide - 20 lbs (9kg)

* Indicated heat up time applies for a well fluidized bath with a lid on, power supply voltage of 110 to 120 VAC under load. (220 to 240 VAC if configured for 240 VAC operation)

Note that a supply voltage below these values can damage the solenoid valves and reduce heat up time and bath performance.

OPERATION

The FTBSL Fluidized baths in this manual were designed specifically for heat treatment, reactive chemistry, calibration and exothermic reaction type of applications. Fixtures, devices and apparatus can be mounted and suspended from the included lid for immersion into the bath. The systems have been designed with sufficient heat capacity to minimize quenching when objects are immersed depending on the mass of the item. The Fluidized Temperature Bath and aluminum oxide media used in the system is not abrasive to immersed objects.







The unique bath cover and lid have been developed to minimize media loss out of the top of the system. It is recommended that the lid with handle be kept on the bath at all times to contain media and heat.

BATH TEMPERATURE

The bath should be allowed to stabilize for at least 15 minutes after the controller has reached the set point temperature before using the bath. An initial temperature drop or quenching of the bath can occur after inserting objects into the bath. This temperature drop depends on the size of the immersed object, but is generally in the order of 5 to 7°C. Air and electrical power to the Fluidized Bath can be shut off once the system cools down to the safe temperature of 150°C/300°F.

PID TEMPERATURE CONTROLLER

The control parameters in the PID temperature controller have been optimized by the factory to give the best results for most applications.

- 1) To change the set point use the up/down buttons to set a value. The  key can be used to switch between display digits for fast set point changes. Press  to accept any changes.
- 2) The controller has been locked out to prevent accidental parameter changes. This is confirmed by the key symbol  in the display.
- 3) To unlock the controller press the  key and the down arrow at the same time. The display will show **KEYP**. Use the up arrow to select all zeros 0000 and then press .
- 4) To lock out the controller, press the  key until **LoC** is displayed. Use the up arrow to select **LoC2** and then press .
- 5) When the controller is unlocked use parameter **PVoF** to make adjustments to the bath calibration as measured by an independent reference thermometer with suitable accuracy.

OPERATOR BASIC MAINTENANCE

The aluminum oxide, not being degradable, will only require replacement when losses occur due to attrition, spillage or when becomes contaminated with carbon and ash.

The optional air-line filter/regulator (ATS1026) into the bed is self-draining. However, it should be kept in good condition by inspection at four week intervals and by cleaning the bowl and washing or replacing the filter element as necessary. With exceptionally dirty or wet air supplies this frequency may have to be increased. In addition, oil vapors in the air supply which reach the fluidizing plate are carbonized within the pores of the plate, quickly causing blockage and consequent poor fluidization. Oxidation of immersed parts and objects could occur if an air supply with high moisture content is used to Fluidized the bath. When parts are removed from the bed, they should be allowed to safely cool before handling. If the bath is left unused for long periods of time, empty the aluminum oxide and store it in a separate container. Keep the inside of the bath clean and dry.

PLASTIC THERMAL CLEANING PROCESS

When burning off plastic and other polymers from parts the first two thirds of the total time required for tool cleaning, the plastic is reduced to a tar mix state. In this phase, all the initially combustible products of the plastic leave the bath through an appropriate fume extraction system. In the last third of the immersion time, the tar mix state is reduced to carbon which either burns away or remains loosely bound to the tool. After the parts have been removed from the Fluidized Bath and safely cooled off they can be blown off with shop air or lightly brushed off with a wire brush or Scotch Brite pad to remove any loosely bound ash and/or sand. In some cases, dies may need to be wiped off or polished gently with a soft cloth. To minimize oxidation of tooling made from tool steel we recommend spraying them down with Slide Mold Shield dry rust preventive after they have cooled down. It can be purchased at the following website link: <http://slideproducts.com/cgi-bin/product.cgi?skucat=429>

The aluminum oxide fluidizing medium is not degradable but will need to be replenished due to loss during operation or extracted in the exhaust. We suggest replenishing or replacing the bath with new aluminum oxide sand with new every 4 to 6 months when cleaning tooling. In the particular case of PVC, chlorinated hydrocarbons remain in the fluidized bath after burn off which dictates special maintenance procedures. When removing PVC we recommend leaving the system to run at lower temperatures (100°C/200°F) when not in use to minimize moisture ingress into the aluminum oxide which can increase Hydrochloric acid levels in the bath resulting in oxidation and damage to metal components.

TYPICAL CLEANING TEMPERATURES

The following table details recommended operating temperatures for particular Polymers. The temperatures quoted should be used as an *initial starting guide only*. The ideal operating temperature will vary depending on the size of the parts, amount of material being removed and any particulars of the polymer being removed. Temperatures below 400°C/750°F should be avoided to eliminate the danger of the polymer melting and sinking to the bottom of the bath where it may block the porous plate. With large objects it may be desirable to heat the bath to above the operating temperature so that the polymer rapidly moves through the melting phase to the burning condition. Excessive operating temperatures should be avoided as they increase the fume concentration and may result in a flame up of the parts in the bath. In most cases when no more smoke is emitted from the bath allow 10 more minutes to pass and then pull the basket out to see how things look. Start with 1 or 2 parts first to determine your optimum cleaning temperature. Following the above, after a few cleanings you'll have a good recipe worked out.



Use as a guide & starting point only. Always use the lowest temperature that gives satisfactory results

Material Burn-off temperature °C/°F

Nylon 450/842	Paint 475-575/887-1067	Styrene 450/842
Polyethylene 425-450/797-842	Polypropylene 425-500/797-932	Flouropolymers, FEP, etc up to 550/1025
PTFE up to 525/950	PVC 460-540/860-1004	High density polythene 450/842
PEEK 550/1025	Silicone Rubber 535/995	Polyesters 450/842
Ethylene methacytic 450-480/842-896	Polyurethane 440-450/824-842	Polystyrene 450/842
Rubber debonding 350/662	Polycarbonate 400-425/752-797	Organic matter oil/grease 300-500/572-932
Crosslink PE 400/750		

FAULT FINDING & MAINTENANCE

Fault finding, electrical troubleshooting and maintenance should only be performed by **qualified electrician or service engineer**. Always make sure the power supply is disconnected with a lockout notice in place before replacing parts. Refer to the spares list on the next page and wiring diagram to troubleshoot for any parts that are required.

 	1. Poor or no Fluidization – remove aluminum oxide from bath leaving approximately 1 inch in the bottom. If an area ¼ or more is not bubbling then most likely the porous plate is blocked and should be replaced. Check that the porous plate is not blocked with plastic residue or other material. Verify air supply is set to 30 PSI. If OK, see step 10.
	2. Slow heat up – Check current draw of the heaters. The 120volt model should be around 16amps, 240volt models should measure 8 amps. Also verify that the bath is Fluidized and bubbling well.
	3. Thermocouple fault – if the “S.ERR” alarm is shown on the controller, check with an ohmmeter to see if you have continuity. If open then replace the thermocouple
	4. “OVERTEMP” light is on - indicates that an over temperature condition has occurred or the limit thermocouple has failed. First verify that air is flowing into the bath and that it is well fluidized using an air flow meter to verify flow rates shown in the table below. Next check to see that the thermocouple connected to the open PCB limit controller on pins 3 & 4 has not failed. Finally make sure that the solid state relay passes current only when a DC signal is output by the controller. The fault condition can be cleared by shorting terminals 1 and 2 (top left side) on the limit control PCB.
	5. No heat – verify heater current. 120 VAC model should measure 16 amps and the 240 VAC 8 amps. If no current check heater resistance, 120 VAC = 7.5 ohms, 240 VAC = 30 ohms. If OK go to step 6.
	6. Defective SSR – the controller will output a DC signal to the SSR (OUT1) when heat is called for. If the solid state relay is receiving a DC control signal but not passing power to the heaters then it should be replaced. If OK, go to step 7
	7. Failed power relay – verify that the relay coil has voltage across it and that the contacts are closing. If power is not passing through the relay contacts it should be replaced.
	8. Bath temperature is not accurate – if you suspect that the bath temperature is off it can be checked with a calibrated temperature probe and meter. Do not use an IR thermometer to measure the sand temperature. If inaccuracy is verified refer to step 1 and 2. If OK the control thermocouple should be checked and replaced is necessary.
	9. No controller display – check the fuse on the back of the control box.
	10. Flow rates not meeting table below – verify that the 3 solenoid valves are receiving power from the controller and replace as necessary. To check air flow rates an analog or digital flow meter will need to be put in series with the inlet air supply.

FLUIDIZING AIR ADJUSTMENT

The system automatically controls the Fluidizing Air to the bath at all times. It is a very reliable and flexible setup however the user can make adjustments to optimize the Fluidization as needed. The controller is set up with factory defaults to give satisfactory results based on the temperatures and flow switch points shown below. In general it is always preferable to be over-Fluidized than under.

<u>Indicated bath temperature</u>	<u>Alarm LED</u>	<u>Needle Valve</u>	<u>Flow rate – LPM</u>
up to 174°C (345°F)	ALM1, ALM2, ALM3	1, 2, 3, 4	45
175°C (347°F) to 324°C (616°F)	ALM2, ALM3	1, 2, 3	31
325°C (617°F) to 434°C (813°F)	ALM3	1, 2	26
435°C (815°F) to 605°C (1121°F)	None	1	20

SERVICING and TECHNICAL ADVICE

We are always available to discuss particular applications or service inquiries. Complete servicing and repair of all Accurate Thermal Systems products are available at our factory.

Accurate Thermal Systems
4104 Sylon Blvd
Hainesport, NJ 08036
Ph: 609-326-3190
Email: service@accuthermal.com

SPARE PARTS

A list of spare parts is provided below. For clear identification, please refer to the part number as well as the item description. Please contact us for assistance and support

<u>120 volt Model</u>	<u>Description</u>	<u>240 volt model</u>
4317	1/16 DIN PID Controller	4317
4305	1140F open PCB limit controller (S/N: 1533-814 & up)	4240
BD158	Inner Tank	BD158
AD155	Heater, 120V, 1ph, 640W (3 /unit)	n/a
n/a	Heater, 240V, 1ph, 640W (3 /unit)	AD179
AD161	Porous Plate	AD161
CD160	Air chamber assembly	CD160
4191	25 amp SSR	4191
4327	Type K Thermocouple, dual junction	4327
4307	30amp power relay	4334
4293	Fuse – 18 amp, 120V model	n/a
n/a	Fuse – 10 amp, 240V model	4312
4116	Fuse holder	4116
4304	Thermocouple compression fitting	4304
4301	Air control assembly, 120 volt	n/a
n/a	Air control assembly, 240 volt	4179
4291	20 amp power entry module with switch	4291

ACCESSORIES

<u>Part #</u>	<u>Description</u>
ATS1026	Pressure Regulator and Filter
ATS1022	Basket (standard)
ATS1078	Bath lid with handle
ATS1076	Aluminum oxide (20lbs/9kg)
ATS1080	Parts basket 3"ID x 4.5" depth
ATS1089	Parts basket 2.25"ID x 3.75" depth
ATS3082	Probe support for calibrating temperature sensors

Wiring Diagram

FTBSL6 Wiring Diagram

Note: Intersecting lines do not connect unless indicated

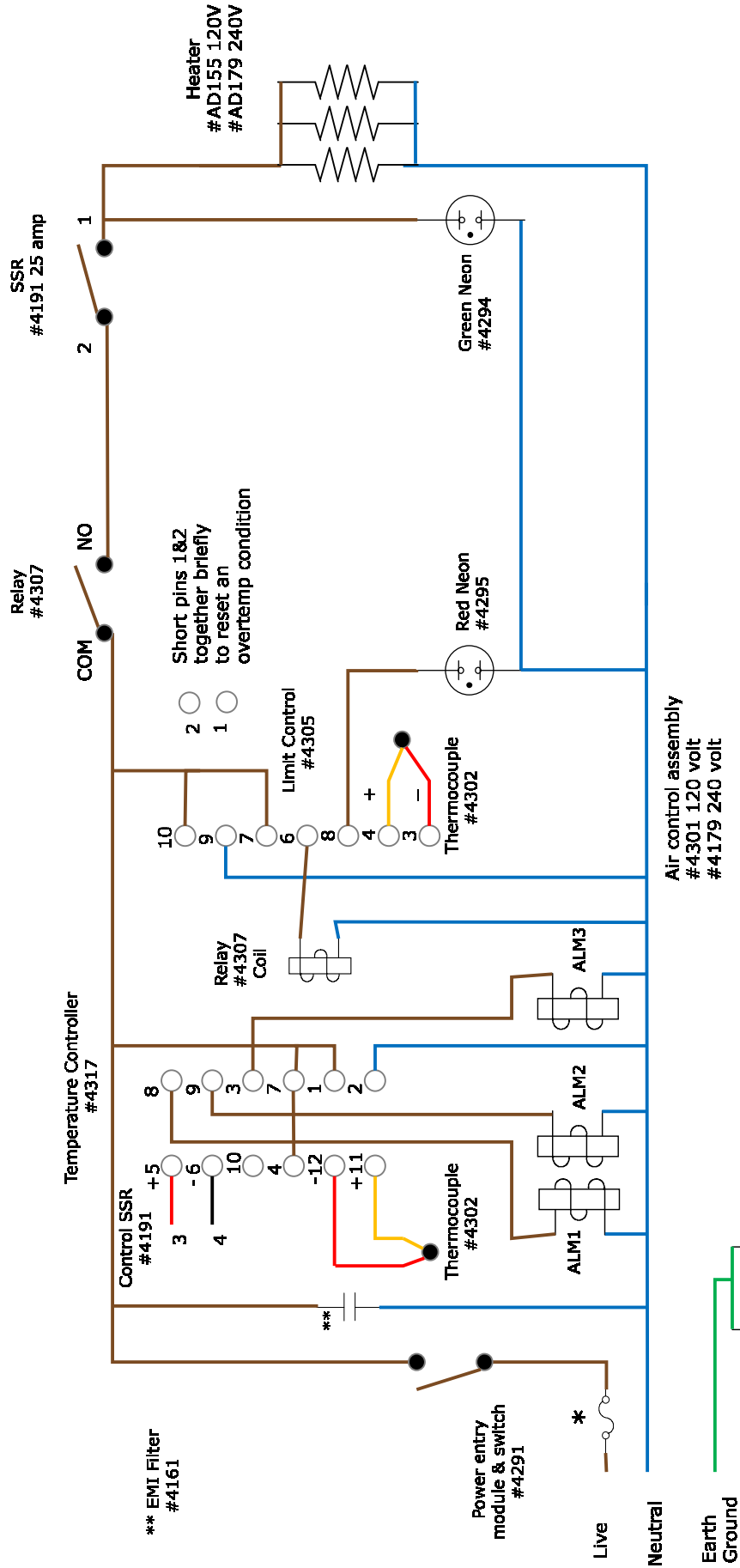

TITLE FTBSL6 WIRING DIAGRAM			
AUTHOR Darren Sager			
DATE 5/17/2016	SHEET 1	OF 1	REVISION 3.0

EC Declaration of Conformity

In accordance with EN ISO 17050-1:2004

We Accurate Thermal Systems
of 4104 Sylon Blvd, Hainsport, NJ 08036, USA

in accordance with the following Directives:

2006/95/EC	The Low Voltage Directive
2004/108/EEC	The Electromagnetic Compatibility Directive
2011/65/EU	The Restriction of Hazardous Substances Directive

hereby declare under our sole responsibility that:

Equipment	Fluidized Temperature Bath
Model numbers	FTBSL12, FTBSL26 & FTBSL6

is in conformity with the applicable requirements of the following documents:

Ref. No.	Title	Edition/date
BS EN 60519-1	Safety in electroheating installations. General requirements	2011
BS EN 61000-6-2	Electromagnetic compatibility (EMC). Generic standards. Immunity for industrial environments	2005
BS EN 61000-6-4	Electromagnetic compatibility (EMC). Generic standards. Emission standard for industrial environments	2007 + A1:2011

I hereby declare that the equipment named above has been designed to comply with the relevant sections of the above referenced specifications. The unit complies with all applicable Essential Requirements of the Directives.

Signed by:*DARREN SAGER*.....

Name: Darren Sager
Position: President
Done at Accurate Thermal Systems
On April 1, 2015



Document number.
DC16-FTBLS12 – V2