

- * FULLY ISOLATED
- * THERMO-HEAD
INSTALATION
- * 0.1% ACCURACY
- * FIELD RANGEABLE
VIA DIP SWITCH
(NO SOLDERING)
- * LOW 8.5 VDC DROP



DESCRIPTION

The SM815 isolated two wire mV/TC transmitter receives signals from thermocouples or other millivolt sources and provides a proportional 4 to 20 mA output signal which is completely isolated from the input. Because the SM815 is a two wire device, a single pair of twisted copper wires are all that is required to provide power to the unit as well as to carry the output current.

The SM815 is field calibratable, accepting inputs from type J, K, E, R, S & T thermocouples, with millivolt spans ranging from 4 to 64 millivolts. Thermocouple types and ranges are selected using a 6 position DIP switch and final calibration is accomplished by means of multiturn zero and span potentiometers. The zero pot provides an offset adjustment of $\pm 25\%$ of the span. The SM815 is provided with upscale thermocouple break indication. Four voltage input models are also available, accepting inputs ranging from 4 to 64 mV to 4 to 64 volts.

General Specifications

Power Requirements	8.5 to 35 VDC At Term. Block
Accuracy	0.1 % Of Millivolt Span
Working Temperature	- 25 °C To 85 °C
Storage Temperature	- 65 °C To 125 °C
Thermal Zero Shift	0.01 % /°C (span > 10 mV) 0.02 % /°C (span < 10 mV)
Isolation	500 VRMS
Common Mode Rejection	115 dB at 60 Hz
3 dB Frequency	3 Hz
Weight	2.5 oz.

Input Specifications

Sensor	Thermocouples J, K, T, E, R & S
Voltage Inputs	Option - MV : 4 to 64 mV Option - V1 : 0.04 to 0.64 VDC Option - V2 : 0.4 to 6.4 VDC Option - V3 : 4 to 64 VDC
Input Break Indication	Upscale
Input Offset Adjustment	$\pm 25\%$ of mV Span
Input Source Current	4 nA Typical
Input Resistance	> $3 \times 10^7 \Omega$ (TC & mV Inputs) 226 K (Options V1, V2 & V3)

Output Specifications

Output Range	4 to 20 Milliamps
Output Limits	3 to 28 mA, Typical
Max. Load Resistance	= (supply voltage - 8.5V) / 20 mA
Load Effect	<.01% of Span / 300 Ω Change
Power Supply Effect	<.002% of Span per Volt

Optional Hardware

Enclosures

Aluminum Mounting Head	Option - CHA
Nylon Mounting Head	Option - CHN
Explosion Proof Head	Option - CHX

Mounting Hardware

3 Inch Snap Track Mount	Option - M31S
DIN Rail Mount	Option - M31D

MILLIVOLT SPAN									
		4 to 8	8 to 16	12 to 24	16 to 32	20 to 40	24 to 48	28 to 56	2 to 64
SWITCH 4		ON	OFF	ON	OFF	ON	OFF	ON	OFF
SWITCH 5		ON	ON	OFF	OFF	ON	ON	OFF	OFF
SWITCH 6		ON	ON	ON	ON	OFF	OFF	OFF	OFF
TEMPERATURE SPAN									
TYPE J	°C	80 -150	150-290	220-420	290-600	370-710	420-760		
	°F	140 -270	270-530	400-790	530-1050	560-1320	790-1390		
TYPE K	°C	100-200	200-390	290-580	390-770	480-970	580-1180	670-1370	
	°F	175-355	355-705	530-1045	705-1385	875-1740	1045-2115	1210-2500	
TYPE T	°C	95-175	175-320	250-400					
	°F	175-320	320-585	460-750					
TYPE E	°C	65-125	125-235	180-325	235-440	285-535	325-635	385-735	435-835
	°F	120-230	230-430	335-615	430-795	525-975	615-1155	705-1330	795-1515
TYPE R	°C	450-800	800-1400	1115-1700					
	°F	840-1470	1470-2540	2025-3100					
TYPE S	°C	480-860	860-1535	1200-1760					
	°F	875-1565	1565-2785	2190-3210					

Switch settings for millivolt and temperature spans (see notes)

SM815 - MV	4-8 mV	8-16mV	12-24mV	16-32mV	20-40mV	24-48mV	28-56mV	32-64mV
SM815 - V1	.04-.08 V	.08-.16V	.12-.24V	.16-.32V	.20-.40V	.24-.48V	.28-.56V	.32-.64V
SM815 - V2	0.4-0.8 V	0.8-1.6V	1.2-2.4V	1.6-3.2V	2-4V	2.4-4.8V	2.8-5.6V	3.2-6.4V
SM815 - V3	4-8 V	8-16V	12-24V	16-32V	20-40V	24-48V	28-56V	32-64V

Input spans for voltage input models

	TYPE J	TYPE K	TYPE T	TYPE E	TYPE R	TYPE S
SWITCH 1	ON	OFF	OFF	OFF	OFF	OFF
SWITCH 2	OFF	ON	ON	OFF	OFF	OFF
SWITCH 3	OFF	OFF	OFF	OFF	ON	ON

Switch settings for thermocouple type selection

NOTES

- All input ranges start at 0 millivolts (or 0 °C) with an offset adjustment of approximately $\pm 25\%$ of the millivolt span, using the zero potentiometer.
- Table 1 lists maximum and minimum spans for each switch setting. FOR EXAMPLE with switches 4, 5 & 6 in the on position, the input range can be set from 0 to 4 mV up to 0 to 8 mV using the span potentiometer.

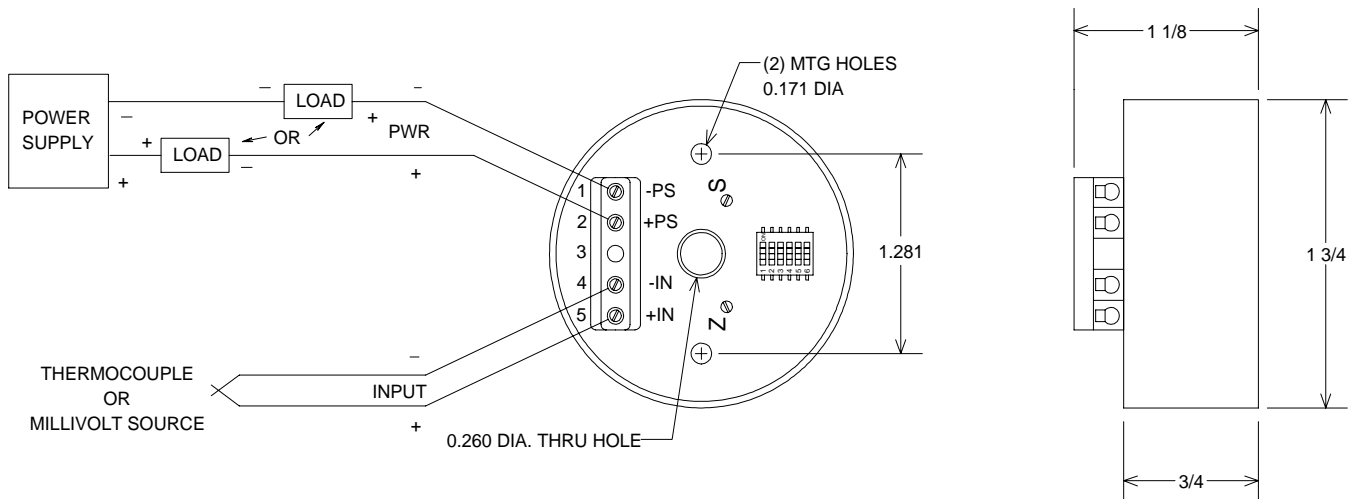

DEVAR Inc.

Distributed By:

IOThrifty

<http://www.IOThrifty.com> email:info@iothrifty.com