

DEVAR Inc.

Distributed by IOthrifty
www.IOThrifty.com
info@IOThrifty.com

Model 18-812

2 Wire
Resistance Transmitter



MANUAL NO. 990602

TABLE OF CONTENTS

PAGE OR DWG. NO.

1 - General Description	1
2 - Specifications	2
3 - Installation	4

LIST OF ILLUSTRATIONS

Typical Wiring (FIG. 3.1)	4
General Dimensions of 18-812 (FIG. 3.2)	5
General Dimensions of M31 Bracket (FIG. 3.3)	5
SnapTrack Mounting Rail (FIG 3.4)	6
Assembly of the 18-812 Transmitter into the SnapTrack Mounting Rail (FIG 3.5)	6
Assembly of the 18-812 Transmitter inside a Connection Head (FIG 3.6)	7
Assembly of the 18-812 Transmitter inside a Junction Box (FIG 3.7)	7

SECTION I

GENERAL DESCRIPTION

- 1.1 The 18-812 two wire resistance transmitter receives signals from single RTD, dual RTD, or a potentiometer and provides an output current of 4 to 20 mA proportional to the input resistance. It is designed to connect with only two copper wire leads that will supply the voltage to operate the transmitter from a power supply, and also carry the output current. The output current is then used for recording, computing, or controlling.
- 1.2 The 18-812 is a miniaturized transmitter designed to fit inside a connection head where the spacing between the mounting holes is 1.281 inches. If the spacing between the mounting holes is other than 1.281 inches, the 18-812 can still be mounted inside the head using an adapter plate. The advantage of putting the transmitter inside a connection head is to eliminate long copper wire leads connected to the RTD element, therefore eliminating lead wire resistance errors.
- 1.3 For RTD inputs, a three segment linearizing circuit can be provided as an option (-L). This circuit linearizes the output current with respect to the sensed temperature of the RTD. The unit has reverse supply polarity protection, and will operate with a wide range of supply voltages (11 to 44 VDC).
- 1.4 The 18-812 is protected from Radio Frequency Interferences (RFI) and Electro Magnetic Interferences (EMI). The unit does not provide isolation between the input and current output. For isolated models refer to DEVAR Model 18-212A-I

SECTION II

SPECIFICATIONS

2.1 General

Size	1.75 inch O.D. by 1.125 inch height Including wiring terminals
Power Requirements	11 to 44 VDC at power terminals
Accuracy	0.1% of span (Includes combined effects of hysteresis, repeatability, and linearity referred to mV input)
Operating Temperature	-25°C to +85°C
Thermal Zero Shift	< 0.01%/°F of span (Span > 10 mV) < 0.02%/°F of span (Span = 5 to 10 mV)
Thermal Span Shift	< 0.01%/°F of span
Weight	1.5 oz.
RFI Resistance	Rated Class 3-C: 0.25% of span per SAMA PMC 33.1-1978 (15 V/meter field strength, 440 to 450 MHz frequency band)

2.2 Input

Sensor	2 or 3 wire RTD, dual RTD, and variable resistor (10K Ohm max.)
Max. Bridge Current	2 mA
Min. RTD Span	5 Ohms

2.3 Output

Current Output	4 to 20 mA
Current Output Limits	3.4 mA to 27 mA
Load Resistance	$R_L (\text{Max}) = (V_{\text{supply}} - 11) / 20$ (K Ohms)
Load Resistance Effect	0.05% of span per 300 Ohm change
Power Supply Effect	0.01% of output span per Volt

2.4

Options

-10	Input Range -40 to 120° F
-11	Input Range 0 to 200°F
-12	Input Range 0 to 300°F
-13	Input Range 0 to 500°F
-14	Input Range 0 to 750°F
-15	Input Range 0 to 1000°F
-M31ST	3" SnapTrack (holds 2 units)
-ST	3" SnapTrack (specify length)
-M31D	DIN Rail Mounting Hardware
-DR	DIN Rail (specify length)
-CHN	Nylon Connection Head
-CHA	Aluminum Connection Head
-CHAS	Aluminum Connection Head, snap top
-CHX	Explosion Proof Connection Head
-RTDSF - (length)	Spring Loaded RTD (specify length)
-RTDBF - (length)	Brazed Loaded RTD (specify length)
-W - (length)	Thermowell (specify length)
-JB	Junction Box
-L	A linearizing circuit can be provided. The output current is proportional to the sensed temperature with a linearity of $\pm 0.1\%$ plus a 4:1 improvement in the RTD curve.

SECTION III

INSTALLATION

3.1 The 18-812 two wire resistance transmitter can be surface mounted, or installed into a SnapTrack mounting rail using a M31 bracket. Because of the small size, 12 units will fit onto each foot length of a 3" wide SnapTrack. In addition, the 18-812 transmitter can be mounted inside a connection head or a junction box. For example, the unit can be mounted directly into the following connection heads:

- 1 - Omega Engineering, type NB1
- 2 - ROSSTEMP, type BKK
- 3 - National Basic Sensor, type 5HN27

3.2 Connect appropriate DC power source in series with load to (+) and (-) power terminals. Note, the load may be connected to either the (+) or (-) power lead. Also connect the RTD element or the variable resistor to the input terminals. Refer to FIG 3.1 for detailed wiring instructions.

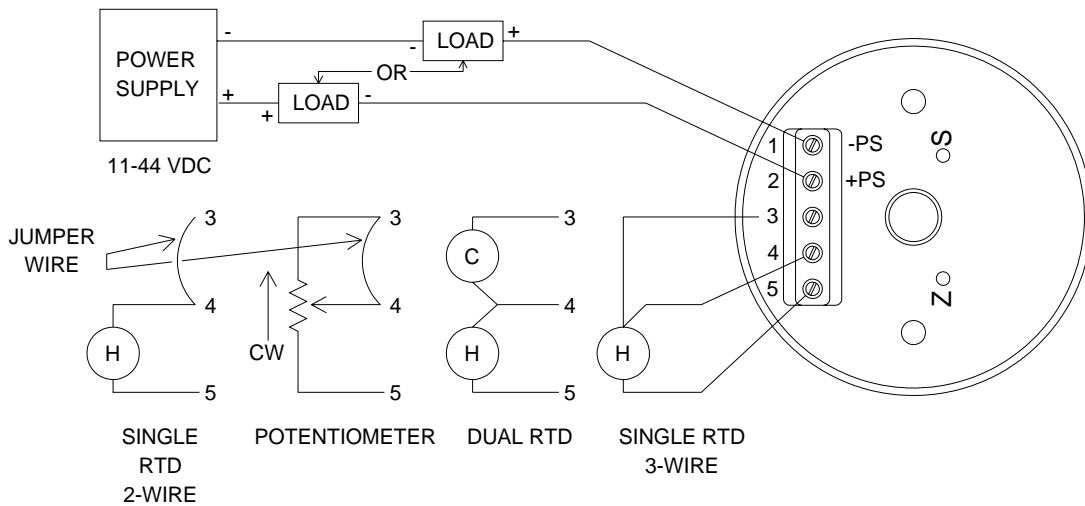

FIG. 3.1 - Typical Wiring

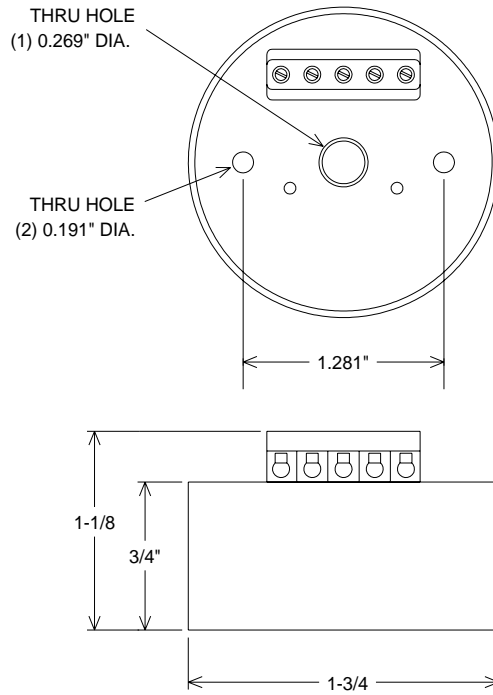

FIG. 3.2 - General Dimensions of 18-812

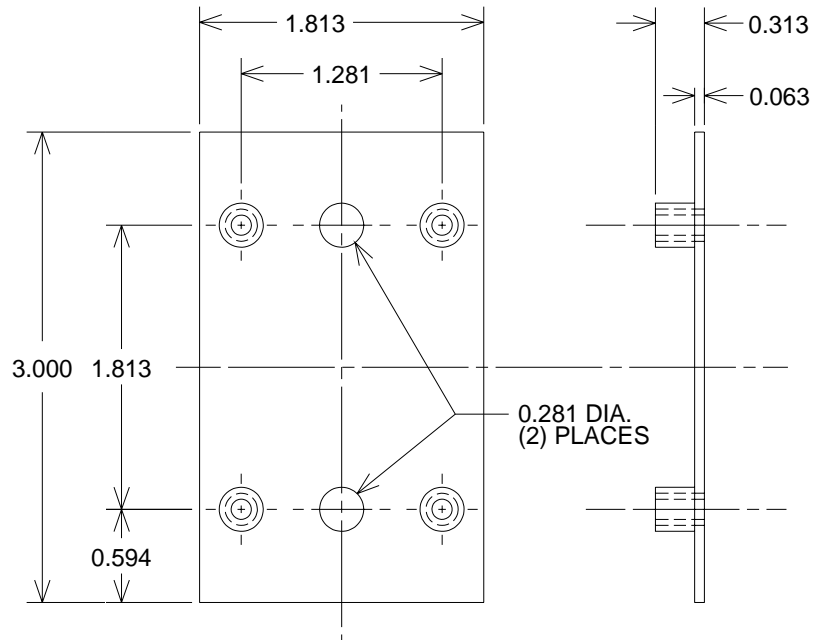

FIG. 3.3 - General Dimensions of M31 Bracket

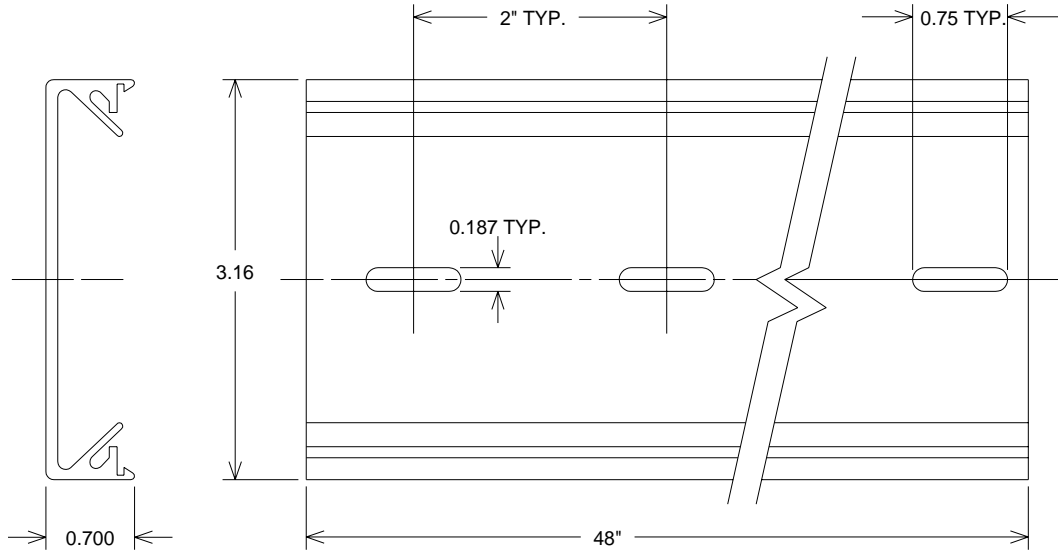

FIG. 3.4 - General Dimensions of SnapTrack Mounting Rail

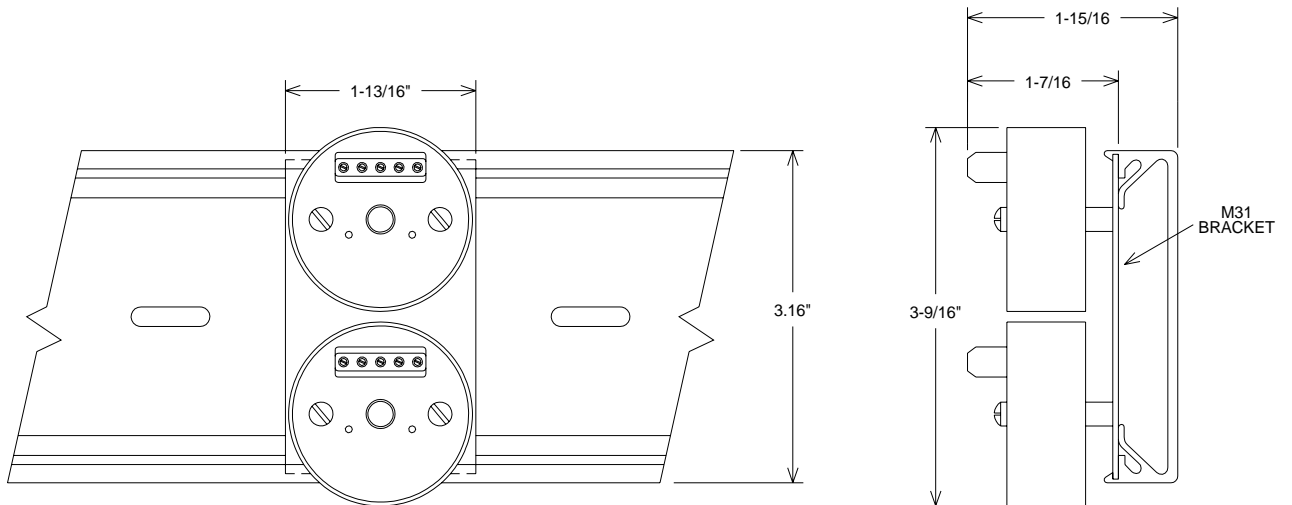

FIG. 3.5 - Assembly of the 18-812 Transmitter into the SnapTrack Mounting Rail

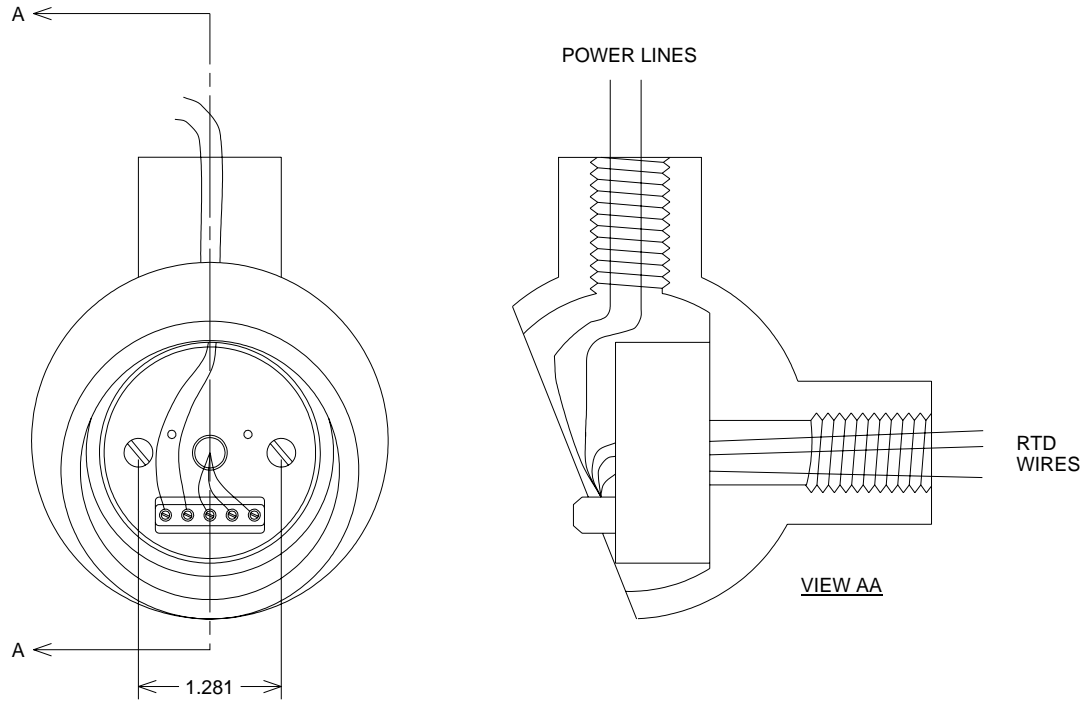

FIG. 3.6 - Assembly of the 18-812 Transmitter inside a connection head

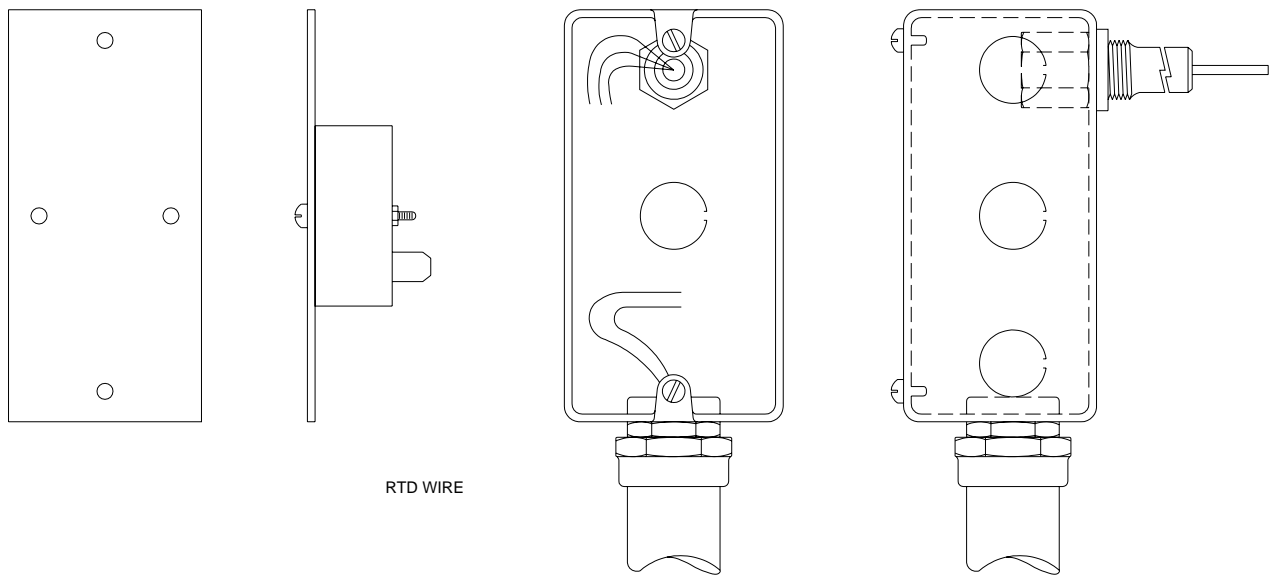

FIG. 3.7 - Assembly of the 18-812 Transmitter inside a junction box