



MARATHON

BEST IN THE LONG RUN

STOPWATCH CATALOGUE
PROFESSIONAL GRADE





TABLE OF CONTENTS

04	ADANAC 3000
05	ADANAC 3000
06	ADANAC 4000
07	ADANAC 5000
08	ADANAC 7000
09	ADANAC 8000
10	ADANAC SOLAR
11	PACKAGING SPECIFICATIONS

*Batteries always included.

ADANAC 3000



ONE LINE DISPLAY

1/100th Second
Seconds
Minutes
Hours

KEY FEATURES

Digital LCD
12 or 24 HR Format
Time, Date and Month
Time Out and Split Feature
Daily Alarm
Water Resistant
Washable Lanyard

NSN	COLOURS	SKU	UPC
6645-01-106-4302	BLACK	ST083000	 0 63442 90002 4
	BLACK - RED	ST083000HT	 0 63442 90010 9
	RED	ST083000RD	 0 63442 90037 6
	YELLOW	ST083000YE	 0 63442 90030 7

DIMENSIONS

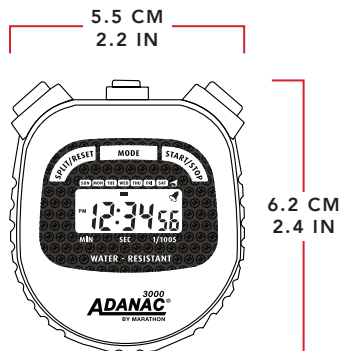

ADANAC 3000

NEON







ONE LINE DISPLAY

1/100th Second
Seconds
Minutes
Hours

KEY FEATURES

Digital LCD
12 or 24 HR Format
Time, Date and Month
Time Out and Split Feature
Daily Alarm
Water Resistant
Washable Lanyard

**SOLD INDIVIDUAL OR
AS A 3-PACK**

NSN	COLOURS	SKU	UPC
	NEON GREEN	ST083000NG	 0 63442 90040 6
	NEON ORANGE	ST083000NO	 0 63442 90041 3
	NEON PINK	ST083000NP	 0 63442 90042 0
	NEON 3-PACK	ST083000NEONSET	 0 63442 90043 7

DIMENSIONS

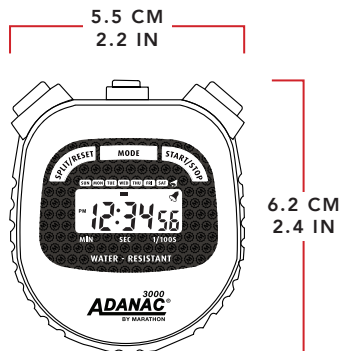

ADANAC 4000





ONE LINE DISPLAY

1/100th Second
Seconds
Minutes
Hours

KEY FEATURES

Large Grip Casing
Big Buttons
Digital LCD
12 or 24 HR Format
Time, Date and Month
Time Out and Split Feature
Daily Alarm
Water Resistant
Washable Lanyard

NSN	COLOURS	SKU	UPC
6645-01-106-4303	BLACK	ST083009	 0 63442 90003 1
	RED	ST083009RD	 0 63442 90038 3
	YELLOW	ST083009YE	 0 63442 90030 7
	NEON ORANGE	ST083009NO	TBA

DIMENSIONS

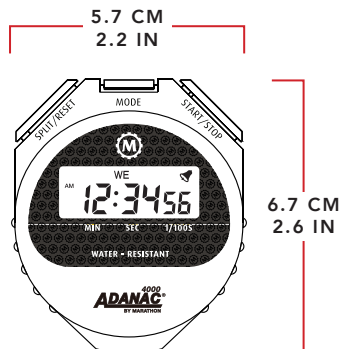

ADANAC 5000

WITH BACKLIGHT





TWO LINE DISPLAY

1/100th Second
Seconds
Minutes
Hours

KEY FEATURES

Jumbo Digits
Digital LCD
12 or 24 HR Format
Time, Date and Month
Time Out and Split Feature
Daily Alarm
EL Backlight
Water Resistant
Washable Lanyard

NSN	COLOURS	SKU	UPC
	BLACK	ST083013	 0 63442 90019 2
	RED	ST083013RD	 0 63442 90035 2
	YELLOW	ST083013YE	 0 63442 90028 4

DIMENSIONS

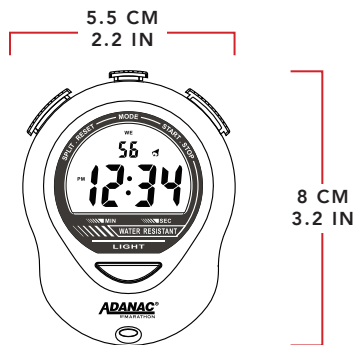

ADANAC 7000

WITH BACKLIGHT



TOP VIEW

ONE LINE DISPLAY

- 1/100th Second
- Seconds
- Minutes
- Hours

KEY FEATURES

- Non-slip Comfort Grip
- Soft Rubber Case
- Digital LCD
- 12 or 24 HR Format
- Time, Date and Month
- Time Out and Split Feature
- Daily Alarm
- Water Resistant
- Lanyard with Safety Release
- Hourly Chime On/Off Function
- EL Backlight Display
- Easy Access Battery Hatch

NSN

COLOURS

SKU

UPC

BLACK

ST083022



DIMENSIONS

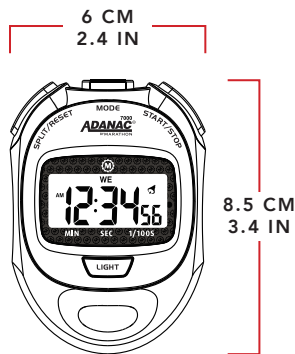

ADANAC 8000

WITH BACKLIGHT



TOP VIEW

ONE LINE DISPLAY

- 1/100th Second
- Seconds
- Minutes
- Hours

KEY FEATURES

- NEW** Tactile Buttons
- Digital LCD
- 12 or 24 HR Format
- Time, Date and Month
- Time Out and Split Feature
- Daily Alarm with Snooze
- Hourly Chime On/Off Function
- EL Backlight Display
- Water Resistant
- Lanyard with Safety Release
- Easy Access Battery Hatch

NSN

COLOURS

SKU

UPC

BLACK

ST083021



DIMENSIONS





TWO LINE DISPLAY

1/100th Second
Seconds
Minutes
Hours

KEY FEATURES

99 Split/Lap Time Counters
9 Split/Lap Time Memories
Key Tone On/Off Function
Dual Power (Solar and Battery)
Water Resistant
Ergonomic Case Design
Washable Lanyard

NSN

COLOURS

SKU

UPC

BLACK - ORANGE

ST083020



DIMENSIONS

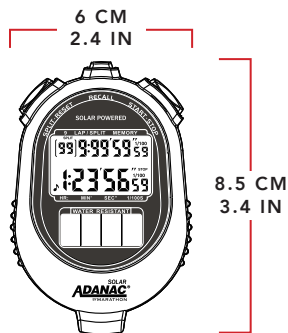

PACKAGING SPECIFICATIONS

INDIVIDUAL BOX

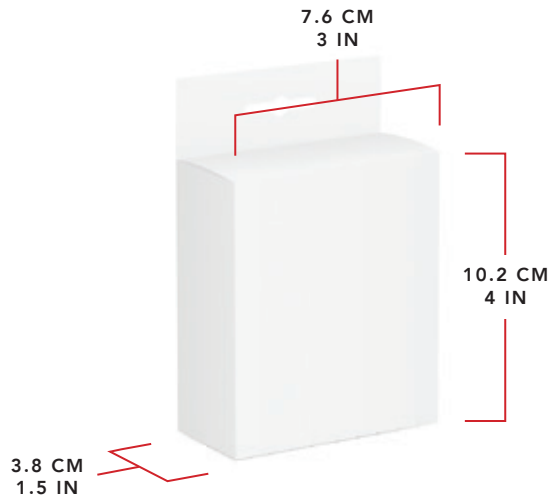

INDIVIDUAL BOX SIZE
CONTAINS 1 UNIT

INNER BOX SIZE
CONTAINS 10 UNITS

MASTER BOX SIZE
CONTAINS 100 UNITS

7.6 X 10.2 X 3.8 CM
3 X 4 X 1.5 IN

17.8 X 21.6 X 8.9 CM
7 X 8.5 X 3.5 IN

22.9 X 35.6 X 2.5 CM
9 X 14 X 19 IN

3-PACK BOX

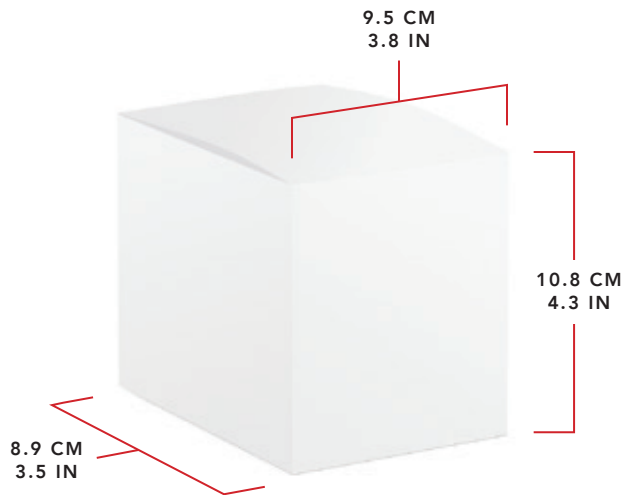

3-PACK BOX SIZE
CONTAINS 3 UNITS

INNER BOX SIZE
CONTAINS 4 PACKS

MASTER BOX SIZE
CONTAINS 32 PACKS

9.5 X 10.8 X 8.9 CM
3.8 X 4.3 X 3.5 IN

19.1 X 12.1 X 17.8 CM
7.5 X 4.8 X 7 IN

40.6 X 27.9 X 38.1 CM
16 X 11 X 15 IN

DON'T MISS OUT ON OUR
OTHER CATALOGUES:

Watch Catalogue
Clock Catalogue
Timer Catalogue
Mechanical Stopwatches Catalogue
Lasers Catalogue

FOR MORE INFORMATION
PLEASE CONTACT US:

North America: +1-800-822-4329
International: +1-905-764-9420
Fax: +1-905-764-0035
Email: sales@marathonwatch.com
www.MarathonWatch.com