



**LED CLOCK
WITH USB CHARGING STATION
MODEL CL030055 SERIES**



Please read this instruction manual before using your new clock.

SECTION 1

MAIN FEATURES

The following buttons (except and **RESET** buttons) are functional only when the clock is powered with the DC adaptor.

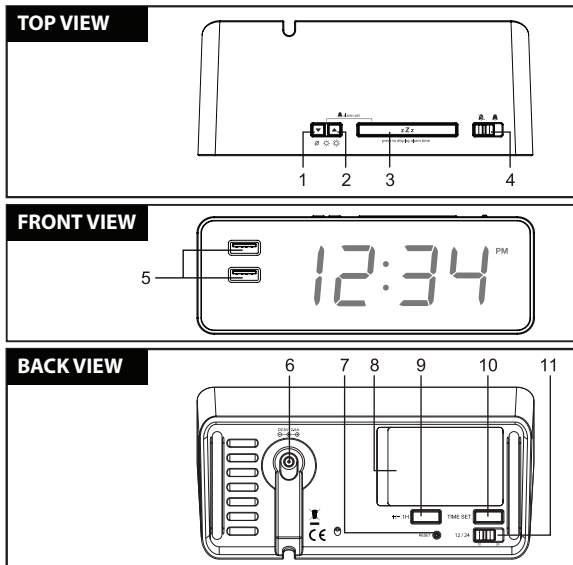

1. **▼ button**
 - Press this button to turn off the LED display or decrease the display's brightness.
 - In time setting mode and alarm time setting mode, press this button to decrease the value. Press and hold to decrease the value rapidly.
2. **▲ button**
 - Press this button to turn on the LED display or increase the display's brightness.
 - In time setting mode and alarm time setting mode, press this button to increase the value. Press and hold to increase the value rapidly.
3. **button**
 - Press this button to view the alarm time.
 - Press and hold this button, then press ▲ or ▼ to set the alarm time.
 - When the alarm sounds, press this button to turn off the current alarm and turn on the snooze function.
4. **slide switch**
 - Slide this switch to turn off or on the alarm function.
5. **2 USB ports**
6. **DC jack**
 - Connect the DC adaptor to power the clock.
7. **RESET button**
 - In case of a malfunction, press this button with a metal pin to reset all values.
8. **Battery compartment**
 - Accommodates 3 AAA batteries as a backup power source.
9. **button**
 - This button adds or subtracts one hour from the current time.

10. button

- In normal time mode, press and hold this button to enter time setting mode. Release the button to save the time and exit time setting mode.

11. 12 / 24 slide switch

- Slide this switch to the "12" position to display the time in 12-hour format.
- Slide this switch to the "24" position to display the time in 24-hour format.

SECTION 2

POWERING ON

1. The clock must be powered by the DC adaptor. The 3 AAA batteries are used only as a backup power source for the time and alarm settings.
2. After powering on or resetting the clock, all LED segments will be shown for 2 seconds. Then the clock will revert back to normal time mode and display the time.

NOTE:

If nothing is visible on the LED display, please make sure the clock is connected to an electrical outlet using the DC adaptor. Then, press the **RESET** button with a metal pin.

SECTION 3

DISPLAY SYMBOLS

NORMAL TIME MODE

1. Normal time



ALARM TIME MODE

1. Alarm time
2. Alarm mode icon / Alarm on



SECTION 4

TIME SETTING

1. In normal time mode, press and hold the button until the digits flash. While holding the button, press the ▲ button or the ▼ button to set the desired value.
2. Release the button to save the time and exit time setting mode.

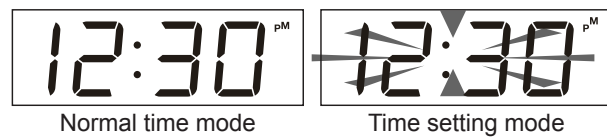

NOTE:

Press and hold the ▲ button to increase the value rapidly. Press and hold the ▼ button to decrease the value rapidly.

SECTION 5

DAYLIGHT SAVING TIME

1. Press the button to activate the daylight saving time function. One hour will be added to the current time.
2. Press the button again to deactivate this function. One hour will be subtracted from the current time.

SECTION 6

SETTING THE ALARM

1. In normal time mode, press and hold the **[ZZZ]** button until the "AL" icon flashes. While holding the **[ZZZ]** button, press the **▲** button or the **▼** button to set the desired value.
2. Release the **[ZZZ]** button to save the alarm time and exit the alarm time setting mode.

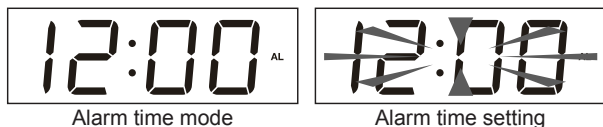

Alarm time mode

Alarm time setting

NOTE:

Press and hold the **▲** button to increase the value rapidly.
Press and hold the **▼** button to decrease the value rapidly.

SECTION 7

ALARM AND SNOOZE FUNCTIONS

Slide the **[ON/OFF]** switch to the "ON" position to turn on the alarm function. The alarm icon "AL" will be displayed. When the alarm is set to "ON", the alarm will sound at the set time. The alarm will stop automatically after one minute if no buttons are pressed. It will sound again at the same time the following day.

To stop the alarm:

1. Press the **[ZZZ]** button to stop the alarm and enter the snooze mode. The alarm icon "AL" will flash continuously. The alarm will sound again after 5 minutes. The snooze function can be used continuously for 24 hours.
2. Slide the **[ON/OFF]** switch to the "OFF" position to turn off the alarm function.

SECTION 8

LED BRIGHTNESS

This LED clock has 3 levels of brightness: OFF, LOW, and HIGH.

- In normal time mode, press the **▲** button to increase the level of brightness.
- In normal time mode, press the **▼** button to decrease the level of brightness.

NOTE:

The LED display will automatically turn on 5 minutes before the set alarm time even if the user turns off the display.

SECTION 9

USB CHARGING PORTS

The USB charging ports located at the front of the clock are compatible with various devices, including mobile phones, tablets, and notebooks.

1. When **both** USB ports are used, low voltage devices (5 V, 1 A) can be charged.
2. When **one** USB port is used, a higher voltage device (5 V, 2.1 A) can be charged.

NOTE:

The clock must be connected to a power source using the DC adaptor in order to use the USB charging ports.

SECTION 10

IMPORTANT

- This clock is intended for indoor use only.
- Do not subject the clock to excessive force or shock.
- Do not expose the clock to extreme temperatures, direct sunlight, dust, or moisture.
- Do not immerse the clock in water.
- Avoid contact with corrosive materials.
- Do not dispose of the clock in a fire, as it may explode.
- The clock should be placed near an easily accessible electrical outlet.
- Do not open the inner back case of this clock or tamper with any of its components.
- Please dispose of this clock and any used batteries in an ecologically safe manner.

SECTION 11

FCC DISCLAIMER

This device complies with part 15 of the FCC rules. Operation is subject to the following two conditions: (1) this device may not cause harmful interference, and (2) this device must accept any interference received, including interference that may cause undesired operation.

Modifications not expressly approved by this company could void the user's authority to operate the equipment.

This equipment has been tested and found to comply with the limits for a Class B digital device, pursuant to Part 15 of the FCC Rules. These limits are designed to provide reasonable protection against harmful interference in a residential installation. This equipment generates, uses, and can radiate radio frequency energy and, if not installed and used in accordance with the instructions, may cause harmful interference to radio communications.

However, there is no guarantee that interference will not occur in a particular installation. If this equipment does cause harmful interference to radio or television reception, which can be determined by turning the equipment off and on, the user is encouraged to try to correct the interference using one or more of the following measures:

- Re-orient or relocate the receiving antenna.
- Increase the separation between the equipment and the receiver;
- Connect the equipment to an outlet on a circuit different from that to which the receiver is connected.
- Consult the dealer or an experienced radio/TV technician for help.

SECTION 12

SPECIFICATIONS

Main power:	5 V / 2.5 A DC Adaptor
Backup power:	3 AAA batteries (Batteries used alone will not power the USB charging ports.)
Operating temperature range:	-5 °C to 50 °C (23 °F to 122 °F)

SECTION 13

WARRANTY

Marathon Watch Company warrants this item to be free from defects in material and workmanship under normal use in accordance with care and usage instructions for 2 years from date of purchase from an authorized retailer. This warranty excludes damage from misuse, abuse or any irregular application. Return the item to us properly packaged accompanied with the original bill of sale. Please contact Customer Service at 1-800-822-4329 to obtain the shipping address. If we confirm a defect, we will replace it with the same item or one of similar value and return it to you at no charge.

Marathon Watch Company Ltd.
www.MarathonWatch.com
Customer Service: 1-800-822-4329



Marathon Watch Company Ltd.
www.MarathonWatch.com

Designed in Canada / Conçu au Canada
Made in China / Fabriqué en Chine

2 YEAR warranty
Garantie de 2 ANS