



Polyga C506 3D SCANNER

Ruggedized **X** Macro

Easy to Use, High Accuracy 3D Scanning

Convenient and easy to use, this professional 3D scanner is factory calibrated for accuracy to get you 3D scanning in no time. The Polyga Compact 3D scanners are great for any companies, manufacturers, academic institutions, visual effect studios, and research labs that need accurate and reliable 3D scan data for visualization and measurement applications including:

- Reverse engineering
- Computer and robotic vision
- Scientific measurement and documentation
- Quality inspection
- 3D modeling
- Rapid prototyping / 3D printing

The C506 3D Scanner is IP76 rated, dust proof and vibration resistant. It's ideal for inspecting and 3D scanning small objects. It has an incredible accuracy of 12 micron across a 5 cm FOV.

C506 for parts:
3 cm to 10 cm in size

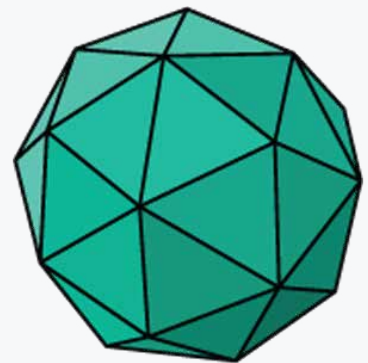

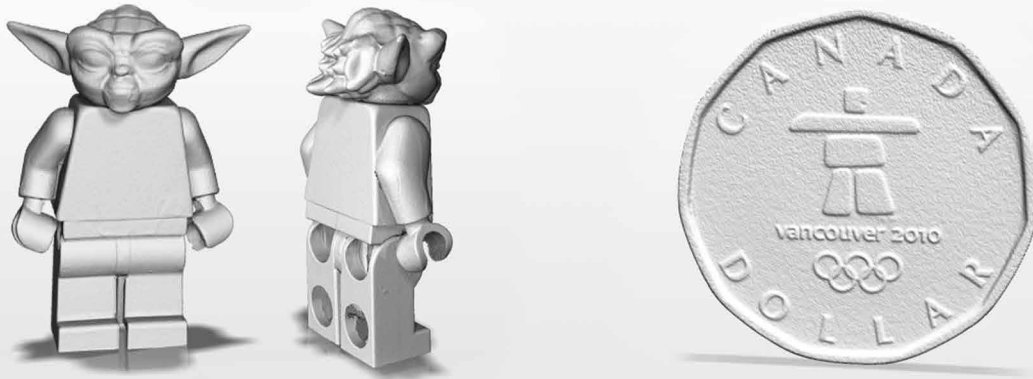

Specifications

Cameras: 2 x 5 megapixel mono

Accuracy: 12 microns

Average Points: 5 Million

Scan Speed: 333 ms

Size: 170mm x 136mm x 49mm

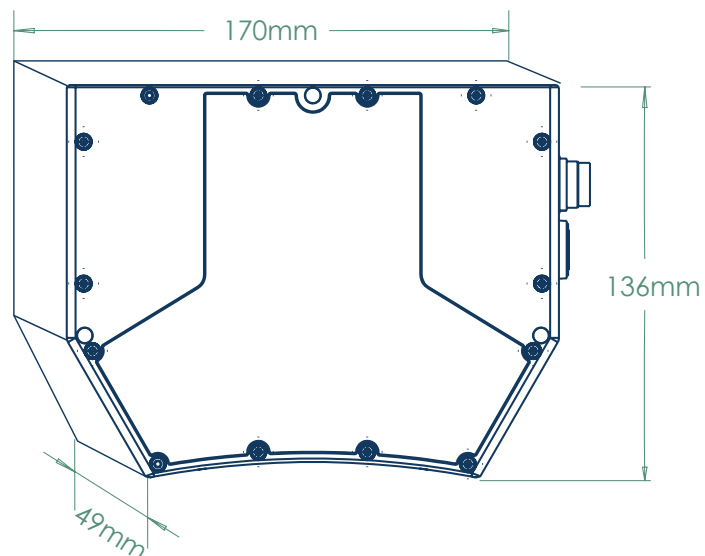

Specifications

Field of View & Standoff Distance

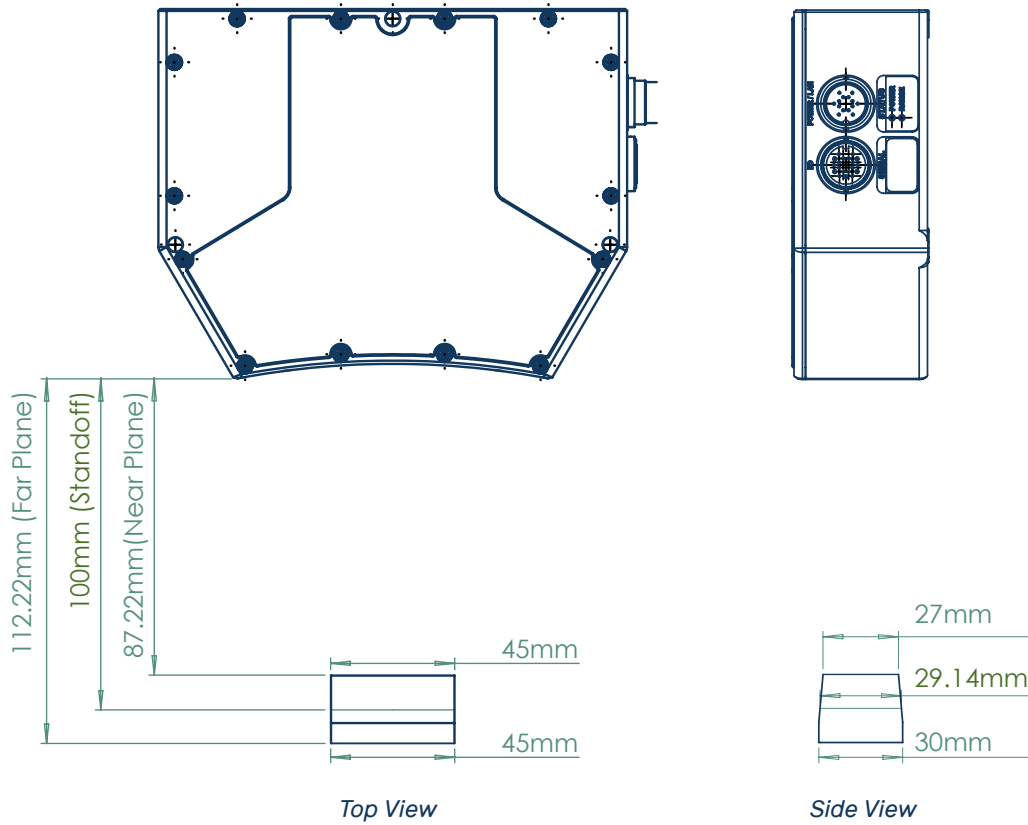

Field of View: 45 x 27 – 45 x 30 mm (55 mm)

Standoff: 100 mm

Point to Point Distance: 0.02 mm

Export Fromats: PLY, STL, OBJ, ASC

Scanning Software: FlexScan3D
