

Vehicle: Electrical Diagrams Late

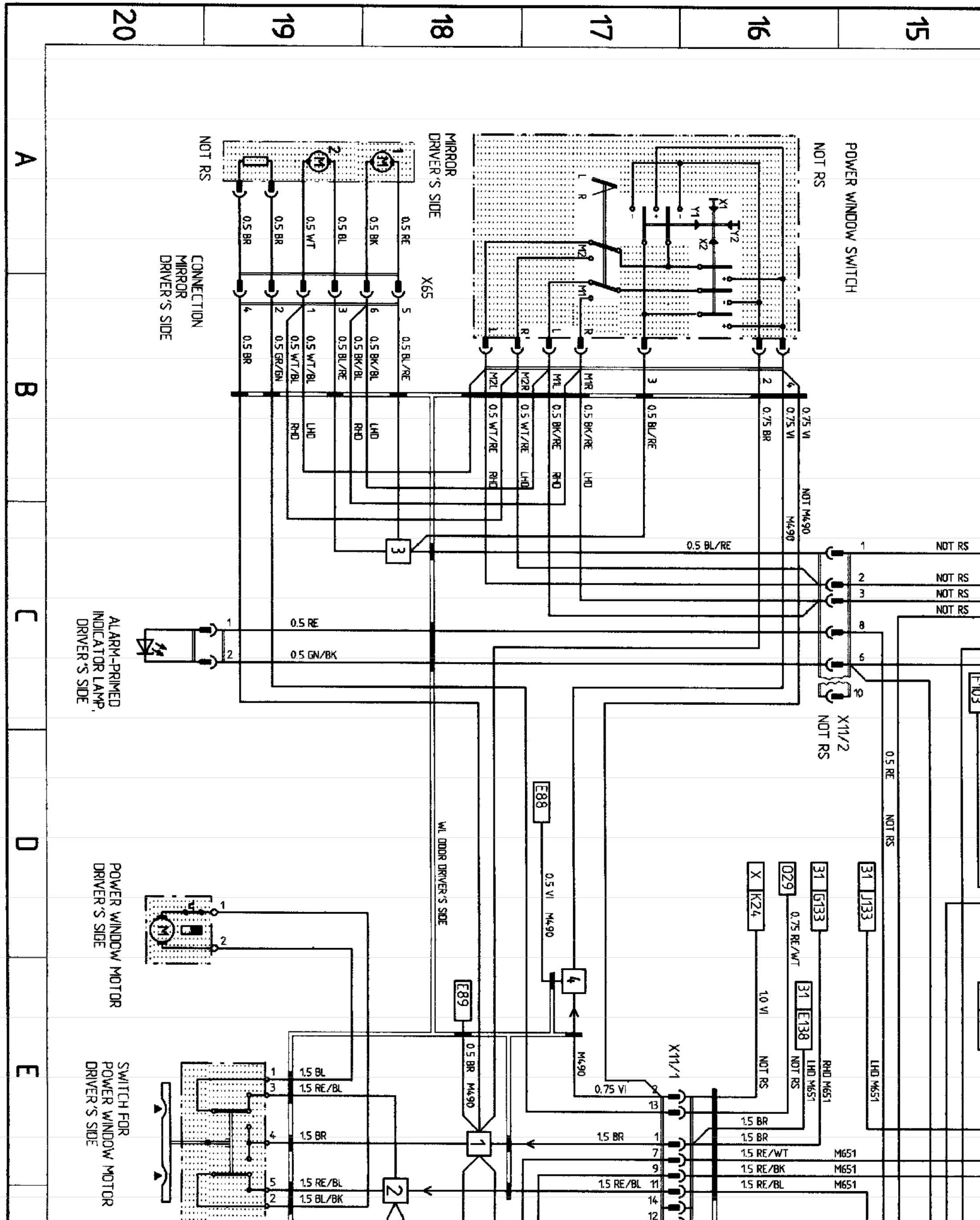

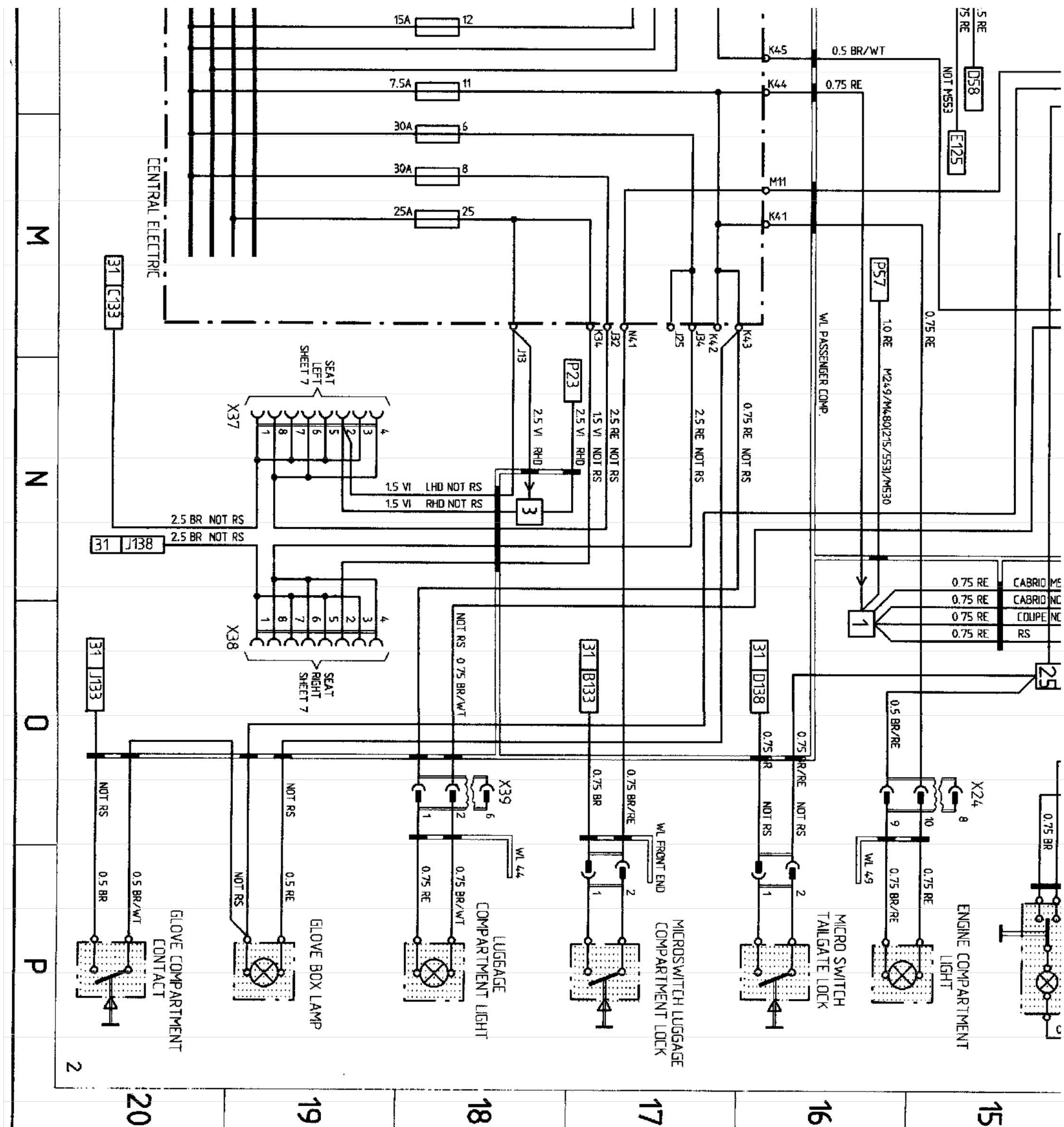

M

N

O

P

2

20

19

18

17

16

15

CENTRAL ELECTRIC

SEAT LEFT SHEET 7

SEAT RIGHT SHEET 7

GLOVE COMPARTMENT CONTACT

GLOVE BOX LAMP

LUGGAGE COMPARTMENT LIGHT

MICROSWITCH LUGGAGE COMPARTMENT LOCK

MICRO SWITCH TAILGATE LOCK

ENGINE COMPARTMENT LIGHT

CABRIO ME

CABRIO NC

COUPE NC

RS

WL PASSENGER COMP.

WL FRONT END

WL 44

WL 49

31 C133

31 J138

31 J133

31 B133

31 D138

X37

X38

X39

X24

SEAT LEFT SHEET 7

SEAT RIGHT SHEET 7

1.5 VI LHD NOT RS

1.5 VI RHD NOT RS

2.5 VI RHD

15 VI NOT RS

2.5 RE NOT RS

2.5 VI NOT RS

2.5 RE NOT RS

2.5 BR NOT RS

2.5 BR NOT RS

NOT RS 0.75 BR/WT

NOT RS

0.5 RE

NOT RS

0.5 BR

0.5 BR/WT

0.75 RE

0.75 BR/WT

0.75 BR

0.75 BR/RE

0.75 BR/RE

0.75 BR

0.75 BR/WT

0.75 RE

0.75 RE

0.75 RE

0.75 RE

0.75 RE

0.75 RE

0.75 RE

0.75 RE

0.75 RE

0.75 RE

0.75 RE

0.75 RE

0.75 RE

0.75 RE

0.75 RE

0.75 RE

0.75 RE

0.75 RE

0.75 RE

0.75 RE

0.75 RE

0.75 RE

0.75 RE

0.75 RE

0.75 RE

0.75 RE

0.75 RE

0.75 RE

0.75 RE

0.75 RE

0.75 RE

0.75 RE

0.75 RE

0.75 RE

0.75 RE

0.75 RE

0.75 RE

0.75 RE

0.75 RE

0.75 RE

0.75 RE

0.75 RE

0.75 RE

0.75 RE

0.75 RE

0.75 RE

0.75 RE

0.75 RE

0.75 RE

0.75 RE

0.75 RE

0.75 RE

0.75 RE

0.75 RE

0.75 RE

0.75 RE

0.75 RE

0.75 RE

0.75 RE

0.75 RE

0.75 RE

0.75 RE

0.75 RE

0.75 RE

0.75 RE

0.75 RE

0.75 RE

0.75 RE

0.75 RE

0.75 RE

0.75 RE

0.75 RE

0.75 RE

0.75 RE

0.75 RE

0.75 RE

0.75 RE

0.75 RE

0.75 RE

0.75 RE

0.75 RE

0.75 RE

0.75 RE

0.75 RE

0.75 RE

0.75 RE

0.75 RE

0.75 RE

0.75 RE

0.75 RE

0.75 RE

0.75 RE

0.75 RE

0.75 RE

0.75 RE

0.75 RE

0.75 RE

0.75 RE

0.75 RE

0.75 RE

0.75 RE

0.75 RE

0.75 RE

0.75 RE

0.75 RE

0.75 RE

0.75 RE

0.75 RE

0.75 RE

0.75 RE

0.75 RE

0.75 RE

0.75 RE

0.75 RE

0.75 RE

0.75 RE

0.75 RE

0.75 RE

0.75 RE

0.75 RE

0.75 RE

0.75 RE

0.75 RE

0.75 RE

0.75 RE

0.75 RE

0.75 RE

0.75 RE

0.75 RE

0.75 RE

0.75 RE

0.75 RE

0.75 RE

0.75 RE

0.75 RE

0.75 RE

0.75 RE

0.75 RE

0.75 RE

0.75 RE

0.75 RE

0.75 RE

0.75 RE

0.75 RE

0.75 RE

0.75 RE

0.75 RE

0.75 RE

0.75 RE

0.75 RE

0.75 RE

0.75 RE

0.75 RE

0.75 RE

0.75 RE

0.75 RE

0.75 RE

0.75 RE

0.75 RE

0.75 RE

0.75 RE

0.75 RE

0.75 RE

0.75 RE

0.75 RE

0.75 RE

0.75 RE

0.75 RE

0.75 RE

0.75 RE

0.75 RE

0.75 RE

0.75 RE

0.75 RE

0.75 RE

0.75 RE

0.75 RE

0.75 RE

0.75 RE

0.75 RE

0.75 RE

0.75 RE

0.75 RE

0.75 RE

0.75 RE

0.75 RE

0.75 RE

0.75 RE

0.75 RE

0.75 RE

0.75 RE

0.75 RE

0.75 RE

0.75 RE

0.75 RE

0.75 RE

0.75 RE

0.75 RE

0.75 RE

0.75 RE

0.75 RE

0.75 RE

0.75 RE

0.75 RE

0.75 RE

