

# **Kr**äus®

INSTALLATION MANUAL

## **Oletto™ Single Handle Pull Down Kitchen Faucet**

**KPF-2633**

## **Congratulations on the purchase of your new Kraus® plumbing fixture!**

Please keep the box and packaging materials until your product is completely installed. If you have any questions, require technical assistance or have any problems with your product:



**DO NOT RETURN TO STORE**

**Please contact our Customer Service Team  
1-800-775-0703 / [customerservice@kraususa.com](mailto:customerservice@kraususa.com)**

Have the model number available and retain a copy of your receipt with purchase date for reference.

If for any reason this product does not meet your expectations, please be sure to repack this product in the original box and packaging material to avoid damage during transit.

**STOP**

### Prior to Installation:

- Make sure you have all necessary parts by checking the diagram and parts list. If any part is missing or damaged, please contact Kraus<sup>®</sup> Customer Service at 800-775-0703 for a replacement.
- Read all instructions and safety warnings and ensure you have all tools, parts, and equipment necessary for a safe installation.
- Turn off the hot and cold water supply at the angle stops and turn on the old faucet to release any built up pressure. Remove existing faucet.
- Pre-drilled hole size requirement: 1 3/8" (min)
- Max countertop thickness: 2 7/8"

For technical assistance or replacement parts, please contact Kraus Customer Service and one of our representatives will be happy to help:

Toll-Free: 800-775-0703 or [Customerservice@kraususa.com](mailto:Customerservice@kraususa.com)

### Tools Required



### Care & Maintenance

- \* To keep the product clean & shining, follow the steps below:
  1. Rinse with clean water & dry with a soft cloth
  2. Do not clean with soaps, acid, polish, abrasives or harsh cleaners
  3. Do not use cloth with a coarse surface
  4. Unscrew the aerator and clean when necessary
- \* This installation manual is subject to change without further notice.



## Diagram and Parts List

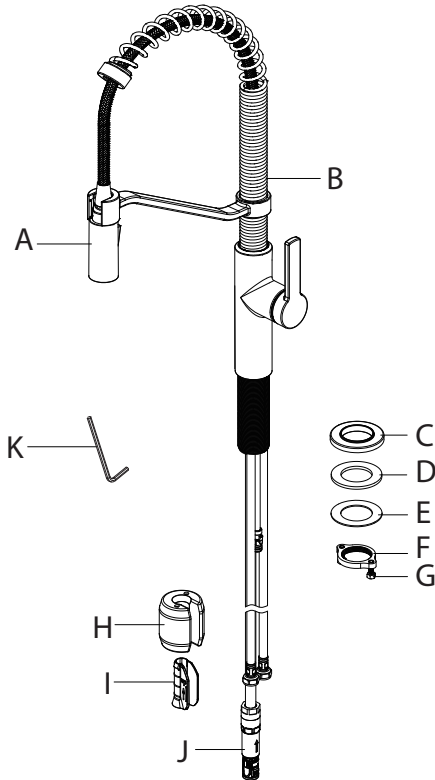

A. Spray Head

B. Faucet Body

C. Flange

D. Rubber Washer

E. Metal Washer

F. Mounting Nut

G. Screws

H. Weight

I. Weight Clip

J. Quick Connector

K. Hex Wrench

# Faucet Dimensions

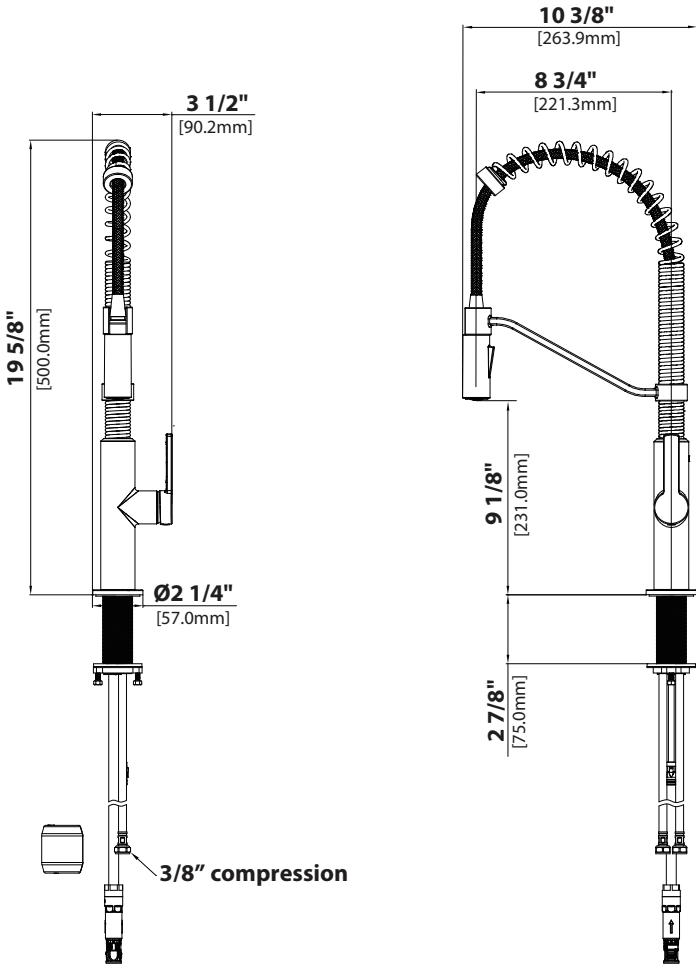

## Installer Tip:

Shut off main water supply before installing new faucet.

## Step 1: Installing the faucet

---

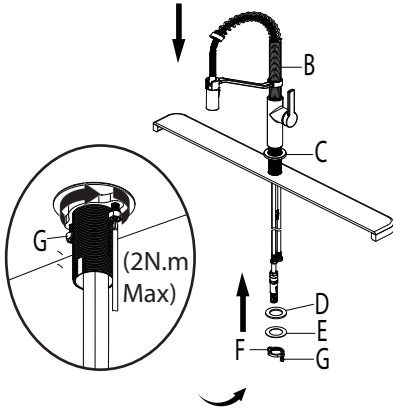

Shut off the water supply. Ensure that the flange (C) is placed on the bottom of the new faucet assembly. Place the faucet (B) through the hole in the countertop. Secure the faucet (B) to the countertop using the rubber washer (D), metal washer (E) and mounting nut (F) provided. Tighten screws (G). Do not overtighten.

## Step 2: Securing the faucet assembly

---

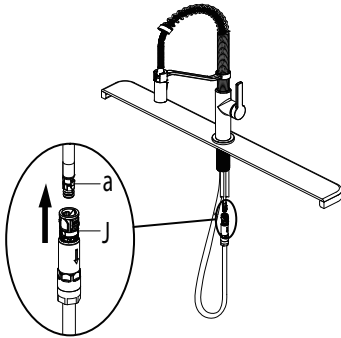

Push the quick connector (I) firmly upward and attach it to the receiving block (a). Pull down moderately to ensure the connection has been made.

## Step 3: Installing the counterweight

---

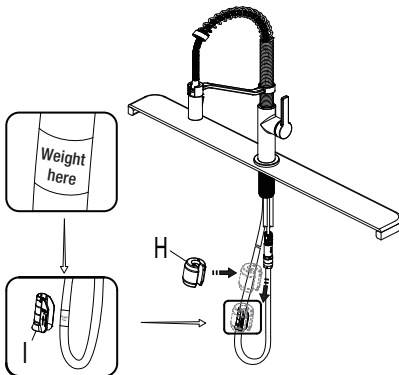

Install the weight clip (I) at the point of the hose marking "weight here". Insert the weight (H) onto the weight clip (I) by sliding it down onto the weight clip (I).

## Step 4: Connect waterlines to main valve

---

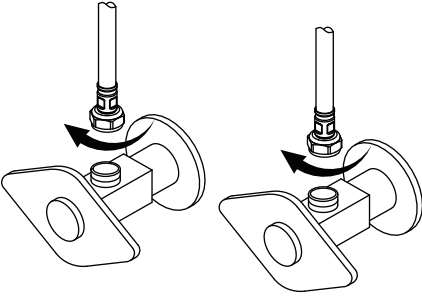

Attach waterlines to angle stops and tighten until snug. Turn on angle stops and check for leaks (**DO NOT TURN FAUCET ON**).

**NOTE:** Please make sure filter washers are installed before connecting to the main valve.

## Step 5: Flush faucet

---

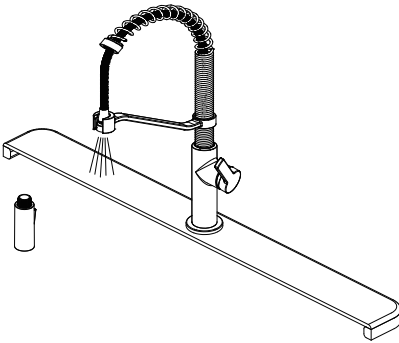

Pull the hose assembly out of the spout and remove the spray head by unscrewing it from the hose in a counterclockwise direction. Be sure to hold the end of the hose down into the sink and turn the faucet on to the warm position where it mixes hot and cold water. Flush the water lines for one minute. This flushes away any debris that could cause damage to internal parts. Check for leaks. Retighten any connections if necessary, but do not overtighten. Reinstall the spray head by hand tightening it back onto the spray hose. After installation is completed, turn on the hot and cold water supplies. Check for leaks.

# Replacement Parts

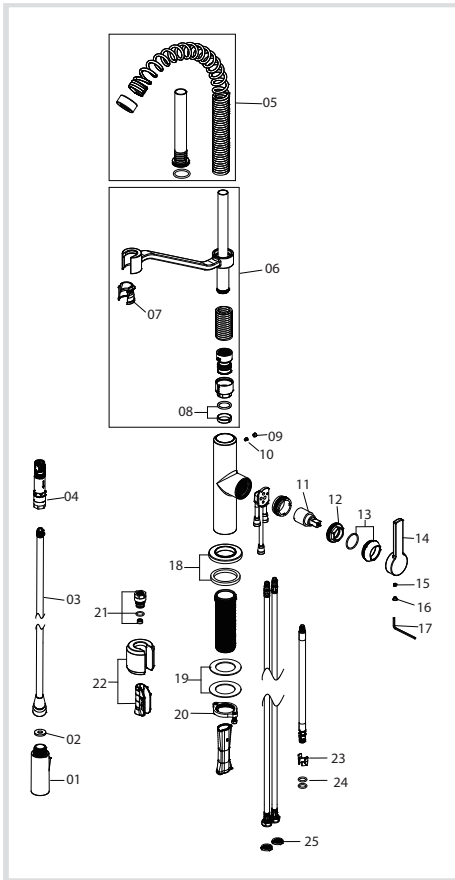

\*Denotes spray hose assembly color options:  
 Spray hose assembly color options:  
 Black hose with Matte Black connector (BLMB);  
 Gray hose with Spot-Free Stainless connector (GRSFS);  
 Black hose with Spot-Free Antique Champagne Bronze connector (BLSFACB)

\*\*Denotes faucet component color options:  
 SFS - Spot Free Stainless Steel  
 MB - Matte Black  
 SFACB - Spot Free Antique Champagne Bronze  
 SFSB - Spot Free Black Stainless  
 BB - Brushed Brass  
 MBSFSB - Matte Black/Spot Free Black Stainless  
 BBMB - Brushed Brass/Matte Black  
 GR - Grey  
 BL - Black

Replacement Parts List	Finish / Color	Part #
1. Spray Head	SFS, MB, SFACB**	KP27250
2. Sprayer Washer		KP27251
3. Sprayer Hose	GRSFS, BLMB, BLSFACB*	KP27252
4. Quick Connector Assembly		KP27090
5. Spring Assembly	SFS, MB, SFACB**	KP27322
6. Sprayer Holder Assembly	SFS, MB, SFACB**	KP27389
7. Inverter		KP27390
8. Wearable Ring & O-ring Assembly		KP27391
9. Index	GR, BL**	KP27222
10. Screw		KP27223
11. Cartridge		KP27069
12. Bonnet Nut		KP27202
13. Cap & O-Ring	SFS, MB, SFACB**	KP27203
14. Handle	SFS, MB, SFACB**	KP27204
15. Set Screw		KP27001
16. Cover Button	GR, BL**	KP27002
17. Hex Wrench		KP27020
18. Flange & Washer	SFS, MB, SFACB**	KP27205
19. Rubber & Metal Washer		KP27028
20. Mounting Nut & Screw		KP27079
21. 1.8GPM Flow Restrictor	White	KP27074
22. Weight & Clip Assembly		KP27236
23. Block		KP27073
24. O-Ring		KP27092
25. Filter Washer		KP27167



# Troubleshooting

If you have followed the instructions carefully and your faucet still does not work properly, take the following corrective steps:

PROBLEM	CAUSE	ACTION
Leakage under the handle.	Bonnet nut (12) has come loose.	Remove the cover button (16). Loosen set screw (15) with hex wrench (17). Remove the handle (14). Unscrew cap (13) (by hand only). Tighten bonnet nut (12) with an adjustable wrench.
The aerator has an irregular or reduced water flow.	The aerator is dirty or misfitted.	Remove the aerator and check for debris. Ensure that the rubber washer is properly installed.
Water will not shut off completely.	Cartridge may need to be adjusted or replaced.	Remove the cover button (16). Loosen set screw (15) with hex wrench (17). Remove the handle (14). Unscrew cap (13) (by hand only). Loosen the bonnet nut (12) with an adjustable wrench. Remove the cartridge (11). Check for cracks.
There is a low flow of water.	The filter washers in the hose connectors are dirty.	Turn off the water supply at the water valves and unscrew the hose connectors from the water supply lines. Clean the washers in the water lines with hot water, removing any debris or calcium build up.

## Codes/Standards Applicable:



ASME A112.18.1  
1.8GPM 6.8L/min maximum

### Faucet - Lifetime Limited Warranty

Kraus USA Plumbing, LLC ("Kraus") extends this warranty to the original purchaser for personal household use of the Faucet when purchased from an authorized Kraus dealer and in the location of original installation. This warranty is non-transferable.

Kraus warrants the structure and finish of the Faucet to be free from defects in material and workmanship under normal usage for as long as the original purchaser resides in the residence in which the Faucet was first installed.

Kraus warrants the Faucet's sprayhead assembly (including the engine, aerators, structure, restrictors, back flow preventers, sprayer hoses, braided supply line hoses which encompasses nylon, silicon and stainless steel) of the product to be free from defects in material and workmanship under normal usage for a period of one (1) year from the date of purchase.

Kraus warrants the Faucet's cartridge to be free from defects in material and workmanship under normal usage for a period of five (5) years from the date of purchase.

Any product reported to the authorized dealer or to Kraus as being defective within the warranty period will be repaired or replaced with a product of equal value at the option of Kraus.

### Commercial Warranty

Kraus USA Plumbing, LLC ("Kraus") warrants its Products for a period of one (1) year to commercial purchasers of Products used in industrial, commercial and business applications.

### Care and Cleaning Instructions

Certain cleaning products may cause damage to a Product's finish and use of the following on the Product will void this warranty:

- Abrasive cleaners such as powders, bleach, ammonia, alcohol or chlorine
- Abrasive pads, steel wool or wire brushes

### What is Not Covered

This warranty does not cover Products that were discontinued when purchased or display Products, whether such Products were purchased at discount outlets, unauthorized dealers, and/or sold on clearance. This warranty does not cover any free gifts included with purchase.

This warranty does not cover damage resulting from neglect, misuse (including use for an unintended application), abuse, carelessness, accident, hard water or mineral deposits, exposure to corrosive materials, improper maintenance, alteration of the Product, or failure to follow care, cleaning or installation instructions enclosed with your Product. Kraus recommends that all Kraus Products be installed by a fully licensed and insured trade professional with experience in the installation of bathroom and/or kitchen manufactured goods.

## How to Make a Warranty Claim

If you are a **consumer purchaser**, please contact a Kraus® Customer Service Representative at:

Kraus USA Plumbing, LLC  
12 Harbor Park Drive  
Port Washington, NY 11050  
Toll-free 800-775-0703  
Customerservice@kraususa.com

If you are a **plumbing contractor or trade professional**, please contact a Kraus Pro Representative at:

Kraus USA Plumbing, LLC  
12 Harbor Park Drive  
Port Washington, NY 11050  
516-801-8955  
Proservice@kraususa.com

If you are an **authorized partner**, please contact a Partner Support Representative at:

Kraus USA Plumbing, LLC  
12 Harbor Park Drive  
Port Washington, NY 11050  
516-801-8954  
Partnersupport@kraususa.com

In requesting warranty service, please be ready to provide your proof of purchase and a description of the problem. Shipping charges will be covered for the first (1) year of the warranted replacement part or product (HI, AK, and Puerto Rico shipping charges may apply). International shipping fees are not included.

## Limitation on Duration of Implied Warranties

Please note that some states/provinces (including Quebec) do not allow limitations on how long an implied warranty lasts, so the below limitations may not apply to you. TO THE MAXIMUM EXTENT PERMITTED BY APPLICABLE LAW, ANY IMPLIED WARRANTY, INCLUDING THE IMPLIED WARRANTIES OF MERCHANTABILITY AND OF FITNESS FOR A PARTICULAR PURPOSE, IS LIMITED TO THE STATUTORY PERIOD OR THE DURATION OF THIS WARRANTY, WHICHEVER IS SHORTER.

## Limitation of Special, Incidental or Consequential Damages

Please note that some states/provinces (including Quebec) do not allow the exclusion or limitation of special, incidental or consequential damages, so the below limitations and exclusions may not apply to you. TO THE MAXIMUM EXTENT PERMITTED BY APPLICABLE LAW, THIS WARRANTY DOES NOT COVER, AND KRAUS USA PLUMBING, LLC SHALL NOT BE LIABLE FOR, ANY SPECIAL, INCIDENTAL OR CONSEQUENTIAL DAMAGES (INCLUDING LABOR CHARGES TO REPAIR, REPLACE, INSTALL OR REMOVE THIS PRODUCT), WHETHER ARISING OUT OF BREACH OF ANY EXPRESS OR IMPLIED WARRANTY, BREACH OF CONTRACT, TORT, OR OTHERWISE.

This warranty gives you specific legal rights, and you may also have other rights which vary from state/province to state/province.

**Download the Kraus Care & Maintenance Guide at:**  
<http://www.kraususa.com/maintenance>

# IMPORTANT

## Register Your Kraus Product

**Activate** Your Warranty

**Access** Premium Customer Support

**Get** Product Information

**REGISTER TODAY**

<http://www.kraususa.com/registration>



**Kräus**<sup>®</sup>  
www.kraususa.com