

Kräus[®]

INSTALLATION GUIDE

Bolden™ Single Handle Pull Down Kitchen Faucet

KSF-1610

Congratulations on the purchase of your new Kraus plumbing fixture!

Please keep the box and packaging materials until your product is completely installed. If you have any questions, require technical assistance, or have any problems with your product:



DO NOT RETURN TO STORE

Please contact our Customer Service Team

1-800-775-0703 / customerservice@kraususa.com

Have the model number available, and retain a copy of your receipt with purchase date for reference.

If for any reason this product does not meet your expectations, please be sure to repack this product in the original box and packaging material to avoid damage during transit.

Prior to Installation:

- Make sure you have all necessary parts by checking the diagram and parts list. If any part is missing or damaged, please contact Kraus Customer Service at 800-775-0703 for a replacement
- Turn off the hot and cold water lines at the angle stops and turn on the old faucet to release any built-up pressure
- Pre-drilled countertop hole size requirement: 1-3/8"(min)
- Max countertop thickness: 3 3/8"

Tools you will need:

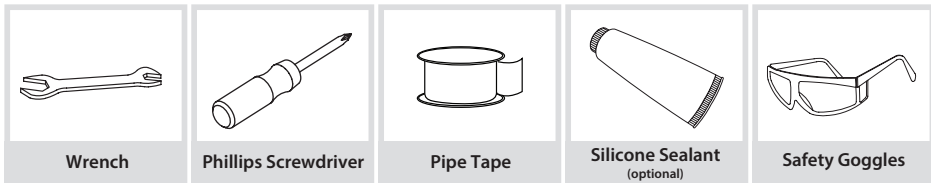
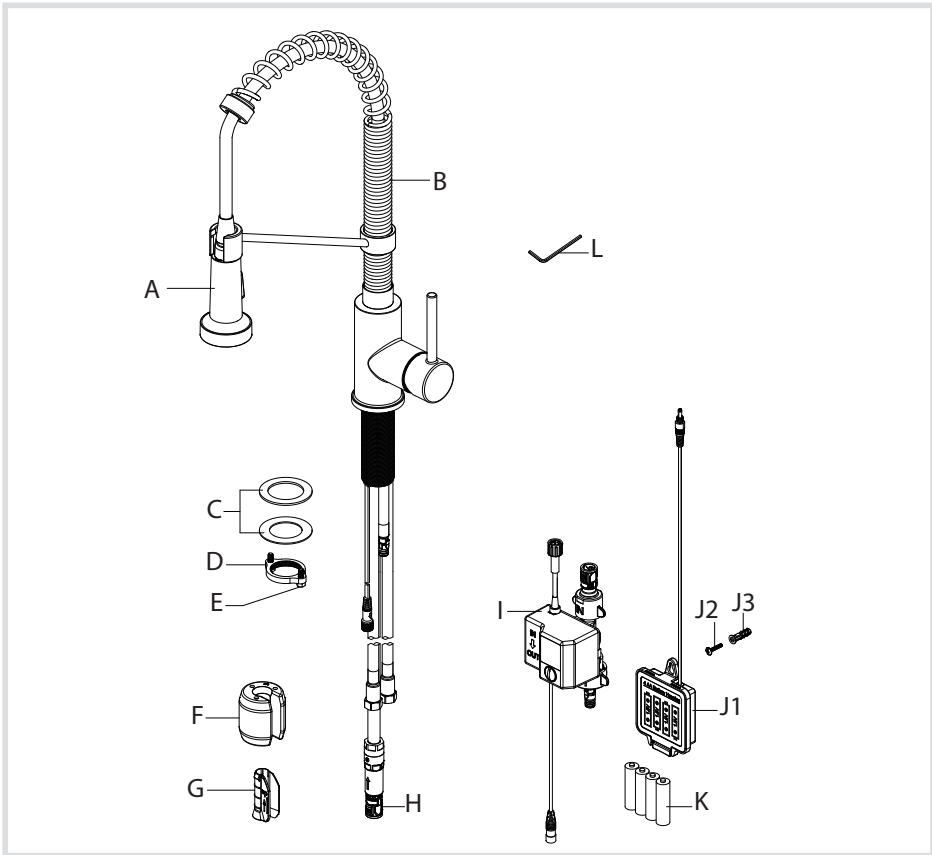

Diagram and Parts List



A. Spray Head
 B. Faucet Body
 C. Washers
 D. Mounting Nut
 E. Screws

F. Weight
 G. Weight Clip
 H. Quick Connector
 I. Sensor Control Box

J. Battery Pack
 J1. Battery Pack
 J2. Screw
 J3. Anchor
 K. Battery
 L. 2.5mm Hex Wrench

Faucet Dimension

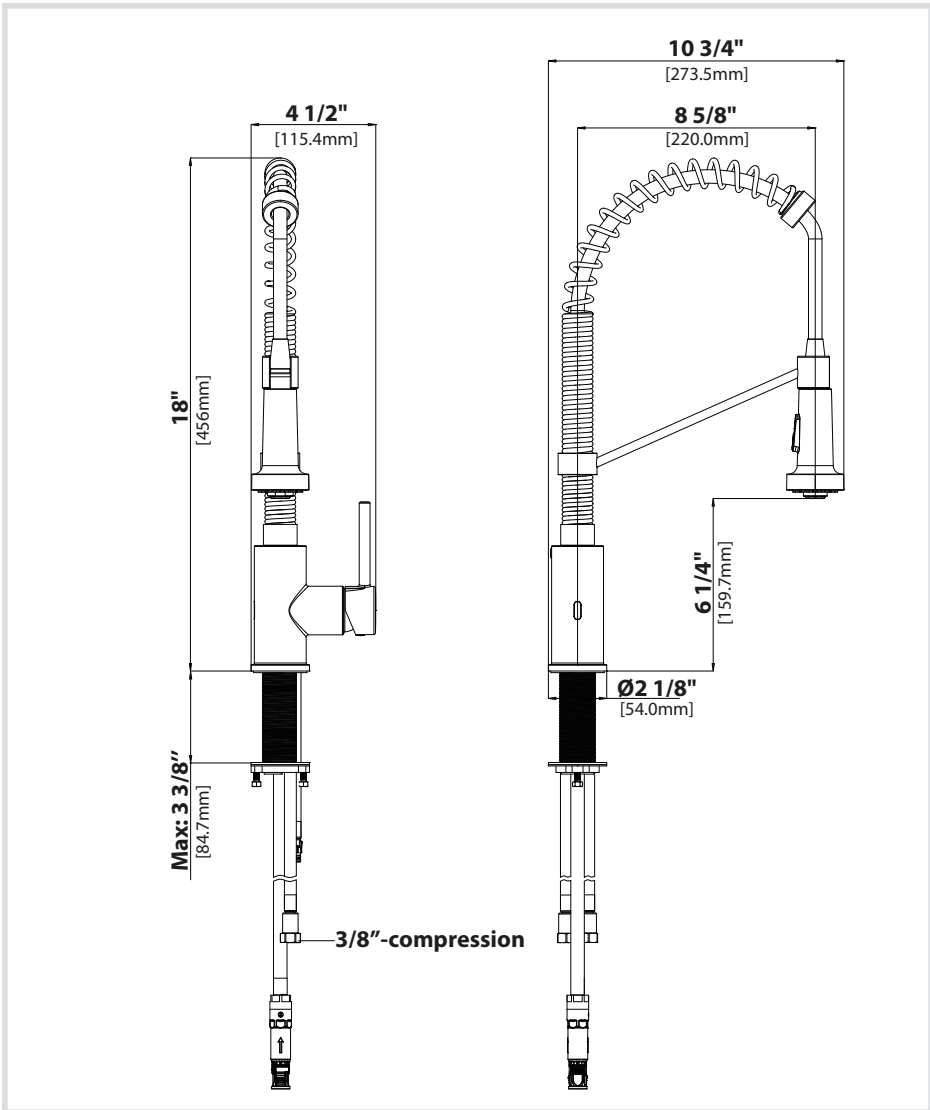

Installer Tip:

Shut off main water supply before installing new faucet

Step 1: Installing the faucet

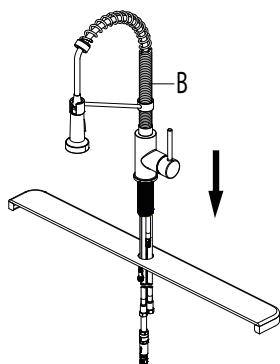

Shut off the water supply. Insert faucet body (B) through the hole in the sink.

Step 2: Securing the faucet assembly

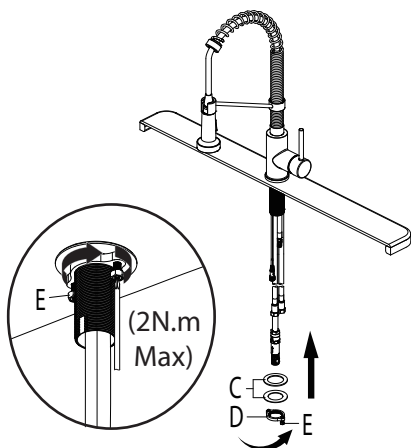

Install the washers (C) onto the threaded mounting shank. Thread the mounting nut (D) onto the mounting shank. Lock the mounting nut (D) into position by tightening the screws (E). Do not overtighten.

Step 3: Installing the sensor control box

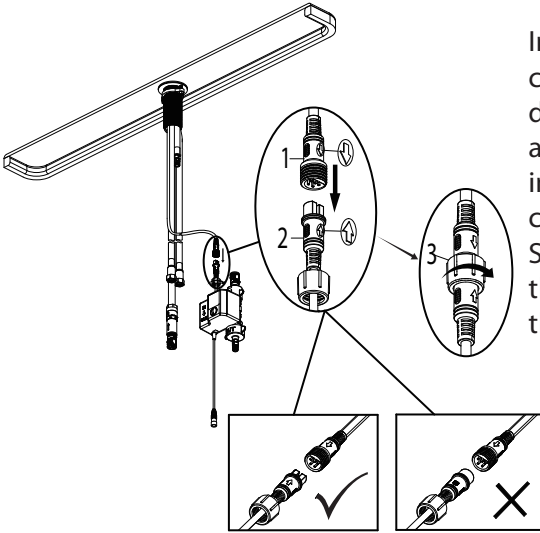

Install the data cable (1) to the control box connection (2). Ensure the arrows on the data cable and control box connection are aligned to one another to ensure proper installation. Ensure they are tightly connected by firmly pushing together. Secure the connection by hand tightening the nut (3) in a clockwise direction onto the threaded sensor cable.

CAUTION: If the connections are not made properly, the sensor feature will not work.

Step 4: Installing the sensor control box

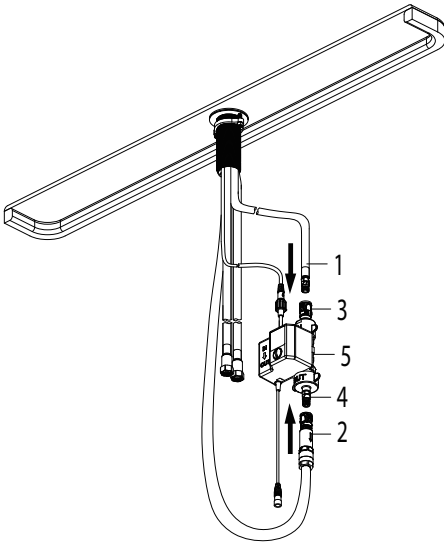

Connect the hose (1 & 2) to the connector (3 & 4) on the control box (5). Push firmly together until they snap into place.

Step 5: Securing the faucet assembly

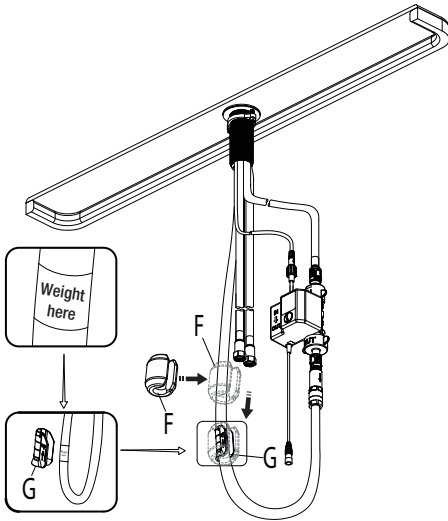

Install the weight clip (G) at the point of the hose marking "weight here". Insert the weight (F) onto the weight clip (G) by sliding it down onto the weight clip (G).

Step 6: Installing the battery pack

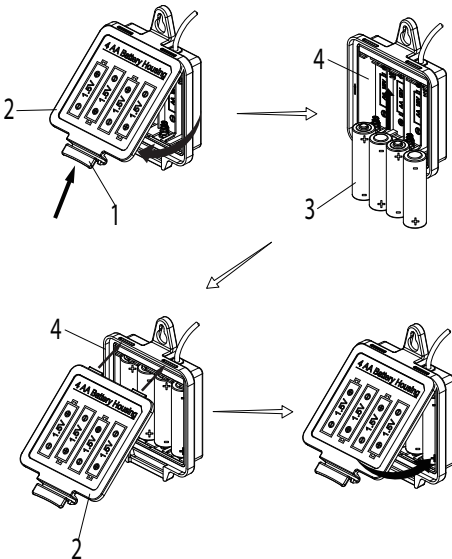

To open the battery housing, squeeze the tabs (1) on the cover (2), then remove the cover (2). Install the four AA batteries (3) included by matching the positive (+) and Negative (-) ends on the battery (3) to the (+) and (-) markings in the battery pack (4). The negative ends of the battery (3) should always connect to the spring end of the battery slots in the battery pack (4). Reinstall the battery pack cover (2) by pushing up and snapping into place.

NOTE: When the sensor flashes 10 times continuously and slowly, the batteries have lost their charge. Replace the batteries (3).

Step 7: Installing the battery pack

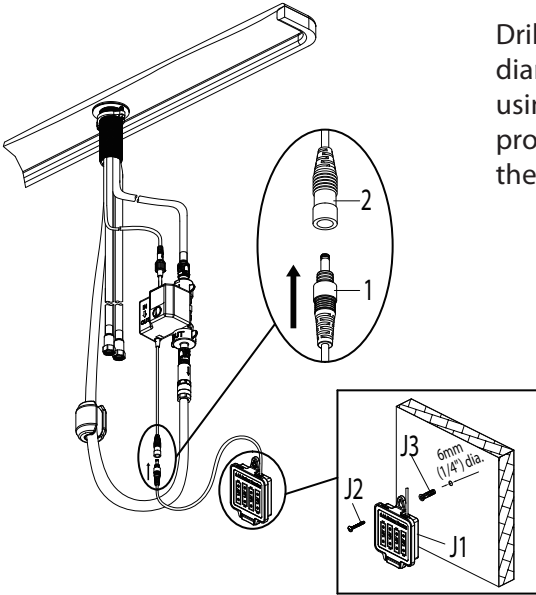

Drill a hole in the wall using a 6mm (1/4 in.) diameter drill bit. Install the battery pack (J1) using the molly anchor (J3) and screw (J2) provided. Insert the battery pack cable (1) into the control box connection (2).

NOTE: After installing the battery pack, the light on the sensor will flash and the faucet will sound when you move your hand in the sensor area. If not, check to ensure the batteries are installed correctly.

Step 8: Connect waterlines to main valve

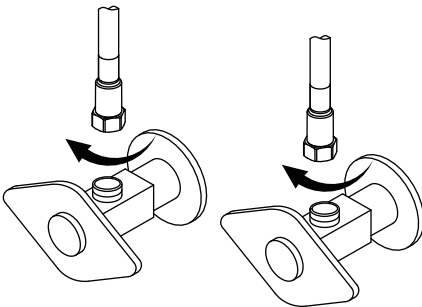

Attach waterlines to angle stops and tighten until snug. Turn on angles stops and check for leaks (**DO NOT TURN FAUCET ON**)

NOTE: Please make sure filter washers are installed before connecting to the main valve.

Step 9: Flush faucet

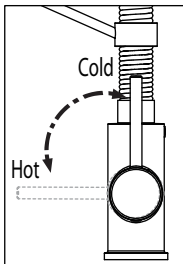
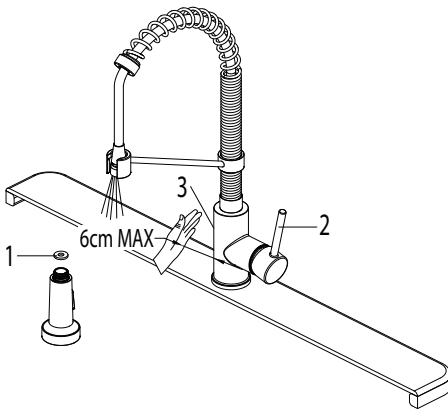

Flushing and checking for leaks: After the installation is complete, unscrew and remove the spray head in order to flush the line. Turn on the water supply and allow both hot and cold water to run for at least one minute each. This flushes away any debris that could cause damage to internal parts. Check for leaks. Re-attach the spray head. Do not lose the gasket (1) in the hose.

NOTE: Please make sure washer is installed attaching spray head to hose.

Operating the sensor: Turn the handle (2) away from the faucet to the full on position. Turn the water on by activating the sensor (3) by waving your hand within 6cm of the sensor. Move handle towards you and away from you, the water flow pattern can be switched from the hot water to cold water. If the sensor does not work, then you can refer to the troubleshooting. If you want to use the faucet without the sensor feature, then you can refer to troubleshooting 5. Then, turning on the water can be done by moving the handle away from the faucet to the full on position.

Note: The sensor is active only when the handle is in the ON position. As a water saving feature, the water will turn off automatically after 3 minutes of continuous flow.

Replacement Parts

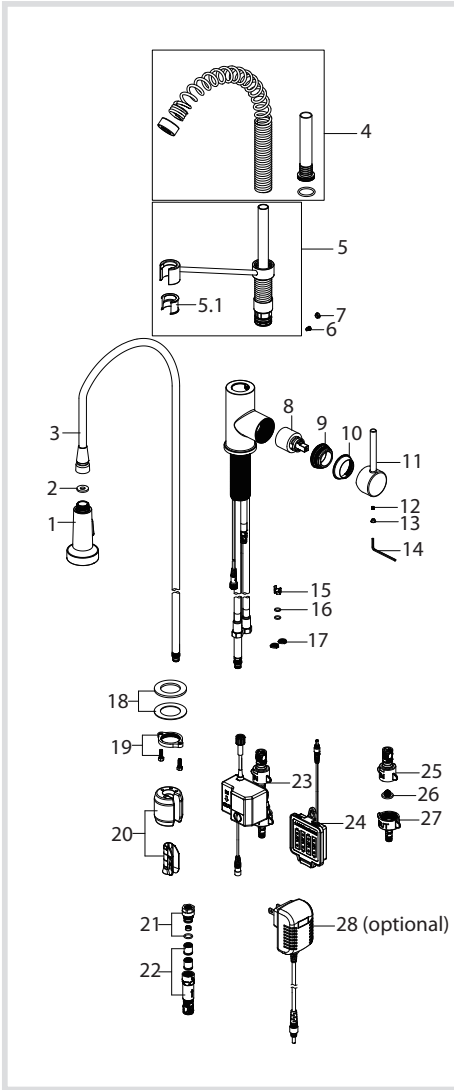

Replacement Parts List	Finish / Color	Part #
1. Sprayer Head	SFS, MB, SFACB, BB*	KP27216
2. Washer		KP27208
3. Sprayer Hose	BLMB, GRSFS, BLBB BLSFACB, BLSFS**	KP27217
4. Spring Assembly	SFACB, SFS, BB*	KP27322
4. Spring Assembly	MB*	KP27220
5. Sprayer Support Assembly	SFS, MB, SFACB, BB SFSMB, BBMB*	KP27218
5.1. Inverter		KP27245
6. Screw		KP27084
7. Index	BL, GR*	KP27124
8. Cartridge		KP27083
9. Bonnet Nut		KP27082
10. Cap	SFS, MB, SFACB, BB*	KP27081
11. Handle	SFS, MB, SFACB, BB*	KP27072
12. Screw		KP27001
13. Index	BL, GR*	KP27002
14. Hex Wrench		KP27020
15. Block		KP27073
16. O-Ring		KP27092
17. Filter Washer		KP27248
18. Washers		KP27028
19. Nut & Screw		KP27079
20. Weight & Clip Assembly		KP27236
21. 1.8GPM Flow Restrictor	WHITE	KP27074-WH
22. Quick Connector Assembly		KP27090
23. Control Box		KP27186
24. Battery Housing		KP27188
25. Inlet Connector		KP27190
26. Filter Washer		KP27189
27. Outlet Connector		KP27191
28. AC Adapter (optional)		KP27187

*Denotes spray hose assembly color options:

Spray hose assembly color options:

Black hose w/ Matte Black connector (BLMB); Black hose with Brushed Brass connector (BLBB);

Gray hose with Spot-Free Stainless connector (GRSFS); Black hose with Spot-Free Stainless connector (BLSFS);

Black hose with Spot-Free Antique Champagne Bronze connector (BLSFACB);

*Denotes faucet component color options:

SFS - Spot Free Stainless Steel ; MB - Matte Black; SFSMB - Spot Free Stainless Steel/Matte Black

SFACB - Spot Free Antique Champagne Bronze; BBMB - Brushed Brass/Matte Black

GR - Grey; BL - Black BB - Brushed Brass

Troubleshooting

If you have followed the instructions carefully and your faucet still does not work properly, take the following corrective steps:

Problem 1: Water will not shut off when turning the handle to the OFF position.

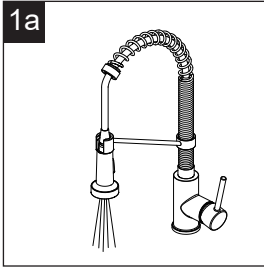

When you turn the handle to the full on position, the water will turn on.

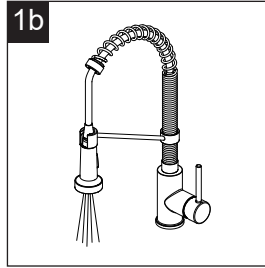

But when you turn the handle to the full off position, the water does not turn off.

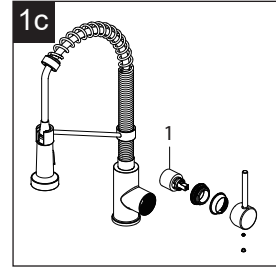

This indicates that the cartridge is damaged. Turn off the water supply, remove the handle and replace the cartridge (1).

Problem 2: The light on the sensor is flashing continuously.

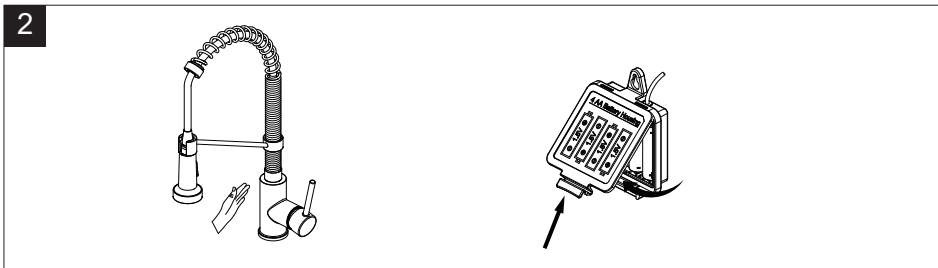

If the handle is closed, turn the handle to the on position and move your hand in the sensor area. If the sensor flashes 10 times continuously and slowly, then replace the 4 "AA" batteries.

Problem 3: There is a low flow of water or LED indicator in the faucet body is not functioning.

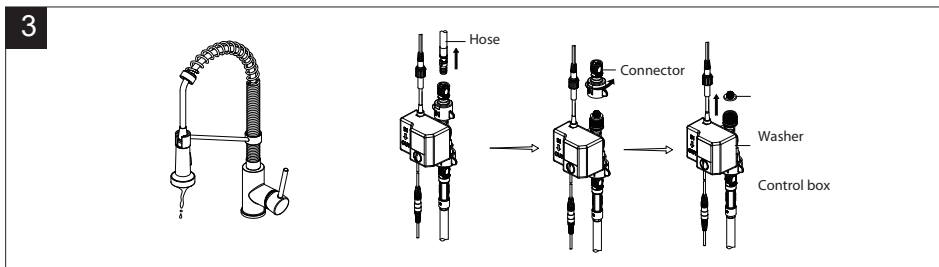

a. This could indicate that the washer in the control box is dirty or damaged. Remove the hose and unscrew the connector. Take out the washer from the control box. Clean the washer or replace the washer. Reassemble the connector and hose.

b. The filter washer (17) in the hose connectors is dirty. Turn off the water supply at water valve and unscrew the hose connectors from water supply lines. Clean the filter washer in the water lines with hot water, removing any debris or calcium build up.

Problem 4: The sensor is not activating the water flow.

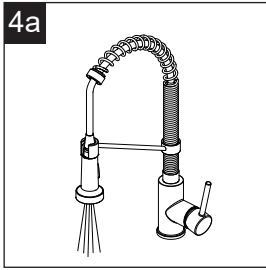

When you turn the handle to the full on position, the water will turn on.

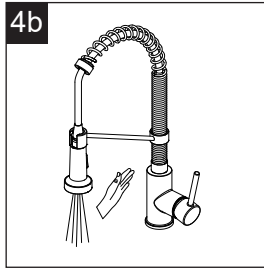

However, when you move your hand in front of the sensor, the water does not turn off as it should.

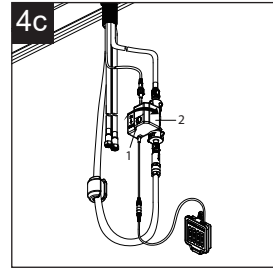

Check whether the switch button (1) is tighten, if it is loose, tight the switch button (1) completely with a coin clockwise. If the switch button (1) is tighten, this indicates that the control box (2) is damaged. Call customer service to request a replacement control box. Replace the old control box with the new control box.

Problem 5: The function of the switch button.

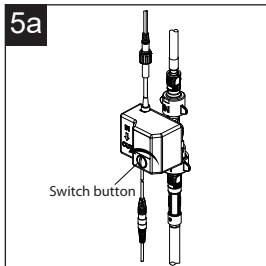

If you want to use the faucet without the sensor feature, you can loose the switch button completely with a coin counterclockwise. At this time, you can use the sensor faucet as the use of the common faucet.

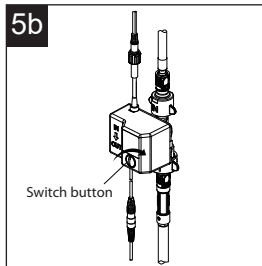

However, if you want to continue to use the faucet with the sensor feature, you need tight the switch button completely with a coin clockwise. At this time, you can use the faucet with the sensor feature.

Care & Maintenance

*To keep the product clean & shining, follow the steps below:

1. Rinse with clean water & dry with a soft cloth
2. Do not clean with soaps, acid, polish, abrasives, or harsh cleaners
3. Do not use cloth with a coarse surface
4. Unscrew the aerator and clean when necessary

*This installation manual is subject to change without further notice.



Codes/Standards Applicable:



NSF/ANSI 61



ASME A112.18.1
1.8GPM 6.8L/min maximum

Faucet Warranty

Kraus products are manufactured and tested to the highest quality standards by Kraus USA Inc. ("Kraus"). Kraus extends this warranty to the original purchaser for personal household use of the "Faucet" in its original location. The warranty is non-transferable.

Kraus warrants the structure and finish of the product to be free from defects in material and workmanship under normal usage for the lifetime of the product. The warranty commences from the initial date of purchase by the owner or trade professional, from an authorized Kraus dealer, through the lifetime of the original owner or end-user.

Kraus warrants the mechanical components such as but not limited to sprayhead assembly (includes engine, aerators, structure, restrictors, back flow preventers, sprayer hoses, braided supply line hoses which encompasses nylon, silicon and stainless steel, etc) of the product to be free from defects in material and workmanship under normal usage for a period of one (1) year. The warranty commences from the initial date of purchase by the owner or trade professional, from an authorized Kraus dealer, through the one (1) year term of the original owner or end-user.

Kraus warrants the mechanical component (cartridge) of the product to be free from defects in material and workmanship under normal usage for a period of five (5) years. The warranty commences from the initial date of purchase by the owner or trade professional, from an authorized Kraus dealer, through the five (5) years term of the original owner or end-user.

Kraus warrants all electronic parts other than batteries to be free from defects in material and workmanship for a period of two (2) years. The warranty commences from the initial date of purchase by the owner or trade professional, from an authorized Kraus dealer, through the two (2) year term of the original owner or end-user. No warranty is provided on batteries.

Any product reported to the authorized dealer or to Kraus as being defective within the warranty period will be repaired or replaced with a product of equal value at the option of Kraus. This warranty extends to the original owner or end-user, and is not transferable to a subsequent owner.

Restrictions

This warranty does not cover antediluvian, discontinued, or display products, whether such items are purchased at discount outlets, unauthorized dealers, and/or sold on clearance.

This warranty does not cover instances of negligence, misuse, abuse, improper installation, carelessness, accident, hard water or mineral deposits, exposure to corrosive materials, misapplication, damages caused by improper maintenance, alteration of the product, or failure to follow care or installation instructions enclosed with your product. Avoid using abrasive cleaners such as powders, bleach, ammonia, alcohol, or chlorine. Avoid using abrasive pads, steel wool, or wire brushes, as these will damage and wear down the finish.

This warranty does not apply to Products that have not been installed or operated in accordance with instructions supplied by Kraus and all applicable rules, regulations, and legislation pertaining to such installations.

This warranty does not apply unless the Kraus product is installed by a fully insured and licensed trade professional. Kraus insists that such professionals have experience in the installation of bathroom and kitchen manufactured goods.

This warranty does not cover labor charges or costs of removal and reinstallation of said product. This warranty does not allow recovery of incidental or consequential damages, such as loss of use, delay, property damage, or other consequential damages, and Kraus accepts no liability for such damages.

This warranty does not cover Marine or Outdoor Installation.

Except as otherwise provided above, Kraus makes no warranties, expressed or implied, including warranties of merchantability and fitness for a particular purpose, or compliance with any code.

Shipping charges will be covered for the first (1) year of the warranted replacement part or product (HI, AK, and Puerto Rico shipping charges may apply). International shipping fees are not included.

Commercial Warranty

Kraus extends the above warranty for a period of one (1) year to purchasers of products for industrial, commercial, and business use.

All incidental or consequential damages are specifically excluded. No additional warranties, express or implied, are given, including but not limited to any implied warranty of merchantability or fitness for a particular purpose. Some states do not allow the exclusion or limitation of incidental or consequential damages or limitations on how long an implied warranty lasts, so the above limitations or exclusions may not apply to you. This warranty gives you specific legal rights, and you may also have other rights which vary from state to state.

If you are a homeowner please contact a Kraus Customer Service Representative at:

Kraus USA, Inc.
12 Harbor Park Drive
Port Washington, NY 11050
Toll-free 800-775-0703
Customerservice@kraususa.com

If you are a plumbing contractor or trade professional please contact a Kraus Pro Representative at:

Kraus USA, Inc.
12 Harbor Park Drive
Port Washington, NY 11050
516-801-8955
Proservice@kraususa.com

If you are an Authorized Partner please contact a Partner Support Representative at:

Kraus USA, Inc.
12 Harbor Park Drive
Port Washington, NY 11050
516-801-8954
Partnersupport@kraususa.com

In requesting warranty service, please be ready to provide:

1. Proof of purchase.
2. A description of the problem.

Download the Kraus Care & Maintenance Guide at:

<http://www.kraususa.com/maintenance>

IMPORTANT

Register Your Kraus Product

Activate Your Warranty

Access Premium Customer Support

Get Product Information

REGISTER TODAY

<http://www.kraususa.com/registration>



Kräus[®]
www.kraususa.com