

8 FILEBOX STORAGE RACK Assembly instructions

TOOLS REQUIRED

1. Drill with #2 Phillips-Head bit



PARTS LIST

1. 8 x Horizontal crossbars
2. 2 x Center verticals
3. 4 x Corner verticals
4. 6 x Vertical top caps
5. 4 x Front and rear grid connecting tubes
6. 4 x Wall mount brackets
7. 8 x Horizontal slide rails

FASTENER LIST

1. 48 x #06 x 1/2 in. fastening screws
2. 08 x #10 x 1-1/4 in. fastening screws
3. 08 x Plastic wall anchors

NOTE

HARDWARE IS LOCATED IN THE TUBES.

Separate all parts into groups (as shown) and familiarize.

Read all instructions before beginning assembly.

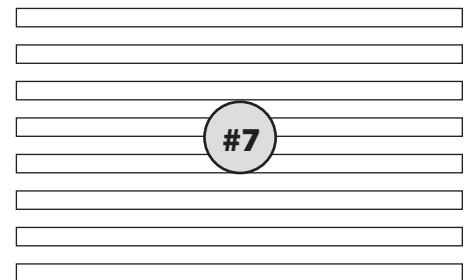
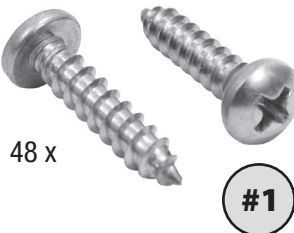
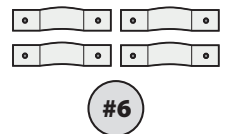
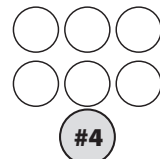
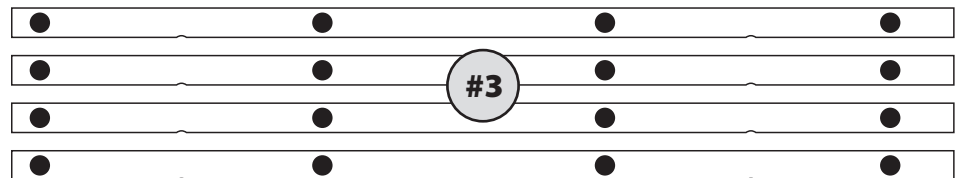
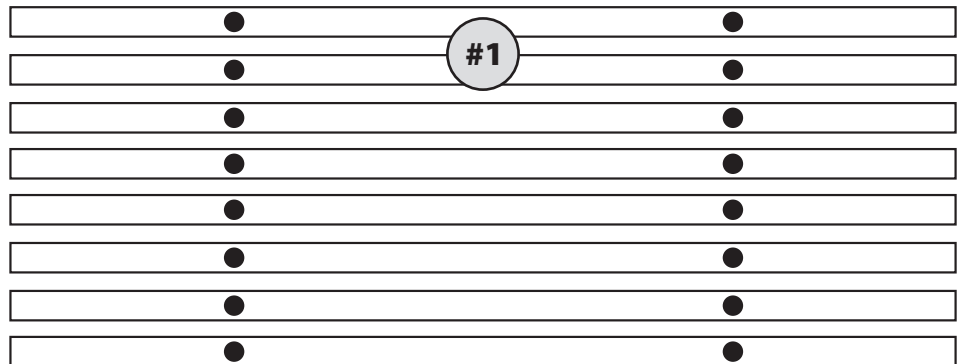

FRONT GRID ASSEMBLY

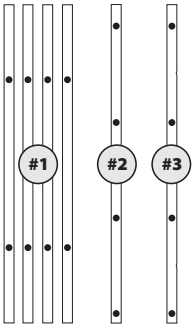

Parts needed:

4 of #1 2 of #3
1 of #2

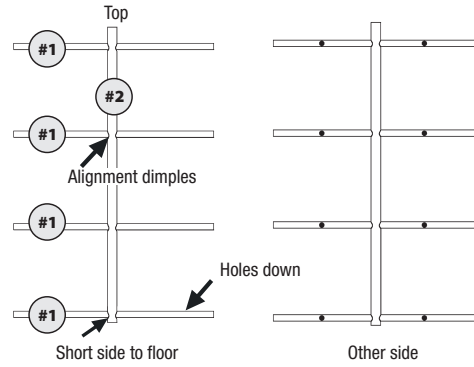

STEP 1

4 Horizontal crossbars (#1) inserted through 1 Center Vertical (#2) **Note: Slide horizontal crossbar into left side of center vertical following direction of arrow until alignment dimple meets center vertical.**

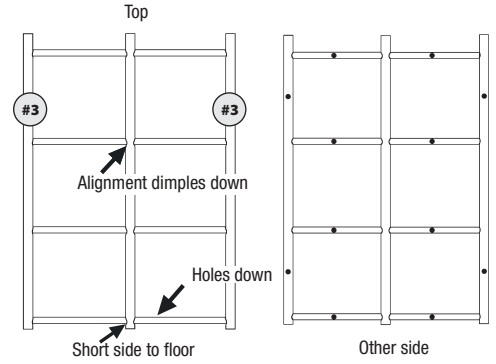

STEP 2

Two corner vertical (#3) inserted through horizontal crossbars

REAR GRID ASSEMBLY

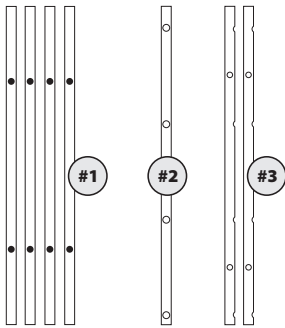

PARTS NEEDED:

4 of #1 1 of #2
2 of #3

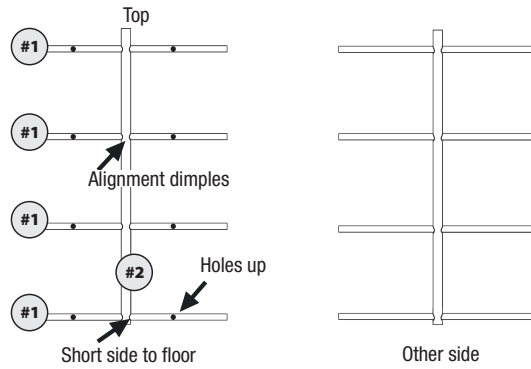

STEP 1

4 Horizontal Crossbars (#1) inserted through one center vertical (#2) **Note: Slide horizontal crossbar into right side of center vertical following direction of arrow until alignment dimple meets center vertical.**

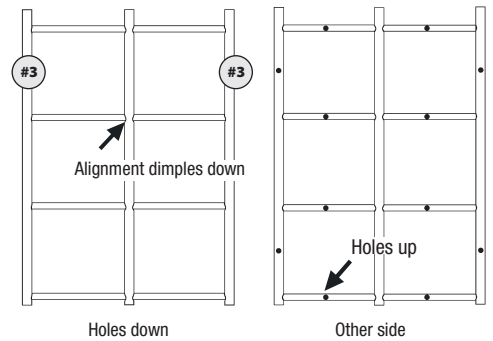

STEP 2

2 Corner verticals (#3) placed on horizontal crossbars.

SLIDE RAIL ASSEMBLY TO REAR GRID

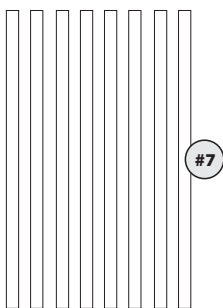

PARTS NEEDED

8 of #7

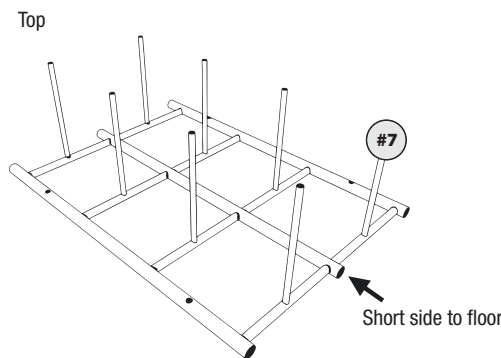

STEP 1

8 Horizontal slide rails (#7) inserted in rear grid.

Tip: If necessary, tap horizontal slide rails to be sure slide rails are fully inserted.

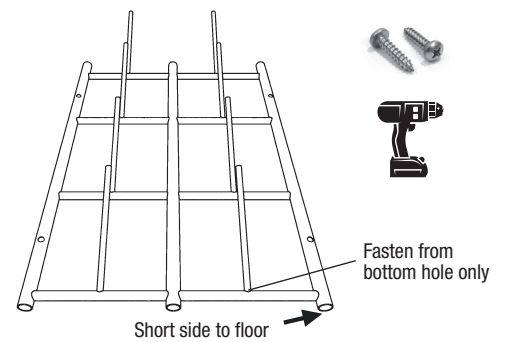

STEP 2

Fastening horizontal slide rails (#7) in rear grid using 8 – #06 x 1/2 in. fastening screws (#1).

Note: Start at top row and work down. Use only one fastener – bottom hole only.

JOINING FRONT TO REAR GRID

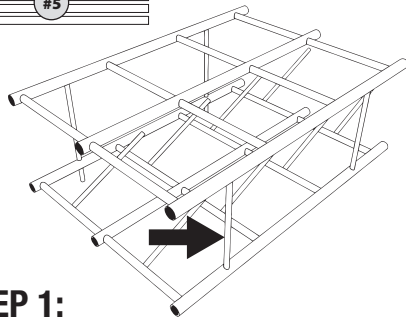

STEP 1:

Join front to rear grid by inserting 4 front & rear grid connecting tubes (#5) into front grid assembly
Note: Do not fasten at this time

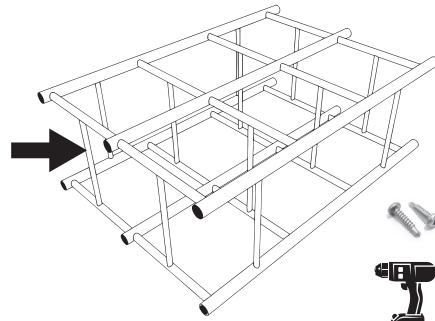

STEP 2:

Insert and fasten 8 horizontal slide rails (#7) into front grid assembly using 8 – #06 x ½ in. fastening screws (#1). **Note: Fasteners in bottom hole only, work from bottom row to top row**

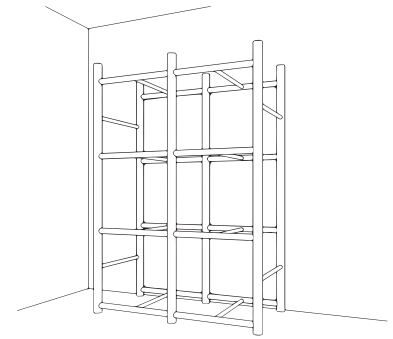

STEP 3:

Turn unit upright and place firmly against wall where unit is to be mounted.

FASTENING VERTICALS & FRONT & REAR GRID CONNECTING TUBES

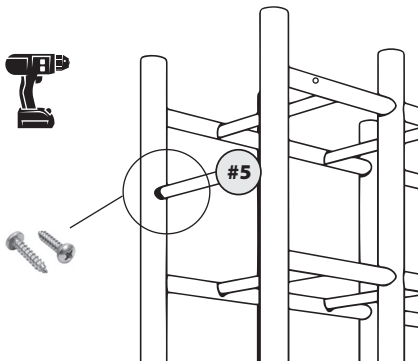

STEP 1:

Fasten 4 front & rear grid connecting tubes (#5) to front grid assembly using 8 – #06 x ½ in. fastening screws (#1).

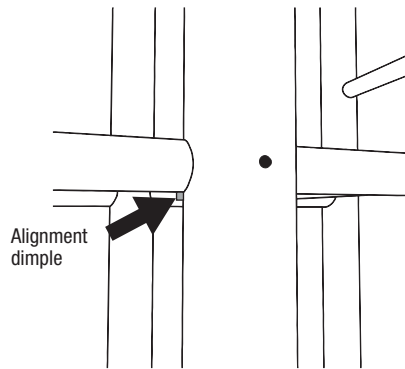

STEP 2:

Make sure unit is straight and square, and all verticals are pressed firmly together and against alignment dimples.

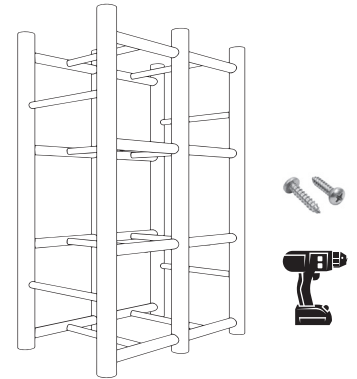

STEP 3:

Fasten all verticals to horizontals making sure all joints are pressed firmly together and tight against alignment dimples using 24 – #06 x ½ in. fastening screws (#1)
Note: Fasteners in holes facing YOU only.

FASTENING TO WALL

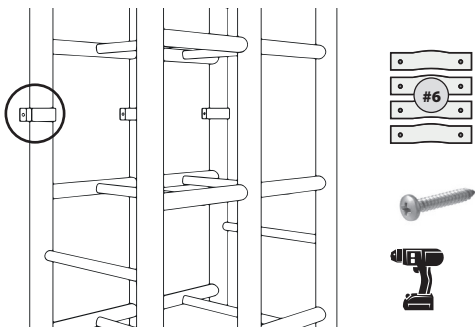

Place 4 wall mount bracket (#06) over 4 rear verticals above 2nd horizontal crossbar (#1) and fasten to wall using 8 – #10 x 1¼ fastening screws. (#2).

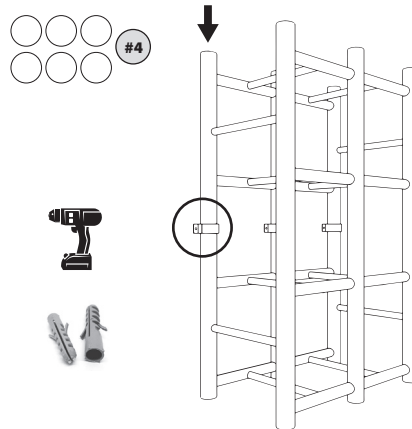

Note: If mounting into drywall or masonry, mark and drill ¼ holes and insert plastic wall anchors – and proceed with step 1 – Insert decorative top caps (#4) into all verticals.



Unit must be attached to wall to keep from tipping over! Congratulations! We hope you enjoy your Bin Warehouse file box storage rack!

Warranty – Bin Warehouse PVC Rack

This Lifetime Warranty extends only to the first retail purchaser of Proslat Bin Warehouse product(s)

Lifetime Warranty.

This document details the Solutions Murales PROSLAT inc. Warranty for all new Proslat Bin Warehouse product purchased anywhere in continental USA and Canada. Solutions Murales PROSLAT inc. (hereafter Proslat) warrants its Bin Warehouse Rack against defects in material or workmanship for a lifetime period. Proslat will replace any defective Rack as long as it was installed and maintained according to the printed instructions. Any Proslat Bin Warehouse Rack replaced under the terms of the Lifetime Warranty inherits the remaining warranty period from the original purchase.

Exclusions.

The Proslat Warranty does not cover the following: – Damage that results from improper installation or misuse or abuse; – Damage due to acts of God, fire, or accident; – Damage that results from loading the rack beyond the stated maximum weight capacity; – The cost of labor or accessory materials; and shipping cost to return defective products.

Limitations of Warranty.

The above Lifetime Warranty is the exclusive warranty for Proslat Bin Warehouse product. Proslat disclaims all other warranties, express or implied, including any implied warranties or merchantability, fitness for particular purpose or otherwise. If you live in an area where consumer law prohibits this disclaimer, the above Lifetime Warranty will not extend the time period of any such implied warranty.

Obtaining Lifetime Warranty Service. For warranty service, call 1.888.691.2944. You will need your original proof of purchase and photos to illustrate the claimed defect.

DISCLAIMER OF LIABILITY

Solutions Murales PROSLAT inc. and its successors, distributors and dealers (hereafter SELLER) shall in no way be responsible for the product's proper use and service. THE BUYER HEREBY WAIVES ALL LIABILITY CLAIMS. The BUYER acknowledges that he/she is not relying on the SELLER's skill or judgment to select or furnish goods suitable for any particular purpose and that there are no liabilities which extend beyond the description on the face hereof and the BUYER hereby waives all remedies or liabilities, expressed or implied, arising by law or otherwise, (including without any obligations of the SELLER with respect to merchantability and consequential damages) or whether or not occasioned by the SELLER's negligence. The SELLER disclaims any warranty and expressly disclaims any liability for personal injury or damages. The BUYER acknowledges and agrees that the disclaimer of any liability for personal injury is a material term for this agreement and the BUYER agrees to indemnify the SELLER and to hold the SELLER harmless from any claim related to the item of the equipment purchased. Under no circumstances will the SELLER be liable for any damages or expenses by reason of use or sale of any such equipment. The SELLER assumes no liability regarding the improper installation or misapplication of its products. It is the installer's responsibility to check for proper installation and if in doubt, contact the manufacturer. These assembly guidelines will direct you through the process of assembling a section of Solutions Murales PROSLAT inc. product. Please keep in mind that they may not cover every assembly or installation scenario you may encounter. Since each installation is unique in its performance requirements, the ultimate installation method used is the sole responsibility of the installer. Solutions Murales PROSLAT inc. disclaims any liability or responsibility for the improper installation of this product. The purchaser is solely responsible for compliance with applicable local codes. Solutions Murales PROSLAT inc. recommends that all designs be reviewed by a licensed architect, engineer or local building official before installation.



Questions, problems, missing parts? Before returning to the store, call
Proslat Customer Service — 8 a.m. – 5 p.m., EST, Monday – Friday

1-888-691-2944
info@proslat.com
www.proslat.com

Retain this manual for future use.