

Warning: Our pipes are illegal for EPA, CALIFORNIA and CARB. Only for off-road racing use.

Warning: Checking with your local state and Federal Laws before you take any action on your bike. Our true dual headers are only for off-road using, not for street riding. Please note.

SUGGESTED TOOLS:



15MM LONG HANDLE SOCKET

6MM HEX DRIVER



8MM WRENCH



13MM REGULAR SOCKET WITH EXTENSION

HDEX-12 (TRUE DUAL HEADER) FOR 2009-2016 HARLEY TOURING MODELS

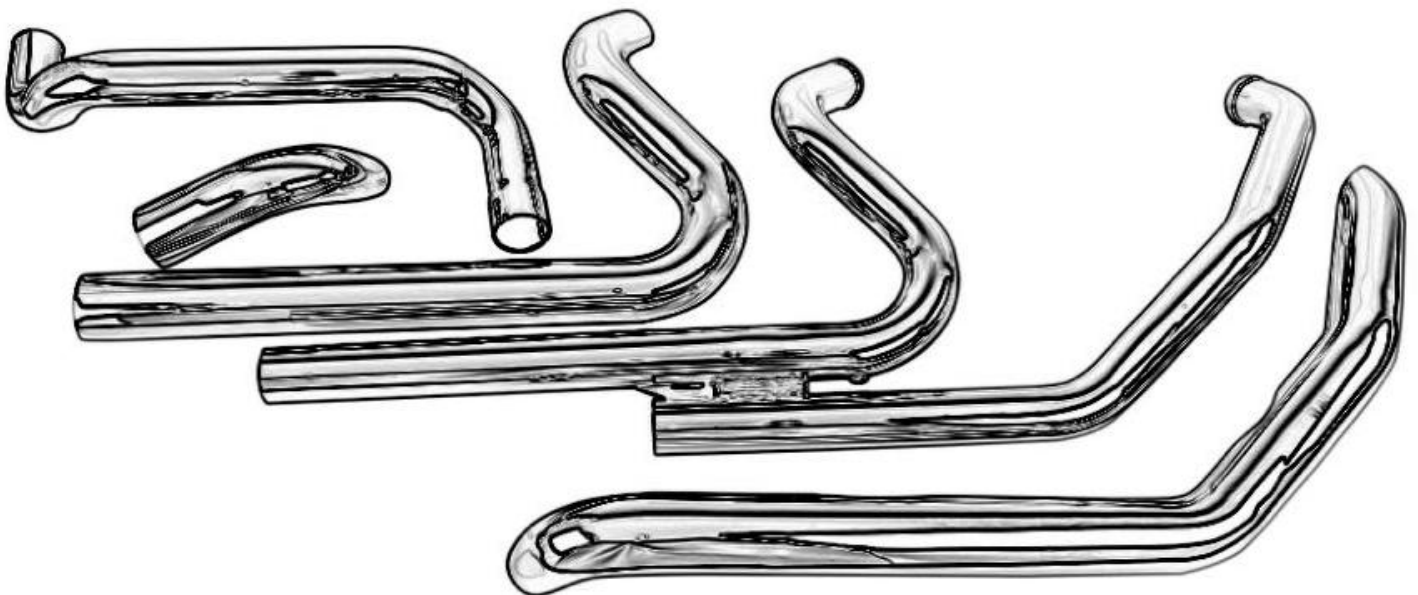

ITEM SUPPLIED:

- 1- EXHAUST HEADER BODY
- 1- CROSSOVER PIPE
- 3- HEAT SHIELD
- 1- A PACK OF HARDWARE
- 1- INSTALLATION INSTRUCTION

FITMENT:

2009-2016 HARLEY TOURING MODELS

**EXCEPT Trike Models
(Torque Cone Sold Separated)**

ALL PARTS LIST

NO.	ITEM	DETAILS	QTY
1	Exhaust-Section 1		1 PCE
2	Exhaust-Section 2		1 PCE
3	Heat Shield-Section 1		1 PCE
4	Heat Shield-Section2		1 PCE
5	Heat Shield-Section3		1 PCE
6	AC-03	Gasket*2+Flange*2 Snap Ring*2+Nuts*4	1 SET
7	O2 Sensor Transfer	18mm~12mm	2 PCS
8	Carriage Bolt & Nut	Bolt-3/8-16*3/4 Nut-3/8-16	1 SET
9	Bracket		1 PCE
10	P Clamp for Header	SMALL	1 PCE
11	12mm-O2 Sensor Plug	6mm(=7/32" Allen Head)	2 PCS
12	18mm-O2 Sensor Plug	8mm(=5/16" Allen Head)	2 PCS
13	Nut for Small P Clamp	1/4-20	1 PCE
14	Bolts for Small P Clamp	1/4-20*3/4	3 PCE
15	P Clamp for Crossover Pipe	BIG	1 PCE
16	Hose Clamp	27-51mm	8 PCS
17	Exhaust Clamp	48-51mm	1 PCE
18	Aluminum Spacer	L19*1.D.-10*O.D.-16mm	2 PCS
19	Flat Washer	M10	2 PCS
20	Bolt	3/8-16*2	1 PCE
21	Bolt	3/8-16*3-1/2"	1 PCE

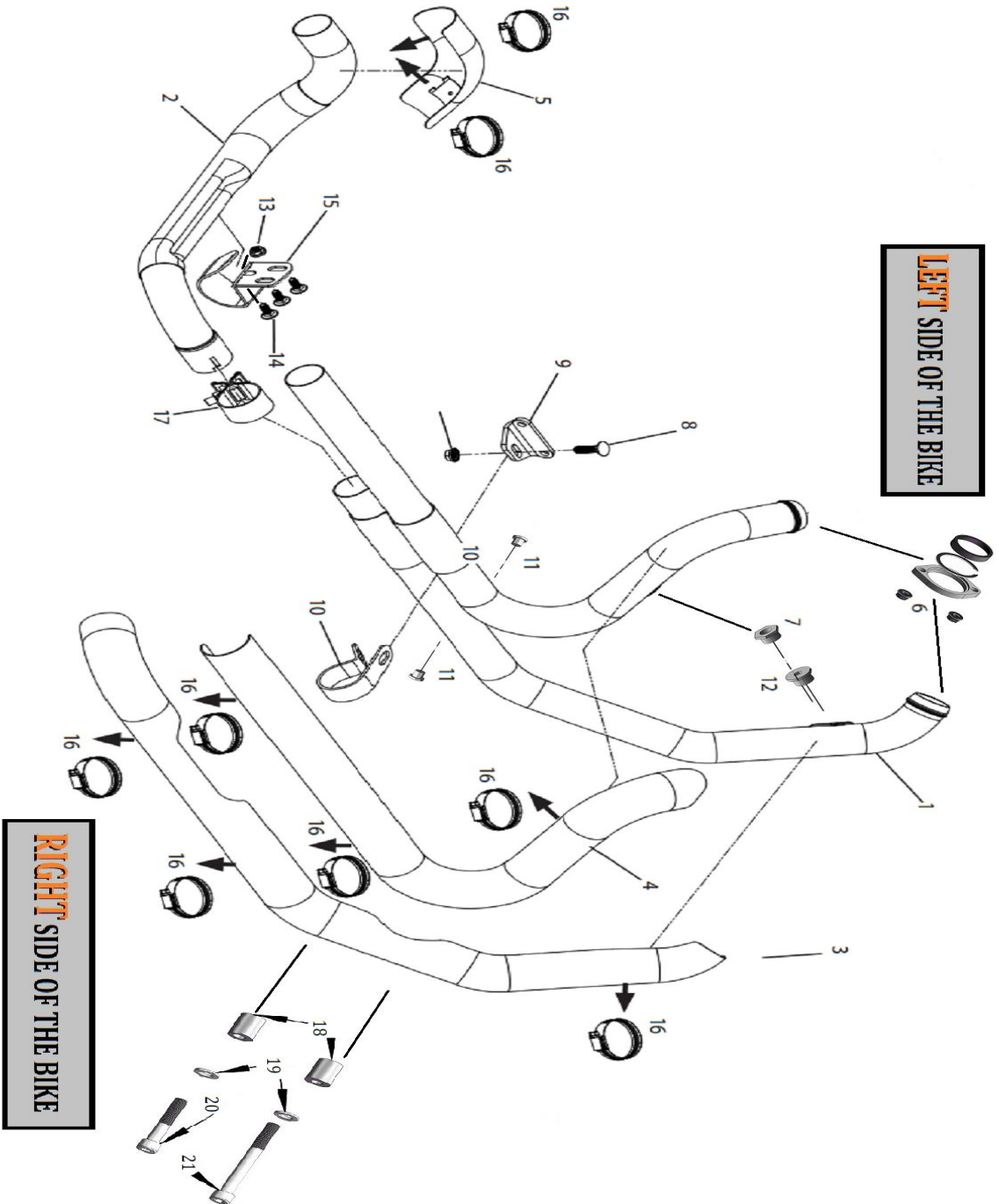

Make sure that THE BIKE is completely cooled down before ANY OPERATION.

INSTALLATION INSTRUCTIONS

TRUE DUAL HEADERS FOR 2009-2016 HARLEY TOURING MODELS:

Please use the bolts and nuts come with the pipes.

1. Before taking any action on your bike, please make sure that it is parked correctly to prevent it from falling down while you are pulling or installing the exhausts.

Note: We cannot be held responsible for any injuries that may occur during the installation of pipes or exhausts, as it may vary depending on the condition of the bike or the work site.

2. Before installing the new TRUE DUAL HEADER exhaust system, we need to first remove the entire stock exhaust system.

3. Release the quarter-turn pins (2 pins/bag) of the saddlebags, then remove the saddlebags carefully. Put them on a carpet or some sort of soft surface from scratching. (Shown in **Figure 1**)

4. Use a 13mm (1/2") regular socket to loosen the nuts for exhaust hangers holding the mufflers. (Shown in **Figure 2**)
Use a 15mm (9/16") long handle socket to loosen the exhaust clamps for muffler inlets fixed. (Shown in **Figure 3**)

5. Carefully remove the muffler without hurting the head pipes; Slightly twist it and pull the muffler out until it slides off the head pipe. Remove both left and right side mufflers and put them aside. Put them on a carpet or some sort of soft surface from scratching. (Shown in **Figure 4/5**)

6. All right. Now we will use a 8mm (5/16") hex head with a 15mm (9/16") wrench to remove the floorboard for foot on the engine port side of the bike. They may in the way of removing the old headers or installing the new one. (Shown in **Figure 6 / 7**)

7. Now, we need to use a 15mm (9/16") long handle socket to loosen the stock bracket for supporting crossover pipe. (Shown in **Figure 8**) Remove the part away when nuts off. (Shown in **Figure 9**)

8. Then, now we can start to detach the clamp for the header system to the crossover pipe. Use a 16 mm (5/8") socket to loosen the nuts next to the crossover pipe bracket we just removed. (Shown in **Figure 10**) Then carefully disconnect the crossover pipe.

9. Next, use a 5mm (3/16") hex-head Allen to remove the stock underneath bracket for crossover pipe. (Shown in **Figure 11**)

10. Before we are able to remove the whole old header system, we need to open the side panel to unplug the O2 sensor wires and let the wire out with the exhaust system. (Shown in **Figure 12/13**)

NOTE: GRAY O2 SENSOR WIRE- for FRONT HEADER. BLACK O2 SENSOR WIRE- for REAR HEADER. Make sure put them back on new headers in the correct order later.

11. Now, please get a extension with a 13mm (1/2") socket to remove the old flange nuts. (Shown in **Figure 14 & Figure 15**)

12. The last step before we can remove the whole old header system is to remove the long flat top bolt main support near the oem catalytic converter. Use a 15mm (9/16") socket to remove the bolt. (Shown in **Figure 16/17**)

13. Finally, with everything released. Now we can get the whole old header system off the bike. (Shown in **Figure 18**)

14. It's time to remove the stock O2 sensor wires from the old system using a 14mm (9/16") wrench for a 12mm O2 sensor. You'll need these wires for the new system later. Please be careful when unscrew the end. (Shown in **Figure 19/20**)

Note: If your O2 sensor wire is a 18mm wider one, please use a 22mm (7/8") wrench to disconnect it.

15. Before proceeding with the new 2-1 exhaust system, be sure to remove the stock bracket. Instead, use the new bracket provided to support the new 2-1 exhaust system. 1/4" Hex-head wrench is applied for the stock bolts. (Shown in **Figure 21/22**)

16. Additionally, it's important to use marker pens to mark the positions for hose clamps on the exhaust body. Doing so will make it much easier to install the heat shield later on. (Shown in **Figure 23**)

17. Let's prepare the exhaust pipe for installation. Begin by attaching the new flanges and snap rings that came with the pipes onto the inlets, and insert the small P-clamp to the right place, between these two 12mm-O2 sensor ports. (Shown in **Figure 24/25**) The P-leg should face the bracket side for the next connecting.

Note: Be very careful while inserting retaining rings into headers, wear some type of safety glasses for the retaining rings may spring back and cause injuries. The slot on the flange for the snap ring should be faced to the engine port side.

18. Prior to installing the pipe, it's essential to check that the gasket at the engine port is in good condition. If it appears worn or damaged, you'll need to replace it with one of the new gaskets that came with the pipes.

Note: Be very careful while removing or inserting the gasket. Do not damage the sphere engine port.

19. Excellent. The next step is to thread the O2 sensor wires through the bung on the exhaust pipe. The gray wire should be connected to the front engine port, while the black one should be connected to the rear engine port. There are four O2 sensor ports on the header, up-2-18mm & down-2-12mm. So please choose the right one to connect according to your sensor wire. For the 18mm one, you need an 8mm (5/16") hex Allen wrench with a ball end to remove the bung. After inserting the wire into the bung, use a 22mm (7/8") wrench to securely tighten it down.

Note: O2 sensor I.D.-12mm, need to use 6mm(7/32") hex Allen wrench to remove bung, and a 14mm (9/16") wrench to tighten. If you do not want to reconnect the O2 sensor wire, then please leave the sensor plug in.

20. Once you've connected the O2 sensor wires to the exhaust pipes, take the exhaust body in both hands and hold them aligned to both engine ports. You should be able to hold the body with one hand, while using the other hand to finger tighten the bolts or nuts. If you find that you are unable to hold it with one hand, you may need to seek assistance from someone else during this step.

Note: If you have torque cones, please install them into the head pipe inlet before align them to the engine port. They are very helpful on keeping the end torque & gain better performance. Our torque cone is special. You can not find on other place. (Torque cones sold separately.)

21. We can now begin proceeding with the exhaust pipe assembly. Hold up the exhaust body and position both inlets near the engine ports. Ensure proper alignment and use your fingers to tighten the nuts onto the flange studs, but do not fully tighten them yet. Also, make sure that the bracket we installed earlier is properly aligned with the back bracket of the exhaust body. Keep the triangle formed by the front engine port, the rear engine port, and the bracket aligned correctly. (Shown in **Figure 26/27/28**)

Note: Please use the nuts coming with the pipes.

22. Use the Carriage Bolt and nut for hanging the exhaust body to the bracket. (Shown in **Figure 28**) Do not use a socket to tighten them at this time for later alignment with the crossover pipe and mufflers. (Shown in **Figure 29/30**)

23. Once the previous steps have been completed, install the crossover pipe with the big P-clamp on. (Shown in **Figure 31/32**) Please make sure to install the P-clamp right. P-legs face up, and P-head faces to the bike front. You might need to break P-legs apart more to allow the pipe in. Please be careful not to scratch the surface of the pipe. Once the crossover pipe in, then use a 1/4-20*3/4 bolt and a 1/4-20 nut to pull the P-shape back to normal and easier for later installing. (Shown in **Figure 33**)

24. Then connect the crossover pipe to the front engine port header with a 48-51mm clamp. And hang the crossover pipe underneath the bike with two 1/4-20 bolts. (Shown in **Figure 34**)

25. Now, you can see the crossover pipe from the left side of the bike. Before tightening it down to the end, we need to check the consistent alignment with the muffler. Insert the stock muffler back into the header, and hang it back with stock muffler hangers. (Shown in **Figure 35/36**)

26. Once completed, the right-side muffler can be installed back. Align the muffler with the rear engine port header, and hang it back to the muffler bracket. Then fix them with the stock clamp. (Shown in **Figure 37/38**)

27. Before installing the heat shield, make sure to check and adjust the gap between the header pipes or the horizontal level of the mufflers. After all the adjustments have been made, we can tighten all the screws & bolts way down to the end. Additionally, we already marked the heat shield positions on the head pipes and crossover pipe, then you can tell where each of the hose clamps goes through. Install the heat shield back to the exhaust. (Shown in **Figure 39/40**)

28. Awesome. We are almost there. Now we need to install the right floorboard for the rider back. 1 Bolt of **3/8-16*2"**, 1 Bolt of **3/8-16*3-1/2"**, with 2 of **M10 Flat Washers**, and 2 **Aluminum Spacers of length-19* I.D.-10 * O.D.-16MM**.

(Shown in **Figure 41/42/43**)

29. Now, plug the O2 sensor wires to the bike. Gray to Gray, Black to Black.

30. Before starting your bike, please check all the bolts, nuts, clamps, and screws, including the heat shields are all tighten down. No rattling sound or other issue.

(Shown in **Figure 44**)

31. Finally, be sure to wipe all fingerprints or oil stain off after installation, before start the engine.

Note: If you leave a fingerprint to it, the chrome may discolor when it heats up!

Figure 1



Figure 2



Figure 3



Figure 4

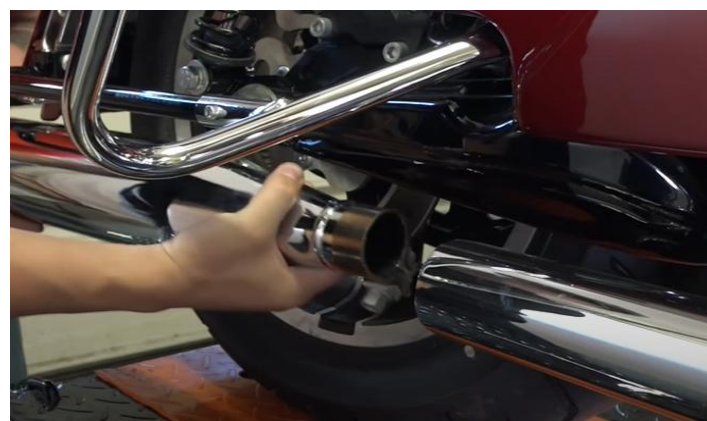

Figure 5

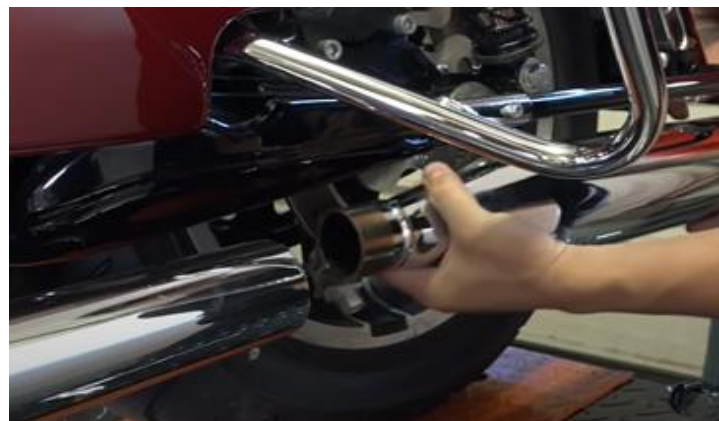

Figure 6



Figure 7



Figure 9



Figure 11

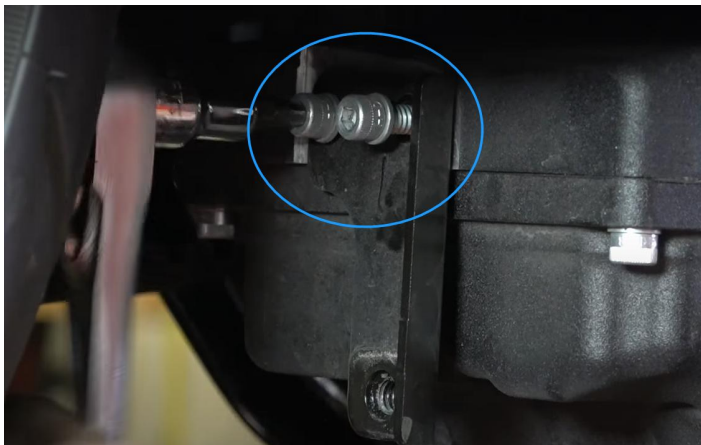

Figure 13



Figure 8



Figure 10



Figure 12



Figure 14



Figure 15



Figure 16



Figure 17



Figure 18

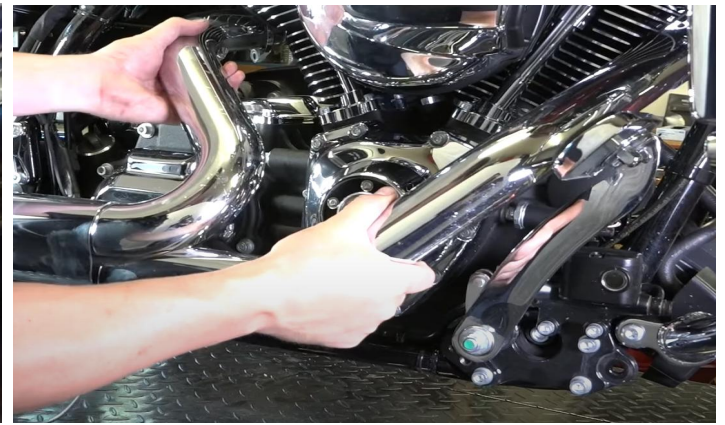

Figure 19



Figure 20

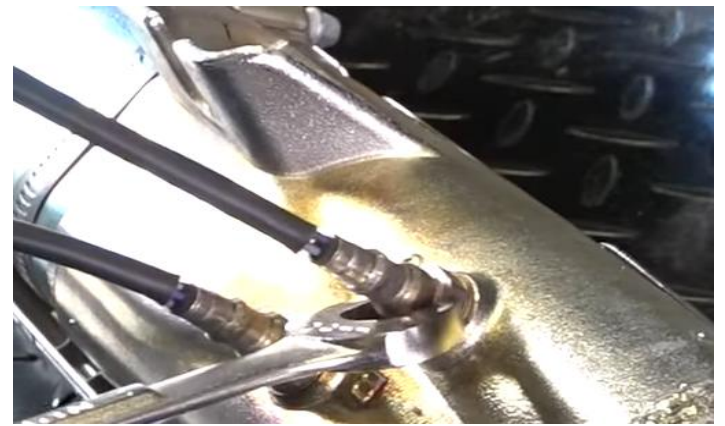

Figure 21

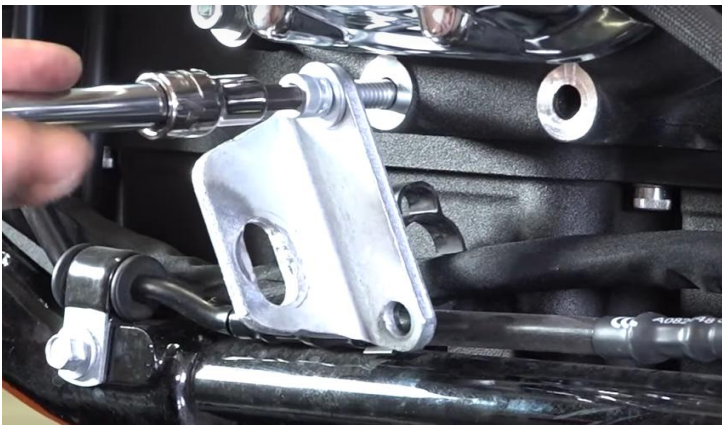

Figure 22



Figure 23



Figure 24



Figure 25



Figure 26



Figure 27



Figure 28



Figure 29

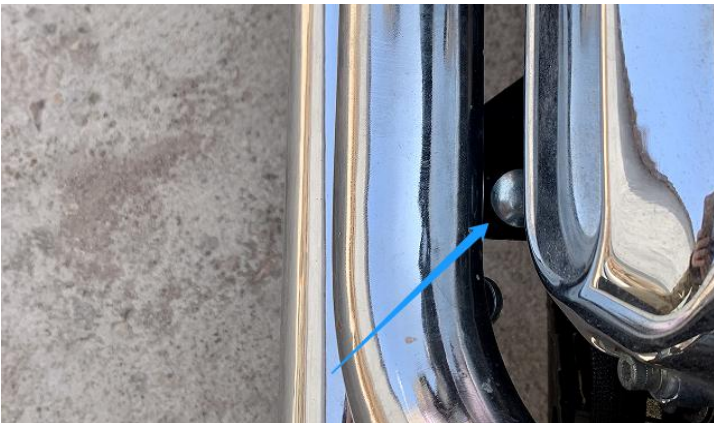

Figure 30



Figure 31



Figure 32



Figure 33



Figure 34



Figure 35



Figure 36



Figure 37



Figure 38



Figure 39

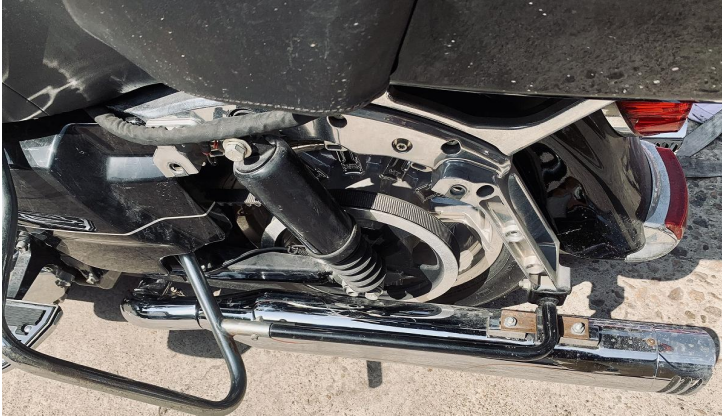

Figure 40



Figure 41



Figure 42

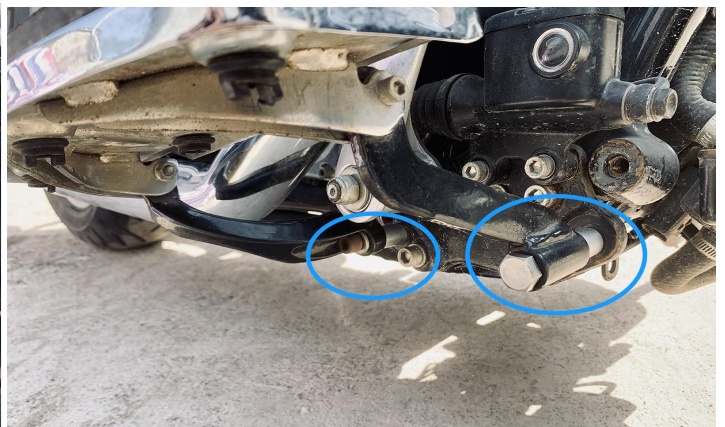

Figure 43



Figure 44



- 1. Please re-tuning your motorcycle immediately with Dyna Tuning Map after changing head pipes.**
- 2. Be sure to tighten all hardware before starting your engine. Re-tighten after the first 100 miles.**
- 3. We use the headers waiting for being re-chroming to show the installation steps. So please ignore we put them directly on the ground. Please put yours on a soft blanket or cushion to avoid being scratched.**

Discoloration: DOES NOT WARRANTY ANY CHROME EXHAUST PRODUCTS AGAINST DISCOLORATION!

Discoloration is not a defect in chrome. All chrome exhaust systems will turn color. Chrome discoloration is a result of heat. The more heat the chrome is exposed to, the quicker and more severe the discoloration will be.

Tuning: It is strongly recommended by . Better flowing, less restrictive exhaust will require

more intake, so please consider upgrading your air cleaner along with your fuel-management system.

Working with high-flow intake, Fuel Management system, and correct profession re-mapping, the bike would gain a more better performance.

C.A.R.B.: California does not allow the use of aftermarket exhaust systems that remove original equipment catalysts, (except for racing use only) unless the Air Resources Board has issued an Executive Order for that system.

Returns: When you want to return, please contact us in 72 hours after received the product so we can help you out immediately. We only accept return in 30 days after your order. International Return is not acceptable. For return shipping cost to our warehouse, If the product have quality or shipping damage issue, We will send you shipping label or pay the cost after you send out. If you don't like the product or buy by mistake, Buyer should stand this shipping cost.

Warranty: products are warranted for one year against defects in material and workmanship.

This warranty does not cover chrome discoloration or rust. Also will not warranty any abused, misused, improperly installed or modified system.

Wearing a helmet while riding is always recommended.

Please never go for a ride while under the influence of alcohol and/or drugs.

Enjoy the new voice and the fresh look of your motorcycle and ride safe.