



# HITCH RACK

INSTALLATION GUIDE



## THE APEX OF SECURITY

Load. Lock. Go. Whether it's a gnarly off-road trek to your deer camp, daily ride to a worksite or smooth cruise to your next game-day tailgate, you don't have to worry about your cooler being secure or vulnerable to theft. Follow these easy step-by-step instructions to install this bad boy, then hit the road with confidence.

### READ BEFORE ASSEMBLING

---

Please carefully read the guidelines to the installation and use of the Hitch Rack before beginning use. All steps of the installation process are solely your responsibility.

The manufacturer's warranty is exclusively limited to the repair or replacement of a defective Hitch Rack. Damage to your vehicle, its contents or to any person or property is excluded. Damage or failure due to improper installation, use or general wear is not covered by this warranty.

Because of the size and structural difference between vehicles, we rely upon your discretion in attaching the Hitch Rack to your vehicle's receiver hitch. Also, please check local laws regarding obstruction of your vehicle's license plate before using your Apex Hitch Rack on public roadways.

Prior to each use, confirm all components are properly attached, tightened and locked. It is also important to check for any signs of wear, corrosion or fatigue. If any of these issues are present, do not use the product. When traveling, periodically inspect the hardware to confirm it is fastened securely.

Remove the Hitch Rack when cooler is not in use.

### WARRANTY INFORMATION

---

A 2-year limited warranty is included on parts (except for powder coating) that fail due to a manufacturing defect. Please visit [apexcoolers.com](http://apexcoolers.com) for more information.

## PARTS LIST

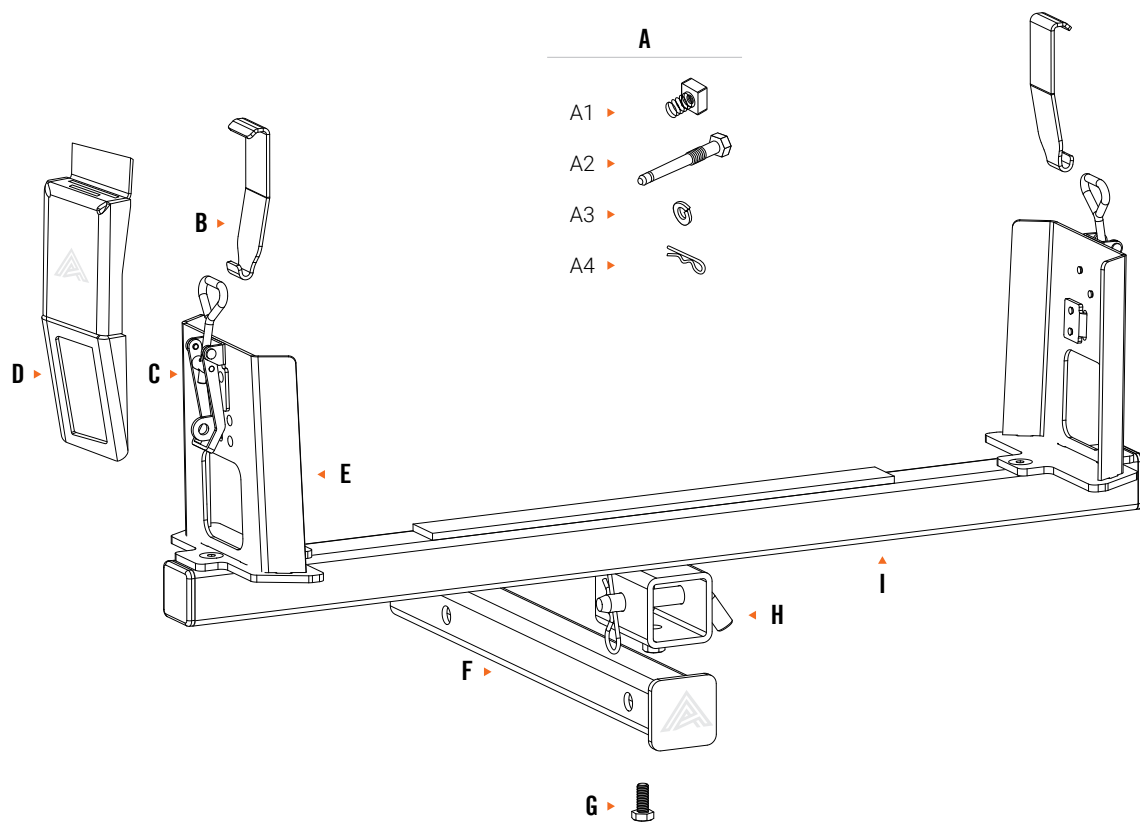

### A ▶ SILENT HITCH PIN®

- A1 SPRING NUT
- A2 SILENT HITCH PIN
- A3 SPLIT WASHER
- A4 METAL CLIP

### B ▶ COOLER STRAP (2)

### C ▶ LATCH

### D ▶ LATCH COVER

### E ▶ WINGS

### F ▶ RECEIVER TUBE

### G ▶ TENSION SCREW AND LOCK NUT

### H ▶ ASSEMBLY HITCH PIN AND COTTER PIN

### I ▶ CROSS TUBE

### ADDITIONAL TOOLS NOT INCLUDED

*Recommended*

- 5/8" wrench
- 9/16" wrench
- 7/8" wrench
- Lock with a shackle diameter of 3/8" or less

## ASSEMBLY OF HITCH RACK

---

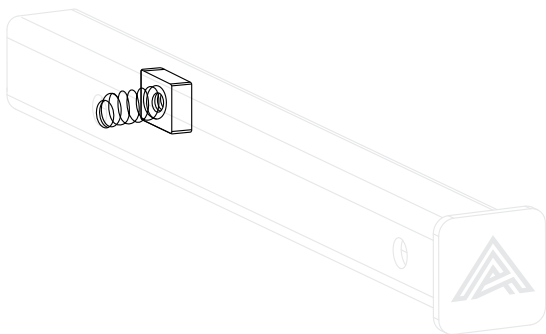

### STEP 1

Insert the Spring Nut of the Silent Hitch Pin® into the Receiver Tube.

*A separate instruction manual is included for this step, located in the Silent Hitch Pin® product bag.*

## ASSEMBLY OF HITCH RACK

---

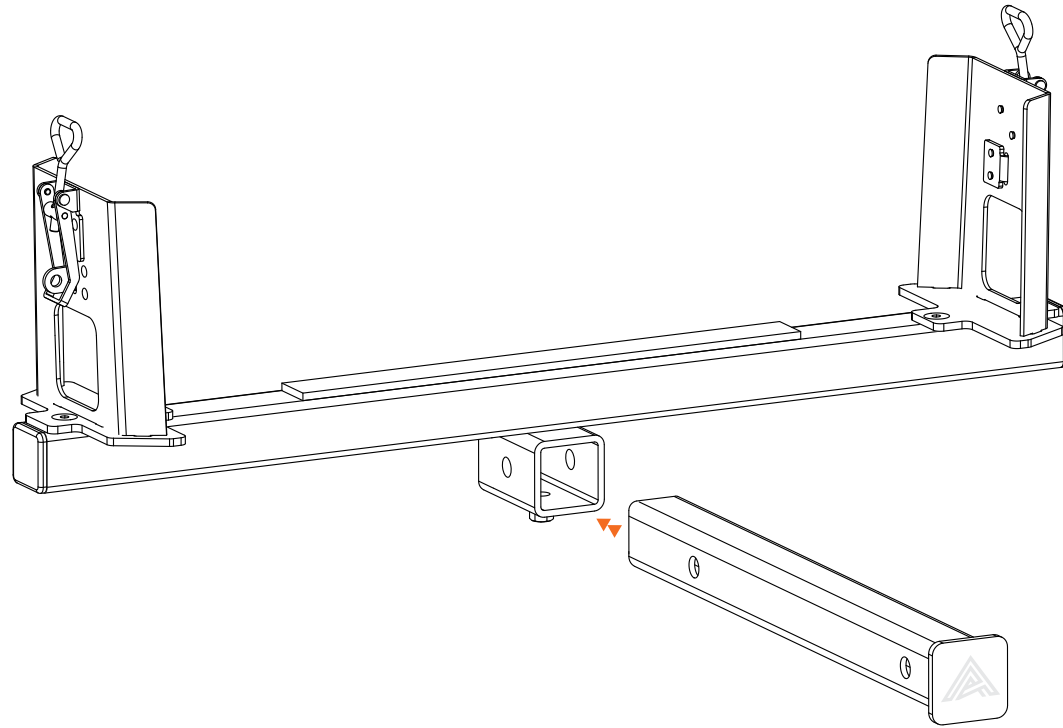

### STEP 2

Slide the Receiver Tube through the collar of the Cross Tube.

## ASSEMBLY OF HITCH RACK

---

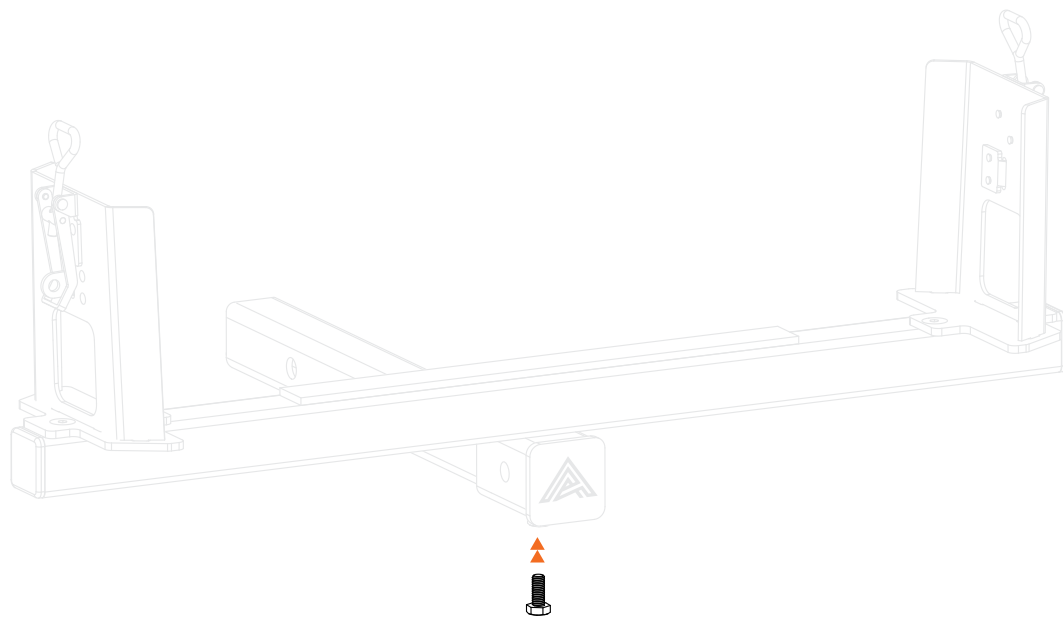

### STEP 3

Tighten the Tension Screw and Lock Nut into the collar of both the Receiver Tube and the Cross Tube. This piece reduces movement between the Receiver Tube and the Cross Tube during cooler transport.

1. First, hand tighten the screw.
2. Then use wrench to securely tighten both the Tension Screw and the Lock Nut until tight – this should remove almost all movement between the Cross Tube and the Receiver Tube.

## ASSEMBLY OF HITCH RACK

---

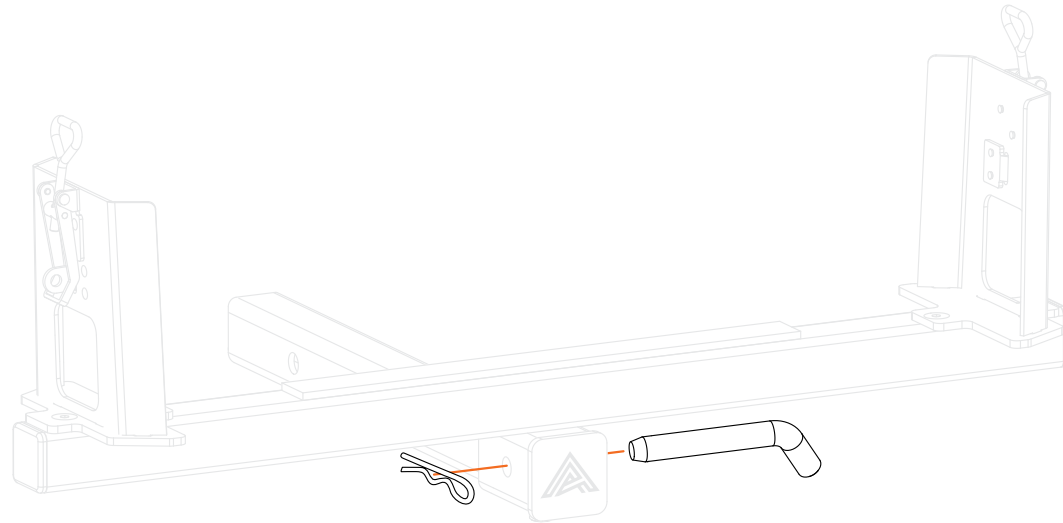

### STEP 4

Slide the Assembly Hitch Pin into the round opening of the collar of the Cross Tube and the Receiver Tube.

Clip the Cotter Pin onto the left arm of the Assembly Hitch Pin.

## ATTACHMENT TO RECEIVER HITCH

---

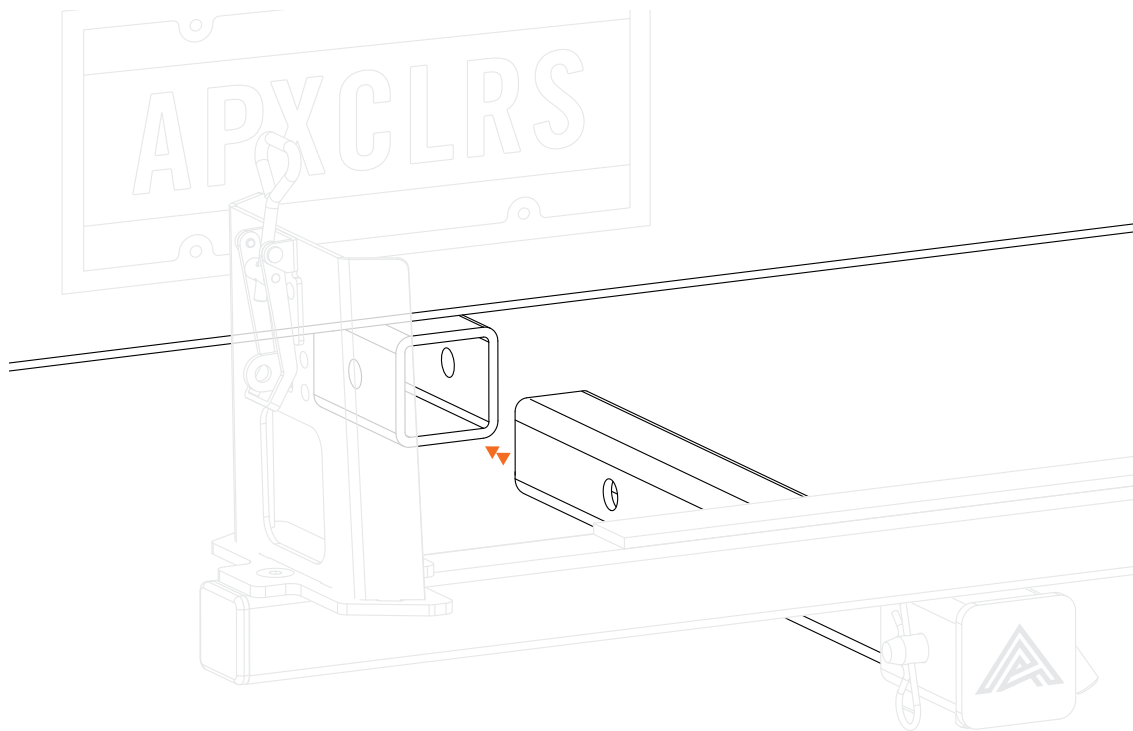

### STEP 5

Slide the end of the Receiver Tube into your vehicle's Receiver Hitch. The hitch pin holes on the Receiver Tube should align with the hitch pin holes on the Receiver Hitch.



## ATTACHMENT TO RECEIVER HITCH

---

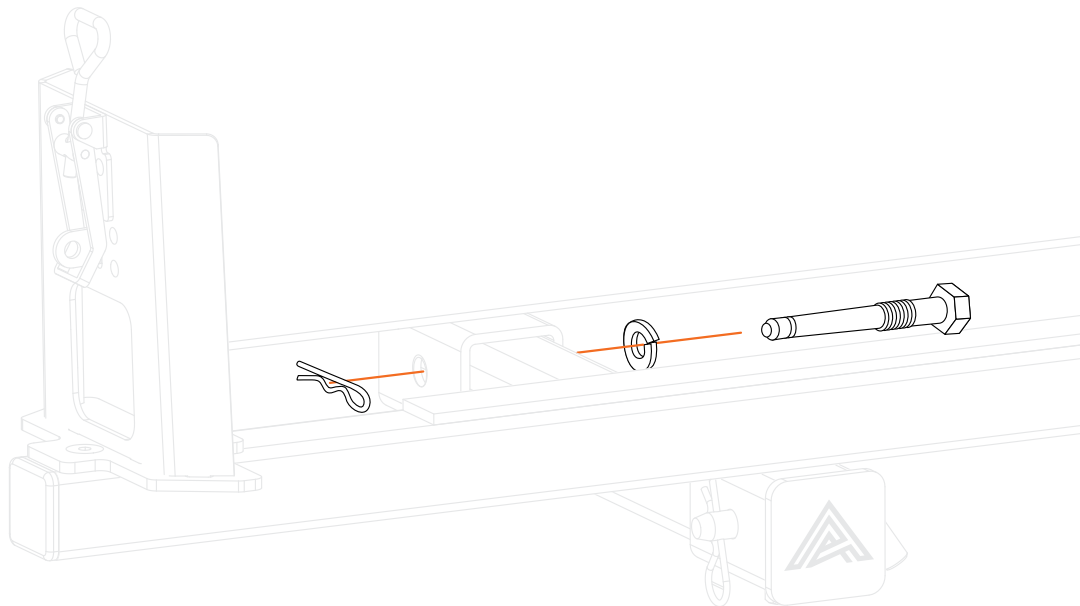

### STEP 6

Insert the Silent Hitch Pin® into the receiver hitch and the Receiver Tube to reduce rattle.

1. First, hand tighten the pin.
2. Use the  $\frac{7}{8}$ " wrench to tighten both the screw and the nut until tight.
3. Clip the Cotter Pin onto the left arm of the Silent Hitch Pin.®

## ATTACHMENT TO RECEIVER HITCH

---

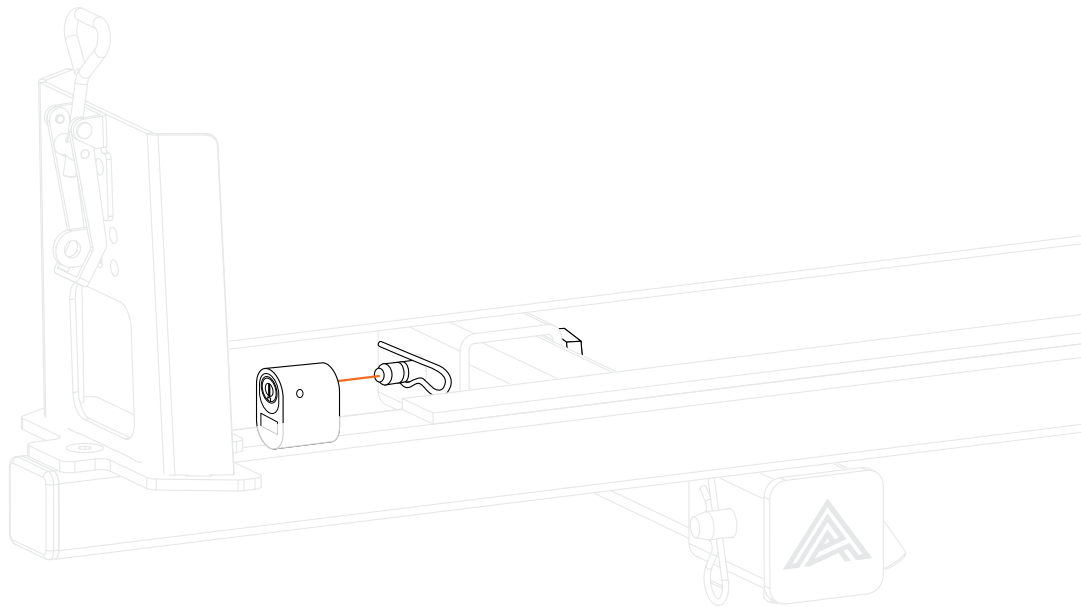

### STEP 7

To further secure the Hitch Rack to the vehicle, install a lock on the Silent Hitch Pin.®

*A lock is available for purchase at [apexcoolers.com/extras](http://apexcoolers.com/extras)*

## SECURE THE COOLER

---

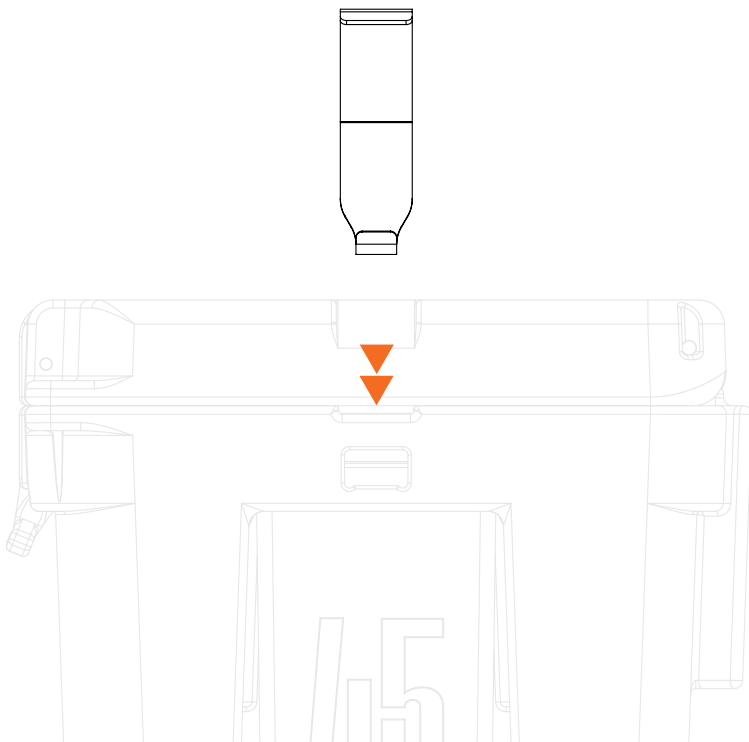

### STEP 8

Slide the Cooler Straps through the slots on either side of the base of the cooler.

You may have to adjust the rope of the cooler handles out of the way to install the Cooler Straps. Due to the tight level of manufacturing tolerance, you might have to exert slight force to insert into the slots.

## SECURE THE COOLER

---

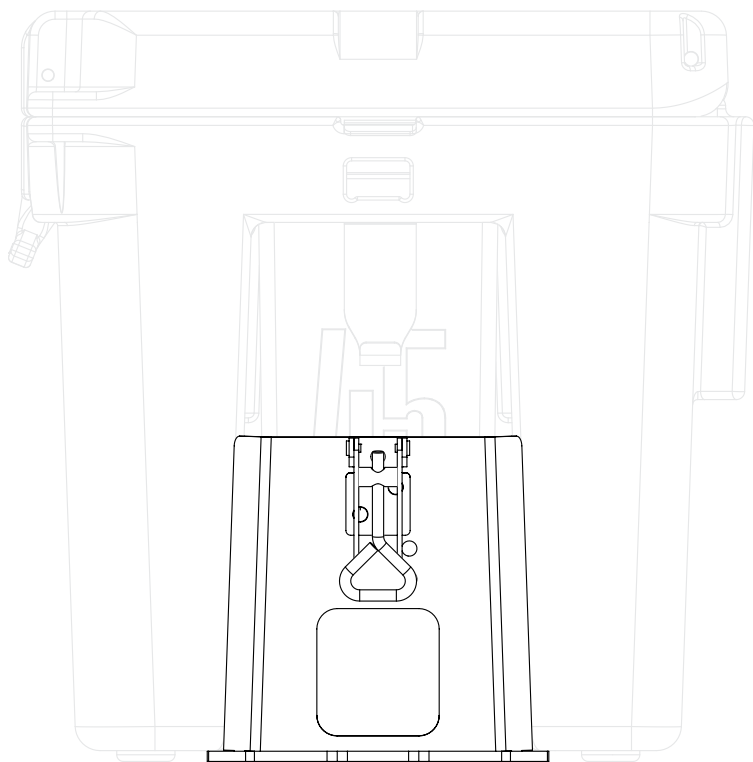

### STEP 9

Lift your A45 or A75 APEX Cooler above the Hitch Rack and slide the Wings into the grooved cooler sides.

## SECURE THE COOLER

---

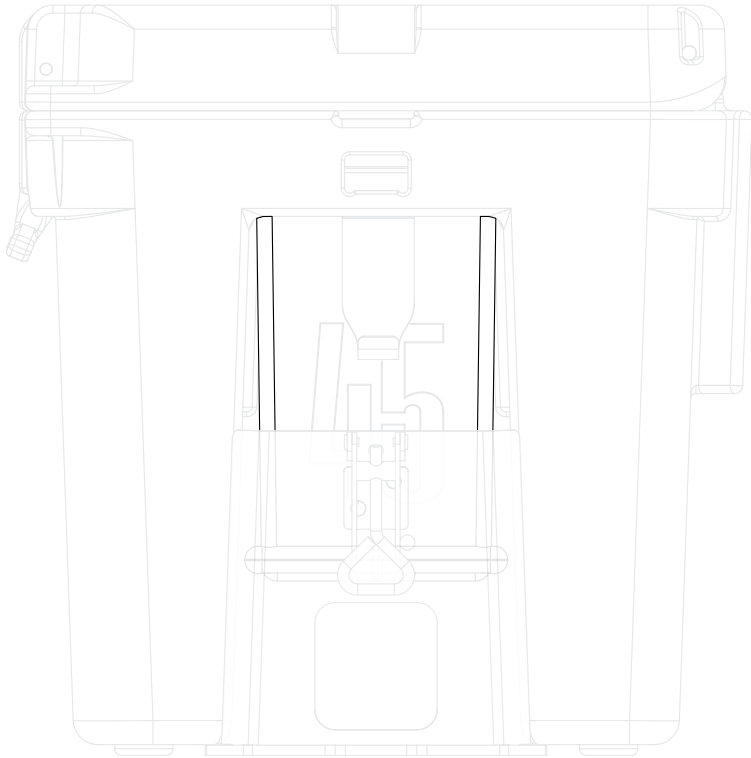

### STEP 10

Tuck the cooler handles behind the Wings to keep them secure during transport.

## SECURE THE COOLER

---

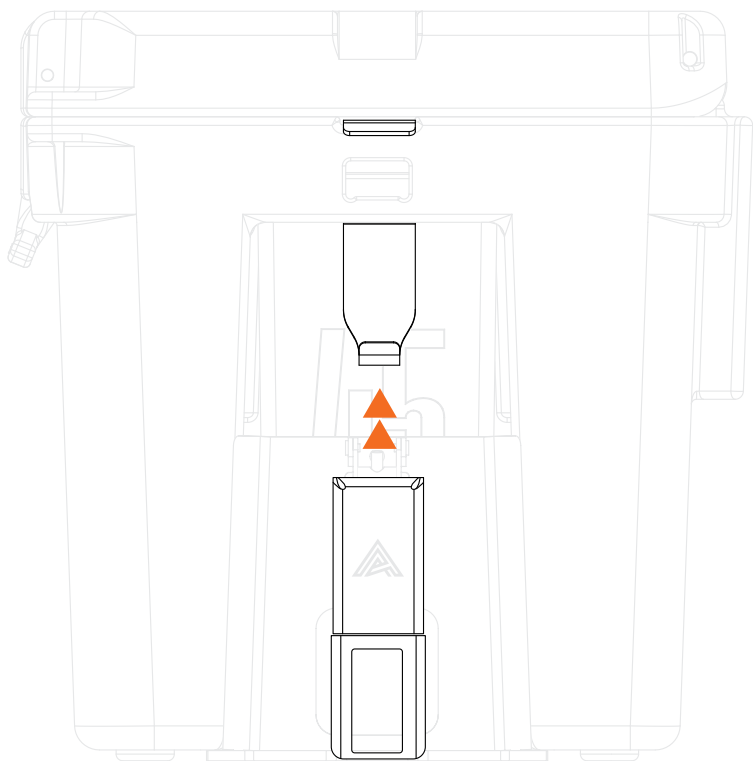

### STEP 11

To further secure the cooler, place the Latch Cover over one of the latches. Insert the bottom of the Cooler Strap into the opening at the top of the Latch Cover.

## SECURE THE COOLER

---

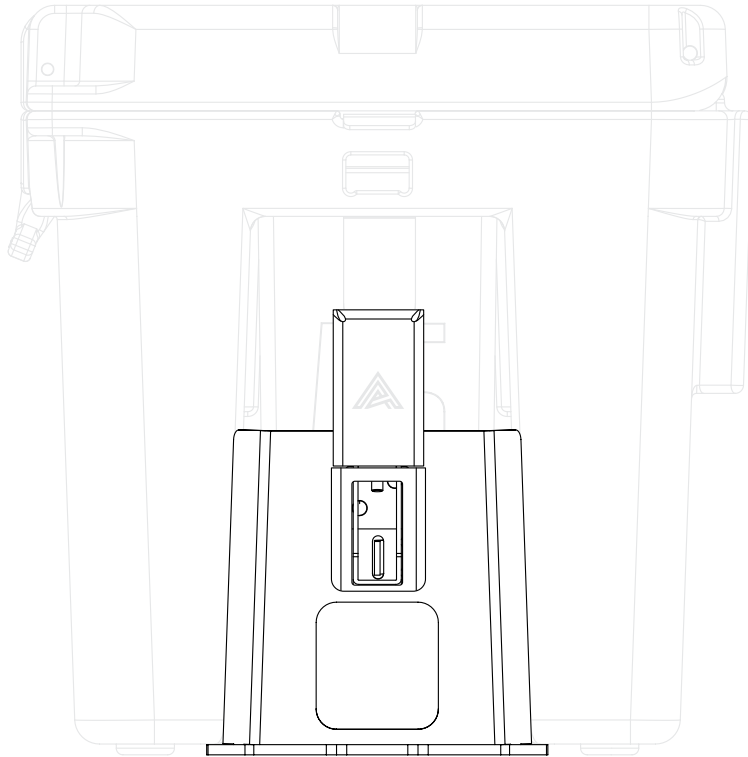

### STEP 12

Pull the Latch up and hook it to the bottom of the Cooler Strap on either side of the cooler. Then, pull the Latch down on both sides of the cooler to secure the latches into place. The Latch Lever should rest on top of Latch Cover when snapped into place.

*Note that the latches are adjustable and can be tightened or loosened as needed by twisting the threaded lever. If you overtighten the latch, doing so will keep it from closing.*

*You may also padlock both sides of your Cooler with or without a Latch Cover. If an additional security step is necessary, you may purchase a second Latch Cover (sold separately).*

## SECURE THE COOLER

---

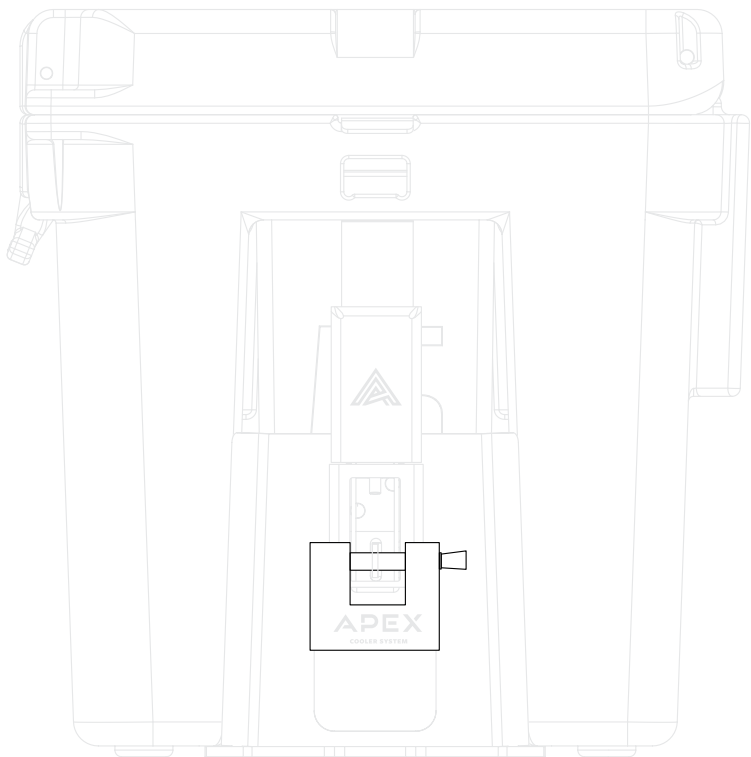

### STEP 13

To fully secure your cooler into place, insert locks through each padlock hole near the lever. Note that the padlock holes can take up to a  $\frac{3}{8}$ " shackle diameter lock.

*Note that the padlock holes can take up to a  $\frac{3}{8}$  inch shackle diameter lock.*





[APEXCOOLERS.COM](http://APEXCOOLERS.COM)