

rpb C40 CLIMATE CONTROL

INSTRUCTION MANUAL



CONTENTS

■ INTRODUCTION	4
■ RESPIRATORY COMPONENT CONCEPT	5
■ WARNINGS	6
■ RESPIRATOR OPERATION	8
■ SPECIAL OR CRITICAL USERS INSTRUCTIONS	
- BREATHING AIR PRESSURE TABLE	9
■ RESPIRATOR ASSEMBLY & SETUP	10
■ INSPECTION CLEANING & STORAGE	12
■ FLOW AND TEMPERATURE CHART	15
■ PARTS LIST	15
■ APPENDIX A	17

**Read all instructions and warnings before using this product.
Keep this manual for future reference.**

RPB® Safety Global Headquarters

2807 Samoset Rd, Royal Oak, MI 48073, USA.

T: 1-866-494-4599 F: 1-866-494-4509 E: sales.us@rpbsafety.com rpbsafety.com

RPB® Safety Asia Pacific Headquarters

652 Halswell Junction Road, Hornby South 8042 New Zealand.

T: +64-3-357-1761 F: +64-3-357-1763 E: sales.nz@rpbsafety.com rpbsafety.com

RPB®, Advancing Your Safety®, Nova®, Nova 3®, Radex®, Zytec®, Z-LINK® and T-LINK® are registered trademarks of RPB® Safety LLC

For technical assistance contact our Customer Service Department at 1-866-494-4599 or email: customerservice@rpbsafety.com

FORM #: 7.20.522

REV: 4

C40™ CLIMATE CONTROL

INTRODUCTION

The RPB® C40™ Climate Control Device is NIOSH approved to supply a continuous flow of warm or cold air to any one of the following respirator assemblies:

Astro® - Blasting Respirator
Nova 2000® - Blasting Respirator
Nova 3® - Blasting Respirator
Z-Link® - Multipurpose Respirator
T-Link® - Multipurpose Respirator

The RPB® C40™ Climate Control Device is designed for use in many different industries such as Blasting, Painting, Grinding and other such areas where you would like to adjust the air temperature in the respirator hood.

The RPB® C40™ Climate Control Device has been designed for use in atmospheres that are **NOT IMMEDIATELY DANGEROUS TO LIFE OR HEALTH (IDLH)**.

Before occupational use of this respirator, a written respiratory protection program must be implemented meeting all the local government requirements. In the United States, employers must comply with OSHA 29 CFR 1910.134 which includes medical evaluation, training, and fit testing.

WARRANTY

All RPB® products are covered by a manufactures warranty of 3 months. The manufacturer warranty covers defects in material, workmanship and does not cover damage caused by misuse or abuse. RPB®'s only obligation and your exclusive remedy shall be to repair, replace or refund the purchase price of such parts or products upon the presentation of proof of purchase. Maximum liability is in no case to exceed the value of the RPB® Product involved.

RESPIRATORY COMPONENT CONCEPT

An RPB® Respirator consists of 3 main components:

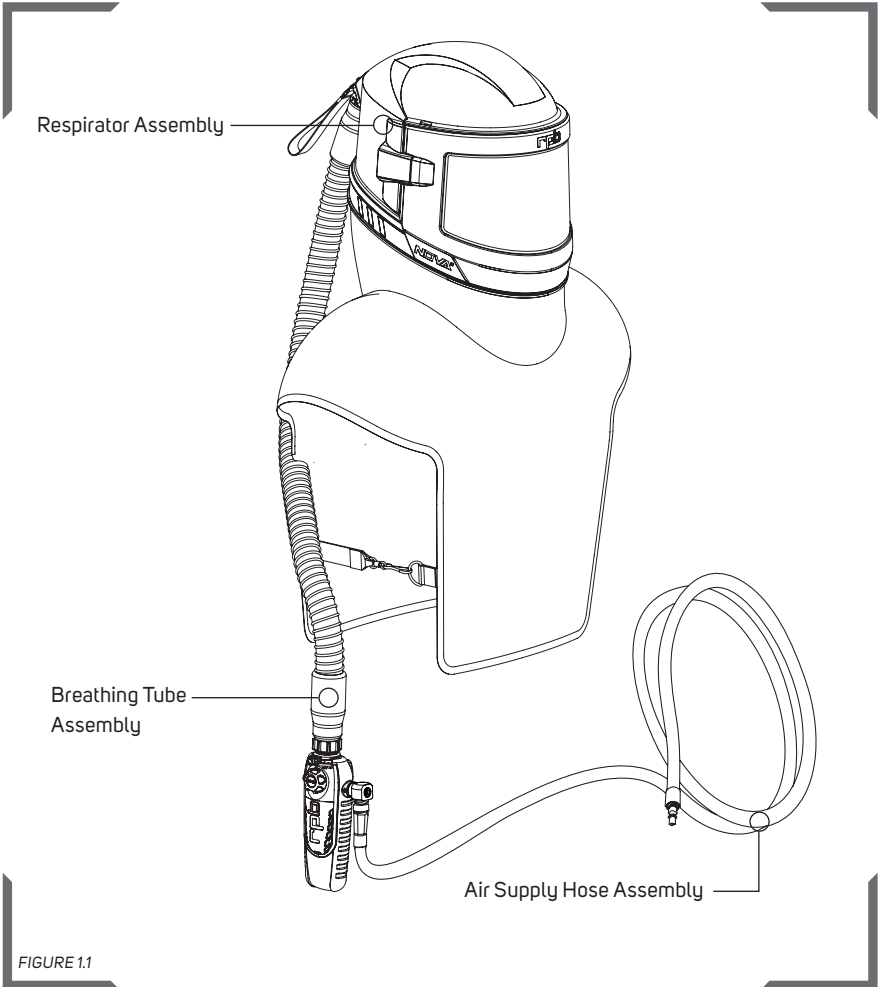

FIGURE 1.1

!WARNING! Failure to use genuine parts and components that are part of the NIOSH approved respirator assembly will void the approval of the entire respirator assembly.

RPB® C40™ CLIMATE CONTROL

!WARNINGS!

1. Do not use this C40™ Climate Control Device until you have been trained in the respirators use, maintenance and limitations by a qualified individual (appointed by your employer) who has extensive knowledge of the RPB® C40™ Climate Control Device.
2. Before using an RPB® Respirator ensure your employer has determined that airborne contaminant concentrations do not exceed those allowed by applicable OSHA, EPA or NIOSH regulations and recommendations for continuous-flow supplied air respirators. Federal law requires that the employer measures and monitors airborne contaminant levels in the work area.
3. DO NOT WEAR an RPB® Respirator if any of the following conditions exist: - Atmosphere is immediately dangerous to life or health. - You CAN NOT escape without the aid of the respirator. - Atmosphere contains less than 19.5% Oxygen. - Work area is poorly ventilated. - Contaminants are in excess of regulations or recommendations.
4. Do not modify or alter this Device. Use only parts and components that are part of a NIOSH approved respirator assembly. The use of non RPB® parts voids the NIOSH approval of an entire respirator assembly.
5. Inspect all components daily for signs of damage or wear that may reduce the level of protection originally provided.
6. Only use this device in areas that are in accordance with the specific respirator it is attached to, i.e. Nova 3® Blasting Respirator.
7. Do not wear an RPB® Respirator until you have passed a complete physical exam maybe including a lung X-ray conducted by qualified medical personnel.
8. Improper use of an RPB® Respirator may cause injury or death. Improper use may also cause life threatening delayed lung disease such as silicosis, pneumoconiosis or asbestosis.
9. An RPB® Respirator, when properly fitted and used, significantly reduces but does not completely eliminate the breathing of contaminants by the respirator wearer.
10. Be certain your employer has determined that the breathing air source provides at least Grade D breathable air. An RPB® Respirator must be supplied with clean breathable air at all times.
11. Do not connect an RPB® Respirator's air supply hose to nitrogen, toxic gases, inert gases or other non-breathable non Grade D air source. Check the air source before using an RPB® Respirator. Failure to connect the supply hose to the proper air source could result in serious injury or death.
12. DO NOT use an RPB® Respirator in poorly ventilated areas or confined spaces unless the area is well ventilated and that the contaminant concentrations are below those recommended for this respirator. Follow all procedures for confined space entry, operation and exit as defined in applicable regulations and standards including 29 CFR 1910.146.
13. Always fully read the instruction manual of the appropriate an RPB® Respirator that you are intending to attach this C40™ Climate Control Device to.
14. LEAVE WORK AREA IMMEDIATELY IF: - Any respirator component becomes damaged. - Airflow stops or slows down.

!WARNINGS! CONTINUED

- Breathing becomes difficult. - You become dizzy, nauseous, too hot, too cold, or ill. - Vision is impaired.
- 15. The inner components of this C40 Climate Control Device will become very hot, take care when removing the parts so that you do not get burnt. Allow sufficient time for the device to cool down before dismantling the device.
- 16. Do not ingest ice that is formed on the C40™ Climate Control Device.
- 17. This C40™ Climate Control Device cannot be used with an Ambient Low Pressure Air Pump.

AIR FILTRATION & CARBON MONOXIDE MONITORING

It is an OSHA requirement that all RPB® Supplied Air Respirators be supplied with CGA G-7.1 Grade D air. To achieve this, RPB® recommends using the Radex™ Airline Filter (04-900) and a GX4 Gas Monitor (08-400). Further information is available by contacting RPB® at 1-866-494-1599 or from your nearest authorized RPB® distributor.

NIOSH – CAUTIONS & LIMITATIONS

- A)** Not for use in atmospheres containing less than 19.5 percent oxygen.
- B)** Not for use in atmospheres immediately dangerous to life or health.
- C)** Do not exceed maximum use concentrations established by regulatory standards
- D)** Air-line respirators can be used only when the respirators are supplied with respirable air meeting the requirements of CGA G-7.1 Grade D or higher quality.
- E)** Use only the pressure ranges and hose lengths specified in the user's instructions
- J)** Failure to properly use and maintain this product could result in injury or death.
- M)** All approved respirators shall be selected, fitted, used and maintained in accordance with MSHA, OSHA, and other applicable regulations.
- N)** Never substitute, modify, add or omit parts. Use only exact replacement parts in the configuration as specified by the manufacturer.
- O)** Refer to user's instructions, and/or maintenance manuals for information on use and maintenance of these respirators.
- S)** Special or critical user's instructions and/or specific limitations apply. Refer to user Instructions on page 8 (breathing air pressure table) before donning.

RPB® C40™ CLIMATE CONTROL

RESPIRATOR OPERATION

AIR QUALITY

A Supplied Air Respirator must be supplied with clean breathable air at all times. Breathable air must at least meet the requirements for Type 1 gaseous air described in the Compressed Gas Association Commodity Specifications G.7.1 (Grade D or higher) and as specified by Federal Law 42 CFR 84, subpart J.84.141(b) and 29 CFR 1910.134 (i) the RPB® C40™ Climate Control Device does not purify air or filter contaminants.

AIR SOURCE

Locate the air source in a clean air environment; always use a filter on the inlet of your air source. Do not park vehicles beside your air inlet as this will cause carbon monoxide to be drawn into your air supply. Always use suitable after coolers/dryers with filters and carbon monoxide alarms to ensure clean breathable air is supplied at all times. The air should be regularly sampled to ensure that it meets Grade D requirements.

BREATHING AIR SUPPLY HOSES & FITTINGS

RPB® air supply hoses and fittings that are part of the NIOSH approved respirator assembly must be used between the point of attachment and the respirator breathing air connection at the wearer's belt. The hose sections must be within the correct length and the amount of sections must be within the number specified in the breathing air pressure table on Page 9.

BREATHING AIR PRESSURE

The air pressure must be continually monitored at the point of attachment to confirm it meets Grade D requirements. Air pressure must be read from a reliable pressure gauge whilst the respirator has air flowing through it.

!WARNING!

Failure to supply the minimum required air pressure (for the length of air supply hose) at the point of attachment could result in contaminants being inhaled. This risk is due to the pressure in the helmet becoming negative when the peak inhalation flow (at high work rates) exceeds that of the supplied air.

The RPB® C40™ Climate Control Device Breathing Air Pressure table on page 8 defines the air pressure ranges needed to provide the respirator with a volume of air which falls in the required range of 6-15cfm (170-425 slpm).

SPECIAL OR CRITICAL USERS INSTRUCTIONS

BREATHING AIR PRESSURE TABLE

This table lists air pressure ranges needed to provide the RPB® Supplied Air Respirators with the volume of air that falls within the required range of 6-15cfm or 170-425 slpm according to U.S government regulations

Make sure you understand the Breathing Air Pressure table before using this respirator.

- Determine your air source (column 1)
- Identify your RPB® Respirator assembly setup (column 2)
- Confirm the part number of the air supply hose you are using (column 3)
- Check your RPB® Air Supply Hose is within the correct length (column 4)
- Set the air pressure at the point of attachment within the range specified (column 6) for your breathing tube assembly, hose length and number of hose sections (column 5).
- Make sure air is flowing through your respirator when setting the air pressure.

1. AIR SOURCE	2. BREATHING TUBE ASSEMBLY AND FLOW CONTROL DEVICES	3. AIR SUPPLY HOSE	4. SUPPLY HOSE LENGTH (FT)	5. MAX NUMBER OF SECTIONS	6. PRESSURE RANGE (PSIG AIR)
Portable or Stationary Compressor	Astro or Nova 2000 NV2021 03-500	NV2028 (26ft) NV2029 (50ft) NV2027 (100ft)	25	1	50 - 80
			50	1	55 - 85
			100	2	60 - 95
			150	3	65 - 95
			200	4	70 - 100
			250	5	75 - 100
300	6	85 - 100			
Portable or Stationary Compressor	Nova 3 NV2021B 03-500	NV2028 (26ft) NV2029 (50ft) NV2027 (100ft) 04-352-25-RZ (25ft) 04-352-50-RZ (50ft) 04-352-100-RZ (100ft)	25	1	50 - 80
			50	1	55 - 85
			100	2	60 - 95
			150	3	65 - 95
			200	4	70 - 100
			250	5	75 - 100
300	6	85 - 100			
Portable or Stationary Compressor	Z-Link or T-Link 04-830 03-500	NV2028 (26ft) NV2029 (50ft) NV2027 (100ft)	25	1	50 - 80
			50	1	55 - 85
			100	2	60 - 95
			150	3	65 - 95
			200	4	70 - 100
			250	5	75 - 100
300	6	85 - 100			

RPB® C40™ CLIMATE CONTROL

RESPIRATOR ASSEMBLY & SETUP

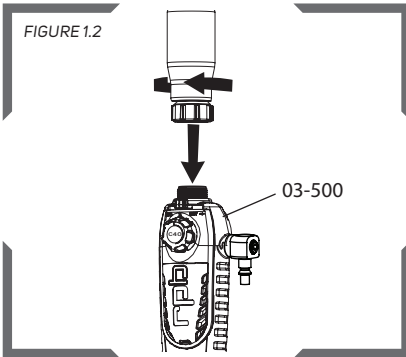

Attach the RPB® C40™ Climate Control Device. Thread on the loose running nut of the Breathing Tube on to the C40™ Climate Control Device (03-500). Screw the running nut in a clockwise direction until tight.

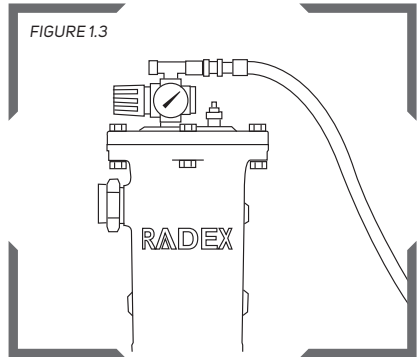

CONNECT AIR SUPPLY HOSE

Adjust the air pressure at the point of attachment according to the Breathing Air Pressure Table on page 9.

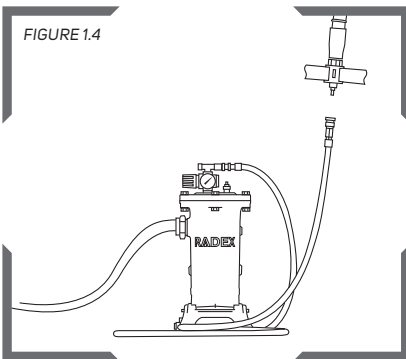

ADJUST AIR PRESSURE

Connect a RPB® Air Supply Hose insuring the maximum sections and lengths are within the specifications on page 9.

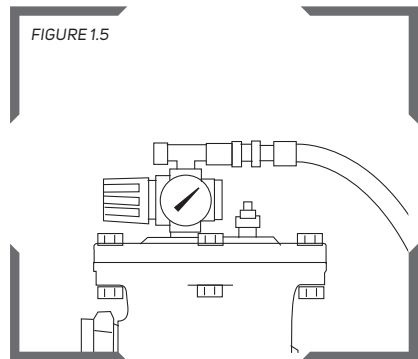

CHECK AIR PRESSURE

Re-check the air pressure at the point of attachment and adjust it if necessary. Ensure you are comfortable with the flow of air inside the respirator.

RESPIRATOR ASSEMBLY & SETUP CONTINUED

ADJUSTING THE FLOW RATE

Air flowing into the respirator is controlled by the C40™ (03-500) by turning the Flow Knob (03-524) as shown in Figure 1.6. Note: With the pressure set according to the Breathing Air Pressure Table the flow rate of air through the respirator should always exceed the minimum of 170 slpm.

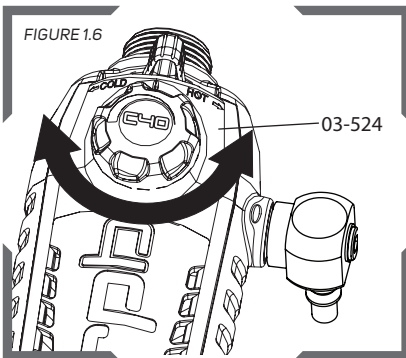

ADJUSTING THE TEMPERATURE

To obtain cooler air, turn the regulator control selector to the left. This will increase the air flow out of the exhaust port. Similarly, slide the selector to the middle, this will increase the temperature of the air closer to the ambient temperature of your air supply, then to the right for Hot Air as shown in Figure 1.7.

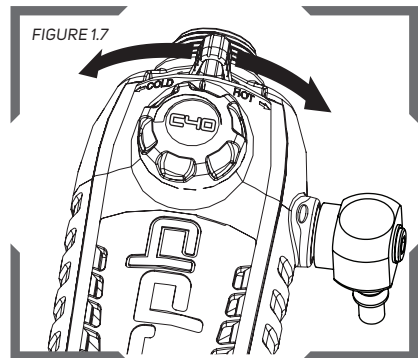

IMMEDIATELY LEAVE THE WORK AREA AND REMOVE THE RESPIRATOR IF ANY OF THE FOLLOWING OCCUR:

- The flow of air ceases or decreases.
- You feel ill (nauseous, dizzy, hot or cold)
- You feel breathless or have difficulty breathing.
- Any component in the respirator assembly becomes damaged.
- The pressure at the point of attachment dips below that recommended.
- You can see, smell or taste contaminants inside the respirator.
- You cannot see clearly

!WARNING! Do not use the 03-500 on the cold setting when ambient temperature is below 68° (20°C) as ice could form in the cold air outlet resulting in insufficient airflow.

RPB® C40™ CLIMATE CONTROL

RESPIRATOR ASSEMBLY & SETUP CONTINUED

AIR SUPPLY HOSES

Inspect the Air Supply Hose for cuts, cracks, blisters and excessive wear. Ensure the hose has not been crushed or kinked and that fittings are tightly crimped to the hose so air cannot escape. Replace the hose immediately if there are any signs of damage or wear.

Do not run water through the inside of the hose. Check Quick Disconnect Couplings and use compressed air to remove any particles that may jam the coupler.

INSPECTION, CLEANING AND STORAGE

The RPB® C40™ Climate Control Device has a limited service life, and therefore a regular inspection and replacement program must be conducted. All components of a Respirator Assembly including the Air Supply Hoses and Flow Control Devices should be inspected for damage and wear and tear, before use. If any damaged or worn parts are found, they should

be replaced immediately, or the Respirator disposed of. Use only parts and components that are part of the NIOSH approved respirator assembly as set out in this instruction manual or that of the Main respirator. Refer to the parts list on page 14-15 for the correct part numbers to replace parts of the C40™ Climate Control Device.

INSPECTION AND MAINTENANCE

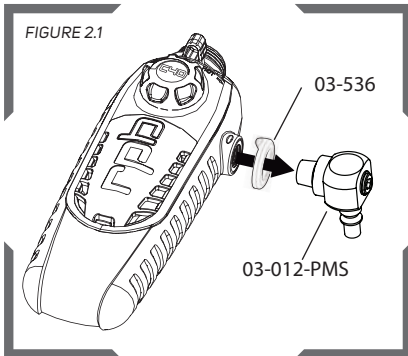

The first step is to use the allen key to unscrew the Swivel Connector (03-012-PMS) from the body of the C40. Unclip the (03-536) from the C40 (03-500).

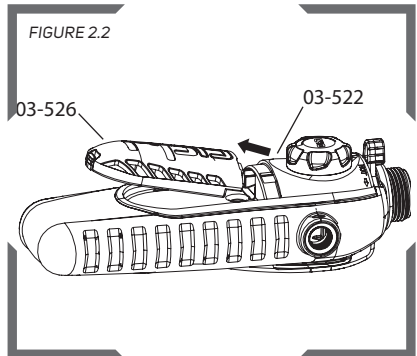

1. Push the clip tab on the Exhaust Cover (03-526) in until it unclips from Exhaust Case (03-522). 2. Lift up the (03-526) and slide it out of the (03-522).

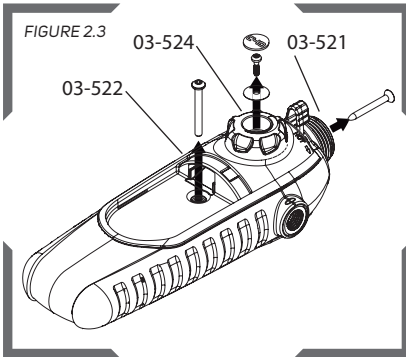

Remove the Cap from the Flow Knob (03-524) and then the screw and washer in the (03-524), as well as the screw from the Exhaust Case (03-522) and Top Casing (03-521) as shown in Figure 2.3.

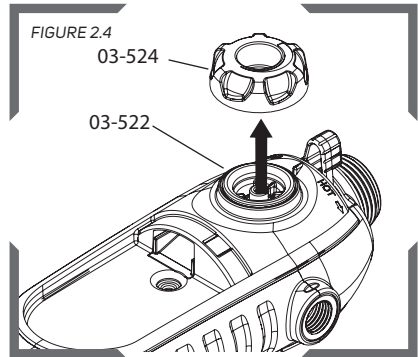

Remove the Flow Knob (03-524) from the Exhaust Case (03-522).

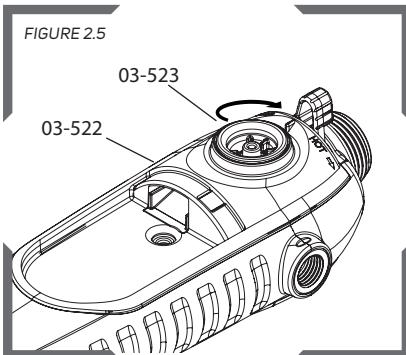

While pressing down firmly on Exhaust Case (03-522) turn the Flow Valve (03-523) 180° clockwise.

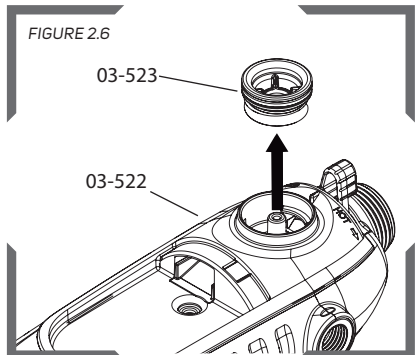

Remove the Flow Valve (03-523) from the Exhaust Case (03-522), taking care that the small center o-ring stays in place.

rpb[®] C40™ CLIMATE CONTROL

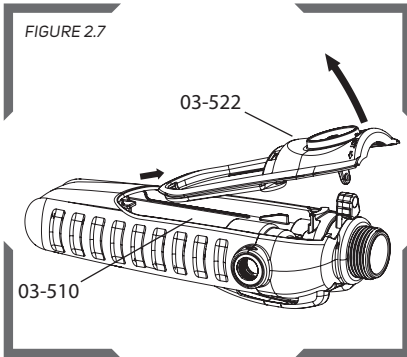

1. Lift the Exhaust Case (03-522) up from the U Tube (03-510) 2. Slide the 03-522 out from the 03-510.

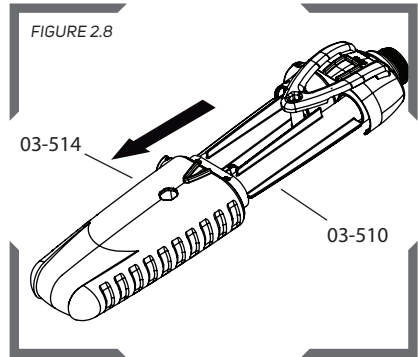

Lift the Belt Loop over the Bottom Case (03-514) to allow it to slide down off of the U Tube (03-510).

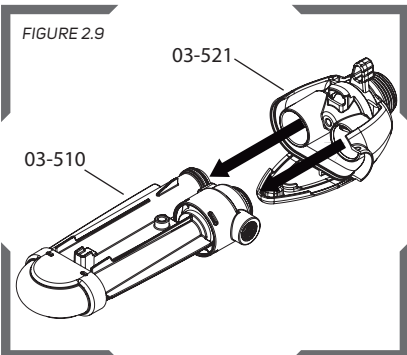

To finish disassembly of your C40, take the U Tube (03-510) and slide it off of Top Case (03-521). Inspect all parts for defects and clean with water and mild detergent. Dry all parts and reassemble.

Note:

To assist in assembly, fit the belt before installing the screws as per Figure 2.3.

Silencer plates are included in part 03-526 (Exhaust Cover and Silencers). These must be fitted when the 03-500 is in use.

FLOW AND TEMPERATURE CHART

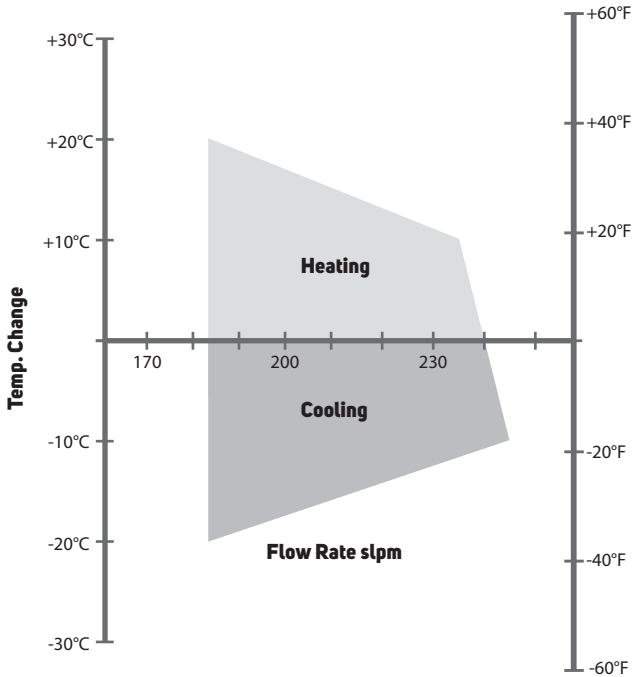

FIGURE 3.1

PARTS LIST

Item No.	Description	Part Number
1	U Tube Assembly	03-510
2	Bottom Case	03-514
3	Top Case Assembly	03-521
4	Exhaust Assembly	03-522
5	Silencer Assembly	03-526
6	Silencers	03-537
7	RPB® Quick Disconnect Swivel Plug	03-012-PMS
	RPB® RZ Quick Connect Swivel Plug	03-052-PMS-RZ
	RPB® Safety Quick Disconnect Swivel Plug (CE Only)	03-022-PMS
	Schrader Swivel Plug	03-042-PMS
8	Inlet Collar	03-536
9	Belt Loop and Nut	03-538

PARTS LIST CONTINUED

FIGURE 4.1

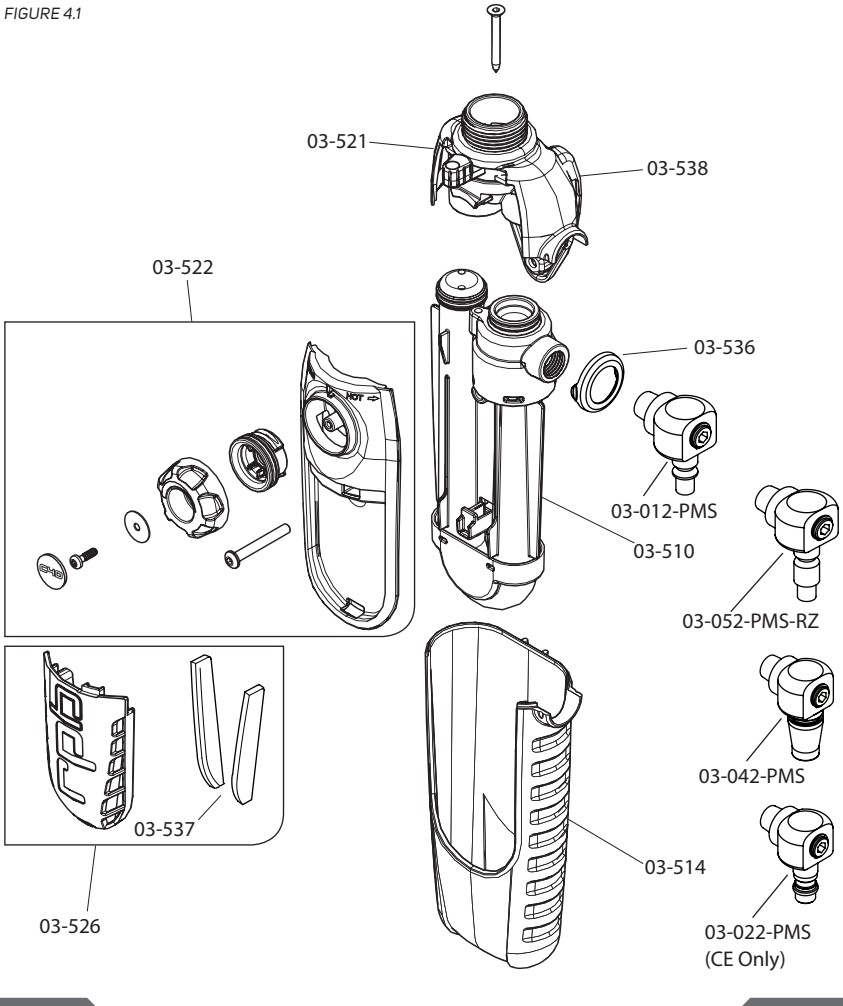

!WARNING! Use only parts and components that are part of the NIOSH approved respirator assembly. The use of non RPB® parts voids the NIOSH approval of the entire respirator assembly.

APPENDIX A1 - SCHRADER

1. AIR SOURCE	2. BREATHING TUBE ASSEMBLY AND FLOW CONTROL DEVICES	3. AIR SUPPLY HOSE	4. SUPPLY HOSE LENGTH (FT)	5. MAX NUMBER OF SECTIONS	6. PRESSURE RANGE (PSIG AIR)
Portable or Stationary Compressor	Astro or Nova 2000 NV2021 03-500	04-342-25 (25ft) 04-342-50 (50ft) 04-342-100 (100ft)	25	1	60-80
			50	1	65-85
			100	2	70-95
			150	3	75-95
			200	4	80-100
			250 300	5 6	85-100 95-100
Portable or Stationary Compressor	Nova 3 NV2021B 03-500	04-342-25 (25ft) 04-342-50 (50ft) 04-342-100 (100ft)	25	1	60-80
			50	1	65-85
			100	2	70-95
			150	3	75-95
			200	4	80-100
			250 300	5 6	85-100 95-100
Portable or Stationary Compressor	Z-Link or T-Link 04-830 03-500	04-342-25 (25ft) 04-342-50 (50ft) 04-342-100 (100ft)	25	1	60-80
			50	1	65-85
			100	2	70-95
			150	3	75-95
			200	4	80-100
			250 300	5 6	85-100 95-100

rpb C40™ CLIMATE CONTROL

NOTES

A series of horizontal dotted lines for taking notes.

NOTES

.....

.....

.....

.....

.....

.....

.....

.....

.....

.....

.....

.....

.....

.....

.....

.....

.....

.....

.....

.....

.....

.....

.....

.....

.....

.....

.....

OTHER PRODUCTS

ISO9001
CERTIFIED COMPANY

RPB® NOVA 3® RESPIRATOR

The RPB® NOVA 3® combines breakthrough protection technology with advanced comfort and functionality, surpassing even the most rigorous industry standards and the demands of the most quality-conscious companies. Designed to optimize safety and productivity, and to minimize worker downtime, the helmet has a host of features that maximize its lifetime value.



AIRLINE FILTRATION

The RPB® RADEX AIRLINE FILTER™ offers increased capacity, versatility and filtration. This optional equipment combines the versatility of either floor or wall mounting with increased filtration capacity, enabling customization to meet worker's needs and working environments.



AIR QUALITY MONITORING

Do you need an intelligent gas monitor that can give you complete confidence in the air you and your employees are breathing? The RPB® GX4® Gas Monitor has the ability to detect up to 4 gases simultaneously, giving you total peace of mind.



1866 494 4599
www.rpbsafety.com

rpb®
ADVANCING
YOUR SAFETY