

Hustler® Z Diesel General Service Manual

***SMOOTHTRAK™
STEERING***



HUSTLER®
ENGINEERING PERFORMANCE™

200 South Ridge Road
Hesston, Kansas
67062

WARNING

The engine exhaust from this product contains chemicals known to the state of California to cause cancer, birth defects or other reproductive harm.

NOTICE OF REQUIREMENT OF SPARK ARRESTER MUFFLER

This equipment may create sparks that can start fires around dry vegetation. California Public Resources Code Section 4442.6 provides that it is unlawful to use or operate an internal combustion engine on any forest-covered, brush-covered, or grass-covered land unless the engine is equipped with a spark arrester maintained in effective working order. A spark arrester is a device constructed of nonflammable materials specifically for the purpose of removing and retaining carbon and other flammable particles over 0.0232 of an inch in size from the exhaust flow of an internal combustion engine that uses hydrocarbon fuels or which is qualified and rated by the United States Forest Service. Other states or federal areas may have similar laws. The Operator Should Contact Local Fire Agencies For Laws or Regulations Relating to Fire Prevention Requirements. **THIS EQUIPMENT DOES NOT HAVE A SPARK ARRESTER AND YOU SHOULD CONTACT YOUR AUTHORIZED DEALER FOR THE PURCHASE OF A SPARK ARRESTER.**

Inspect spark arrester daily; replace every 500 hours or as needed.

The Engine Owner's Manual provides information regarding the U.S. Environmental Protection Agency (EPA) and the California Emission Control Regulation of emission systems, maintenance and warranty.

Keep Engine Owner's Manual with your unit. Should the Engine Owner's Manual become damaged or illegible, replace immediately. Replacements may be ordered per the information found in the Product Information section of the owner's manual.

Federal law and California State law prohibit the following acts or the causing thereof:

1. The removal or rendering inoperative by any person other than for purposes of maintenance, repair, replacement, of any device or element of design incorporated into any equipment for the purposes of emissions control prior to or after its sales or delivery to the ultimate purchaser or while it is in use, or
2. The use of the equipment after such device or element of design has been removed or rendered inoperative by any person.

Table of Contents

General Information	1-1
Service Program	1-1
Maintenance Introduction	1-1
Warranty	1-1
Safety	2-1
Safe Servicing Practices	2-1
Understand Correct Service	2-1
Pre-Operation Precautions	2-1
Operation Precautions	2-2
Operate Machine Safely	2-2
General Maintenance Precautions	2-2
Maintenance Precautions	2-3
Torque	3-1
Standard Torques	3-1
Special Torques	3-1
Power Unit Maintenance	4-1
Steering Adjustments	4-1
Park Brake Adjustment	4-4
Belts	4-6
Hydraulic Pump Belt Adjustment	4-6
Hydraulic System	4-7
Warner Clutch Re-gap Adjustment Procedures	4-9
Tires	4-12
Tapered Wheel Bearing Replacement	4-12
Engine Maintenance	5-1
General Engine Maintenance	5-1
Engine Oil and Filter	5-1
Engine Air Filter	5-1
Engine RPM Settings	5-3
Deck Adjustments	6-1
Deck Leveling	6-1
Blades	6-3
Belts	6-5
Deck Belt Adjustment	6-5
Deck Belt Routing & Tensioning	6-7

Electrical	7-1
Maintenance Schedule.....	8-1
Maintenance Locator Chart	8-3
Troubleshooting	9-1

GENERAL INFORMATION

Service Program

This manual is part of a service package for the Hustler® Z Diesel mowers. Use of this manual in conjunction with other Hustler® mower and component manuals will provide the information necessary to service and maintain Hustler® Z Diesel mowers.

This General Service Manual is a service guide for use by Service Technicians. It provides the necessary information needed to perform normal maintenance requirements on these units.

The Parts Manual provides a complete parts listing for the unit. Use this manual when ordering parts.

The Operator's Manual provides fundamental operational information and operational safety that is needed when operating the mower.

The component manuals are furnished by the various manufacturers to be used for the troubleshooting and servicing of their components.

Maintenance Introduction

Regular maintenance is the best prevention for downtime or premature failure. The following pages contain suggested maintenance information and schedules which the operator/mechanic should follow on a routine basis.

Remain alert for unusual noises, they could be signaling a problem. Visually inspect the machine for any abnormal wear or damage. A good time to detect potential problems is while performing scheduled maintenance service. Correcting the problem as quickly as possible is the best insurance.

Clear away heavy build-up of grease, oil and dirt, especially in the engine compartment and under the seat platform areas; minute dust particles are abrasive to close-tolerance engine and hydraulic assemblies.

Daily inspect mower for grass clippings and wire and string tangles. The underside of the mower deck will collect a build-up of grass clippings and dirt, especially when grass is wet or has high moisture content. This build-up will harden, restricting blade and air movement and will probably show a lesser quality of cut. Therefore it should be removed routinely.

To do this it will be necessary to raise and block the deck, using jack stands or blocks, in the full up position and scrape the build-up from underneath.

Some repairs require the assistance of a trained service mechanic and should not be attempted by unskilled personnel. Consult your Hustler® Turf Equipment service center when assistance is needed.

Information included in this manual was current at the time of printing, but subsequent production changes may cause your machine to vary slightly in detail. Hustler® Turf Equipment reserves the right to redesign and change the machine as deemed necessary, without notification. If a change has been made to your machine which is not reflected in this service manual contact the Customer Service Department at Hustler® Turf Equipment for additional information.

Warranty

Warranty repair must be performed by a Hustler® Turf Equipment Authorized Dealer before warranty credit can be allowed.

SAFETY



This safety alert symbol is used to call attention to a message intended to provide a reasonable degree of PERSONAL SAFETY for operators and other persons during the normal operation and servicing of this equipment.

▲ DANGER ▲	– denotes immediate hazards which WILL result in severe personal injury or death.
---------------------------------------	--

▲ WARNING ▲	– denotes a hazard or unsafe practice which COULD result in severe personal injury or death.
--	---

Safe Servicing Practices

Refer to the *Safety Precautions* section of this manual for more service safety information.

Understand Correct Service

- ▲ Be sure you understand a service procedure before you work on the machine.
- ▲ Unauthorized modifications to the machine may impair the function and/or safety and affect machine life.
- ▲ If it is necessary to make checks with the engine running, always use two people - with the operator at the controls, able to see the person doing the checking.

Pre-Operation Precautions

Fuel Handling

- ▲ To avoid personal injury or property damage, use extreme care when handling diesel fuel. Diesel fuel is extremely flammable and the vapors are explosive.
 - A fire or explosion from diesel fuel can burn you and others and can damage property.
- ▲ Observe the usual diesel fuel handling precautions:

- Do not smoke while refueling. Extinguish all cigarettes, cigars, pipes and other sources of ignition.
 - Do not remove fuel cap or fill tank with engine running or while engine is hot. Clean up any diesel fuel spills.
 - If diesel fuel is spilled, do not attempt to start the engine but move the machine away from the area of spillage and avoid creating any source of ignition until diesel fuel vapors have dissipated.
 - Keep diesel fuel away from open flame or spark and store machine away from open flame or spark or pilot light such as on a water heater or appliances.
 - Refuel outdoors. Never refuel or drain the diesel fuel from the machine indoors, or while in an enclosed trailer or other enclosed area.
 - Never attempt to start the engine when there is a strong odor of diesel fuel fumes present. Locate and correct the cause.
 - Store diesel fuel in an approved container and keep it out of the reach of children. Never buy more than a 30-day supply of diesel fuel.
 - Do not fill fuel containers inside a vehicle or on a truck or trailer bed with interior carpets or plastic truck bed liners. Always place diesel fuel containers on the ground away from your vehicle before filling.
 - When practical, remove the machine from the truck or trailer and refuel the machine with its wheels on the ground. If this is not possible, then refuel such machine on the truck or trailer using a portable container and not a fuel dispenser nozzle. If a fuel dispenser nozzle must be used, keep the nozzle in contact with the rim of the fuel tank or container opening at all times until fueling is complete. Do not use a nozzle lock-open device.
 - Never use diesel fuel for cleaning parts.
 - Read and observe safety precautions elsewhere in this manual.
- ▲ Diesel fuel is harmful or fatal if swallowed.
 - ▲ Avoid prolonged breathing of vapors.
 - Long-term exposure to vapors can cause serious injury and illness.
 - ▲ Keep diesel fuel away from eyes and skin.
 - Keep face away from nozzle and fuel tank or fuel container opening.
 - If diesel fuel is spilled on clothing, change clothing immediately.

Understand Machine Operation

- ▲ Only qualified and trained personnel should operate the equipment.
- ▲ Carefully read the operator's manual and all manuals furnished with the attachments. Learn the location and purpose of all controls, instruments, indicators and labels.

Wear Protective Clothing

- ▲ Do not operate or service the equipment while wearing sandals, tennis shoes, sneakers, shorts or any type of loose fitting clothing. Long hair, loose clothing or jewelry may get tangled in moving parts. Always wear long pants, safety glasses, ear protection and safety shoes when operating or servicing this machine.
- ▲ Always wear adequate eye protection when servicing the hydraulic system and battery, or when grinding mower blades and removing accumulated debris.
- ▲ Prolonged exposure to loud noise can cause impairment or loss of hearing.
 - Always wear adequate ear protection, such as earplugs, when operating this equipment as prolonged exposure to uncomfortable or loud noises can cause impairment or loss of hearing.
 - Do not wear radios or music headphones while operating the machinery. Safe operation requires your full attention.

Operation Precautions

Avoid Fire Hazards

- ▲ Clean flammable material from machine. Prevent fires by keeping engine compartment, top of deck, exhaust area, battery, hydraulic lines, fuel line, fuel tank and operator's station clean of accumulated trash, grass clippings, and other debris. Always clean up spilled fuel and oil.

Start Engine Safely

- ▲ Avoid possible injury or death from machine runaway.
- ▲ Do not start engine by shorting across starter terminals.
- ▲ Before you start the engine:
 - Sit on the operator's seat.
 - Move control levers to the neutral/brake position.

Operate Machine Safely

- ▲ Refer to the unit's operator's manual for complete safety information on safe machine operation.
- ▲ Always maintain a safe distance from people and pets when mowing
- ▲ Always be aware of what is behind the machine before backing up.

- ▲ Never leave machine unattended with ignition key in switch, especially with children present.
- ▲ Follow daily and weekly checklists, making sure hoses are tightly secured and bolts are tightened.
- ▲ Always keep engine and machine clean, removing accumulated dirt, trash and other material from machine.
- ▲ Never put hands or feet under any part of the machine while it is running.
- ▲ Never attempt to start engine when there is a strong odor of gasoline fumes present. Locate and correct cause.
- ▲ Keep all safety shields and covers in place, except for servicing.
- ▲ Do not touch hot parts of machine.

General Maintenance Precautions

- ▲ Repairs or maintenance requiring engine power should be performed by trained maintenance personnel only.
- ▲ Never run the engine in an enclosed area unless exhaust is vented to the outside. Exhaust gases contain carbon monoxide which is an odorless and deadly poison.
- ▲ Unless specifically required, **DO NOT** have the engine running when servicing or making adjustments to the mower.
 - Park the mower on level ground
 - Disengage the deck clutch.
 - Place the steering control levers in the park brake position.
 - Lower the deck.
 - Stop the engine.
 - Remove the ignition key.
 - Disconnect the negative battery cable.
 - Wait for all movement to stop before adjusting, cleaning or repairing.
 - Repairs or maintenance requiring engine power should be performed by trained maintenance personnel only.
 - To prevent carbon monoxide poisoning, operate the engine in a well ventilated area only.
 - Read and observe all safety warnings in this manual.
- ▲ Before working on or under the deck, make certain engine cannot be accidentally started. Shut engine off, remove ignition switch key and disconnect negative battery cable for maximum safety.
- ▲ Except when changing or checking belt, **always** keep belt covers on mower deck for safety as well as cleanliness.

- ▲ Use a stick or similar instrument to clean under the mower making sure that no part of the body, especially arms and hands are under mower.
- ▲ Keep your machine clean and remove any deposits of trash and clippings, which can cause engine fires and hydraulic overheating as well as excessive belt wear. Clean up oil or fuel spillage.
- ▲ Allow the mower, especially the engine, to cool in a well ventilated area before storing inside a building or other enclosure.
- ▲ Always wear adequate eye protection when servicing the hydraulic system and battery, or when grinding mower blades and removing accumulated debris.
- ▲ Never attempt to make any adjustments or repairs to the mower drive system, mower deck or any attachment while the engine is running or deck clutch is engaged.
- ▲ Exercise caution when releasing spring tension from any of the belt idlers or when working with any of the deck lift components.
- ▲ Never work under the machine or attachment unless it is safely supported with jack stands. Make certain machine is secure when it is raised and placed on the jack stands. The jack stands should not allow the machine to move when the engine is running and the drive wheels are rotating. **Use only certified jack stands.** Use only appropriate jack stands, with a minimum weight rating of 2000 pounds to block the unit up. Use in pairs only. Follow the instructions supplied with the vehicle stands.
- ▲ Keep nuts and bolts tight, especially the blade attachment bolts. Keep equipment in good working condition.
- ▲ Never tamper with safety devices. Check their proper operation regularly.
- ▲ Exercise caution when working under the deck as the mower blades are extremely sharp. Wrap the blade(s) or wear gloves and use extra caution when servicing them.
- ▲ Use original Hustler® replacement parts or parts that are equivalent in overall performance.
 - The mower may not comply with the appropriate safety standards if aftermarket parts, accessories, or attachments are used.

Maintenance Precautions

Avoid Fire Hazards

- ▲ Be prepared if an accident or fire should occur. Know where the first aid kit and the fire extinguishers are located and how to use them.
- ▲ Provide adequate ventilation when charging batteries.
- ▲ Do not smoke near battery.
- ▲ Never check fuel level with an open flame.

- ▲ Never use an open flame to look for leaks anywhere on the equipment.
- ▲ Never use an open flame as light anywhere on or around the equipment.
- ▲ When preparing engine for storage, remember that fuel stabilizer is volatile and therefore dangerous. Seal and tape openings after adding the inhibitor. Keep container tightly closed when not in use.
- ▲ Inspect electrical wiring for worn or frayed insulation. Install new wiring if wires are damaged.

Prepare for Emergencies

- ▲ Be prepared if a fire starts.
- ▲ Keep a first aid kit and fire extinguishers available.
- ▲ Keep emergency numbers for doctor, ambulance service, hospital, and fire department near the telephone.

Prevent Battery Explosions

- ▲ Battery posts, terminals, and related accessories contain lead and lead compounds, chemicals known to the State of California to cause cancer and reproductive harm. Wash hands after handling.
- ▲ Charge batteries in a well-ventilated open area, away from sparks and flames. Unplug charger before connecting or disconnecting from battery. Wear protective clothing and use insulated tools.
- ▲ Avoid skin and clothing contact with battery acid.
 - Always wear eye protection when checking the battery. Acid can cause serious injury to skin and eyes. If contact occurs, flush area with clean water and call a physician immediately. Acid will also damage clothing.
 - Do not drink the battery electrolyte.
 - Do not allow open flame near the battery when charging.
 - Hydrogen gas forms inside the battery. This gas is both toxic and flammable and may cause an explosion if exposed to flame. Always **disconnect** the negative (black) battery cable(s) before disconnecting the positive (red) cable(s). Always **connect** the positive (red) battery cable(s) before connecting the negative (black) cable(s).
 - Do not overfill the battery.
 - Electrolyte may overflow and damage paint, wiring or structure. When cleaning the battery, use soap and water. Be careful not to get soap and water into the battery. Clean the battery terminals with a solution of four parts water and one part baking soda when they become corroded.
- ▲ Shorts caused by battery terminals or metal tools touching metal mower components can cause sparks.

Sparks can cause a battery gas explosion which will result in personal injury.

- Prevent the battery terminals from touching any metal mower parts when removing or installing the battery.
 - Do not allow metal tools to short between the battery terminals and metal mower parts.
- ▲ Incorrect battery cable routing could cause damage to the mower and battery cables. This can cause sparks which can cause a battery gas explosion which will result in personal injury.
- Always **disconnect** the negative (black) battery cable(s) before disconnecting the positive (red) cable(s).
 - Always **connect** the positive (red) battery cable(s) before connecting the negative (black) cable(s).

Avoid Acid Burns

- ▲ Sulfuric acid in battery electrolyte is poisonous. It is strong enough to burn skin, eat holes in clothing and cause blindness if splashed in eyes.

Avoid the hazard by:

- Filling batteries in a well-ventilated area.
- Wearing eye protection and rubber gloves.
- Avoiding breathing fumes when electrolyte is added.
- Avoiding spilling or contacting dripped electrolyte.

If you spill acid on yourself:

- Flush your skin with water.
- Apply baking soda or lime to help neutralize the acid.
- Flush your eyes with water for 10–15 minutes. Get medical attention immediately.

If acid is swallowed:

- Drink large amounts of water or milk.
- Then drink milk of magnesia, beaten eggs or vegetable oil.
- Get medical attention immediately.

TORQUE

Standard Torques

The following chart lists the standard torque values for the threaded fasteners found in this manual. Torque all cap screws, nuts and set screws to these values unless a different torque is shown in the *Special Torques* section.

Size	ft-lbs	N•m	Size	ft-lbs	N•m
#10	32.4 IN.-LBS.	3.6	M3	12 IN.-LBS.	1.3
.250	98.4 IN.-LBS.	11.1	M4	26.4 IN.-LBS.	3
.312	204 IN.-LBS.	23	M5	54 IN.-LBS.	6.1
.375	30	40	M6	92.4 IN.-LBS.	10.4
.438	48	65	M8	222 IN.-LBS.	25
.500	73	99	M10	37	50
.562	105	143	M12	64	87
.625	145	200	M14	103	140
.750	260	350	M16	160	215
.875	420	565	M20	320	435

Special Torques

Description	ft-lbs	N•M
Wheel (lug) nuts ¹	70	95
Blade spindle bolt top	70	95
Blade spindle bolt bottom	118	160
Electric clutch mounting bolt ³	45–48	61–65
Front wheel axle bolt	100	136
Wheel motor hub nut	230	312
Hydraulic pump pulley screw	14	19
Engine torques ²	N/A	N/A
Engine mount bolts	64	87

Notes:

- Lug nuts only** – It is recommended that these be checked after the first 2 hours of operation and every 40 hours and following removal for repair or replacement.
- Engine torque values** – Refer to the engine owner's manual.

- If clutch mounting bolt is loosened or removed, **do not re-use**. Replace with a new bolt. Use only hand tools to install this fastener.



Particular attention must be given to tightening the drive wheel lug nuts and blade spindle bolts. Failure to correctly torque these items may result in the loss of a wheel or blade, which can cause serious damage or personal injury.

POWER UNIT MAINTENANCE

Steering Adjustments

Steering control lever neutral adjustment

The mower's steering has been factory adjusted to eliminate creeping when the steering control levers are in the neutral position. However, should the mower begin to creep, the steering control lever linkage can be adjusted.

Before considering any adjustment, check the tire air pressure. Unequal tire pressure will cause the mower to drift to one side. Refer to tire pressure information in the *Tires* section for detailed information.

NOTE: Proper park brake adjustment must be completed before the steering control lever neutral adjustment can be done. Refer to the *Park Brake Spring Adjustment* section for detailed information.

Fine adjustment to the unit's steering is made with the transmission's control rod.

Neutral is properly adjusted when the steering control levers are in the park brake position and the transmissions do not "whine".

If this occurs, the steering control linkage may be adjusted as follows:

WARNING

This procedure will require that the unit be raised and blocked up off of the ground. It is necessary for the wheels to rotate without coming in contact with the floor or any object that would permit the unit to propel itself. Stay clear and exercise caution when rotating wheels to prevent injury. Use only appropriate vehicle stands, with a minimum weight rating of 2000 pounds to block the unit up. Use in pairs only. Follow the instructions supplied with the vehicle stands.

WARNING

Keep hands, hair, clothing, etc., clear of the cooling fans on top of the transmissions. Exercise extreme caution.

WARNING

Untrained maintenance personnel should never attempt to make any adjustments or repairs to the mower's drive system while the engine is running. The following procedures should be performed by trained maintenance personnel only.

1. Raise the rear of the mower and block with certified jack stands. The rear wheels need to be able to rotate freely and clear of all obstructions.

2. Chock the front tires.
3. Raise the seat platform and disconnect the mower harness from the seat switch. Bypass the seat switch by connecting the two mower harness female spades together. Figure 4-1

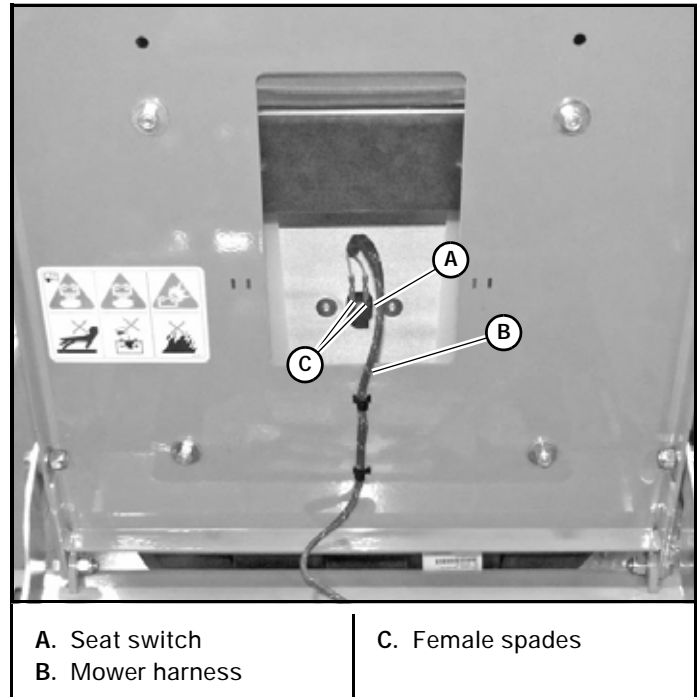

Figure 4-1

4. Start the engine.
5. Position the steering control lever in the neutral position and observe which way the wheels are rotating. Figure 4-6

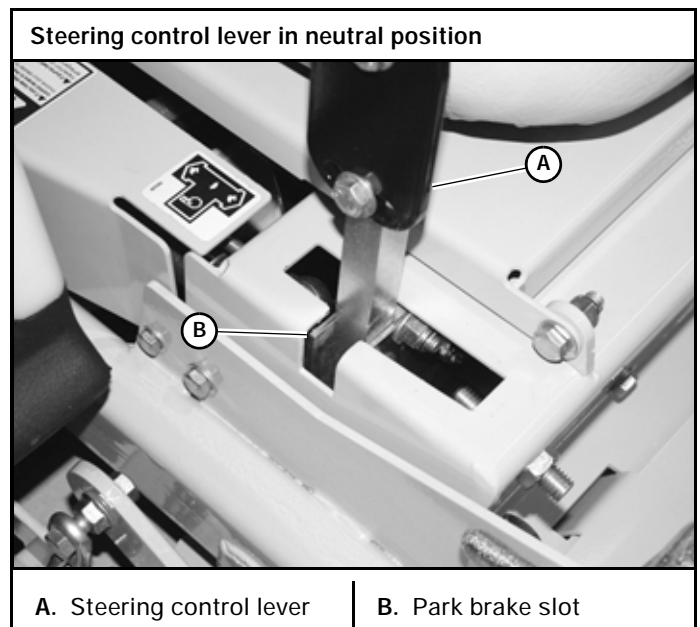
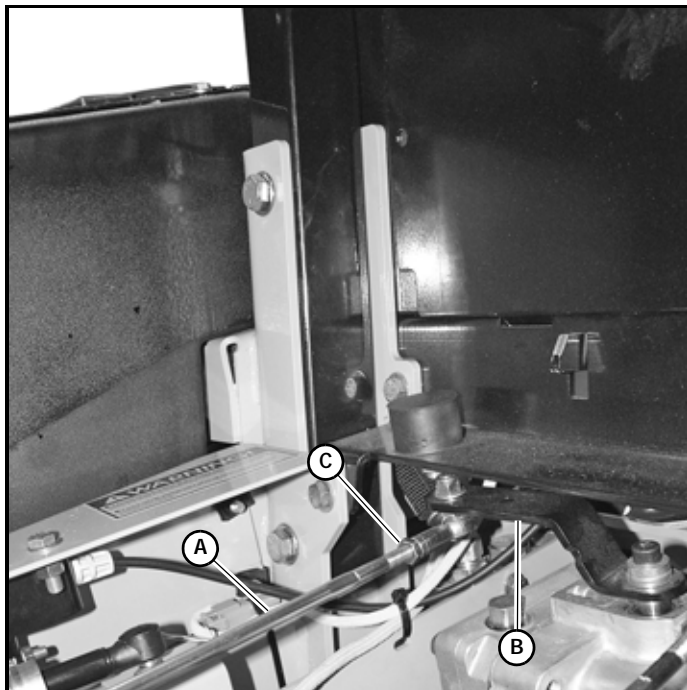

Figure 4-2

6. If wheel(s) are rotating forward, loosen the jam nuts on the pump linkage rods and rotate the rod to lengthen the steering control linkage until the wheel(s) come to a stop. Figure 4-3
7. Repeat for the opposite side if necessary.



A. Pump linkage rod
B. Pump arm

C. Jam nut

Figure 4-3

8. If wheel(s) are rotating in reverse then loosen the jam nuts on the pump linkage rods and rotate the rod to shorten the steering control linkage until the wheel(s) come to a stop. Figure 4-3
Repeat for the opposite side if necessary.
9. When both wheels remain in neutral, tighten the jam nuts to lock the turnbuckle in place.
10. Test again by moving the steering control levers forward and backward before returning them to the neutral position. If the tires are in neutral, the unit is now ready for operation.
11. After adjusting for neutral it may be necessary to re-adjust the control lever stop and/or damper.
12. **IMPORTANT:** With the engine off, disconnect the two female spade connectors from each other (from step #3) and reconnect them to the seat switch. This must

be completed so that the safety circuit is functioning properly. Figure 4-1



Do not operate the mower without plugging the mower's wiring harness into the seat switch. This switch is an important part of the safety start interlock system. Serious injury can result if the seat switch is not plugged into the mower's wiring harness.



Never operate the mower with a non-functioning seat switch. Always reconnect the seat switch to the mower harness.

13. Check to make sure all tools or obstructions are removed from under the mower.
14. Raise the rear of the mower and remove the jack stands. Lower the mower.
15. Lower and secure the seat platform.

Control lever stops

The steering control lever stops (see Figure 4-4) are designed to do two things: First, and most important, they must keep the pumps from bottoming out internally. Secondly, the stops may be adjusted to help drive straight when the steering control levers are pushed forward against the stops.

To keep the pumps from bottoming out internally use the following procedure:

This adjustment is only required if the hydraulic pump(s) have been replaced.



Pump damage will occur if these stops are set incorrectly.

1. To make the first adjustment the tractor engine must **not** be running.
2. Check to make sure the steering control levers are against the stops before the pumps are bottomed out internally.
3. To do this, gently and slowly move the steering control levers forward and feel if there is some resistance on the pump lever before the control levers hit the stops. Check one side at a time. If you sense that the pump arms are stopping the forward motion of the control arms, loosen the jam nut on the adjustable stop of the corresponding side, turn the stop (set screw) inward to

stop the steering control levers slightly before the pump bottoms out. Lock in place when the adjustment is correct by re-tightening the jam nut. Do this for each side.

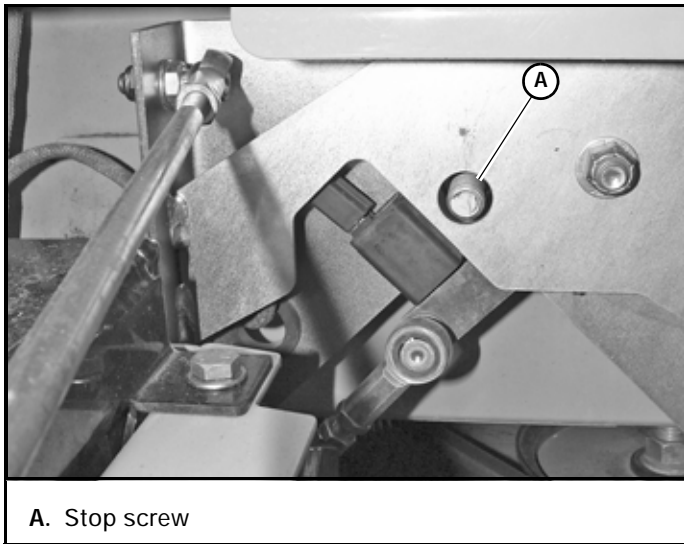

Figure 4-4

To adjust the stops for driving straight when steering control levers are against the stops during operation:

1. Determine which drive tire is rotating too fast when both steering control levers are against the stops in the control panel. Figure 4-5
2. Then, stop the tractor and loosen the lock nut on the side which is rotating too fast and turn the stop (set screw) inward to stop the steering control lever sooner. Tighten the lock nut on the stop and test again.
3. Repeat this procedure until unit drives straight.

NOTE: Since this is a hydrostatic drive, variables such as temperature of oil, efficiency of pumps and motors, tire pressure etc. may effect the consistency of the ability to rely on the stops to drive straight without the operator making minor steering adjustments with the control arms.

Steering damper

The steering dampers are spring loaded to return the control levers to the neutral position from the reverse position. This gives the operator a sense of neutral during operation.

To set the steering dampers in the correct operating position follow these steps:

1. Shut engine off, place steering control levers in the park brake position, disengage deck clutch, remove ignition switch key and disconnect negative battery cable before doing any adjustments.

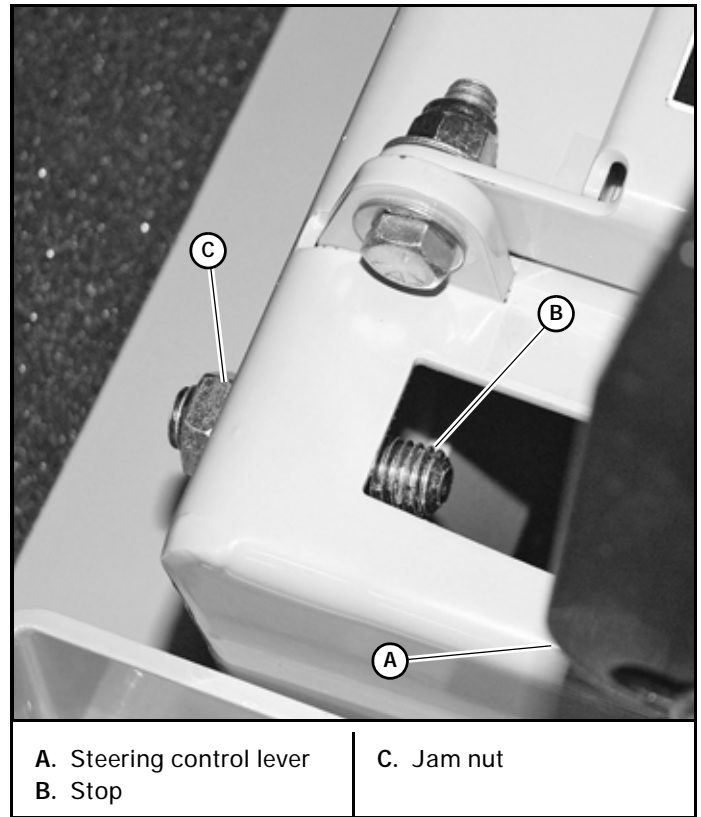

A. Steering control lever	C. Jam nut
B. Stop	

Figure 4-5

2. Place the steering control lever in the park brake position. Figure 4-6
 3. Loosen the steering damper's rear ball stud. Figure 4-7
 4. Pull the damper spring housing past the point that the internal spring is engaged. Figure 4-7
 5. Release the damper spring housing and allow the internal spring to bring the housing back to the neutral position.
 6. Tighten the nut on the steering damper's front ball stud.
- NOTE:** The damper must not bottom out when the pump lever is fully stroked in either direction.
7. Reconnect the negative battery cable.
 8. Lower and secure the seat platform.
 9. To check, move the steering control lever to the reverse position and release. The steering control lever should return to the neutral position. If not, repeat steps 1 through 6.

Steering control lever adjustment

The steering control levers can be adjusted for operator comfort.

1. By loosening the cap screws that attach the upper control lever to the lower lever the upper control lever can be pivoted to fit the operator's personal preference. Figure 4-8

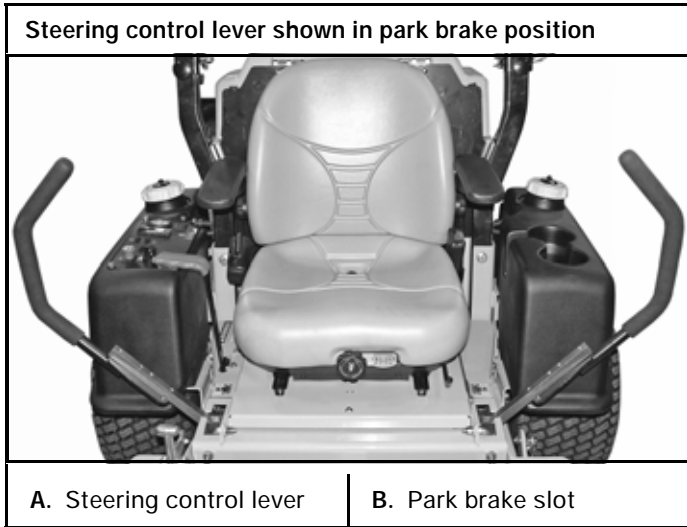

Figure 4-6



Figure 4-7

- The steering control levers should be adjusted so that they align vertically with each other when in the neutral position. Figure 4-9

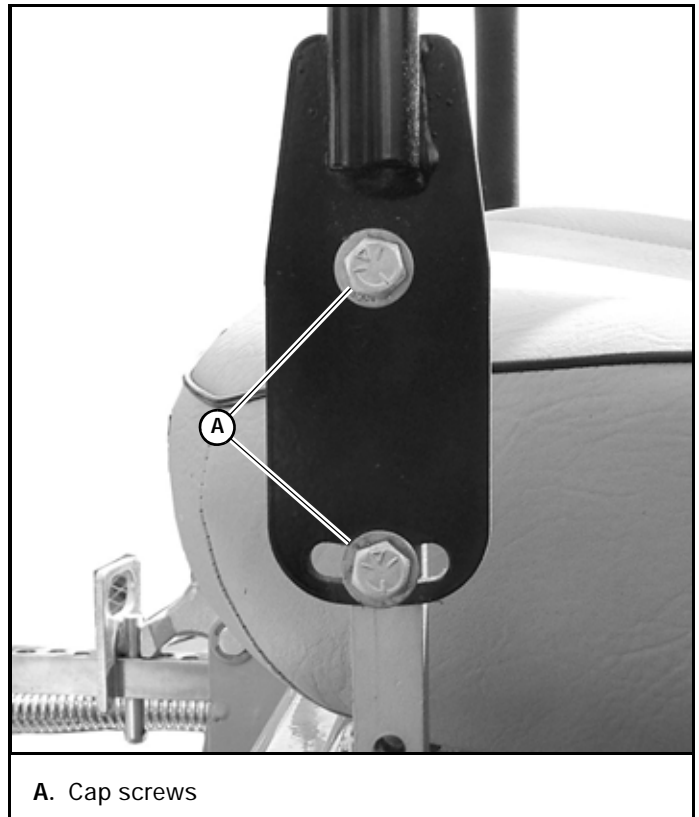

Figure 4-8

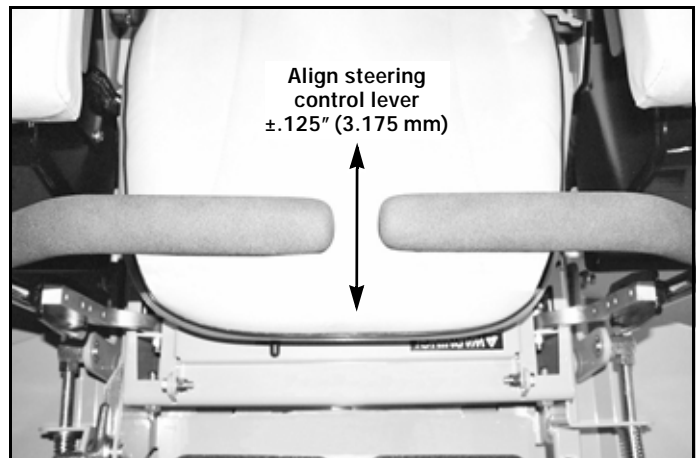

Figure 4-9

Park Brake Adjustment

WARNING ⚠ This procedure will require that the unit be raised and blocked up off of the ground. It is necessary for the wheels to rotate without coming in contact with the floor or any object that would permit the unit to propel itself. Stay clear and exercise caution when rotating wheels to prevent injury. Use only appropriate vehicle stands, with a minimum weight rating of 2000 pounds to block the unit up. Use in pairs only. Follow the instructions supplied with the vehicle stands.

1. Shut engine off, place steering control levers in the park brake position, disengage deck clutch, remove ignition switch key and disconnect negative battery cable before doing any adjustments.
2. Raise the rear of the mower and block with certified jack stands. The rear wheels need to be able to rotate freely and clear of all obstructions.
3. Chock the front tires.
4. Position the steering control levers in the neutral position.

NOTE: The front brake link is not to be adjusted. Figure 4-10

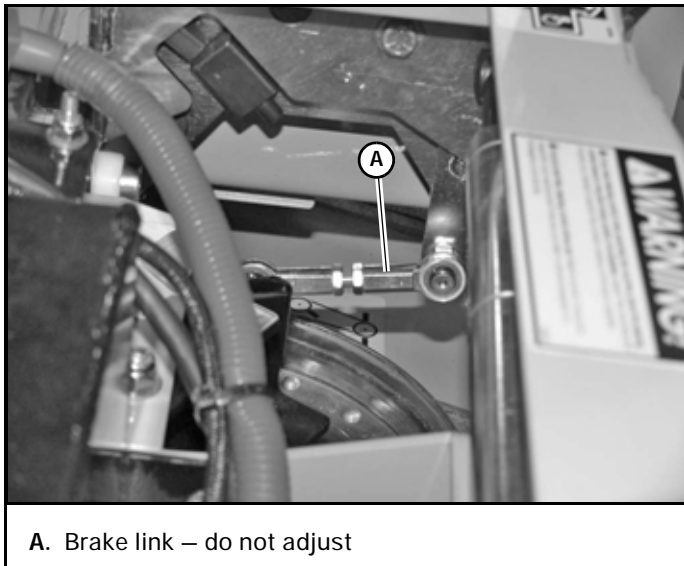

Figure 4-10

5. Open the hydraulic pump's bypass valve, on the side that is being adjusted, by turning the bypass valve counter clockwise one-half to one revolution. Figure 4-11

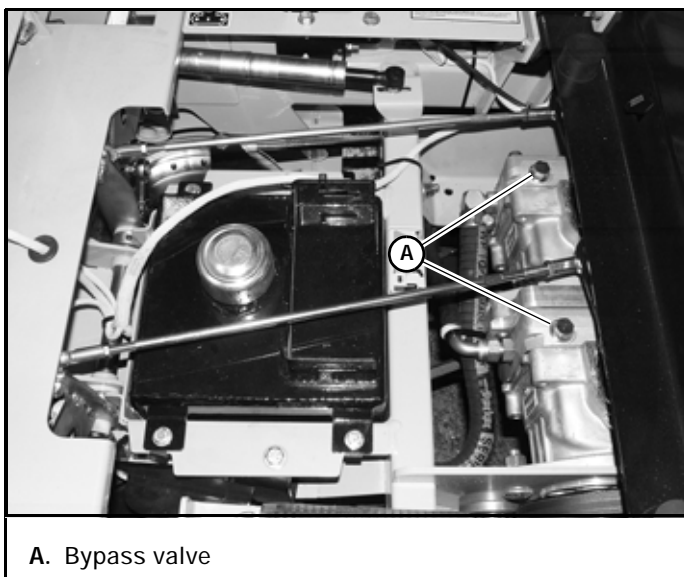

Figure 4-11

6. Try and rotate the tire by hand. The tire should rotate. Remember hydraulic oil resistance will prevent the tire

from rotating freely even with the bypass valves open. There should be no resistance from the brakes at this point.

7. Move the steering control lever to where it is just inside (1/4" [6.35 mm]) the park brake slot. Figure 4-12

NOTE: When the steering control lever is against the outside edge of the slot, the brakes should **not** be engaged.

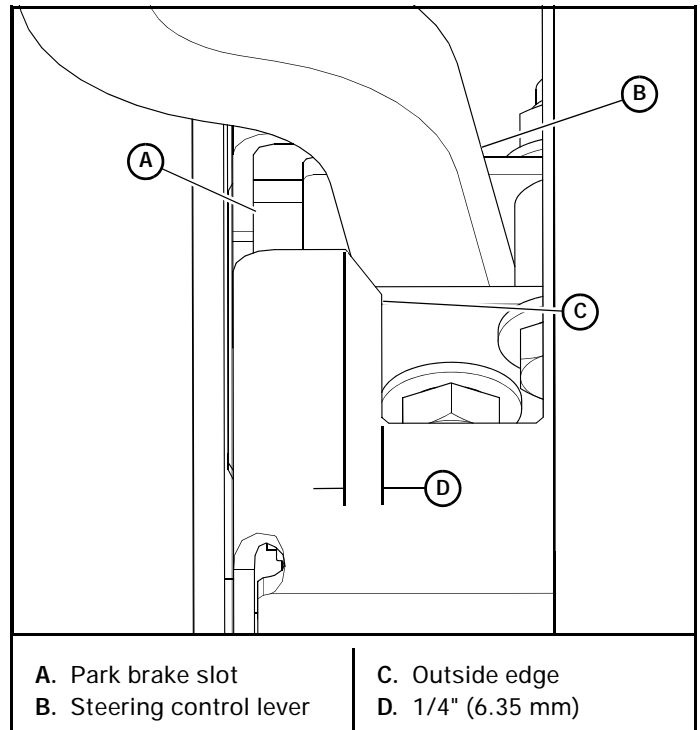

Figure 4-12

8. Rotate the tire. If the brake is adjusted properly the tire will still rotate but friction will start to become noticeable here. However, if no brake resistance is noticed, the brake needs adjusted as follows:
 - a. Loosen the brake linkage jam nuts. (Figure 4-13)
 - b. Rotate the tire and at the same time rotate the turnbuckle to shorten the length of the brake linkage to increase the brake pressure. When you feel the brake begin to engage, stop adjusting the turnbuckle. Re-tighten the jam nuts on the turnbuckle.
 - c. Place the control lever in the park brake slot. The tire should not rotate when the control lever is in the park brake position. Figure 4-12
 - d. Place the control lever in the neutral position. The tire should rotate freely.
9. Close the hydraulic pump's bypass valve. Figure 4-11
10. Repeat steps 4 through 9 for the other side.
11. Check to make sure all tools or obstructions are removed from under the mower.
12. Raise the rear of the mower and remove the jack stands. Lower the mower.
13. Reconnect the negative battery cable.
14. Lower and secure the seat platform.

Hydraulic Pump Belt Adjustment

The transmission drive belt tension remains constant by means of a tension idler and spring. The spring tension should be such that the belt does not slip under normal operating load conditions, assuming the belt is not excessively worn or damaged. As the belt stretches and wears in, adjustment may become necessary.

The proper belt tension is achieved when the tension spring is stretched to a dimension of $9.50" \pm .13"$ (241.3 ± 3.3 mm) when measured from the inside of the hook to the inside of the other hook. Figure 4-14

To increase belt tension, loosen the jam nut on the eye bolt. Then, tighten the nut on the eyebolt until the $9.50" \pm .13"$ (241.3 ± 3.3 mm) dimension is attained. Lock the eyebolt in place by tightening the jam nut. Figure 4-14

IMPORTANT: Do not over tension the spring to compensate for a badly worn belt or pulley. Figure 4-14

IMPORTANT: Inspect the belt every 100 hours and replace as needed. Replace the belt every 400 hours or every two (2) years whichever comes first.

WARNING	⚠
	<p>If the transmission belt fails, loss of control will occur especially when operating on a slope. If you lose steering control while operating the machine, place the steering control levers in the park brake position immediately. Inspect the machine and involve your dealer to resolve the problem.</p>

A. Spring	D. Eyebolt
B. Jam Nut	E. $9.50" \pm .13"$ ($241.3 \text{ mm} \pm 3.3 \text{ mm}$)
C. Nut	

Figure 4-14

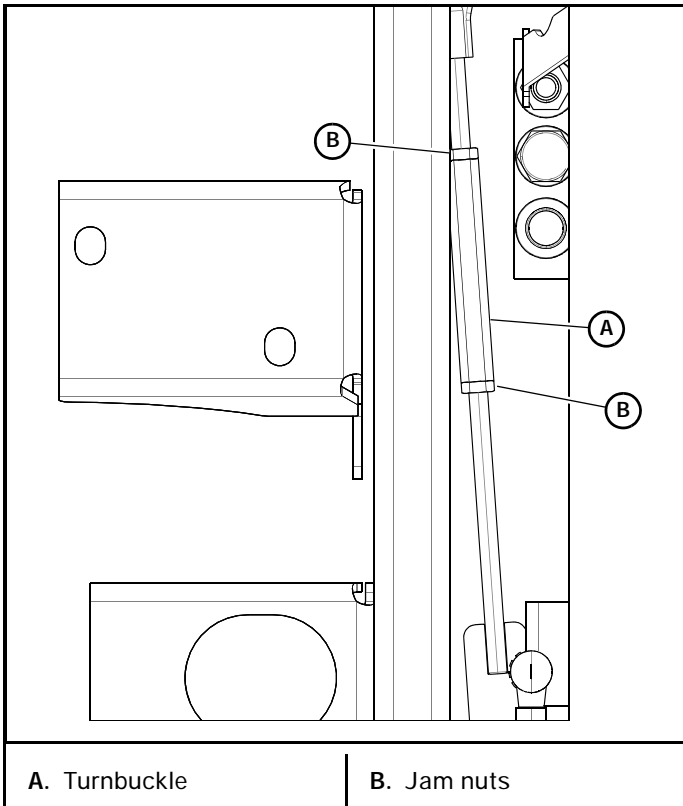

Figure 4-13

Belts

Inspect belts frequently for wear and serviceability. Replace a belt that shows signs of:

- severe cuts
- tears
- separation
- weather checking
- cracking
- burns caused by slipping.

Slight raveling of belt covering does not indicate failure, trim ravelings with a sharp knife.

Inspect the belt pulley grooves and flanges for wear. A new belt, or one in good condition, should never run against the bottom of the groove. Replace the pulley when this is the case, otherwise, the belt will lose power and slip excessively.

Never pry a belt to get it on a pulley as this will cut or damage the fibers of the belt covering.

Keep oil and grease away from belts, and never use belt dressings. Any of these will destroy the belt composition in a very short time.

Hydraulic System

IMPORTANT: Never use hydraulic or automatic transmission fluid in this system; use only motor oil as specified. Remember, dirt is the primary enemy of any hydraulic system.

WARNING

Hydraulic fluid escaping under pressure may have sufficient force to penetrate skin and cause serious injury. Foreign fluid injected into the skin must be surgically removed within a few hours by a doctor, familiar with this form of injury, or gangrene may result.

Before applying pressure to hydraulic system, make sure all connections are tight and all hoses and lines are in good condition. To find a leak under pressure, use a piece of cardboard or wood — **never** use your hands. Relieve all pressure in the system before disconnecting or working on hydraulic lines. To relieve pressure, lower all attachments and shut off engine.

Check oil level in hydraulic system after every 50 hours of operation or weekly, whichever occurs first. Check more often if system appears to be leaking or otherwise malfunctioning.

Fluid level should be 1" (25.4 mm) from top of reservoir. Figure 4-15

Use only **SAE 20W50 motor oil, 15W50 synthetic oil, or 20W50 synthetic oil.** Hustler® Full Synthetic 20W50 Hydrostatic Transmission Oil is recommended.

NOTE: The reservoir will require approximately 7 U.S. quarts (6.6 liter) of **SAE 20W50 motor oil, 15W50 synthetic oil, or 20W50 synthetic oil** when replacing the oil after an oil and filter change. **Do not** overfill the reservoir. Figure 4-15

Initial system oil and filter change **must** be after the first 50 hours of mower operation. Then replace the filter and oil in the reservoir **annually or every 500 hours, whichever comes first.** Figure 4-16

IMPORTANT: It is necessary to drain the system oil from the hydraulic reservoir, using the reservoir drain plug, before removing the hydraulic filter. Replace the drain plug before adding system oil.

The hydraulic system filter is located inside the hydraulic reservoir on the rear underneath side of the tank. Use a 5/8" socket to change the filter, threads are right handed. Use a **Hustler® Turf Equipment approved filter element only.**

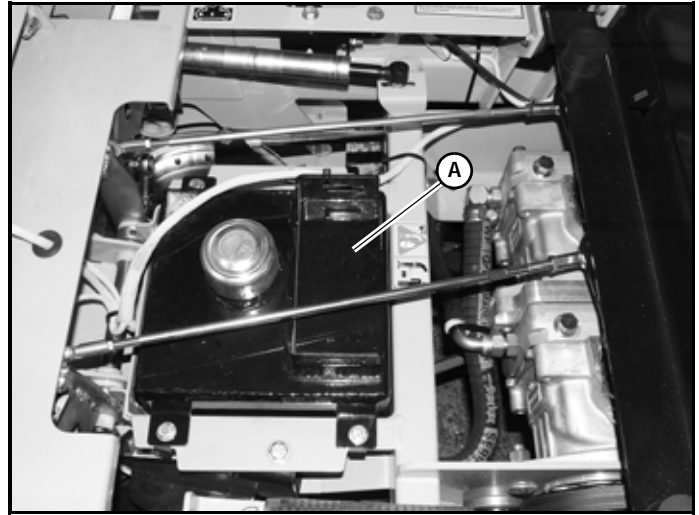

A. Hydraulic reservoir

Figure 4-15

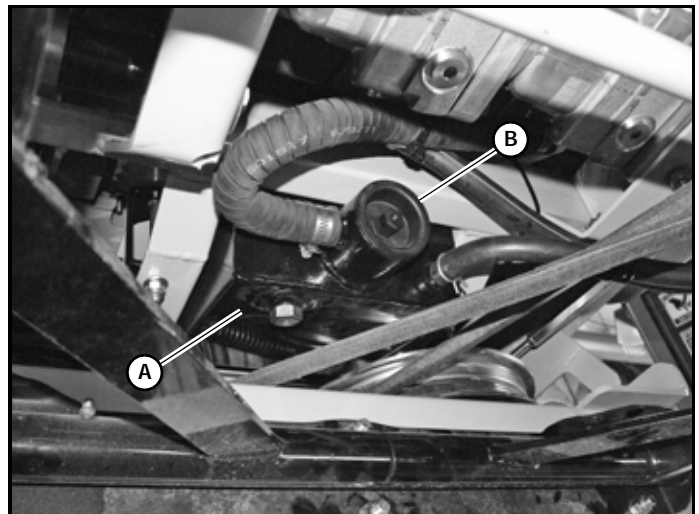

A. Hydraulic reservoir

B. Hydraulic filter

Figure 4-16

Hydraulic oil heat exchanger

These mowers are equipped with a hydraulic oil heat exchanger. The heat exchanger coils must be kept clean to insure that the hydraulic oil is operating within the correct temperature range.

Check and clean the heat exchanger daily and more often in dirty, dusty conditions. Figure 4-17

Hydraulic pump flow test

The design purpose of the Bi-Directional Flow Test Kit is to allow the technician to isolate the pump from the wheel motor and determine if the pump is acceptable. The

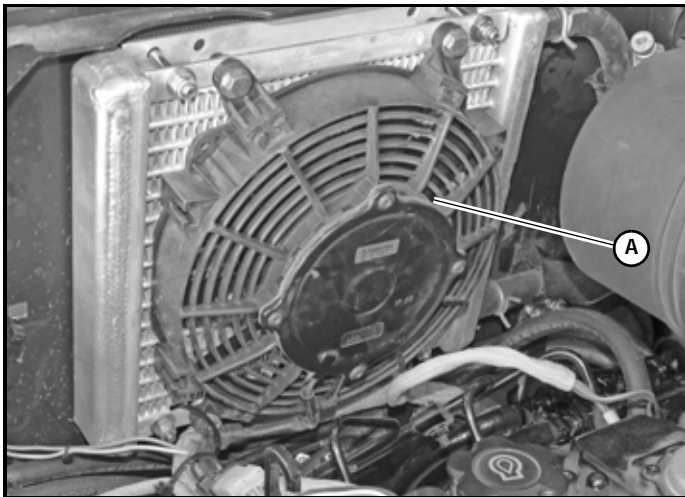

A. Heat exchanger

Figure 4-17

following information can be used to install and test the pump by simulating a wheel motor load.

WARNING

Certain procedures require the vehicle engine to be operated and the vehicle to be raised off of the ground. To prevent possible injury to the servicing technician and/or bystanders, make sure the vehicle is properly secured.

WARNING

Do not attempt any adjustments with the engine running. Use extreme caution while working in or around all vehicle linkage! High temperatures can be generated. Follow all safety procedures outlined in the vehicle owner's manual!

Installation & testing procedures

Disconnect the system hoses at the wheel motor, or system hoses from the pump and connect the Bi-Directional Flow Test Kit. (Special care should be taken to prevent contamination debris from entering pump or wheel motor system ports).

NOTE: Using the Bi-Directional Flow Test Kit, determination of directional flow is not necessary. The flow meter may be connected in either direction into the forward and reverse high pressure system lines.

NOTE: The following adapter fittings will be required when connecting the Bi-Directional Test Kit (Excel P/N 783886 or Hydro-Gear P/N 70661):

TC (21) Series Pumps require two 771311 adapter fittings.

CAUTION: Make sure all fittings and hoses are attached securely. This test is being completed on the vehicle's high pressure system lines. Failure to perform this properly could result in bodily injury.

Testing Procedures

1. Use approved jack stands to raise the drive wheels off the floor.

WARNING

Never work under the machine or attachment unless it is safely supported with jack stands. Make certain machine is secure when it is raised and placed on the jack stands. The jack stands should not allow the machine to move when the engine is running and the drive wheels are rotating. Use only certified jack stands. Use only appropriate jack stands, with a minimum weight rating of 2000 pounds to block the unit up. Use in pairs only. Follow the instructions supplied with the vehicle stands.

2. Open the restriction valve all the way.
3. For the pump being tested, move the steering control levers in full forward motion. (It will be necessary to lock the steering control levers into full forward position to prevent false readings).
4. Operate without any load for approximately 30 seconds to 1 minute. This allows the system oil temperature to rise.

NOTE: Raising the system oil temperature will make a difference in the readings you receive. It has been determined that to complete this test accurately, the oil temperature must be near system operating temperatures. Suggested temperature range 160°–210° F (71.1°–98.9° C).

5. Increase the throttle until the flow meter reads 12 gpm–15 gpm (45.43 l/min–56.78 l/min). Leave the throttle set in this position.

CAUTION: Damage to the flow meter and/or re-calibration may result from testing at input speeds that exceed 15 gpm (56.78 l/min).

6. With the engine running at the rpm setting established in step 5, tighten the flow meter restriction valve until the gauge reads 300 psi (21 bar).

Record the flow reading on the Bi-Directional Flow Meter.

7. Increase the pressure to 1100 psi (76 bar).

Record the flow reading on the Bi-Directional Flow Meter.

8. The acceptable gpm "flow droop" or (difference) is:

TC (21)	2.5 gpm (9.4 l/min)
---------	---------------------

If the difference exceeds these values the pump would not be operating efficiently and should be replaced or repaired. See the following example.

Test Example: TC (21) Pump

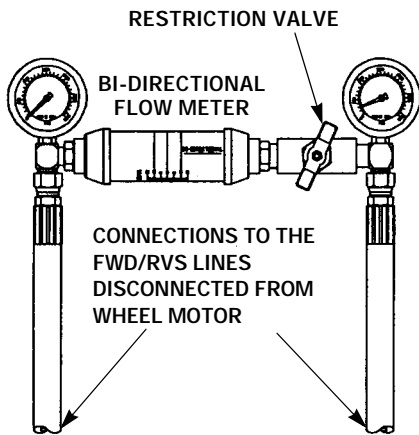

300 psi (21 bar) reading

9 gpm (34 l/min) (1st reading)

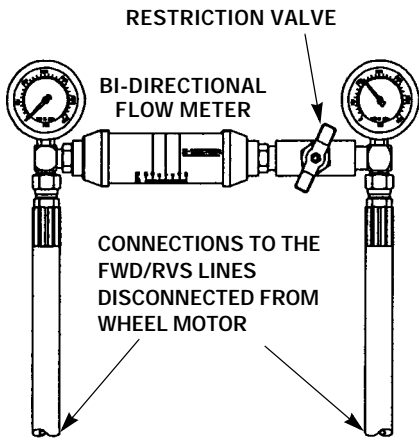

1100 psi (76 bar) reading

5 gpm (19 l/min) (2nd reading)

PK (12)

300 psi (21 bar) reading

9 gpm (34 l/min) (1st reading)

1100 psi (76 bar) reading

-5 gpm (19 l/min) (2nd reading)

4 gpm (15 l/min) (the difference)

Subtract the 1st reading from the 2nd.

(In this example, 4 gpm difference would indicate further pump examination).

Warner Clutch Re-gap Adjustment Procedures

The air gap is only adjustable on clutches that have a removable shim (see Figure 4-22).

When to remove shim:

When a clutch has worn to the extent that the existing air-gap is too large to allow for complete clutch engagement (clutch may engage easily when cold but has problems engaging when hot), the brake shim can be removed to reduce air gap and allow the clutch to continue to function.

After verifying that proper voltage and current are supplied to the clutch, follow the procedure outlined below.

NOTE: Before proceeding, the clutch must be installed on the engine crankshaft and the retaining bolt torqued to 45–48 ft-lbs (61–65 N•m).

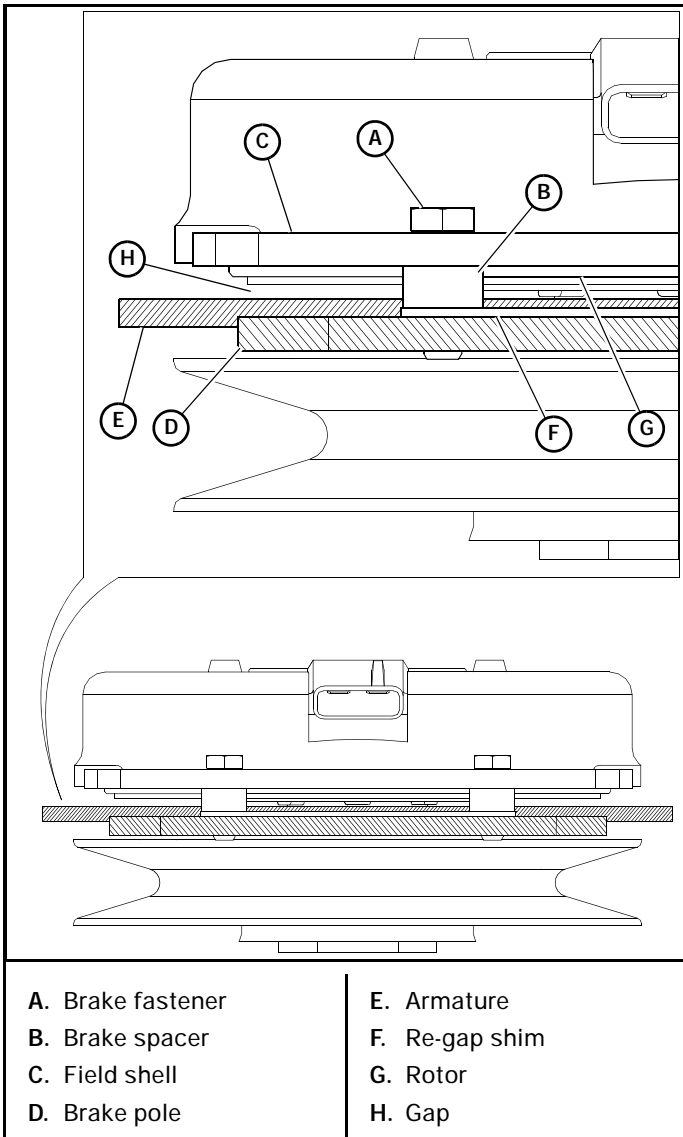

Figure 4-18

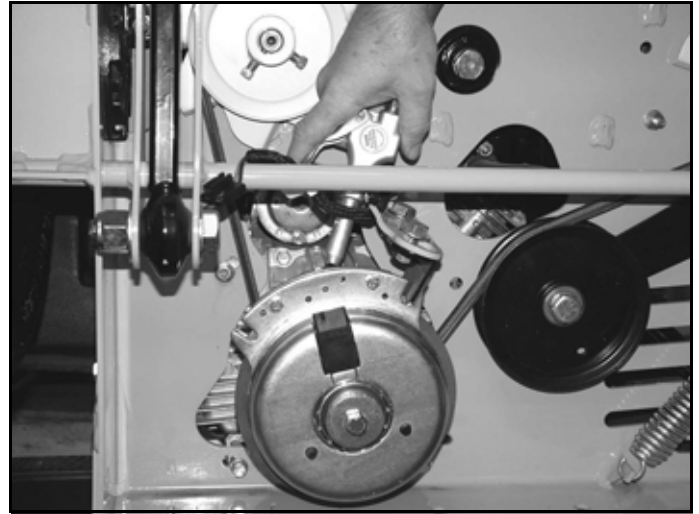

Figure 4-19

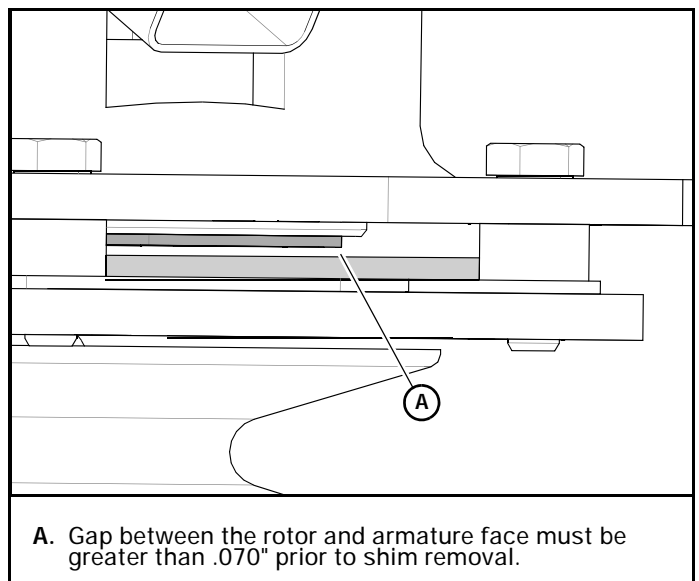

Figure 4-20

Procedure:

WARNING Always wear adequate eye protection when servicing the mower.

With engine off, key removed and clutch disengaged and using a pneumatic line, blow out any debris from under the brake pole and around the aluminum spacers. Figure 4-19

Check the air gap between rotor & armature with feeler gage. If the gap is less than .070", then follow the troubleshooting procedure outlined in Warner Electric P1177 installation troubleshooting guide available on Warner Electric's web site, www.warnerelectric.com. If the air gap is over .070", follow the procedure outlined below. Figure 4-20

WARNING Do not remove brake pole from field shell/armature. The brake pole tracks pole match with the clutch brake and need to continue to match after shim is removed to make sure of proper brake torque. Figure 4-18

1. Loosen both brake mounting bolts 1/2 to 1 full turn as shown in Figure 4-21.

2. Using needle nose pliers, or by hand, take hold of the tab and remove shim (do not discard shim until proper clutch function has been confirmed). Figure 4-22
3. Using a pneumatic line, blow out any debris from under the brake pole and around the aluminum spacers. Figure 4-19
4. Re-torque each bolt (M6 X 1) to 120 in.-lbs (13.5 N•m).
5. Using a .015" thick feeler gage, verify that a gap is present between the rotor and armature face on both

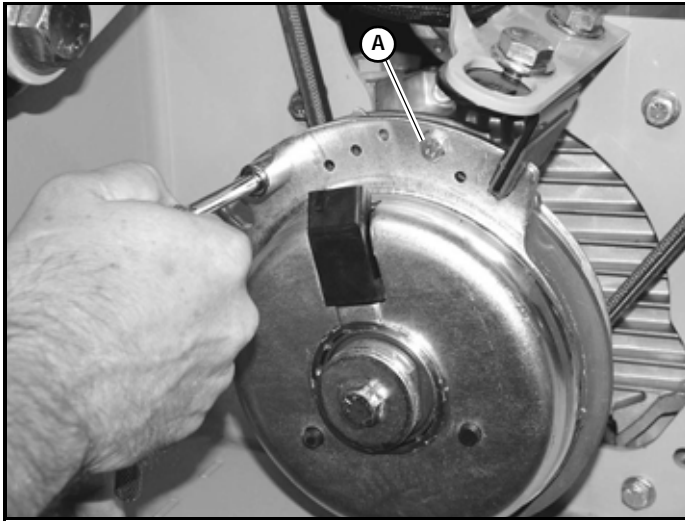

A. M6 x 1 bolt

Figure 4-21

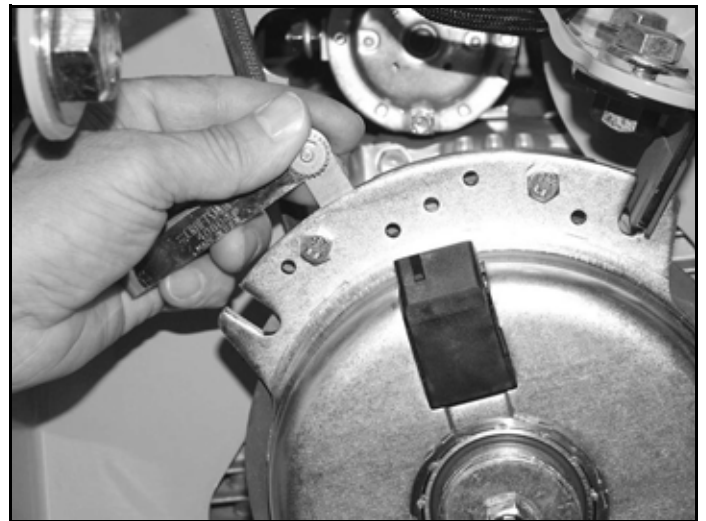

Figure 4-23

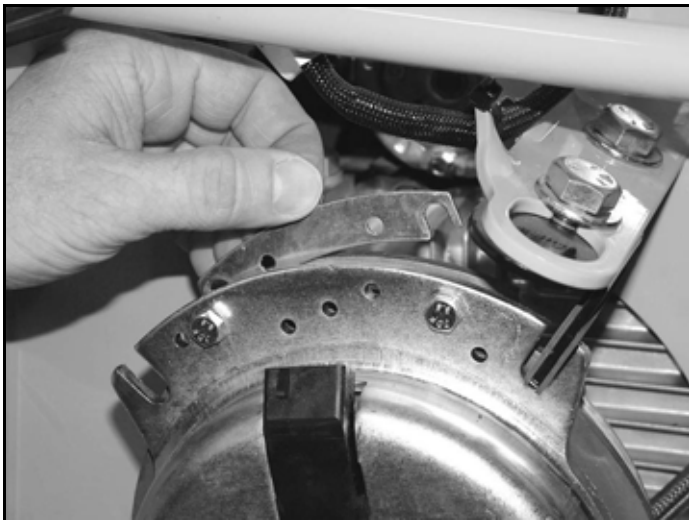

Figure 4-22

ends of the brake pole as shown. Figure 4-23 and Figure 4-24

- a. If the gap is less than .015" the clutch must be replaced.
- b. If sufficient gap is present, then proceed to safety check outlined below.



Figure 4-24

Perform Safety Check:

⚠ WARNING ⚠	<p>Observe deck operation from the operator's seat.</p>
--------------------	---

1. Start the engine and the deck should not be engaged with the PTO switch "off" and clutch de-energized. Engage and disengage the PTO switch to ensure the proper function of the clutch.
2. If clutch still does not engage, then follow the troubleshooting procedure outlined in Warner Electric P1177 installation troubleshooting guide available on Warner Electric's web site, www.warnerelectric.com and consult owner's manual.

Tires

It is important for level mowing that the tires have the same amount of air pressure. The recommended pressures are:

Drive wheels 8–12 psi (55–83 KPa)

Front wheels 8–12 psi (55–83 KPa)

If you wish to use non-pneumatic tires on your Hustler® mower, the tire must be a Hustler® approved tire. Warranty claims will be denied on any mower equipped with unapproved non-pneumatic tires.

Tapered Wheel Bearing Replacement

Disassembly:

1. Raise the front of the mower enough to remove the wheel assembly.
2. Place mower securely on jack stands and do not allow the mower to move. Chock the drive wheels.

WARNING	<ul style="list-style-type: none"> • Use only certified jack stands. Use only appropriate jack stands, with a minimum weight rating of 2000 pounds (907 kg) to block the unit up. • Use in pairs only. • Follow the instructions supplied with the jack stands.

3. Remove the wheel from the fork by removing the axle bolt, flat washers, and lock nut. Figure 4-25

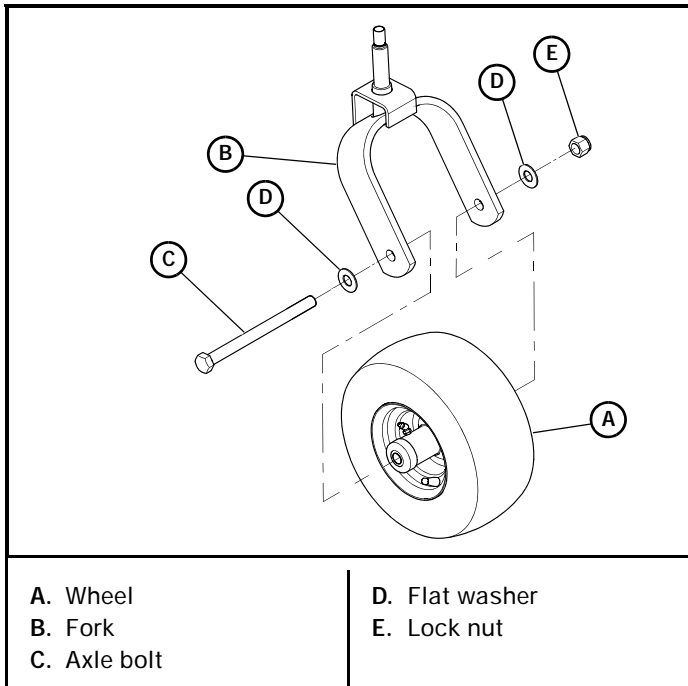

Figure 4-25

4. Remove the dust caps and bushings from the wheel housing. Retain these parts. Figure 4-26
5. Remove and discard the seals. Figure 4-26

6. Remove and discard the tapered roller bearings and outer bearing races. Figure 4-26

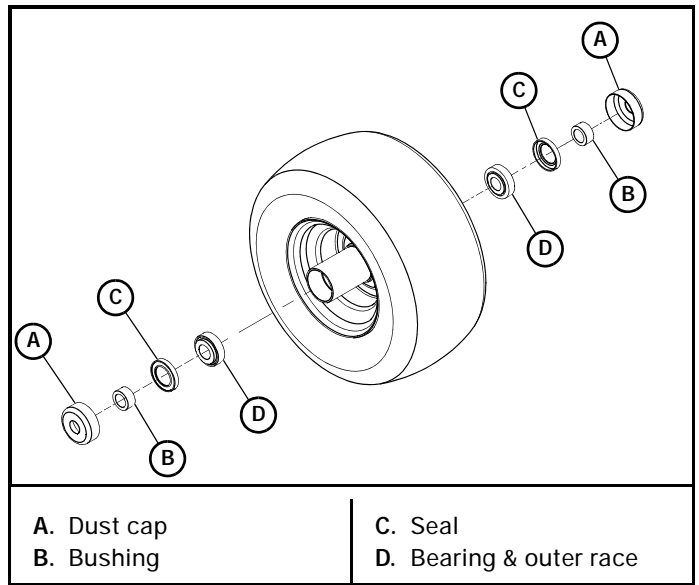

Figure 4-26

7. To prevent contamination of the new tapered roller bearings remove the existing grease from the wheel housing.

Assembly

1. Press the new outer bearing races into the wheel housing until they are fully seated against the housing shoulder. Figure 4-27

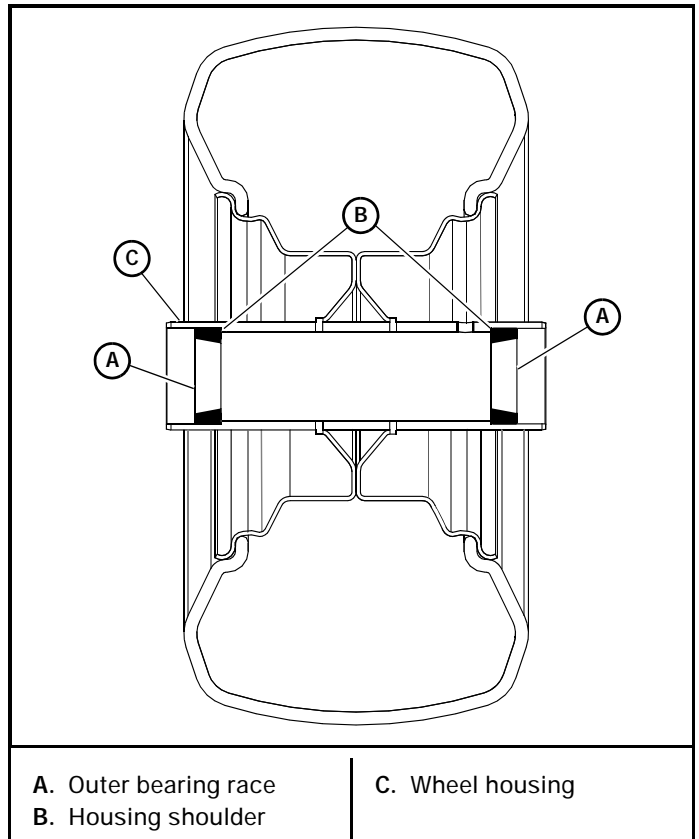

Figure 4-27

2. Thoroughly pack the tapered roller bearings with multi-purpose grease.
3. Insert the new tapered roller bearings into the outer bearing race. Figure 4-28
4. Insert the new seals into the wheel housing. Make sure that the flat side of the seal is flush with the outside edge of the wheel housing. Figure 4-28

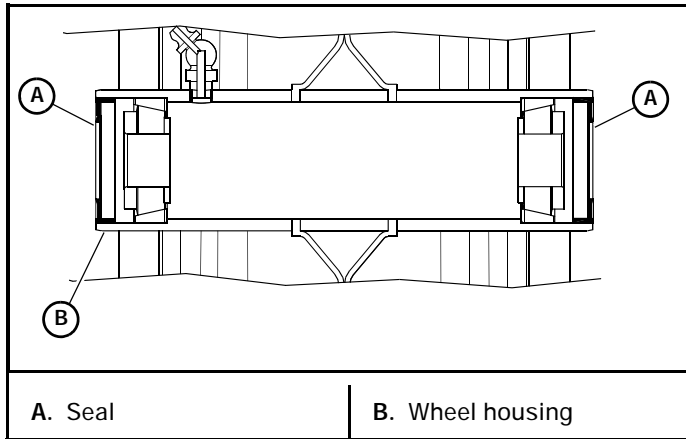

Figure 4-28

5. Insert the bushings through the seal openings and push them in until they contact the tapered roller bearings. Figure 4-29
6. Push the dust caps onto the wheel housing. Figure 4-29
7. Slide the wheel assembly between the caster fork legs and assemble to the fork using the axle bolt, flat washers, and lock nut. Figure 4-30

NOTE: Make sure the head of the axle bolt is on the same side as the valve stem.

8. Screw the lock nut onto the axle bolt and tighten. Then, back the nut off until the wheel rotates freely.
9. Using a grease gun, insert multi-purpose grease into the wheel housing until grease begins to seep from the dust caps.

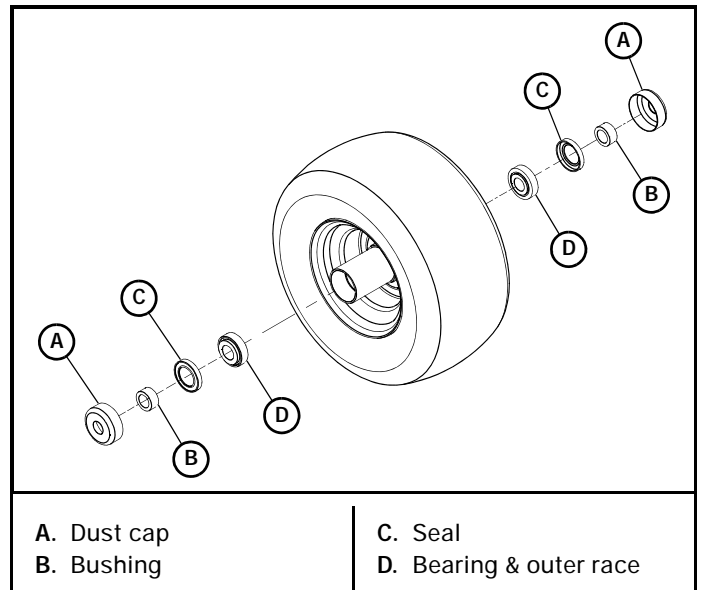

Figure 4-29

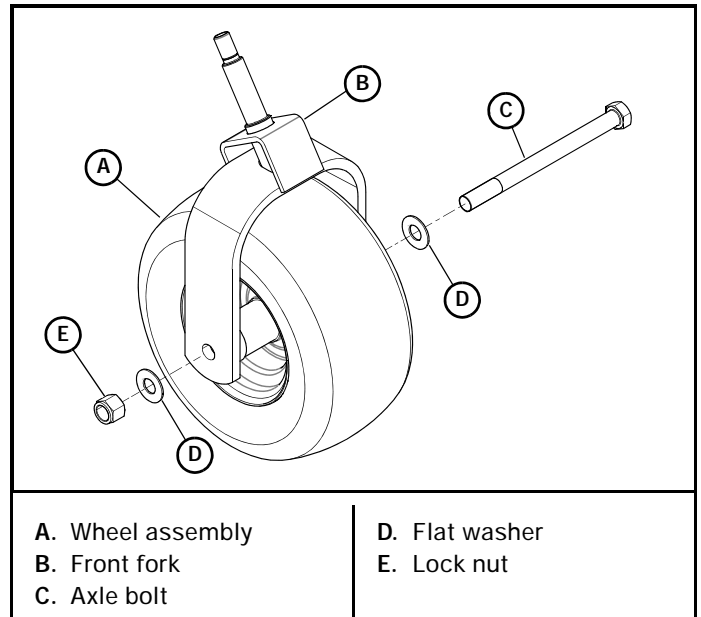

Figure 4-30

ENGINE MAINTENANCE

General Engine Maintenance

Detailed instructions and recommendations for break-in and regular maintenance are specified in the *Engine Owner's Manual*. Please refer to this manual for engine servicing, lubricating oil levels with quality and viscosity recommendations, bolt torques, etc. The engine warranty is backed by the engine manufacturer. Special attention should be paid to applicable data which will not be duplicated here.

Engine Oil and Filter

WARNING	If the engine has been running and is up to operating temperature, allow the engine to cool before changing the oil. Engine and engine oil will be very hot, so be very careful when changing oil and wear the appropriate protective gear to avoid being burned or exposed to engine oil.
----------------	--

Check engine oil daily and after every 4 hours of operation. Machine must be setting level when checking oil. Refer to engine manual and maintenance schedule for oil recommendation and capacities. Hustler® Motor Oil is recommended.

Change the engine oil and filter after the first 200 hours of operation and every 200 hours of operation after that. If mower is being operated in extremely dirty conditions, then it is recommended oil be changed more frequently. **IMPORTANT:** When removing the oil filter take precautions to minimize oil spillage on the exhaust system.

The engine oil filter is located behind the access cover behind the seat. Figure 5-1

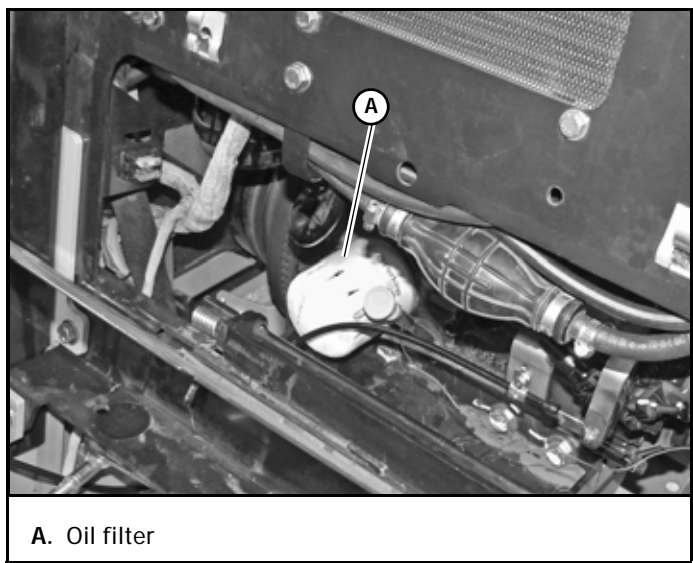

Figure 5-1

Engine Air Filter

Perform engine air filter maintenance per the *Maintenance Schedule* shown elsewhere in this manual.

A specially designed dry filter is standard equipment on these mowers and supplies clean combustion air to the engine. Figure 5-2

These mowers are equipped with a safety filter. The filter element slides over the safety filter. Figure 5-3

The safety filter does not require servicing unless it becomes contaminated with dirt or moisture.

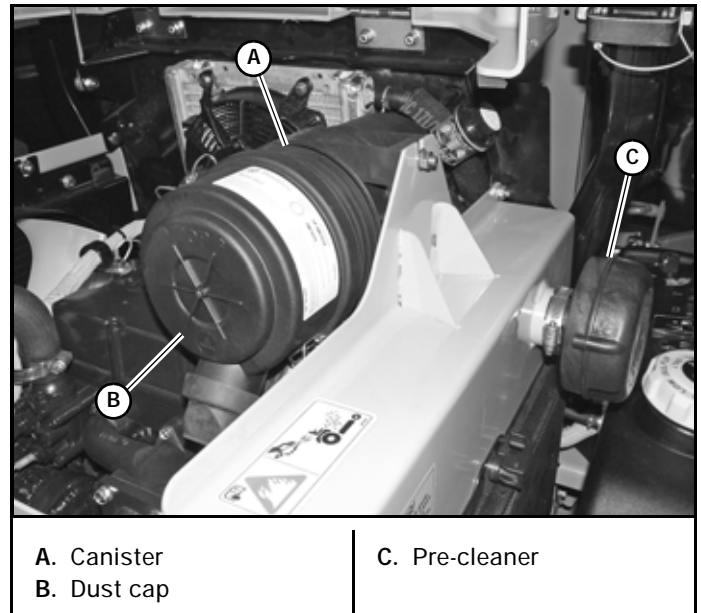

Figure 5-2

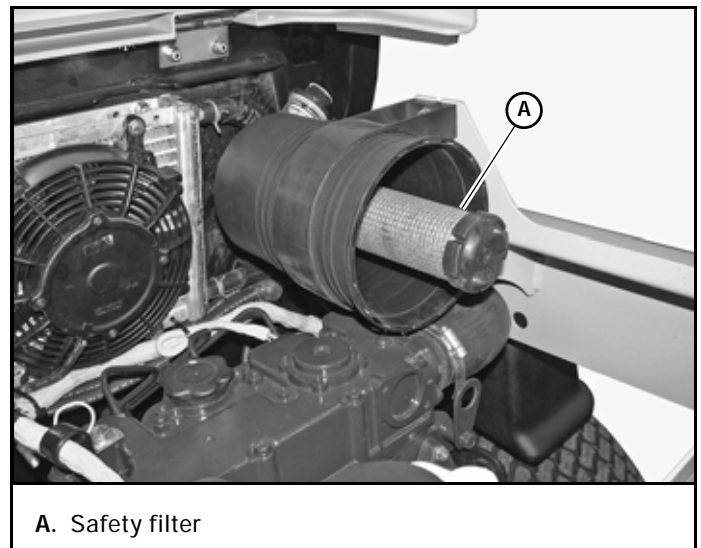

Figure 5-3

Recommended service procedure

1. Release clamps and remove element. Clean the canister with a damp cloth.

2. Before installing a new element, inspect it by placing a bright light inside and rotating the element slowly, looking for any holes or tears in the paper. Also check gaskets for cuts or tears. Do not attempt to use a damaged element which will allow abrasive particles to enter the engine.
3. Reinstall the dust cap. Make sure it seals all the way around the air cleaner body, then tighten the clamps.
4. Check all fittings and clamps periodically for tightness and inspect hoses for holes or cracks.
5. Periodically check the intake hose for signs of ingested dust. Locate and repair the source of ingested dirt.
6. Never operate the machine without an air filter installed.

Overservicing

Overservicing occurs when an air filter element is removed for cleaning or replacement before it is necessary. Each time the filter is removed a small amount of dirt and dust could fall in the intake system. This accumulated dirt can cause a dusted engine. It only takes a few grams of ingested dirt over the normal service life of an engine to cause a dusted engine.

Do not clean the element, replace with a new element only. Cleaning used air filter elements, through improper cleaning procedures, can get dust on the inside of the filter causing dirt ingestion and engine failure.

It is important to note that whenever an air filter element is cleaned by **any method**, the person or company performing the cleaning assumes responsibility for the integrity of the filter from then on. **The warranty for air filters expires upon cleaning or servicing in any manner because the condition of the filter after servicing is completely out of the filter manufacturer's control. Therefore, on a dust ingested engine failure, there will be no warranty consideration if the air filter element has been cleaned or serviced in any manner.**

A partially dirty air filter element works better than a new element. A dirty filter element is not bad for the engine unless it restricts the air flow too much and engine performance is affected. The media in the filter must be

porous to allow air to pass through it. When dirty air passes through the filter, the dirt plugs some of the holes in the media and acts as part of the filter media. When the next round of dirt enters, the first dirt layer helps filter out even smaller particles making the filter more efficient at stopping dirt from entering the engine. This is referred to as barrier filtration.

At some point the filter media will become too clogged to allow air to pass.

The mowing conditions will determine the frequency of air filter element changing.

Air restriction indicator

These units have an air restriction indicator installed in the air cleaner. Figure 5-4

Replace the element whenever the restriction indicator reaches the change filter red line. Check the indicator daily and replace element as needed or annually whichever occurs first.

Reset the indicator by pushing in on the yellow button after each element change. Figure 5-4

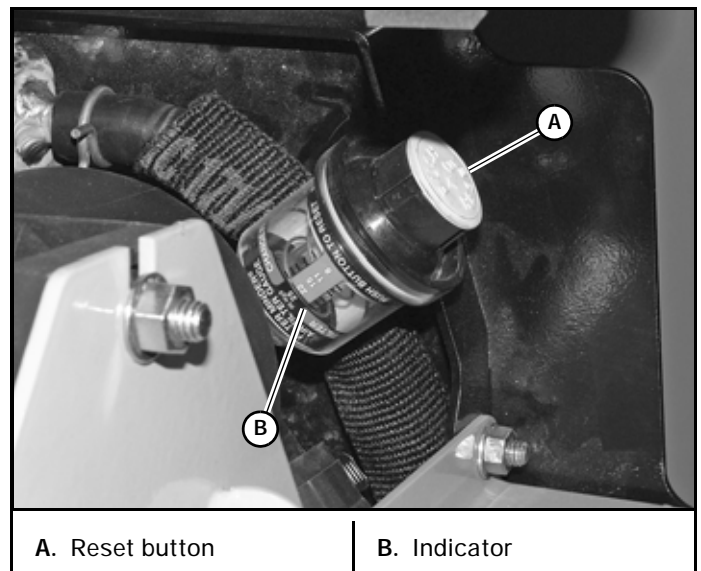

A. Reset button

B. Indicator

Figure 5-4

Engine RPM Settings

The engine rpm's are set at the factory for maximum mowing efficiency. Occasionally it may be necessary to check and adjust the settings. The high idle speeds, with no load, should be set as follows:

Perkins Model 403J-11	
ENGINE SPEED	
MODEL NO. ENDING WITH:	HIGH IDLE
MODEL NO. WITHOUT EXTENSION	3000 RPM

NOTE: Model numbers may or may not end with an extension after the number. There are several different extensions that may be shown; i.e. EX or CE.

Example: 922222 (no extension)

922222 EX

922222 CE

922222 US

DECK ADJUSTMENTS

Deck Leveling

Leveling the deck must be done in the following manner and order:

1. Check tire pressures to make certain they are properly inflated before starting to level deck. The recommended pressures are as follows:
 Drive wheels 8-12 psi (55-83 KPa)
 Gauge wheels 8-12 psi (55-83 KPa)

WARNING	<p>Stop engine. Make sure deck clutch switch is in the down (OFF) position. Place control levers in the brake position before leaving machine.</p>
----------------	---

2. Park the unit on a flat surface.
3. **Side Discharge Deck (Figure 6-1)** – Place 3" (76.2mm) high deck support blocks (two stacked 2" x 4" blocks can be used to create a 3" (76.2mm) high support at the four corners of the deck marked with the locator triangle as shown.

NOTE: The back of the deck will automatically be set 1/4" (6.35 mm) higher.

Rear Discharge Decks (Figure 6-2) – Place two 3.75" (95.3mm) high deck support blocks (two stacked 2" x 4" blocks and one 1" x 4" can be used to create a 3.75" [95.3mm] high support) at the front of the deck as shown. Place two 3" high deck support blocks (two stacked 2" x 4" blocks can be used to create a 3" [76.2mm] high support) at the sides of the deck as shown.

4. **Side Discharge Deck** – Place the height stop in the 3" (76.2mm) hole, with the pin side of the height adjusting stop against the stop handle.

Rear Discharge Decks (all) – Place the height stop in the 3.25" (82.6mm) hole, with the plate side of the height adjusting stop against the stop handle.

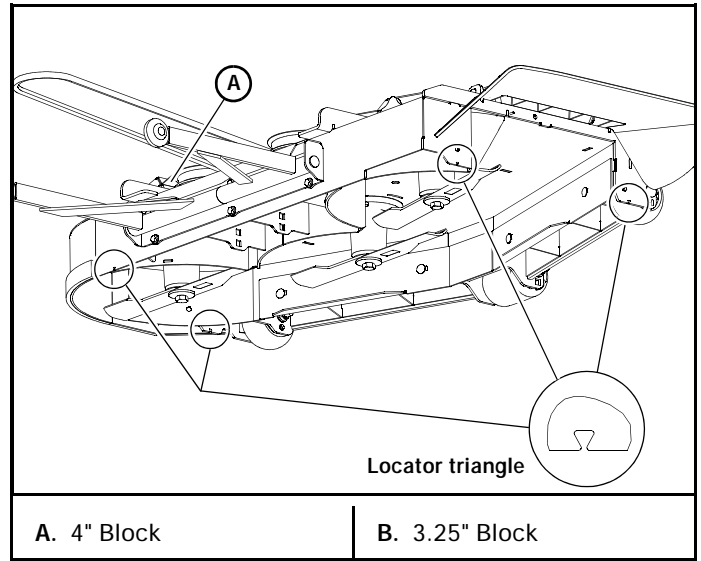

Figure 6-1

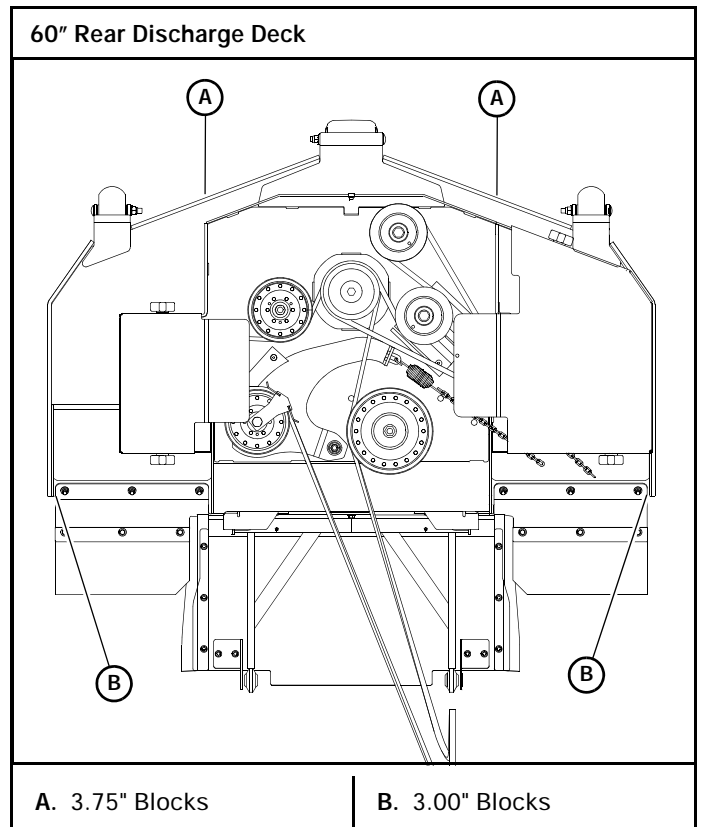

Figure 6-2

5. Clamp the height adjusting stop against the stop handle. This will assure that the height will not move during the setting process. Otherwise, spring pressure from the deck lift springs will tend to pull the stop away from the handle. Figure 6-3
6. Loosen all nuts on the deck lift threaded rods, and the hardware on the height indicator bar (on the right front), until **all** the deck lift chains are loose, **and** the

deck is sitting tightly on all four blocks. Figure 6-4, Figure 6-5 & Figure 6-8

7. Loosen the two nuts on the front of height indicator so that the foot pedal is free. Figure 6-4
8. Start the leveling process on the **left front** of the mower.
9. Set the amount of threads protruding on the deck lift rod from the lift block at approximately 1" (25.4 mm) (left & right side). Figure 6-5
10. Jam both nuts against the block.

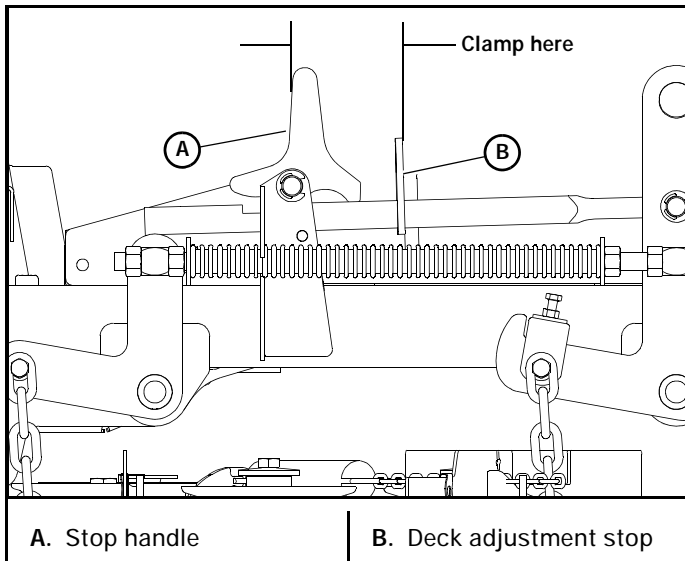

Figure 6-3

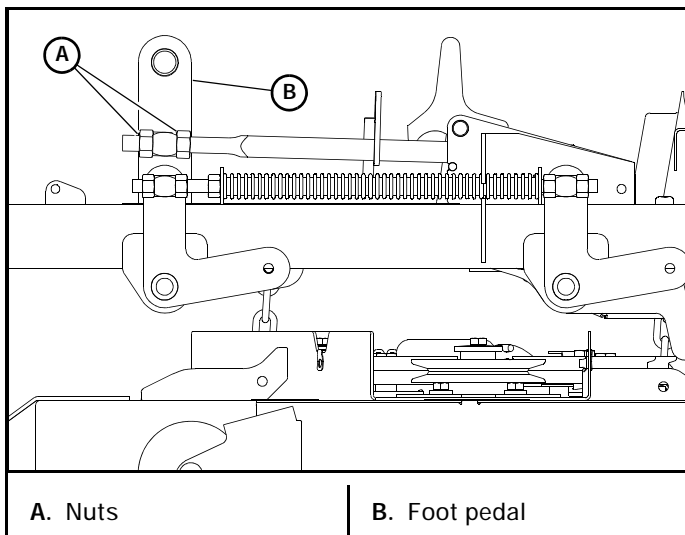

Figure 6-4

11. Push or pull on the deck lift foot pedal until the chain on the left front just becomes tight, making sure that the deck stays tight against the block.
12. While keeping the chain tight, tighten the nuts against the deck lift block on the height indicator rod, just enough to carry most of the deck weight on that side — the block should be able to move with only a slight drag. Figure 6-5
13. Jam nuts tightly together against the deck lift block.

14. Go to the **right front** of the mower.
15. Loosen the 5/16" jam nut on the adjuster lift chain, and back the adjuster bolt out to allow the adjuster to move up and down freely. Figure 6-6
16. Tighten the adjuster bolt until the chain just becomes tight. Then tighten just enough to carry the weight of the front of the deck on that side—to check, move the blocks back and forth; they should move with a slight drag. Figure 6-6
17. Tighten the adjuster bolt jam nut to prevent the adjuster bolt from moving. Figure 6-6
18. Tighten the hardware holding the chain and adjuster onto the deck lift arm. Figure 6-6

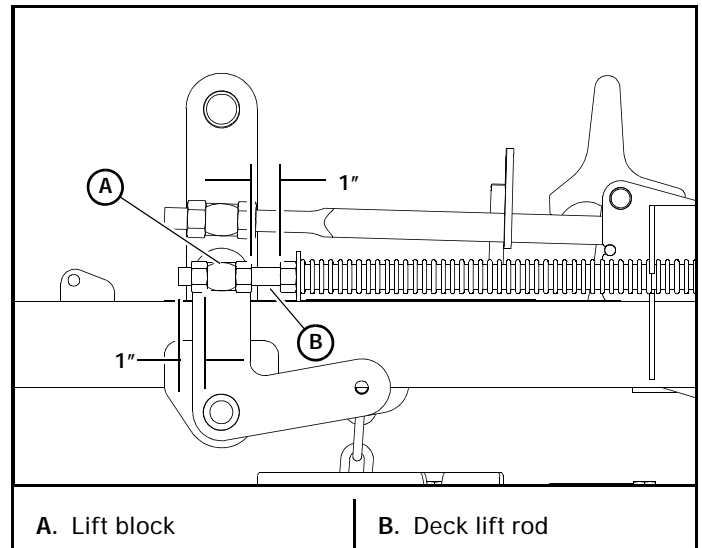

Figure 6-5

19. Go to the **right rear** of the mower.
20. Make sure that there is still slack in the chain. If not, loosen the two nuts on the block holding the threaded rod until there is slack in the deck lift chain.
21. Tighten the appropriate nut until the chain just becomes tight, and carries most of the deck weight. Check by moving the block—it should move with a slight drag. Figure 6-7
22. Tighten the other nut on the opposite side of the block, and jam them tightly together against the block.
23. Go to the **left rear** of the mower.
24. Make sure that there is still slack in the chain. If not, loosen the two nuts on the block holding the threaded rod until there is slack in the deck lift chain. Figure 6-8
25. Tighten the appropriate nut until the chain just becomes tight, and carries most of the deck weight. Check by moving the block—it should move with a slight drag. Figure 6-8
26. Tighten the other nut on the opposite side of the block, and jam them tightly together against the block.
27. Compress the deck lift assist springs so that there is 1" (25.4 mm) of space between the front nut on the

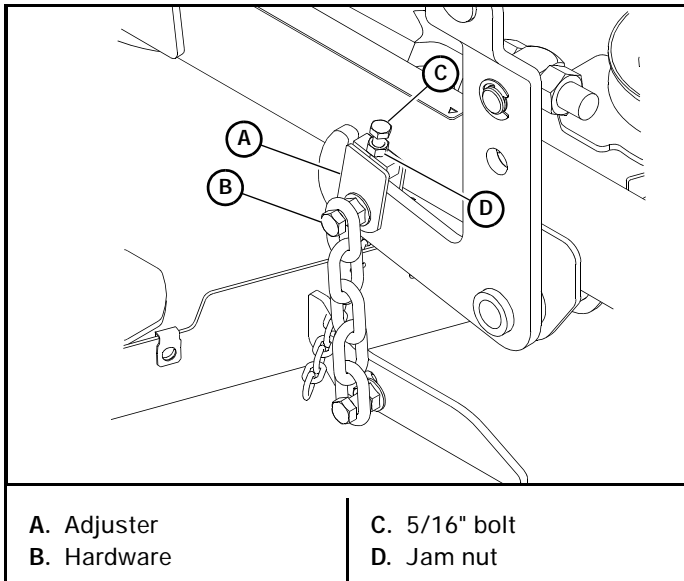

Figure 6-6

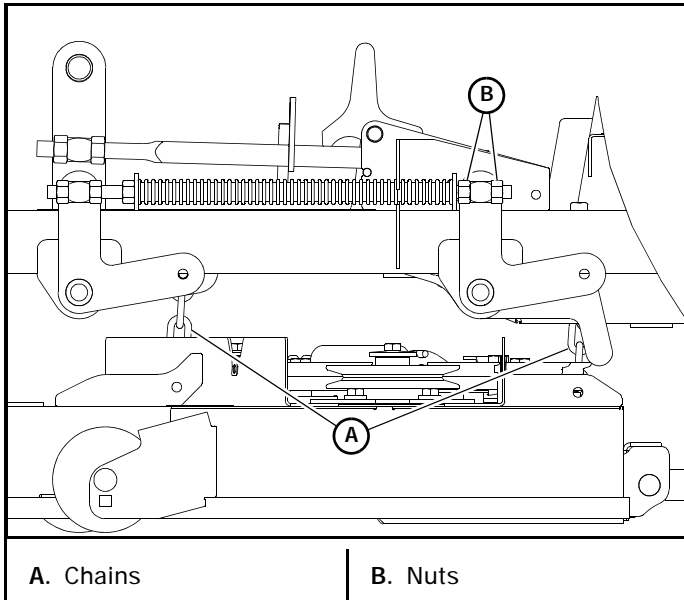

Figure 6-7

spring and the rear nut on the deck lift block. Typical both sides. Figure 6-5

28. When completed, all chains will be tight, and deck cutting height will be set to the deck height indicator.

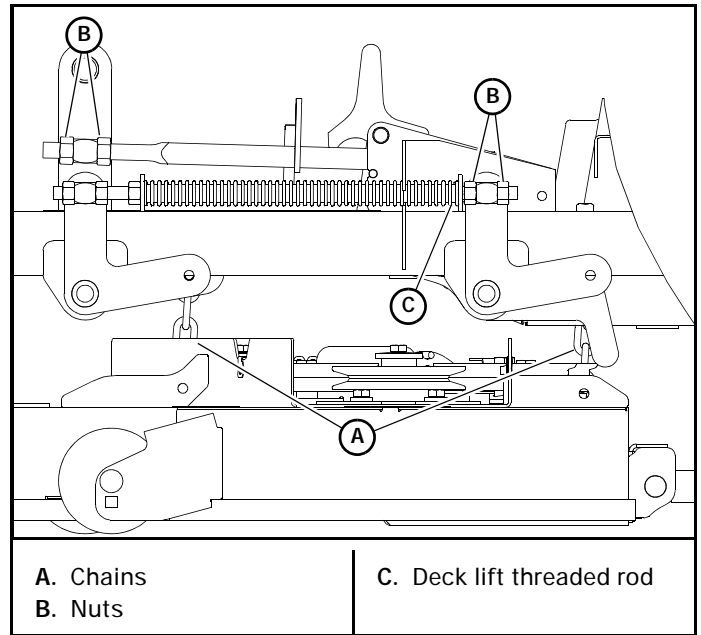

Figure 6-8

Blades

Mower blade maintenance

IMPORTANT: Refer to the *Safety* section of this manual for blade handling safety information.

Refer to the *Mower Blade Replacement* section for blade removal and installation.



Mower blades are sharp and can cut. Wrap the blade(s) or wear gloves and use extra caution when servicing them.

Check the mower blades daily, they are the key to power efficiency and well groomed turf. Keep the blades sharp. A dull blade will tear rather than cut the grass, leaving a brown ragged top on the grass within a few hours. A dull blade also requires more power from the engine.

Replace any blade which is bent, cracked or broken.



Always check for blade damage:

- if mower strikes a rock, branch or other foreign object during mowing!
- or if an abnormal vibration occurs while operating.

Make all necessary repairs before resuming operation.

Sharpen the blades following the pattern shown. Touch-up sharpening can be done with a file. Figure 6-9

After grinding the blades, check for balance. Blade balancing can be done by placing the blade on an inverted line punch or 5/8" bolt. A commercial balancing tool is also available through most hardware supply stores.

The blade should not lean or tilt. When spinning the blade slowly it should not wobble. Balance the blade before reinstalling.

Lay the blade on a flat surface and check for distortion. Replace any distorted blade. Figure 6-10 & Figure 6-11

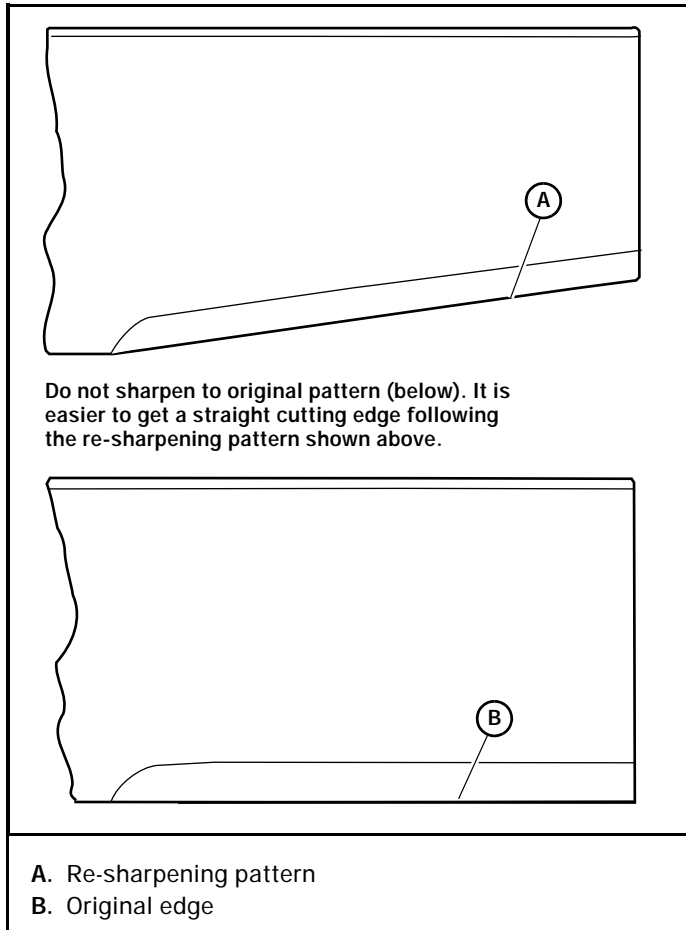

Figure 6-9

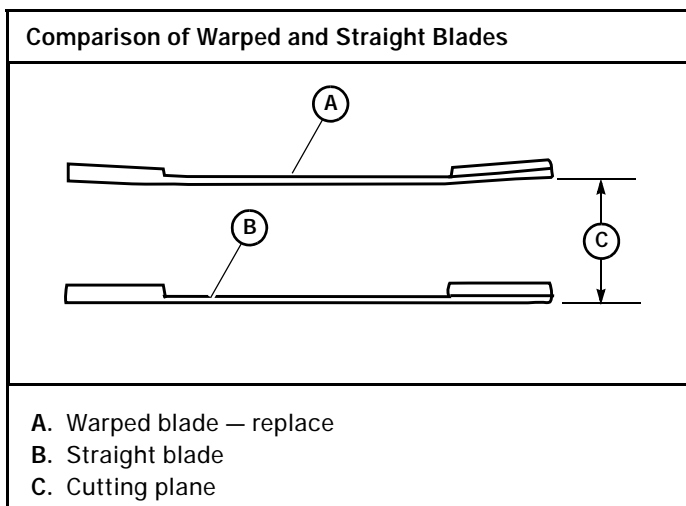

Figure 6-10

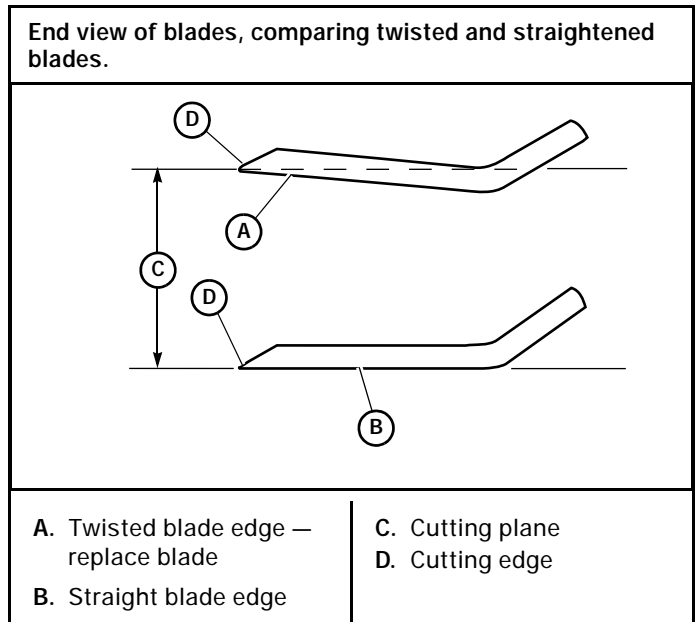
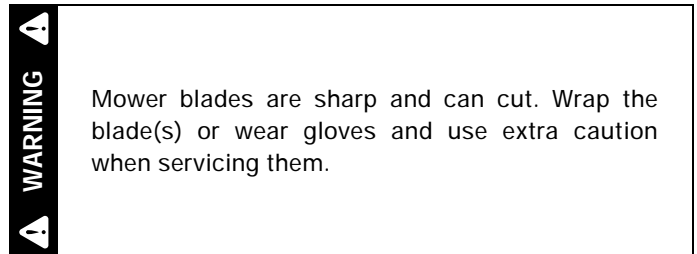

Figure 6-11

Mower blade removal

IMPORTANT: Refer to the *Safety* section of this manual for blade handling safety information.



A 15/16" wrench is required to remove the 5/8" cap screw holding the blade to the spindle shaft. **NOTE:** A blade holding tool (P/N 381442) is available from Hustler® Turf Equipment. It is designed to prevent the blades from rotating when they are being removed or installed on the spindle. Contact your Hustler® Dealer for more information.

Do not re-use spindle bolts which have stripped, worn or undercut threads. Torque bolts on spindles to 118 ft-lbs (160.0 N•m) when reinstalling blades.

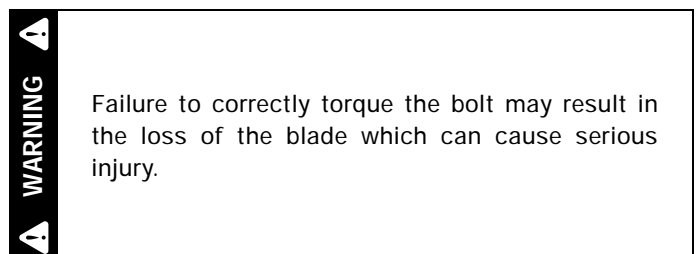

Properly compressed cup washers maintain the correct compression load on the blades. Replace the cup washers if they are cracked or flattened.

IMPORTANT: The blade sail (curved part) must be pointing upward toward the inside of the deck to make sure of proper cutting.

When mounting blades, rotate them after installation to make sure blade tips do not touch each other or sides of the mower.

Belts

Inspect belts frequently for wear and serviceability. Replace a belt that shows signs of:

- severe cuts
- tears
- separation
- weather checking
- cracking
- burns caused by slipping.

Slight raveling of belt covering does not indicate failure, trim ravelings with a sharp knife.

Inspect the belt pulley grooves and flanges for wear. A new belt, or one in good condition, should never run against the bottom of the groove. Replace the pulley when this is the case, otherwise, the belt will lose power and slip excessively.

Never pry a belt to get it on a pulley as this will cut or damage the fibers of the belt covering.

Keep oil and grease away from belts, and never use belt dressings. Any of these will destroy the belt composition in a very short time.

Deck Belt Adjustment

Side Discharge Decks

The spindle belt tension remains constant by means of a tension idler and spring. The spring tension should be such that the belt does not slip under normal operating load conditions, assuming the belt is not excessively worn or damaged. As the belt stretches and wears in, adjustment may become necessary. To increase belt tension, move the

spring chain one (or more) link(s) at the anchor point on the deck frame. Figure 6-12 & Figure 6-13

IMPORTANT: Do not over tension the spring to compensate for a badly worn belt or pulley.

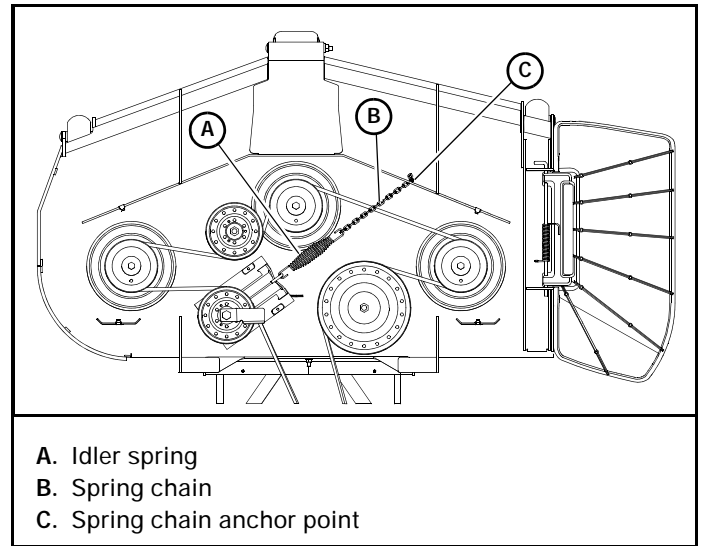

Figure 6-12

Rear Discharge Decks

There are two deck drive belts on these decks. The belt tension remains constant by means of a tension idler and spring on each belt. The spring tension should be such that the belt does not slip under normal operating load conditions, assuming the belt is not excessively worn or damaged. As the belts stretch and wears in, adjustment may become necessary. Figure 6-13 & Figure 6-14

Tension adjustment for either belt is the same. To increase belt tension, move the spring chain one (or more) link(s) at the anchor point on the deck frame. Figure 6-13 & Figure 6-14

IMPORTANT: Do not over tension the spring to compensate for a badly worn belt or pulley.

60" Rear Discharge Decks

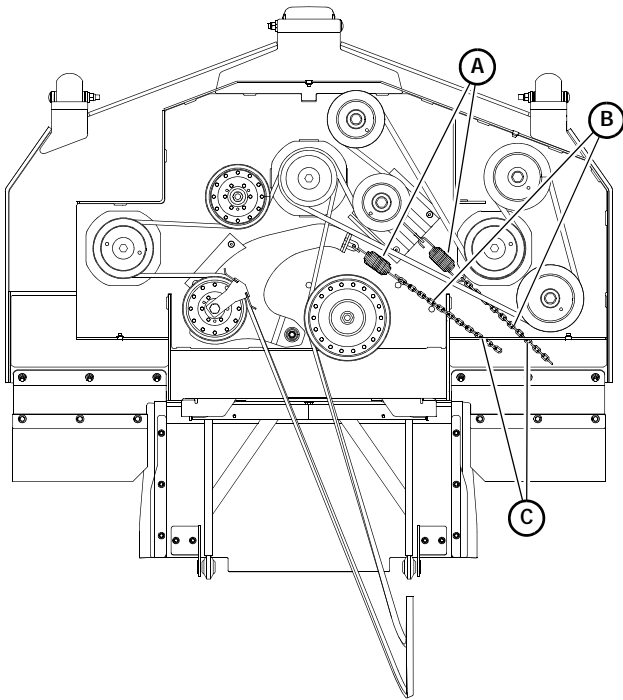

- A. Idler spring
- B. Spring chain
- C. Spring chain anchor point

Figure 6-13

72" Rear Discharge Decks

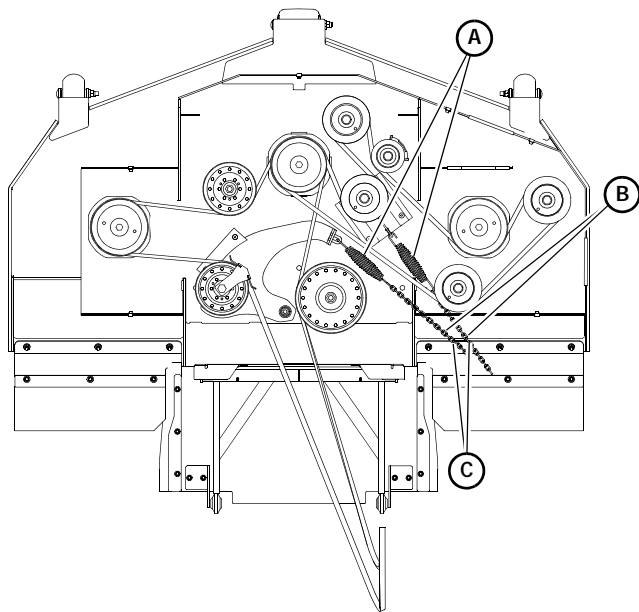

- A. Idler spring
- B. Spring chain
- C. Spring chain anchor point

Figure 6-14

Deck Belt Routing & Tensioning

Side Discharge Deck

NOTE: The following notes are the same for the three different decks shown.

- 1. Spring length after tensioning new belt. Measured from outside of hook to outside of hook with deck set at 3.25" (82.6 mm) cut height.
- 2. Route belt as shown.

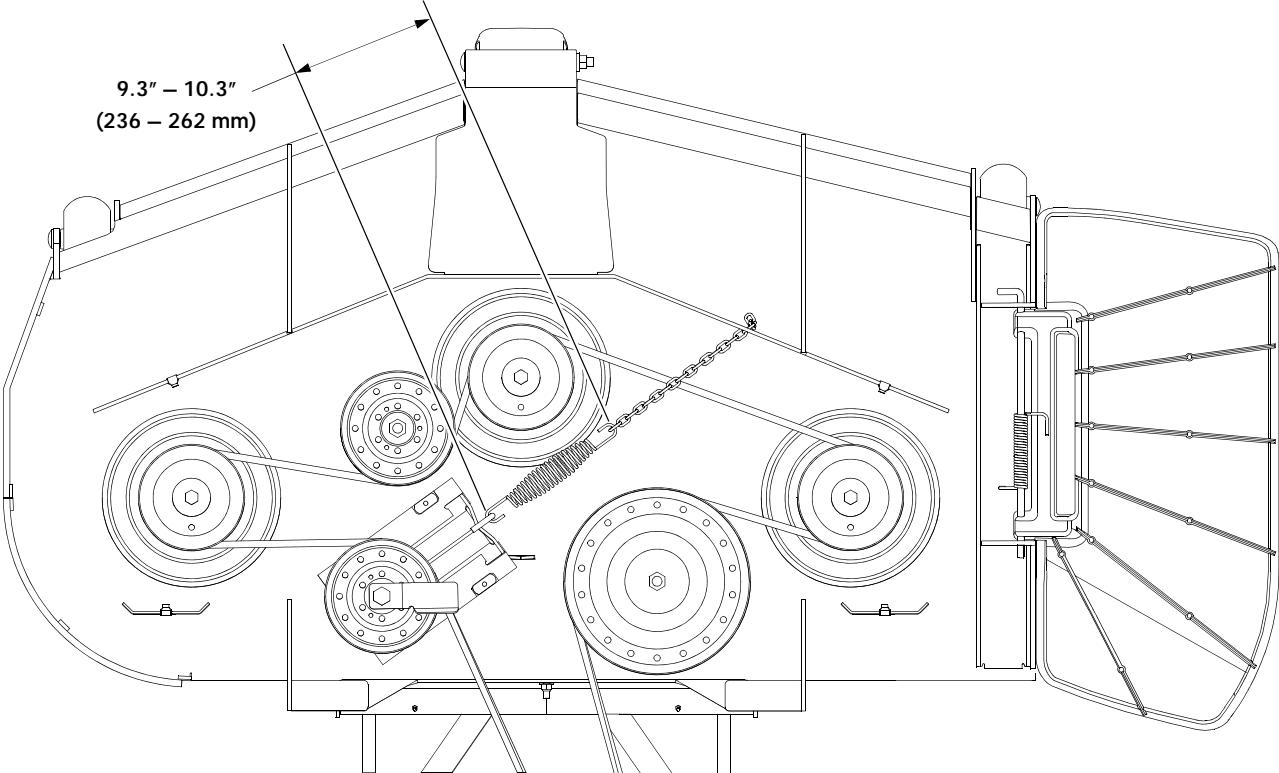

Figure 6-15

60" Rear Discharge Deck

1. Spring length after tensioning new belt. Measured from outside of hook to outside of hook with deck set at 3.25" (82.6 mm) cut height.
2. Route belt as shown.

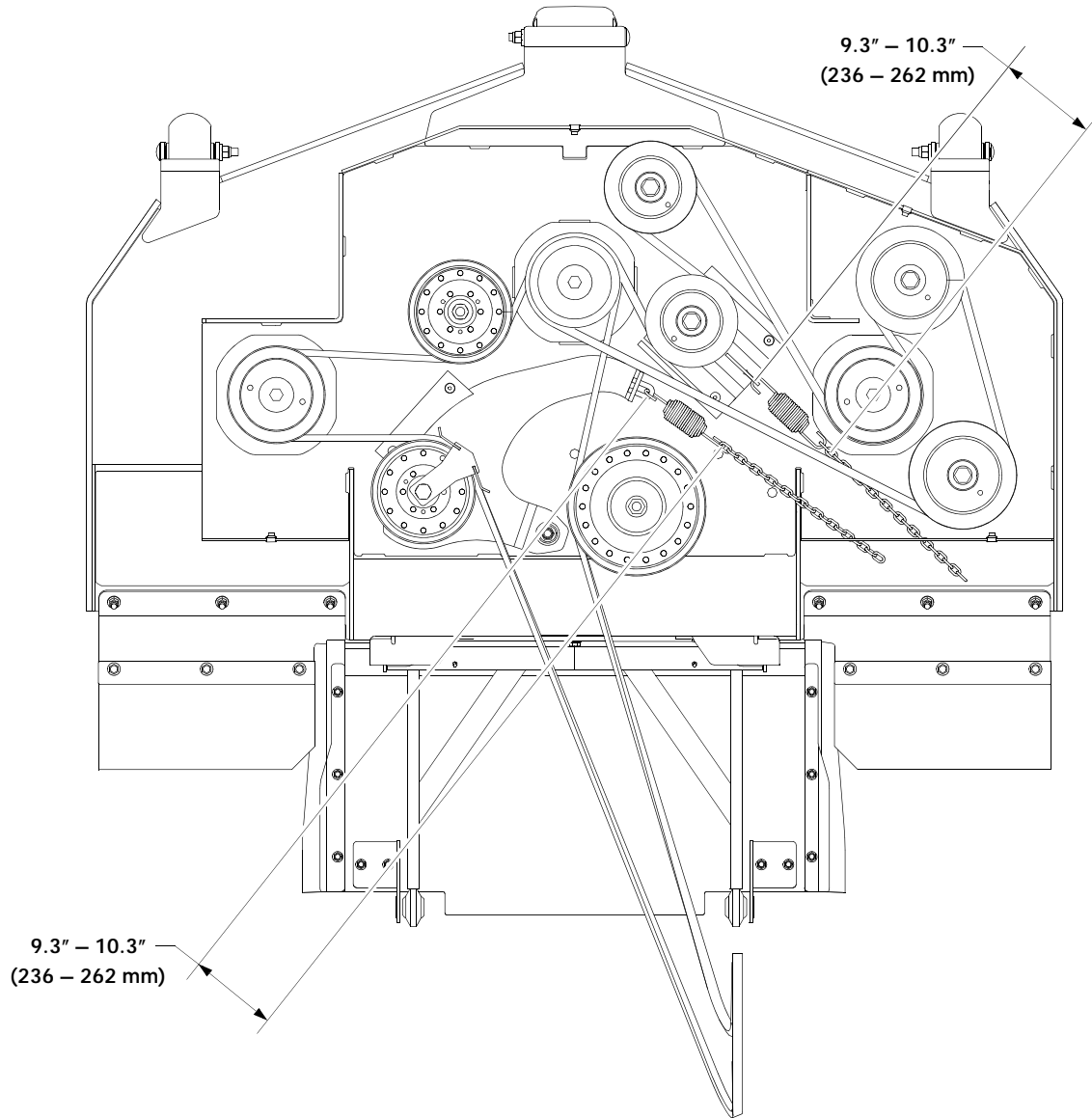

Figure 6-16

72" Rear Discharge Deck)

1. Spring length after tensioning new belt. Measured from outside of hook to outside of hook with deck set at 3.25" (82.6 mm) cut height.
2. Route belt as shown.

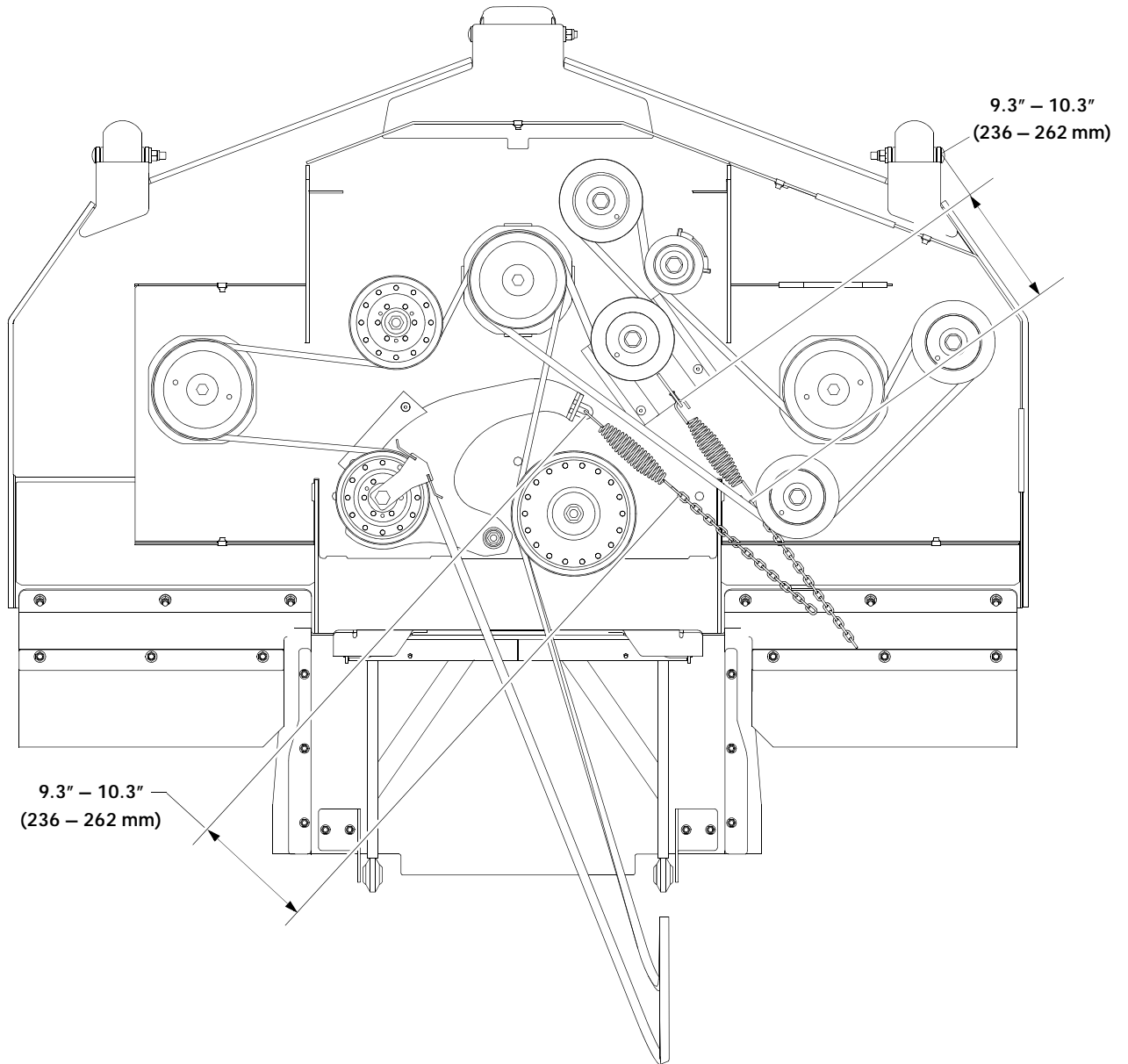

Figure 6-17

ELECTRICAL

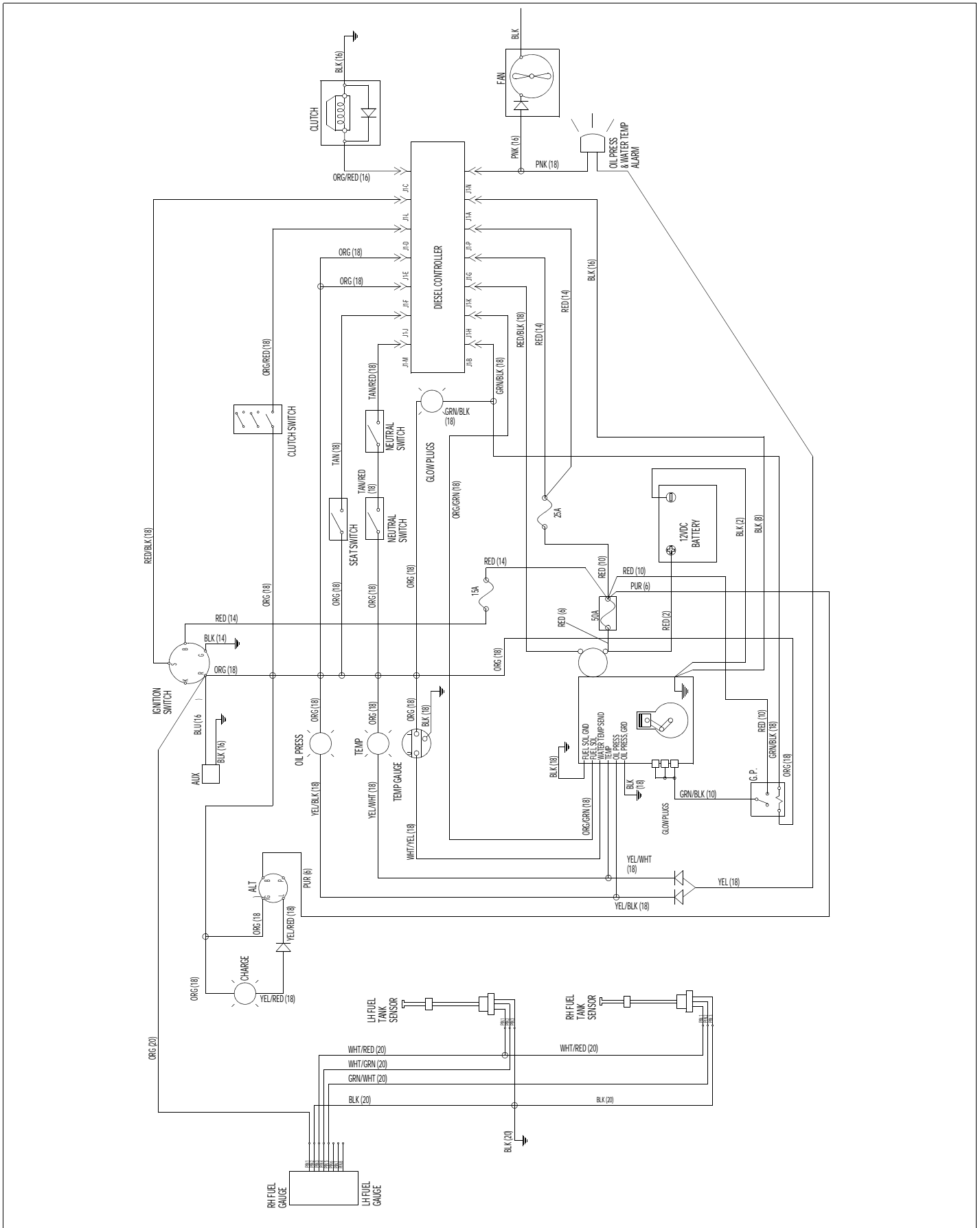

Figure 7-1

MAINTENANCE SCHEDULE

Maintenance Schedule Figure 8-1, Figure 8-2, Figure 8-3, Figure 8-4, Figure 8-5, Figure 8-6, Figure 8-7, Figure 8-8, & Figure 8-9			
SERVICE AT INTERVALS INDICATED	WEEKLY OR 50 HOURS	MONTHLY OR 100 HOURS	* ANNUALLY OR 500 HOURS
Verify safety start interlock system		Prior to each use	
Visually inspect unit for loose hardware and/or damaged parts		Prior to each use	
Visually inspect tires		Prior to each use	
Check oil level, engine (1) (4)		Prior to each use or every 4 hours	
Clean oil heat exchanger (8)		Prior to each use or every 4 hours	
Check radiator screen (8)		Prior to each use or every 4 hours	
Clean air intake screen (8)		Prior to each use or every 4 hours	
Check fuel level		Prior to each use	
Blades - sharpen & securely fastened		Prior to each use	
Discharge chute - securely in place & in lowest position		Prior to each use	
Rear discharge deck flaps and/or power unit deflector securely in place		Prior to each use	
Clean engine and pump compartment		Daily	
Check air cleaner service indicator (8)		Daily	
Replace engine air cleaner element (5) (10)		As needed	
Check battery connections	X		
Check tire pressure with a gauge	X		
Check hydraulic oil level	X		
Clean engine exterior (10)	X		
Grease deck pusher arms (8)		X	
Grease pump idler (8)		X	
Grease deck height pivots (8)		X	
Grease front wheel bearings (8)		X	
Check pump and deck belt tension and condition (6)		X	
Check fuel system (7)		X	
Check hydraulic lines		X	
Check fuel valve (7)		X	
Check fuel tank grommets (7)		X	
Tighten lug nuts on wheels (2)		X	
Change engine oil and filter (1) (4)		Every 200 hours	
Change fuel filter (7)			X
Clean or replace hydraulic fill cap			X
Change hydraulic filter & oil (3)			X
Grease deck spindle housings			X
Injection nozzle check			X
Check ROPS mounting hardware (9)			X
Cooling system circuit cleaning (8)			X

NOTES:

1. Initial engine oil change is after 200 hours of operation. Thereafter, change oil after every 200 hours operation. Change more often under dusty or dirty conditions and during hot weather periods. Hustler® Motor Oil is recommended.
2. Torque initially and after first 2 hours of operation.
3. Perform initial hydraulic oil and filter change after **50 hours** (one week) of operation. Thereafter, **change oil and filter annually or every 500 hours** whichever comes first. Hustler® Full Synthetic 20W50 Hydrostatic Transmission Oil is recommended.
4. Change engine oil filter per the engine manufacturer's recommendations. Refer to Engine Owner's Manual for recommendations and other maintenance items.

5. Service more often under dusty or dirty conditions. Use caution when servicing to prevent dust contamination in the engine. **Do not** clean filter element. Replace with a new one.
6. **Pump drive belt only - Inspect belt every 100 hours** and replace if worn or cracking is noticed. Check spring tension adjustment. Otherwise, **replace belt every 400 hours or 2 years** whichever comes first. Check and adjust spring tension after 50 hours of use as outlined in the *Hydraulic Pump Belt Adjustment* section of the General Service Manual (126936).
7. Check fuel system for any cracks or leaks including, but not limited to, fuel line hoses, fuel valve, vent line hoses, vent valve, vapor valve, carbon canister, and grommets. Replace as needed.
8. More often under dusty or dirty conditions and during hot weather.
9. Inspect ROPS after the first 20 hours of operation and then after every 500 hours of operation or yearly whichever comes first.
10. Refer to engine owner's manual for engine service information.

* After completing maintenance cycle (500 hours), repeat cycle.

Maintenance Locator Chart

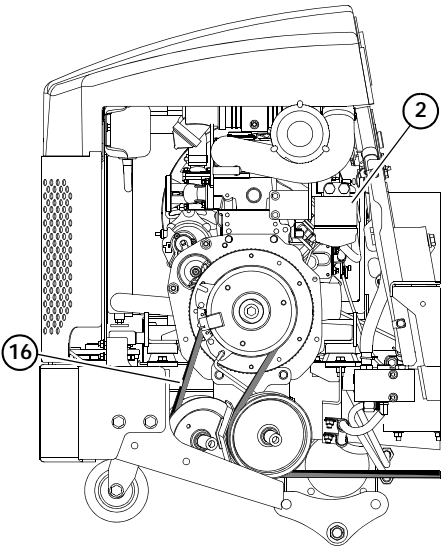
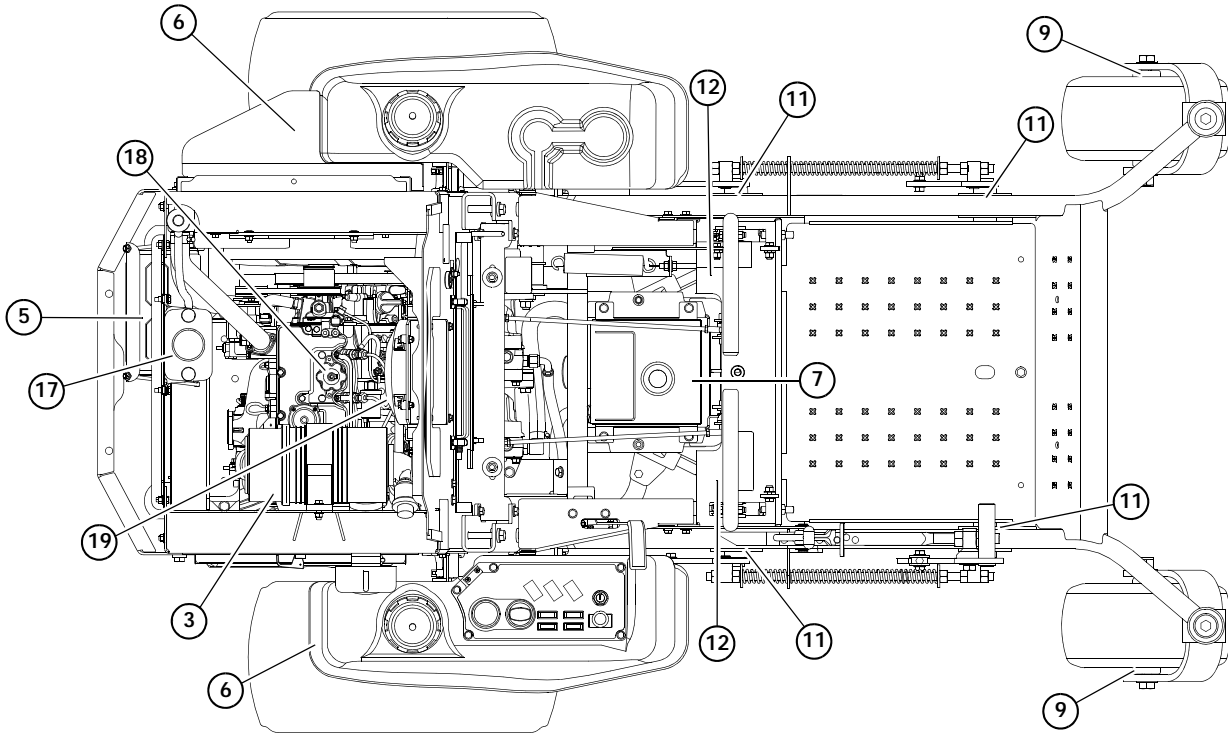

Figure 8-2

1. Engine Oil Dipstick
2. Fuel Filter
3. Engine Air Cleaner
4. Engine Oil Drain Plug
5. Battery
6. Fuel Tanks
7. Hydraulic Oil Reservoir
8. Hydraulic Oil Filter
9. Gauge Wheel Bearing Zerks (2)
10. Engine Oil Filter
11. Deck Height Pivot Zerks (4)
12. Park Brake Switch
13. Drive Tire
14. Pump Idler Zerk (1)
15. Pump Belt
16. Deck Drive Belt
17. Engine Coolant Fill
18. Engine Oil Fill
19. Hydraulic Oil Heat Exchanger
20. Deck Pusher Arm Zerks (2)
21. Deck Belt
22. Spindle Housing Zerks (3)
23. Blades (3)

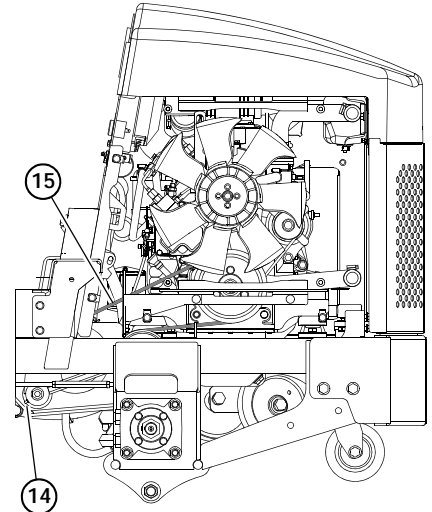

Figure 8-3

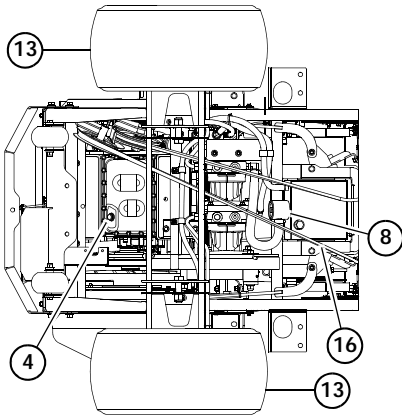

Figure 8-4

1. Engine Oil Dipstick
2. Fuel Filter
3. Engine Air Cleaner
4. Engine Oil Drain Plug
5. Battery
6. Fuel Tanks
7. Hydraulic Oil Reservoir
8. Hydraulic Oil Filter
9. Gauge Wheel Bearing Zerks (2)
10. Engine Oil Filter
11. Deck Height Pivot Zerks (4)
12. Park Brake Switch
13. Drive Tire
14. Pump Idler Zerk (1)
15. Pump Belt
16. Deck Drive Belt
17. Engine Coolant Fill
18. Engine Oil Fill
19. Hydraulic Oil Heat Exchanger
20. Deck Pusher Arm Zerks (2)
21. Deck Belt
22. Spindle Housing Zerks (3)
23. Blades (3)

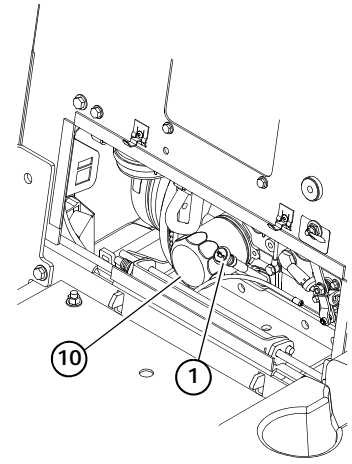
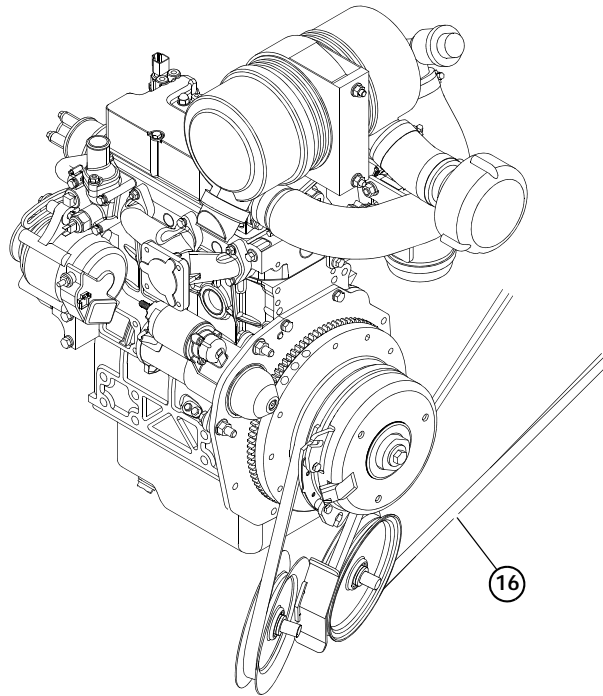
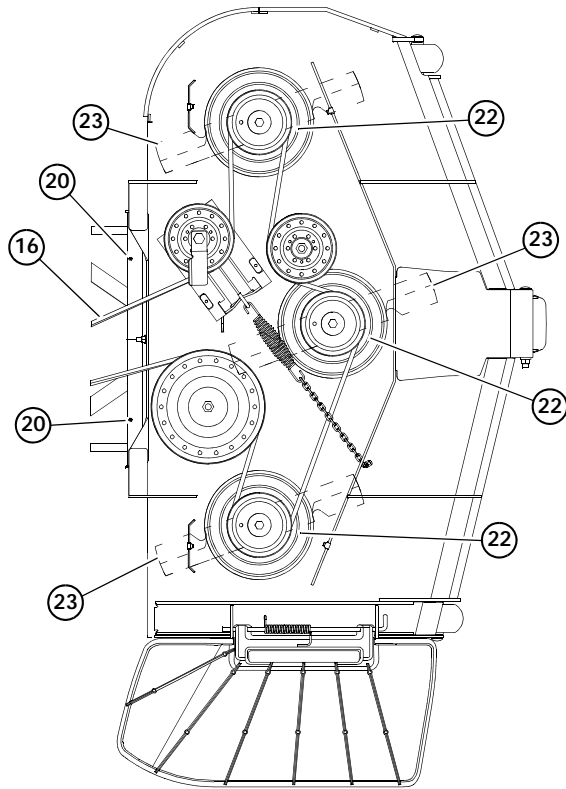

Figure 8-5

Figure 8-6



Side Discharge Deck



1. Engine Oil Dipstick
2. Fuel Filter
3. Engine Air Cleaner
4. Engine Oil Drain Plug
5. Battery
6. Fuel Tanks
7. Hydraulic Oil Reservoir
8. Hydraulic Oil Filter
9. Gauge Wheel Bearing Zerk (2)
10. Engine Oil Filter
11. Deck Height Pivot Zerk (4)
12. Park Brake Switch
13. Drive Tire
14. Pump Idler Zerk (1)
15. Pump Belt
16. Deck Drive Belt
17. Engine Coolant Fill
18. Engine Oil Fill
19. Hydraulic Oil Heat Exchanger
20. Deck Pusher Arm Zerk (2)
21. Deck Belt
22. Spindle Housing Zerk (3)
23. Blades (3)

Figure 8-7

60" Rear Discharge Deck

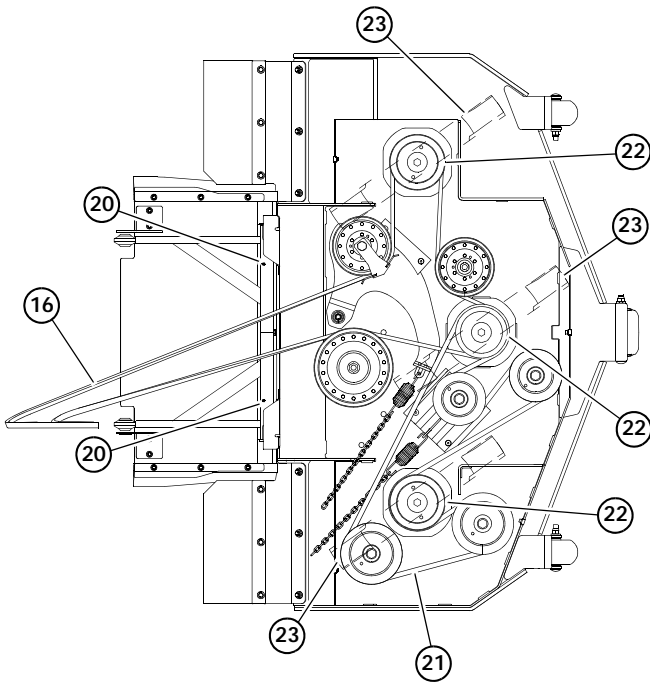

Figure 8-8

72" Rear Discharge Deck

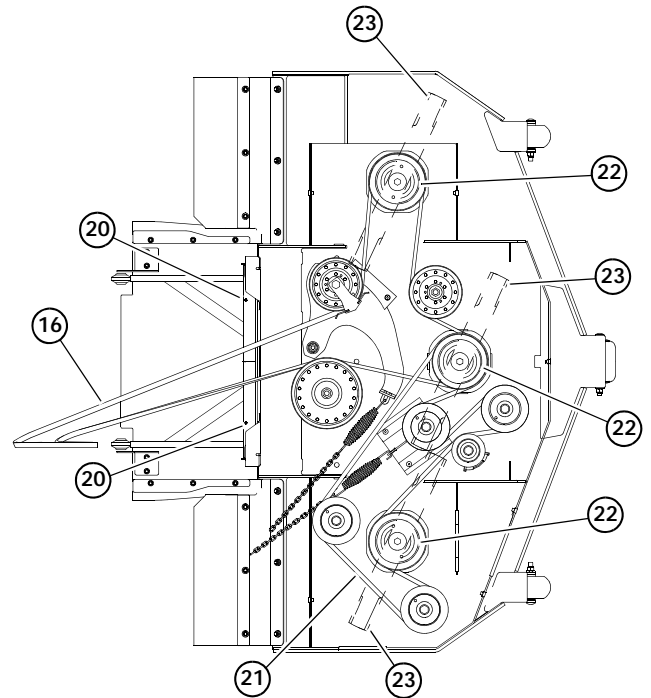

Figure 8-9

TROUBLESHOOTING

SYMPTOMS	PROBABLE CAUSES	SUGGESTED REMEDIES
Starting motor does not crank	Steering control levers not in park brake position or switch not adjusted	Place steering control levers in park brake position or re-adjust switch
	Deck clutch switch engaged	Disengage clutch switch
	Weak or dead battery	Recharge or replace
	Electrical connections are corroded or loose	Check the electrical connections
	For additional causes	See engine manual
The engine will not start, starts hard or fails to keep running	No fuel or line plugged	Fill tank or replace line (See <i>Fuel System</i> section for more details)
	Fuel valve is turned off	Open the fuel valve
	There is incorrect fuel in the fuel system	Drain the tank and replace the fuel with the proper type
	There is dirt in the fuel filter	Replace the fuel filter
	Dirt, water or stale fuel in the fuel system	Contact your dealer
Numerous	See engine manual	
Engine: Runs with continuous misfiring or engine runs unevenly or erratically	Numerous	See engine manual
Loss of power or system will not operate in either direction	Restrictions in air cleaner	Service air cleaner
	Hydraulic line blockage	See your dealer
	Internal interference or leakage in wheel motor	See your dealer
	Insufficient hydraulic oil supply	Check level in reservoir
		Have dealer check hydraulic pump
	Poor compression	See your dealer
	Steering linkage needs adjustment	Adjust linkage
	Tow valve open	Close tow valve
	The traction drive belt is worn, loose or broken	Install a new traction drive belt
Air in system	Check filter and fittings	
For additional causes	See engine manual	
Liquid cooled or Diesel engines overheating: Temperature light glows Frequent refilling of radiator required Coolant appears rusty Audible alarm	Leaks in system	Replace/tighten hoses and connections
	Coolant level low	Add coolant
	Radiator screen clogged	Clean screen
	Thermostat sticking or inoperative	See engine manual
Low engine oil pressure	Heat light malfunction	Contact your dealer
	Low oil level	Add oil
	Oil diluted or too light	Change oil and check for source of contamination
High oil consumption	Failed oil pump	Contact your dealer
	Numerous	Contact your dealer

SYMPTOMS	PROBABLE CAUSES	SUGGESTED REMEDIES
Mower jerky when starting or operates in one direction only	Steering control linkage needs adjustment	Adjust linkage
	Pump or wheel motors faulty	Contact your dealer
	Tow valves not closed completely	Close tow valves
Hydraulic system operates hot (oil in reservoir smells rancid)	Low hydraulic oil level	Fill reservoir
	Hydraulic pump faulty	Contact your dealer
	Hydraulic oil heat exchanger clogged	Clean oil heat exchanger core
Mower creeps when steering control levers are in neutral	Steering linkage needs adjustment	Adjust linkage
Mower circles or veers in one direction	Steering linkage needs adjustment	Adjust linkage
	Wheel motors faulty	Contact your dealer
	Tires improperly inflated	Adjust air pressure to 8 - 12 psi (55 - 83 KPa)
	Hydraulic pump faulty	Contact your dealer
Mower creeps when parking brake engaged	Steering linkage out of adjustment	Adjust steering linkage
	Brakes need adjustment	Adjust parking brakes
There is abnormal vibration	The engine mounting bolts are loose	Tighten the engine mounting bolts
	The engine pulley, idler pulley or blade pulley is loose	Tighten the appropriate pulley
	The engine pulley is damaged	Contact your dealer
	The cutting blade(s) is/are bent or unbalanced	Install new cutting blade(s)
	A blade mounting bolt is loose	Tighten the blade mounting bolt
	Spindle bearing is worn or loose	Replace or tighten spindle bearing
	A blade spindle is bent	Contact your dealer
Blades do not rotate	The deck drive belt is worn, loose or broken	Install a new deck drive belt
	The deck drive belt is off the pulley	Install the deck drive belt and check for a reason
	Electric clutch is not engaging	Check and/or replace 10 amp fuse. Contact your dealer

SYMPTOMS	PROBABLE CAUSES	SUGGESTED REMEDIES
Uneven cutting height	The blade(s) are not sharp	Sharpen the blades
	A cutting blade(s) is/are bent	Install new cutting blade(s)
	The deck is not level	Level the deck per the <i>Deck leveling and height adjustment</i> section of the General Service Manual
	An anti-scalp wheel is not set correctly	Adjust the height of the anti-scalp wheel
	The underside of the deck is dirty	Clean the underside of the deck
	Tires improperly inflated	Adjust air pressure to 8–12 psi (55–83 KPa)
	A blade spindle is bent	Contact your dealer
	Flex Forks [®] are installed	After initial break-in period, level the deck per the Deck Leveling section of the General Service Manual.

INDEX

	PAGE		PAGE
Air Restriction Indicator	5-2	Maintenance Schedule	8-1
Avoid Acid Burns	2-4	Mower Blade Maintenance	6-3
Avoid Fire Hazards	2-2, 2-3	Mower Blade Removal	6-4
Belts	4-6, 6-5	Operate Machine Safely	2-2
Blades	6-3	Operation Precautions	2-2
Control Lever Stops	4-2	Park Brake Adjustment	4-4
Deck Belt adjustment	6-5	Pre-Operation Precautions	2-1
Deck Belt Routing & Tensioning	6-7	Prepare for Emergencies	2-3
Deck Leveling	6-1	Prevent Battery Explosions	2-3
Electrical Schematic	7-1	Safe Servicing Practices	2-1
Engine Air Filter	5-1	Service Program	1-1
Engine Controller	5-3	Special Torques	3-1
Engine Oil and Filter	5-1	Standard Torques	3-1
Engine RPM Settings	5-3	Start Engine Safely	2-2
General Engine Maintenance	5-1	Steering Adjustments	4-1
General Maintenance Precautions	2-2	Steering Control Lever Adjustment	4-3
Hydraulic Oil Heat Exchanger	4-7	Steering Control Lever Neutral Adjustment	4-1
Hydraulic Pump Belt Adjustment	4-6	Steering Damper	4-3
Hydraulic Pump Flow Test	4-7	Tapered Wheel Bearing Replacement	4-12
Hydraulic System	4-7	Tires	4-12
Installation & Testing Procedures	4-8	Understand Correct Service	2-1
Maintenance introduction	1-1	Warner Clutch Re-gap Adjustment Procedures	4-9
Maintenance Locator Chart	8-3	Warranty	1-1
Maintenance Precautions	2-3		