

Hustler® Super 104™ General Service Manual



200 South Ridge Road
Hesston, Kansas
67062

WARNING

The engine exhaust from this product contains chemicals known to the state of California to cause cancer, birth defects or other reproductive harm.

NOTICE OF REQUIREMENT OF SPARK ARRESTER MUFFLER

This equipment may create sparks that can start fires around dry vegetation. California Public Resources Code Section 4442.6 provides that it is unlawful to use or operate an internal combustion engine on any forest-covered, brush-covered, or grass-covered land unless the engine is equipped with a spark arrester maintained in effective working order. A spark arrester is a device constructed of nonflammable materials specifically for the purpose of removing and retaining carbon and other flammable particles over 0.0232 of an inch in size from the exhaust flow of an internal combustion engine that uses hydrocarbon fuels or which is qualified and rated by the United States Forest Service. Other states or federal areas may have similar laws. The Operator Should Contact Local Fire Agencies For Laws or Regulations Relating to Fire Prevention Requirements. **THIS EQUIPMENT DOES NOT HAVE A SPARK ARRESTER AND YOU SHOULD CONTACT YOUR AUTHORIZED DEALER FOR THE PURCHASE OF A SPARK ARRESTER.**

Inspect spark arrester daily; replace every 500 hours or as needed.

The Engine Owner's Manual provides information regarding the U.S. Environmental Protection Agency (EPA) and the California Emission Control Regulation of emission systems, maintenance and warranty.

Keep Engine Owner's Manual with your unit. Should the Engine Owner's Manual become damaged or illegible, replace immediately. Replacements may be ordered per the information found in the Product Information section of the owner's manual.

Federal law and California State law prohibit the following acts or the causing thereof:

1. The removal or rendering inoperative by any person other than for purposes of maintenance, repair, replacement, of any device or element of design incorporated into any equipment for the purposes of emissions control prior to or after its sales or delivery to the ultimate purchaser or while it is in use, or
2. The use of the equipment after such device or element of design has been removed or rendered inoperative by any person.

Table of Contents

General Information	1-1
Hustler Service Program	1-1
Maintenance Introduction	1-1
Warranty	1-1
Safety	2-1
Safe Servicing Practices	2-1
Pre-Operation Precautions	2-1
Operation Precautions	2-2
Operate Machine Safely	2-2
General Maintenance Precautions	2-2
Maintenance Precautions	2-3
Torque	3-1
Standard Torques	3-1
Special Torques	3-1
Power Unit Maintenance	4-1
Steering Adjustments	4-1
Park Brake Adjustment	4-5
Belts	4-6
Hydraulic Pump Belt Adjustment	4-6
Hydraulic System	4-6
Checking the Deck Lift Circuit Pressure	4-7
Test Procedure for DDC20 Pump	4-9
New or Rebuilt DDC20 Pump Startup Procedure	4-10
Warner Clutch Re-gap Adjustment Procedures	4-12
Caster Fork Tapered Bearings Replacement	4-15
Tapered Wheel Bearing Replacement	4-16
Tires	4-18
Engine Maintenance	5-1
General Engine Maintenance	5-1
Engine Oil and Filter	5-1
Engine Air Filter	5-2
Fuel Evaporation System Filter	5-4
Fuel & Evaporative System Line Routings	5-4
Engine RPM Settings	5-6

Deck Adjustments	6-1
Deck Leveling	6-1
Blades	6-4
Belts	6-6
Center Deck Belts Adjustment	6-6
Side Deck Belt Adjustment	6-6
Deck Troubleshooting	6-6
Electrical	7-1
Maintenance	8-1
Maintenance Locator Chart	8-3
Troubleshooting	9-1
Deck Zone Chart	9-5

GENERAL INFORMATION

Hustler Service Program

This manual is part of a service package for the Hustler® Super 104™ mower. Use of this manual in conjunction with other Hustler® mower and component manuals will provide the information necessary to service and maintain Hustler® Super 104™ mowers.

This General Service Manual is a service guide for use by Service Technicians. It provides the necessary information needed to perform normal maintenance requirements on these units.

The Parts Manual provides a complete parts listing for the unit. Use this manual when ordering parts.

The Operator's Manual provides fundamental operational information and operational safety that is needed when operating the mower.

The component manuals are furnished by the various manufacturers to be used for the troubleshooting and servicing of their components.

Maintenance Introduction

Regular maintenance is the best prevention for downtime or premature failure. The following pages contain suggested maintenance information and schedules which the operator/mechanic should follow on a routine basis.

Remain alert for unusual noises, they could be signaling a problem. Visually inspect the machine for any abnormal wear or damage. A good time to detect potential problems is while performing scheduled maintenance service. Correcting the problem as quickly as possible is the best insurance.

Clear away heavy build-up of grease, oil and dirt, especially in the engine compartment and under the seat platform areas; minute dust particles are abrasive to close-tolerance engine and hydraulic assemblies.

Daily inspect mower for grass clippings and wire and string tangles. The underside of the mower deck will collect a build-up of grass clippings and dirt, especially when grass is wet or has high moisture content. This build-up will harden, restricting blade and air movement and will probably show a lesser quality of cut. Therefore it should be removed routinely.

To do this it will be necessary to raise and block the deck, using jack stands or blocks, in the full up position and scrape the build-up from underneath.

Some repairs require the assistance of a trained service mechanic and should not be attempted by unskilled personnel. Consult your Hustler® Turf Equipment service center when assistance is needed.

Information included in this manual was current at the time of printing, but subsequent production changes may cause your machine to vary slightly in detail. Hustler® Turf Equipment reserves the right to redesign and change the machine as deemed necessary, without notification. If a change has been made to your machine which is not reflected in this service manual contact the Customer Service Department at Hustler® Turf Equipment for additional information.

Warranty

Warranty repair must be performed by a Hustler® Turf Equipment Authorized Dealer before warranty credit can be allowed.

SAFETY



This safety alert symbol is used to call attention to a message intended to provide a reasonable degree of PERSONAL SAFETY for operators and other persons during the normal operation and servicing of this equipment.

⚠ DANGER ⚠	– denotes immediate hazards which WILL result in severe personal injury or death.
---------------------------------------	--

⚠ WARNING ⚠	– denotes a hazard or unsafe practice which COULD result in severe personal injury or death.
--	---

Safe Servicing Practices

Refer to the *Safety Precautions* section of this manual for more service safety information.

Understand correct service

- ▲ Be sure you understand a service procedure before you work on the machine.
- ▲ Unauthorized modifications to the machine may impair the function and/or safety and affect machine life.
- ▲ If it is necessary to make checks with the engine running, always use two people - with the operator at the controls, able to see the person doing the checking.

Pre-Operation Precautions

Fuel Handling

- ▲ To avoid personal injury or property damage, use extreme care when handling gasoline. Gasoline is extremely flammable and the vapors are explosive.
 - A fire or explosion from gasoline can burn you and others and can damage property.
- ▲ Observe the usual gasoline handling precautions:

- Do not smoke while refueling. Extinguish all cigarettes, cigars, pipes and other sources of ignition.
 - Do not remove fuel cap or fill tank with engine running or while engine is hot. Clean up any gasoline spills.
 - If gasoline is spilled, do not attempt to start the engine but move the machine away from the area of spillage and avoid creating any source of ignition until gasoline vapors have dissipated.
 - Keep gasoline away from open flame or spark and store machine away from open flame or spark or pilot light such as on a water heater or appliances.
 - Refuel outdoors. Never refuel or drain the gasoline from the machine indoors, or while in an enclosed trailer or other enclosed area.
 - Never attempt to start the engine when there is a strong odor of gasoline fumes present. Locate and correct the cause.
 - Store gasoline in an approved container and keep it out of the reach of children. Never buy more than a 30-day supply of gasoline.
 - Do not fill fuel containers inside a vehicle or on a truck or trailer bed with interior carpets or plastic truck bed liners. Always place gasoline containers on the ground away from your vehicle before filling.
 - When practical, remove the machine from the truck or trailer and refuel the machine with its wheels on the ground. If this is not possible, then refuel such machine on the truck or trailer using a portable container and not a fuel dispenser nozzle. If a fuel dispenser nozzle must be used, keep the nozzle in contact with the rim of the fuel tank or container opening at all times until fueling is complete. Do not use a nozzle lock-open device.
 - Never use gasoline for cleaning parts.
 - Read and observe safety precautions elsewhere in this manual.
- ▲ Gasoline is harmful or fatal if swallowed.
 - ▲ Avoid prolonged breathing of vapors.
 - Long-term exposure to vapors can cause serious injury and illness.
 - ▲ Keep gasoline away from eyes and skin.
 - Keep face away from nozzle and fuel tank or fuel container opening.
 - If gasoline is spilled on clothing, change clothing immediately.

Understand Machine Operation

- ▲ Only qualified and trained personnel should operate the equipment.
- ▲ Carefully read the operator's manual and all manuals furnished with the attachments. Learn the location and purpose of all controls, instruments, indicators and labels.

Wear Protective Clothing

- ▲ Do not operate or service the equipment while wearing sandals, tennis shoes, sneakers, shorts or any type of loose fitting clothing. Long hair, loose clothing or jewelry may get tangled in moving parts. Always wear long pants, safety glasses, ear protection and safety shoes when operating or servicing this machine.
- ▲ Always wear adequate eye protection when servicing the hydraulic system and battery, or when grinding mower blades and removing accumulated debris.
- ▲ Prolonged exposure to loud noise can cause impairment or loss of hearing.
 - Always wear adequate ear protection, such as earplugs, when operating this equipment as prolonged exposure to uncomfortable or loud noises can cause impairment or loss of hearing.
 - Do not wear radios or music headphones while operating the machinery. Safe operation requires your full attention.

Operation Precautions

Avoid Fire Hazards

- ▲ **Clean flammable material from machine. Prevent fires by keeping engine compartment, top of deck, exhaust area, battery, hydraulic lines, fuel line, fuel tank and operator's station clean of accumulated trash, grass clippings, and other debris. Always clean up spilled fuel and oil.**

Start Engine Safely

- ▲ Avoid possible injury or death from machine runaway.
- ▲ Do not start engine by shorting across starter terminals.
- ▲ Before you start the engine:
 - Sit on the operator's seat.
 - Move control levers to the neutral/brake position.

Operate Machine Safely

- ▲ Refer to the unit's operator's manual for complete safety information on safe machine operation.
- ▲ Always maintain a safe distance from people and pets when mowing
- ▲ Always be aware of what is behind the machine before backing up.

- ▲ Never leave machine unattended with ignition key in switch, especially with children present.
- ▲ Follow daily and weekly checklists, making sure hoses are tightly secured and bolts are tightened.
- ▲ Always keep engine and machine clean, removing accumulated dirt, trash and other material from machine.
- ▲ Never put hands or feet under any part of the machine while it is running.
- ▲ Never attempt to start engine when there is a strong odor of gasoline fumes present. Locate and correct cause.
- ▲ Keep all safety shields and covers in place, except for servicing.
- ▲ Do not touch hot parts of machine.

General Maintenance Precautions

- ▲ **Repairs or maintenance requiring engine power should be performed by trained maintenance personnel only.**
- ▲ Never run the engine in an enclosed area unless exhaust is vented to the outside. Exhaust gases contain carbon monoxide which is an odorless and deadly poison.
- ▲ Unless specifically required, **DO NOT** have the engine running when servicing or making adjustments to the mower.
 - Park the mower on level ground
 - Disengage the deck clutch.
 - Place the steering control levers in the park brake position.
 - Lower the deck.
 - Stop the engine.
 - Remove the ignition key.
 - Disconnect the negative battery cable.
 - Wait for all movement to stop before adjusting, cleaning or repairing.
 - Repairs or maintenance requiring engine power should be performed by trained maintenance personnel only.
 - To prevent carbon monoxide poisoning, operate the engine in a well ventilated area only.
 - Read and observe all safety warnings in this manual.
- ▲ Before working on or under the deck, make certain engine cannot be accidentally started. Shut engine off, remove ignition switch key and disconnect negative battery cable for maximum safety.
- ▲ Except when changing or checking belt, **always** keep belt covers on mower deck for safety as well as cleanliness.

- ▲ Use a stick or similar instrument to clean under the mower making sure that no part of the body, especially arms and hands are under mower.
- ▲ Keep your machine clean and remove any deposits of trash and clippings, which can cause engine fires and hydraulic overheating as well as excessive belt wear. Clean up oil or fuel spillage.
- ▲ Allow the mower, especially the engine, to cool in a well ventilated area before storing inside a building or other enclosure.
- ▲ Always wear adequate eye protection when servicing the hydraulic system and battery, or when grinding mower blades and removing accumulated debris.
- ▲ Never attempt to make any adjustments or repairs to the mower drive system, mower deck or any attachment while the engine is running or deck clutch is engaged.
- ▲ Exercise caution when releasing spring tension from any of the belt idlers or when working with any of the deck lift components.
- ▲ Never work under the machine or attachment unless it is safely supported with jack stands. Make certain machine is secure when it is raised and placed on the jack stands. The jack stands should not allow the machine to move when the engine is running and the drive wheels are rotating. **Use only certified jack stands.** Use only appropriate jack stands, with a minimum weight rating of 2000 pounds to block the unit up. Use in pairs only. Follow the instructions supplied with the vehicle stands.
- ▲ Keep nuts and bolts tight, especially the blade attachment bolts. Keep equipment in good working condition.
- ▲ Never tamper with safety devices. Check their proper operation regularly.
- ▲ Exercise caution when working under the deck as the mower blades are extremely sharp. Wrap the blade(s) or wear gloves and use extra caution when servicing them.
- ▲ Use original Hustler® replacement parts or parts that are equivalent in overall performance.
 - The mower may not comply with the appropriate safety standards if aftermarket parts, accessories, or attachments are used.

Maintenance Precautions

Avoid Fire Hazards

- ▲ Be prepared if an accident or fire should occur. Know where the first aid kit and the fire extinguishers are located and how to use them.
- ▲ Provide adequate ventilation when charging batteries.
- ▲ Do not smoke near battery.
- ▲ Never check fuel level with an open flame.

- ▲ Never use an open flame to look for leaks anywhere on the equipment.
- ▲ Never use an open flame as light anywhere on or around the equipment.
- ▲ When preparing engine for storage, remember that fuel stabilizer is volatile and therefore dangerous. Seal and tape openings after adding the inhibitor. Keep container tightly closed when not in use.
- ▲ Inspect electrical wiring for worn or frayed insulation. Install new wiring if wires are damaged.

Prepare for Emergencies

- ▲ Be prepared if a fire starts.
- ▲ Keep a first aid kit and fire extinguishers available.
- ▲ Keep emergency numbers for doctor, ambulance service, hospital, and fire department near the telephone.

Prevent Battery Explosions

- ▲ Battery posts, terminals, and related accessories contain lead and lead compounds, chemicals known to the State of California to cause cancer and reproductive harm. Wash hands after handling.
- ▲ Charge batteries in a well-ventilated open area, away from sparks and flames. Unplug charger before connecting or disconnecting from battery. Wear protective clothing and use insulated tools.
- ▲ Avoid skin and clothing contact with battery acid.
 - Always wear eye protection when checking the battery. Acid can cause serious injury to skin and eyes. If contact occurs, flush area with clean water and call a physician immediately. Acid will also damage clothing.
 - Do not drink the battery electrolyte.
 - Do not allow open flame near the battery when charging.
 - Hydrogen gas forms inside the battery. This gas is both toxic and flammable and may cause an explosion if exposed to flame. Always **disconnect** the negative (black) battery cable(s) before disconnecting the positive (red) cable(s). Always **connect** the positive (red) battery cable(s) before connecting the negative (black) cable(s).
 - Do not overfill the battery.
 - Electrolyte may overflow and damage paint, wiring or structure. When cleaning the battery, use soap and water. Be careful not to get soap and water into the battery. Clean the battery terminals with a solution of four parts water and one part baking soda when they become corroded.
- ▲ Shorts caused by battery terminals or metal tools touching metal mower components can cause sparks.

Sparks can cause a battery gas explosion which will result in personal injury.

- Prevent the battery terminals from touching any metal mower parts when removing or installing the battery.
 - Do not allow metal tools to short between the battery terminals and metal mower parts.
- ▲ Incorrect battery cable routing could cause damage to the mower and battery cables. This can cause sparks which can cause a battery gas explosion which will result in personal injury.
- Always **disconnect** the negative (black) battery cable(s) before disconnecting the positive (red) cable(s).
 - Always **connect** the positive (red) battery cable(s) before connecting the negative (black) cable(s).

If you spill acid on yourself:

- Flush your skin with water.
- Apply baking soda or lime to help neutralize the acid.
- Flush your eyes with water for 10–15 minutes. Get medical attention immediately.

If acid is swallowed:

- Drink large amounts of water or milk.
- Then drink milk of magnesia, beaten eggs or vegetable oil.
- Get medical attention immediately.

Avoid Acid Burns

- ▲ Sulfuric acid in battery electrolyte is poisonous. It is strong enough to burn skin, eat holes in clothing and cause blindness if splashed in eyes.

Avoid the hazard by:

- Filling batteries in a well-ventilated area.
- Wearing eye protection and rubber gloves.
- Avoiding breathing fumes when electrolyte is added.
- Avoiding spilling or contacting dripped electrolyte.

TORQUE

Standard Torques

The following chart lists the standard torque values for the threaded fasteners found in this manual. Torque all cap screws, nuts and set screws to these values unless a different torque is shown in the *Special Torques* section.

Size	ft-lbs	N•m	Size	ft-lbs	N•m
#10	32.4 IN.-LBS.	3.6	M3	12 IN.-LBS.	1.3
.250	98.4 IN.-LBS.	11.1	M4	26.4 IN.-LBS.	3
.312	204 IN.-LBS.	23	M5	54 IN.-LBS.	6.1
.375	30	40	M6	92.4 IN.-LBS.	10.4
.438	48	65	M8	222 IN.-LBS.	25
.500	73	99	M10	37	50
.562	105	143	M12	64	87
.625	145	200	M14	103	140
.750	260	350	M16	160	215
.875	420	565	M20	320	435

Special Torques

Size	ft-lbs	N•m
Wheel (lug) nuts ¹	70	95
Blade spindle bolt top	70	95
Blade spindle bolt bottom	118	160.01
Electric clutch mounting bolt ³	45–48	61–65
Front wheel axle bolt	100	136
Wheel motor hub nut	230	312
Hydraulic pump pulley screw	14	19
Engine torques ²	N/A	N/A

NOTE:

- Lug nuts only** — It is recommended that these be checked after the first 2 hours of operation and every 50 hours and following removal for repair or replacement.
- Engine torque values** — Refer to the respective engine owner's manual.
- If clutch mounting bolt is loosened or removed, **do not re-use**. Replace with a new bolt. Use only hand tools to install this fastener.



WARNING

Particular attention must be given to tightening the drive wheel lug nuts and blade spindle bolts. Failure to correctly torque these items may result in the loss of a wheel or blade, which can cause serious damage or personal injury.

POWER UNIT MAINTENANCE

Steering Adjustments

Steering Control Lever Neutral Adjustment

The mower's steering has been factory adjusted to eliminate creeping when the steering control levers are in the neutral position. However, should the mower begin to creep, the steering control lever linkage can be adjusted.

Before considering any adjustment, check the tire air pressure. Unequal tire pressure will cause the mower to drift to one side. Refer to tire pressure information in the *Tires* section for detailed information.

Make certain the hydraulic system oil is at operating temperature before making adjustments.

NOTE: Proper park brake adjustment must be completed before the steering control lever neutral adjustment can be done. Refer to the *Park Brake Spring Adjustment* section for detailed information.

Fine adjustment to the unit's steering is made with the transmission's control rod.

Neutral is properly adjusted when the steering control levers are in the park brake position and the transmissions do not "whine".

If this occurs, the steering control linkage may be adjusted as follows:

WARNING

Never work under the machine or attachment unless it is safely supported with jack stands.

- Make certain machine is secure when it is raised and placed on the jack stands.
- **Use only certified jack stands.** Use only appropriate jack stands, with a minimum weight rating of 2000 pounds (907 kg) to block the unit up.
- Use in pairs only.
- Follow the instructions supplied with the jack stands.
- The jack stands should not allow the machine to move when the engine is running and the drive wheels are rotating.
- Do not allow the wheels to come in contact with the floor or any object that would permit the unit to popel itself.
- To prevent injury stay clear and exercise caution when rotating the wheels.

WARNING

Untrained maintenance personnel should never attempt to make any adjustments or repairs to the mower's drive system while the engine is running. **The following procedures should be performed by trained maintenance personnel only.**

1. Raise the rear of the mower and block with certified jack stands. The rear wheels need to be able to rotate freely and clear of all obstructions.
2. Check the front tires.
3. Raise the seat platform and disconnect the mower harness from the seat switch. Bypass the seat switch by connecting the two mower harness female spade connectors together. Figure 4-1

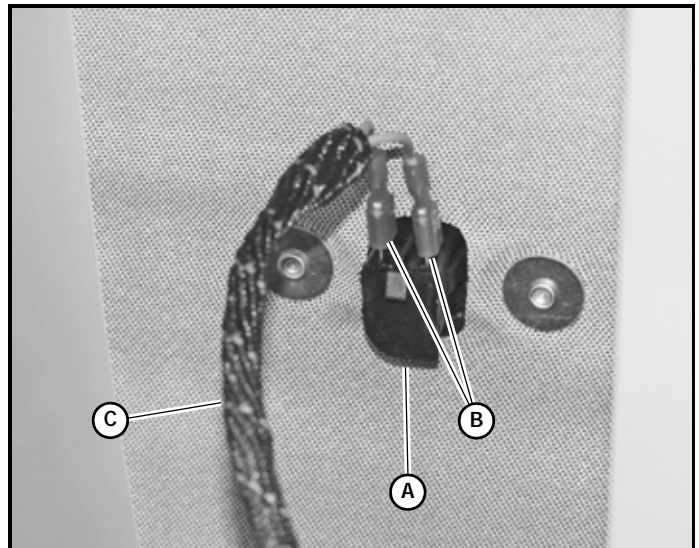

- A. Seat switch
- B. Female spade connectors
- C. Mower harness

Figure 4-1

4. Start the engine.
5. Position the steering control lever in the neutral position and observe which way the wheels are rotating. Figure 4-2
6. If wheel(s) are rotating forward, loosen the jam nuts on the pump linkage rods and rotate the rod to lengthen the steering control linkage until the wheel(s) come to a stop. Figure 4-3
7. Repeat for the opposite side if necessary.
8. If wheel(s) are rotating in reverse then loosen the jam nuts on the pump linkage rods and rotate the rod to shorten the steering control linkage until the wheel(s) come to a stop. Figure 4-3

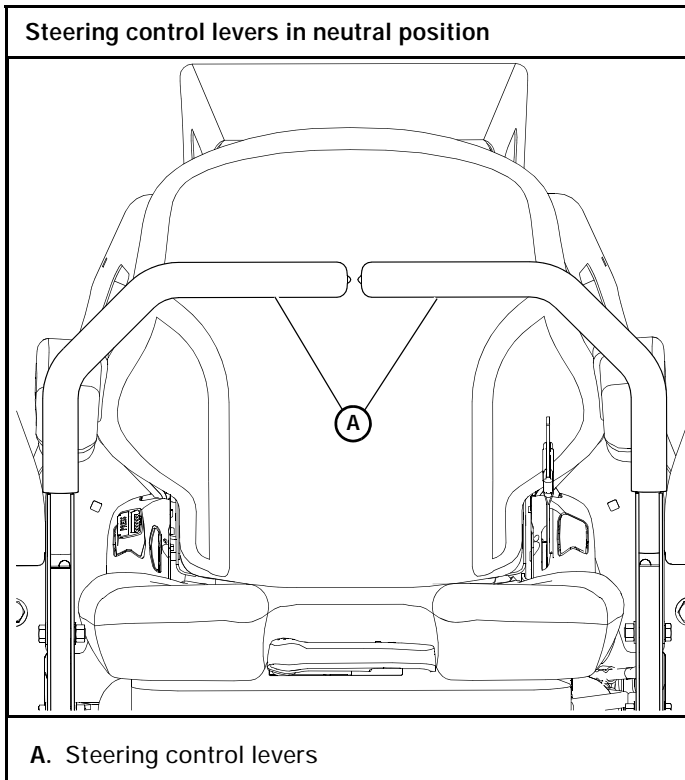

Figure 4-2

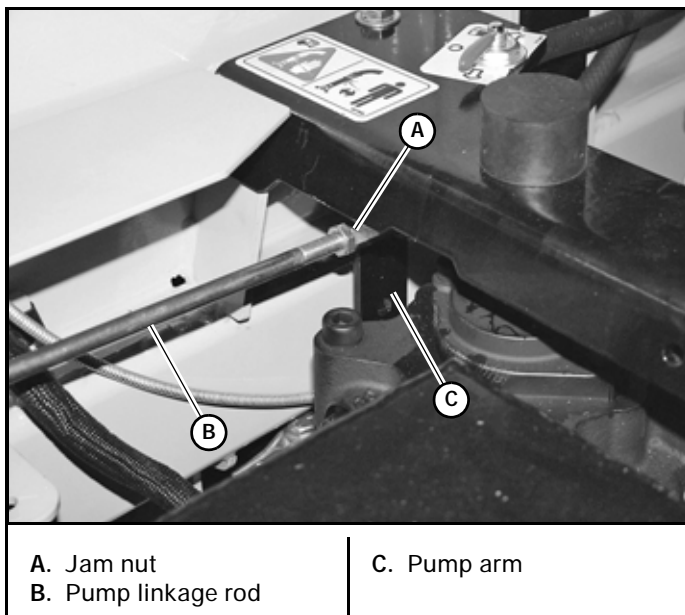

Figure 4-3

Repeat for the opposite side if necessary

9. When both wheels remain in neutral, tighten the jam nuts to lock the turnbuckle in place.
10. Test again by moving the steering control levers forward and backward before returning them to the neutral position. If the tires are in neutral, the unit is now ready for operation.
11. After adjusting for neutral it may be necessary to re-adjust the control lever stop and/or damper.

12. **IMPORTANT:** With the engine off, disconnect the two female spade connectors from each other (from step #3) and reconnect them to the seat switch. This must be completed so that the safety circuit is functioning properly. Figure 4-1

WARNING Do not operate the mower without plugging the mower's wiring harness into the seat switch. This switch is an important part of the safety start interlock system. Serious injury can result if the seat switch is not plugged into the mower's wiring harness.

WARNING Never operate the mower with a non-functioning seat switch. Check the mower's safety start interlock system daily, prior to operation, to make sure the seat switch is functioning properly.

13. Check to make sure all tools or obstructions are removed from under the mower.
14. Raise the rear of the mower and remove the jack stands. Lower the mower.
15. Lower and secure the seat platform.

Control Lever Stops

The internal steering control lever stops (see Figure 4-4) are designed to keep the pumps from bottoming out internally. The external steering control lever stops (see Figure 4-5) may be adjusted to help the mower drive straight when the steering control levers are pushed forward against the stops.

To keep the pumps from bottoming out internally use the following procedure:

This adjustment is only required if the hydraulic pump(s) have been replaced.

WARNING Pump damage will occur if these stops are set incorrectly.

1. To make the first adjustment the mower engine must **not** be running.
2. Check to make sure the steering control levers are against the stops before the pumps are bottomed out internally.
3. To do this, gently and slowly move the steering control levers forward and feel if there is some resistance on the pump lever before the control levers hit the stops. Check one side at a time. If you sense that the pump

arms are stopping the forward motion of the control arms, loosen the jam nut on the adjustable stop of the corresponding side, turn the stop (set screw) inward to stop the steering control levers slightly before the pump bottoms out. Lock in place when the adjustment is correct by re-tightening the jam nut. Do this for each side. Figure 4-4

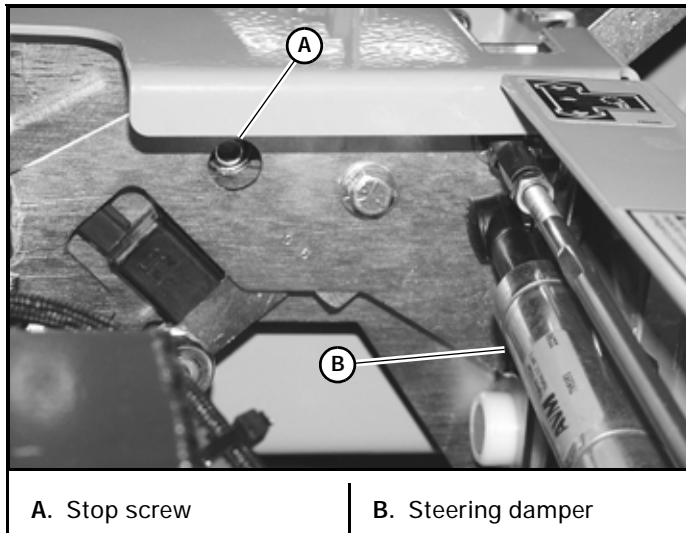

Figure 4-4

To adjust the stops for driving straight when steering control levers are against the stops during operation:

1. Determine which drive tire is rotating too fast when both steering control levers are against the stops in the control panel (see Figure 4-5).
2. Then, stop the mower and loosen the lock nut on the side which is rotating too fast and turn the stop (set screw) inward to stop the steering control lever sooner. Tighten the lock nut on the stop and test again.
3. Repeat this procedure until unit drives straight.

NOTE: Since this is a hydrostatic drive, variables such as temperature of oil, efficiency of pumps and motors, tire pressure etc. may affect the consistency of the ability to rely on the stops to drive straight without the operator making minor steering adjustments with the control arms.

Steering Damper

The steering dampers are spring loaded to return the control levers to the neutral position from the reverse position. This gives the operator a sense of neutral during operation.

To set the steering dampers in the correct operating position follow these steps:

1. Shut engine off, place steering control levers in the park brake position, disengage deck clutch, remove ignition switch key and disconnect negative battery cable before doing any adjustments.

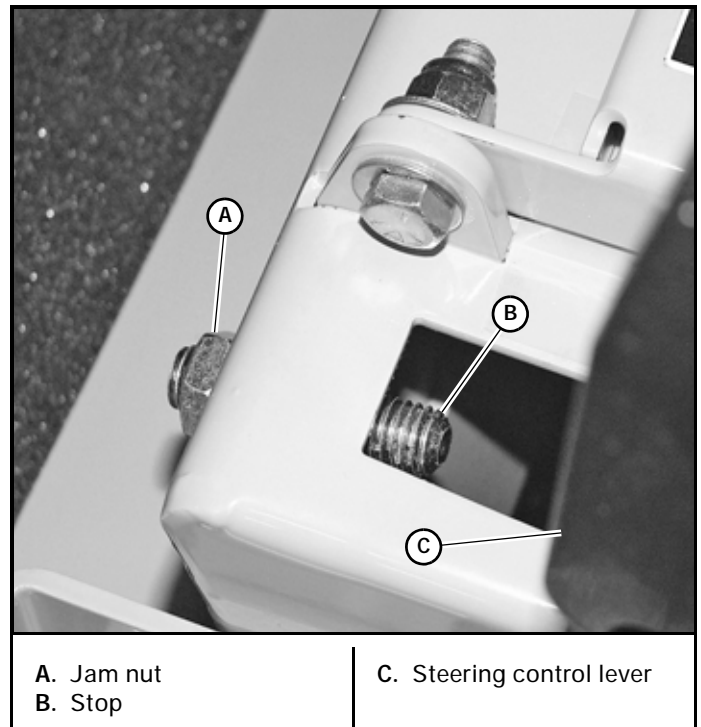

Figure 4-5

2. Place the steering control lever in the neutral position. Figure 4-6
 3. Loosen the steering damper's rear ball stud. Figure 4-7
 4. Pull the damper spring housing past the point that the internal spring is engaged. Figure 4-7
 5. Release the damper spring housing and allow the internal spring to bring the housing back to the neutral position.
 6. Tighten the nut on the steering damper's front ball stud.
- NOTE:** The damper must not bottom out when the pump lever is fully stroked in either direction.
7. Reconnect the negative battery cable.
 8. Lower and secure the seat platform.
 9. To check, move the steering control lever to the reverse position and release. The steering control lever should return to the neutral position. If not, repeat steps 1 through 6.

Steering Control Lever Adjustment

The steering control levers can be adjusted for operator comfort.

1. By loosening the cap screws that attach the upper control lever to the lower lever the upper control lever can be pivoted to fit the operator's personal preference (see Figure 4-8).
2. The steering control levers should be adjusted so that they align vertically with each other when in the neutral position. Figure 4-9



Figure 4-6

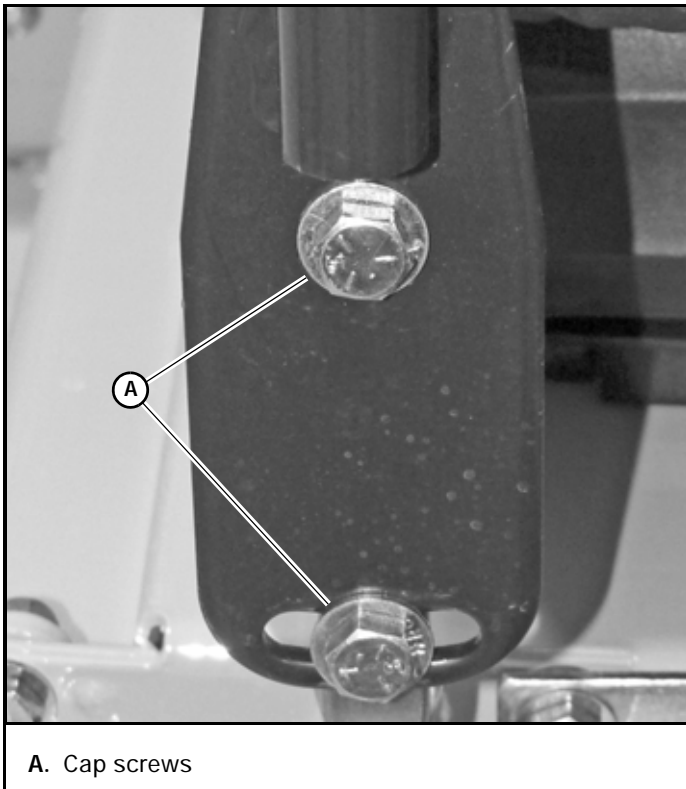

Figure 4-8

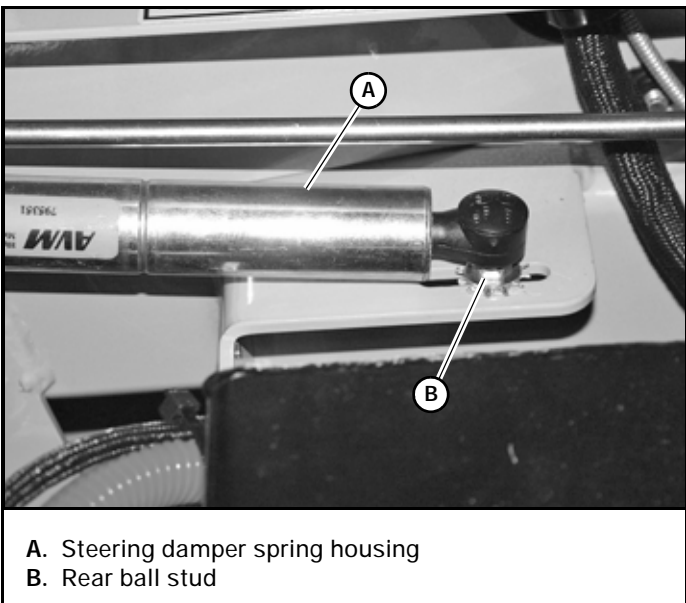

Figure 4-7

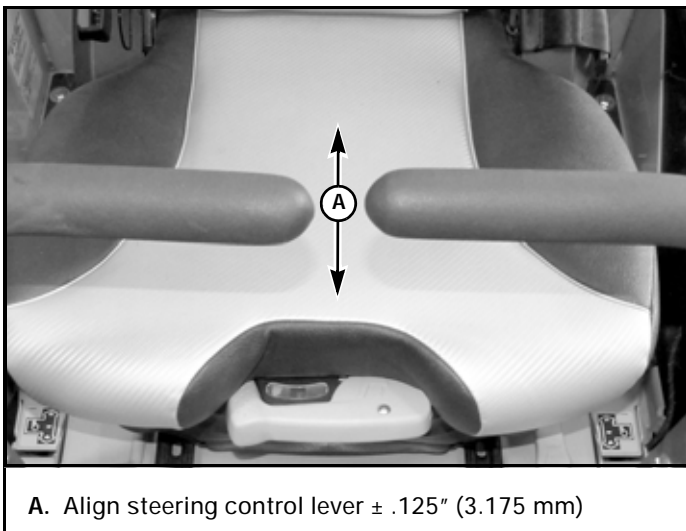

Figure 4-9

Park Brake Adjustment

WARNING

Never work under the machine or attachment unless it is safely supported with jack stands.

- Make certain machine is secure when it is raised and placed on the jack stands.
- Use **only certified jack stands**. Use only appropriate jack stands, with a minimum weight rating of 2000 pounds (907 kg) to block the unit up.
- Use in pairs only.
- Follow the instructions supplied with the jack stands.
- The jack stands should not allow the machine to move when the engine is running and the drive wheels are rotating.
- Do not allow the wheels to come in contact with the floor or any object that would permit the unit to propel itself.
- To prevent injury stay clear and exercise caution when rotating the wheels.

1. Shut engine off, place steering control levers in the park brake position, disengage deck clutch, remove ignition switch key and disconnect negative battery cable before doing any adjustments.
2. Raise the rear of the mower and block with certified jack stands. The rear wheels need to be able to rotate freely and clear of all obstructions.
3. Chock the front tires.
4. Position the steering control levers in the neutral position.

NOTE: The front brake link is not to be adjusted. Figure 4-10

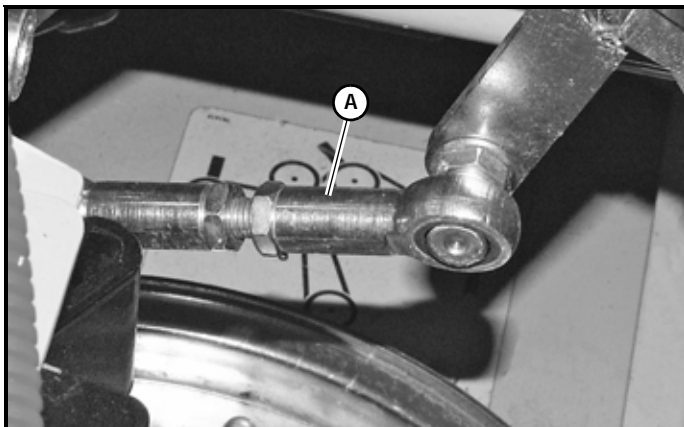

A. Brake link

Figure 4-10

5. Open the hydraulic pump's bypass valve, on the side that is being adjusted, by turning the bypass valve counter clockwise one-half to one revolution. Figure 4-11

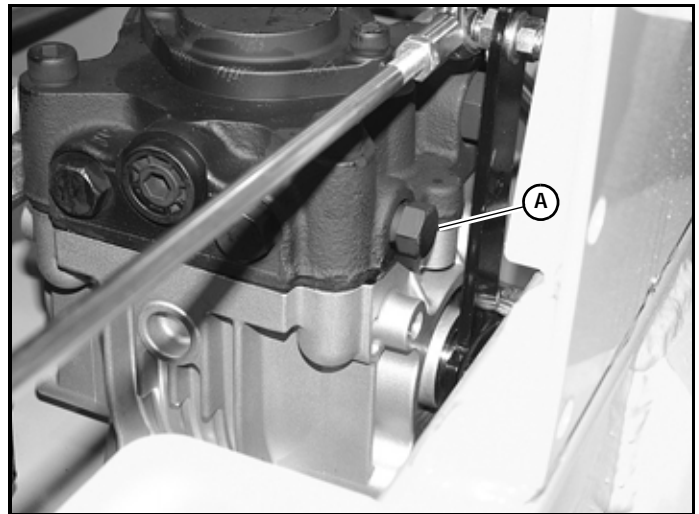

A. Bypass valve

Figure 4-11

6. Try and rotate the tire by hand. The tire should rotate. Remember hydraulic oil resistance will prevent the tire from rotating freely even with the bypass valves open. There should be no resistance from the brakes at this point.
7. Move the steering control lever to where it is just inside (1/4" [6.35 mm]) the park brake slot. Figure 4-12

NOTE: When the steering control lever is against the outside edge of the slot, the brakes should **not** be engaged.

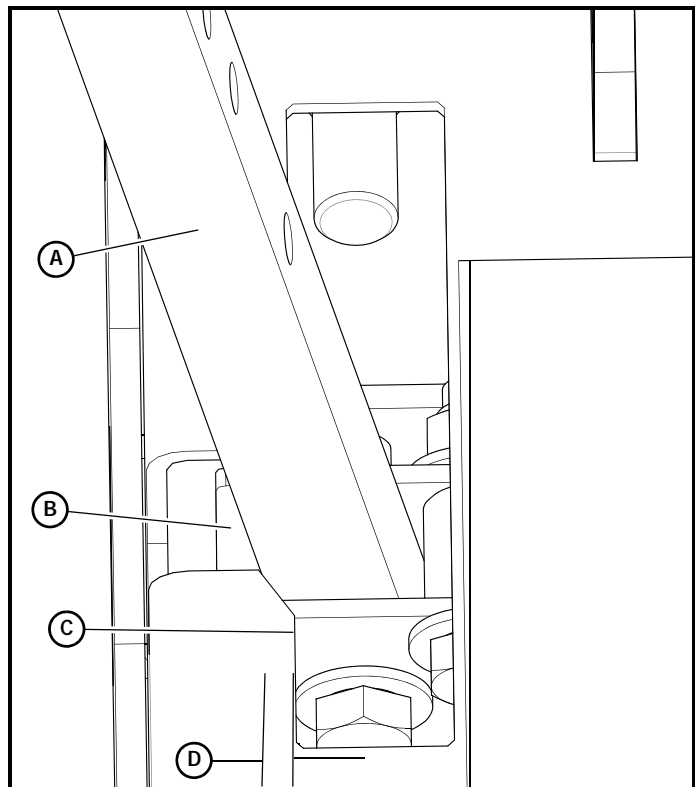

A. Steering control lever
B. Park brake slot

C. Outside edge
D. 1/4" (6.35 mm)

Figure 4-12

8. Rotate the tire. If the brake is adjusted properly the tire will still rotate but friction will start to become noticeable here. However, if no brake resistance is noticed, the brake needs adjusted as follows:
 - a. Loosen the brake linkage jam nuts. (Figure 4-13) Rotate the tire and at the same time rotate the turnbuckle to shorten the length of the brake linkage to increase the brake pressure. When you feel the brake begin to engage, stop adjusting the turnbuckle. Re-tighten the jam nuts on the turnbuckle.
 - b. Place the control lever in the park brake slot. The tire should not rotate when the control lever is in the park brake position. Figure 4-12
 - c. Place the control lever in the neutral position. The tire should rotate freely.
9. Close the hydraulic pump's bypass valve. Figure 4-11
10. Repeat steps 4 through 9 for the other side.
11. Check to make sure all tools or obstructions are removed from under the mower.
12. Raise the rear of the mower and remove the jack stands. Lower the mower.
13. Reconnect the negative battery cable.
14. Lower and secure the seat platform.

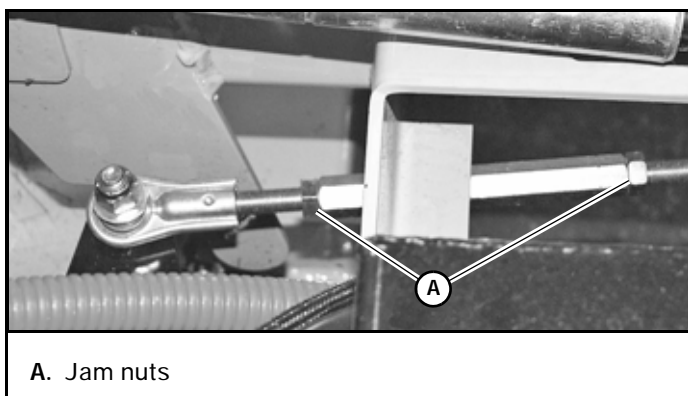

Figure 4-13

Belts

Inspect belts frequently for wear and serviceability. Replace a belt that shows signs of:

- severe cuts
- tears
- separation
- weather checking
- cracking
- burns caused by slipping.

Slight raveling of belt covering does not indicate failure, trim ravelings with a sharp knife.

Inspect the belt pulley grooves and flanges for wear. A new belt, or one in good condition, should never run against the bottom of the groove. Replace the pulley when this is the case, otherwise, the belt will lose power and slip excessively.

Never pry a belt to get it on a pulley as this will cut or damage the fibers of the belt covering.

Keep oil and grease away from belts, and never use belt dressings. Any of these will destroy the belt composition in a very short time.

Hydraulic Pump Belt Adjustment

The transmission drive belt tension remains constant by means of a tension idler and spring. The spring tension should be such that the belt does not slip under normal operating load conditions, assuming the belt is not excessively worn or damaged. As the belt stretches and wears in, adjustment may become necessary.

The proper belt tension is achieved when the tension spring is stretched to a dimension of 8.75"–9.25" (222–223 mm) when measured from the outside of the hook to the outside of the other hook. Figure 4-14

To increase belt tension, loosen the jam nut on the eye bolt. Then, tighten the nut on the eyebolt until the 8.75"–9.25" (222–223 mm) dimension is attained. Lock the eyebolt in place by tightening the jam nut. Figure 4-14

IMPORTANT: Do not over-tension the spring to compensate for a badly worn belt or pulley. Figure 4-14

Inspect the spring tension adjustment after the first 50 hours. Adjust as needed.

Inspect the belt every 100 hours and replace as needed. Replace the belt every 400 hours or every two (2) years whichever comes first.



If the transmission belt fails, loss of control will occur especially when operating on a slope. If you lose steering control while operating the machine, place the steering control levers in the park brake position immediately. Inspect the machine and involve your dealer to resolve the problem.

Hydraulic System

IMPORTANT: Never use hydraulic or automatic transmission fluid in this system; use only motor oil as specified. Remember, dirt is the primary enemy of any hydraulic system.

Check oil level in hydraulic system after every 50 hours of operation or weekly, whichever occurs first. Check more often if system appears to be leaking or otherwise malfunctioning.

Fluid level should be 1" (25.4 mm) from top of reservoir. Use only **15W50 synthetic oil** or **20W50 synthetic oil**. Hustler Full Synthetic 20W50 Hydrostatic Transmission Oil is recommended. Figure 4-15

NOTE: The reservoir will require approximately 3 U.S. gallons (11.35 liter) of 15W50 synthetic oil or 20W50 synthetic oil when replacing the oil after an oil and filter change. Do not overfill the reservoir.

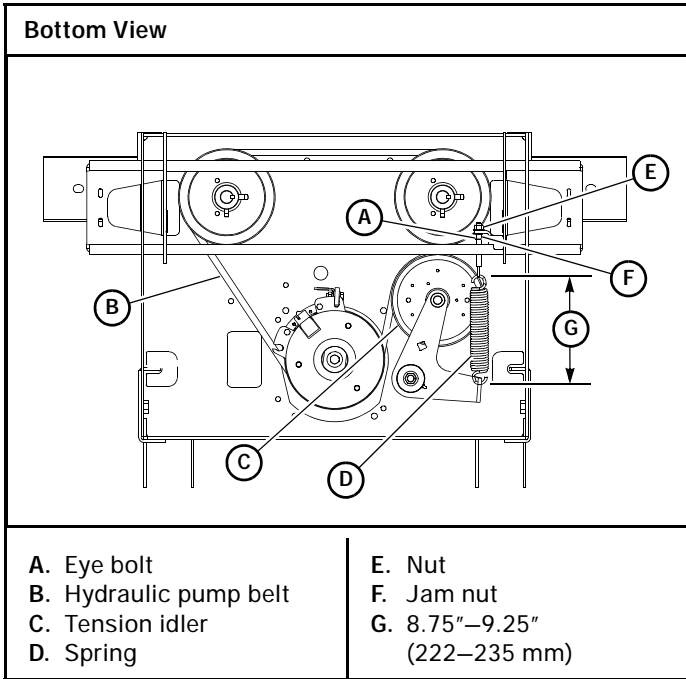

Figure 4-14

WARNING ⚠ Hydraulic fluid escaping under pressure may have sufficient force to penetrate skin and cause serious injury. Foreign fluid injected into the skin must be surgically removed within a few hours by a doctor, familiar with this form of injury, or gangrene may result.

⚠ Before applying pressure to hydraulic system, make sure all connections are tight and all hoses and lines are in good condition. To find a leak under pressure, use a piece of cardboard or wood — never use your hands. Relieve all pressure in the system before disconnecting or working on hydraulic lines. To relieve pressure, lower all attachments and shut off engine.

Change hydraulic system filter element and oil after first 50 hours of mower operation, then replace filter and oil in reservoir **annually or every 500 hours** whichever comes first.

IMPORTANT: It is necessary to drain the system oil from the hydraulic reservoir, using the reservoir drain plug, before removing the hydraulic filter. Replace the drain plug before adding system oil.

The Super 104™ hydraulic system filter is located inside the hydraulic reservoir on the underneath side of the tank. Use a Hustler® approved filter element only. When changing the filter use a 15/16" socket. The threads are right hand. Figure 4-16

Checking the Deck Lift Circuit Pressure

Equipment Required:

Hustler® Pressure Test Gauge Kit, part number 601661 or Gauge, part number 607464

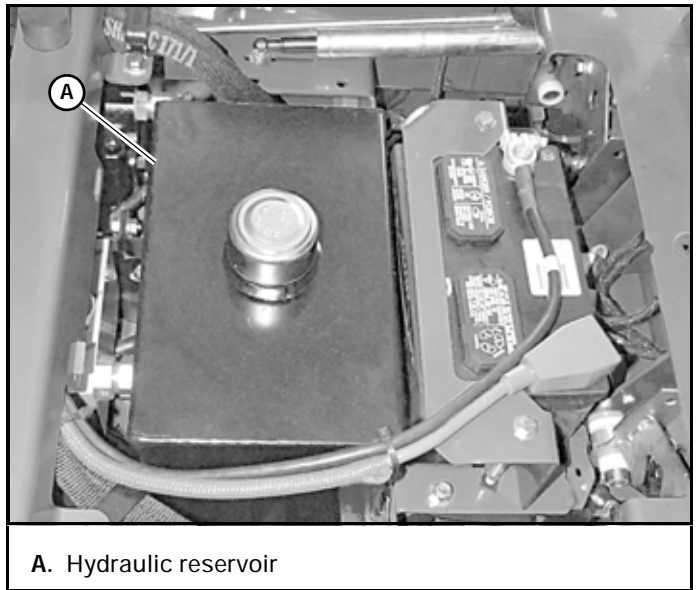

Figure 4-15

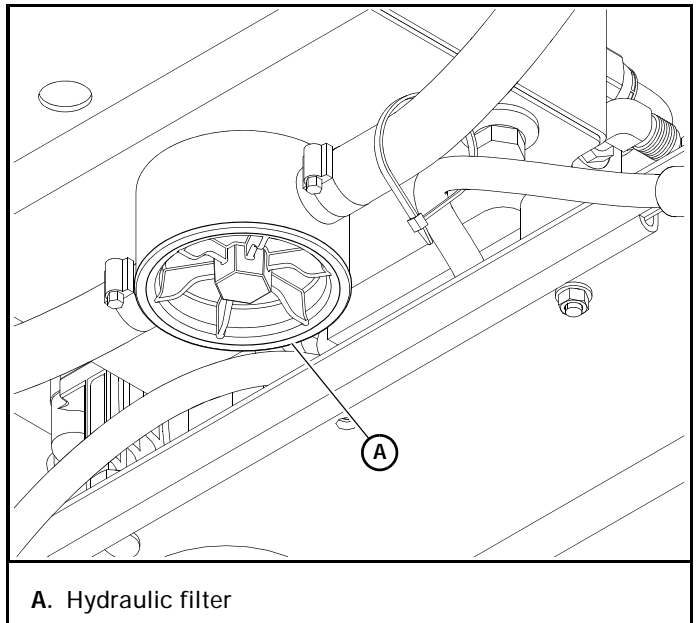

Figure 4-16

NOTE: If Pressure Test Gauge Kit (601661) is not available use Gauge (607464).

Use this procedure when checking the relief setting of the deck lift circuit.

1. With an operator on the seat, place the steering control levers in the park brake position, start the engine, and lower the main deck and side decks.
2. Shut the engine off.
3. Place an oil pan under the hydraulic lift manifold block.
4. With an operator on the seat, start the engine, and cycle the side decks up and down several times to bleed the air from the system. Shut the engine off.
5. Remove the gauge port cap at the rear of the hydraulic lift manifold block. Figure 4-17

6. Select the proper hose and 2000 psi gauge from the Pressure Test Gauge Kit (601661) or Gauge (607464). Attach the gauge to the hose. Attach the hose to the gauge port. Figure 4-18 & Figure 4-19
7. Set the throttle to full throttle and hold the side deck lift switch in the down position and read the gauge. The system pressure should read 800 psi. Figure 4-19
8. If the pressure is not at 800 psi, loosen the jam nut, and turn the relief valve the proper direction until 800 psi is reached. When the correct pressure is reached, tighten the jam nut. Figure 4-20
9. Shut the engine off.
10. Disconnect the hose and gauge and screw the gauge port cap back onto the gauge port and tighten. Figure 4-17
11. Remove the oil pan.
12. Clean up any oil spill.
13. Top off the hydraulic oil reservoir as needed.

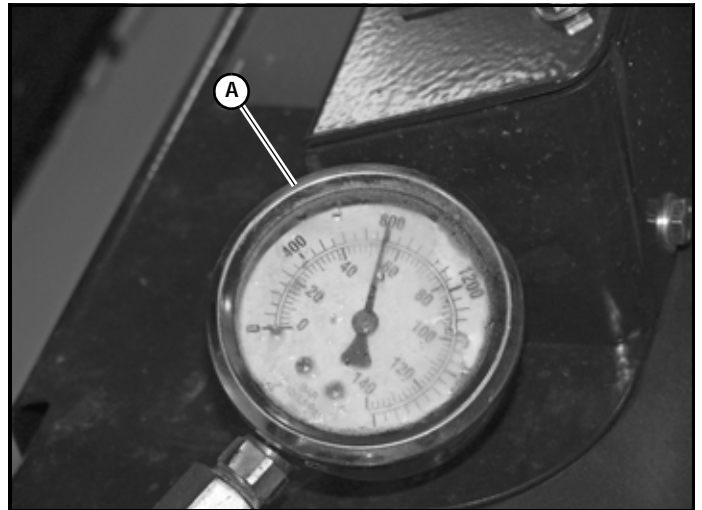

A. Pressure gauge showing 800 psi

Figure 4-19

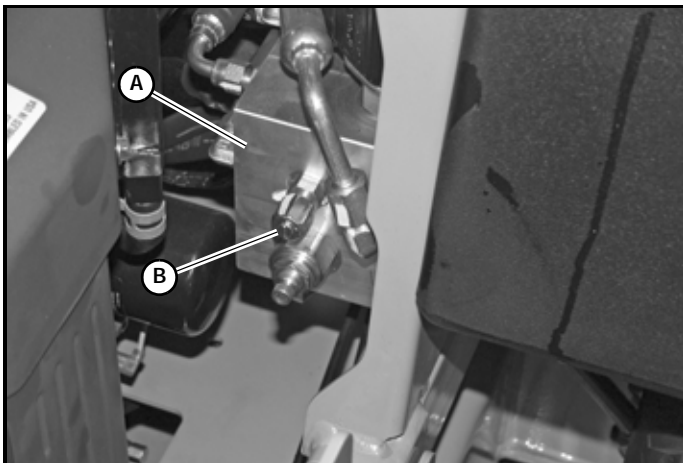

A. Hydraulic lift manifold block
B. Gauge port cap

Figure 4-17

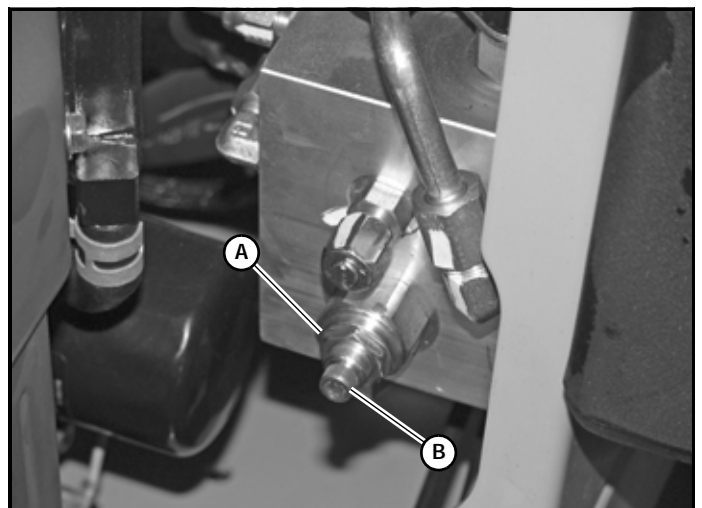

A. Jam nut B. Relief valve

Figure 4-20

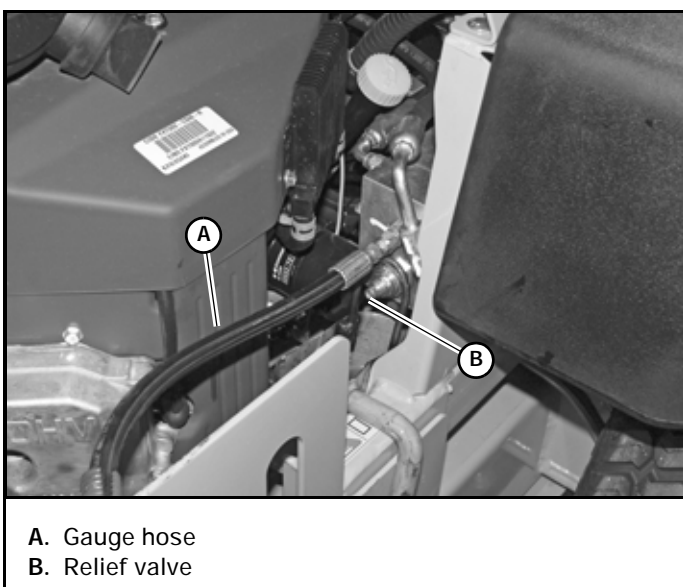

A. Gauge hose
B. Relief valve

Figure 4-18

Test Procedure for DDC20 Pump

Equipment Required

Hustler® Pressure Test Gauge Kit, part number 007898

Pump Test Procedure:

WARNING This procedure will require that the unit to be raised and blocked up off of the ground. It is necessary for the wheels to rotate without coming in contact with the floor or any object that would permit the unit to propel itself. Stay clear and exercise caution when rotating wheels to prevent injury. Use only appropriate vehicle stands, with a minimum weight rating of 2000 pounds to block the unit up. Use in pairs only. Follow the instructions supplied with the vehicle stands.

WARNING Untrained service personnel should never attempt to make any adjustments or repairs to the mower's drive system while the engine is running. **The following procedures should be performed by trained service personnel only.**

The drive system of this mower consists of two independent pump/motor combinations and will need to be tested separately. The oil supply (reservoir), filtering system (located in the bottom of the reservoir) and oil cooler are shared between the two independent systems. The testing sequence below is testing the hydrostatic pumps (only). If the test shows satisfactory results but performance is still deemed unacceptable, the motors, filtering, oil cooler and reservoir should be inspected.

1. Raise the rear of the mower and block with certified jack stands. The rear wheels need to be able to rotate freely and clear of all obstructions.
2. Check the front tires.
3. Raise the seat platform and disconnect the mower harness from the seat switch. Bypass the seat switch by connecting the two mower harness female spade connectors together. Figure 4-21

NOTE: Remove the tire and wheel assembly.

4. Clean hydraulic oil lines connecting to motor thoroughly. (Contamination allowed to enter in the hydrostatic system can cause pump and motor failures).
5. After cleaning, remove oil supply lines from the motor and loosen supply lines at the pump. One wheel motor fitting may need to be removed to assist with test line installation. Cap the wheel motor ports or fittings.
6. Test procedures are the same for both the right and left sides.
7. Install Hustler® Test Gauge Kit (p/n 007898) as shown in Figure 4-22 and Figure 4-23. Check the bypass valve (tow valve) to make sure it is fully seated. Figure 4-24

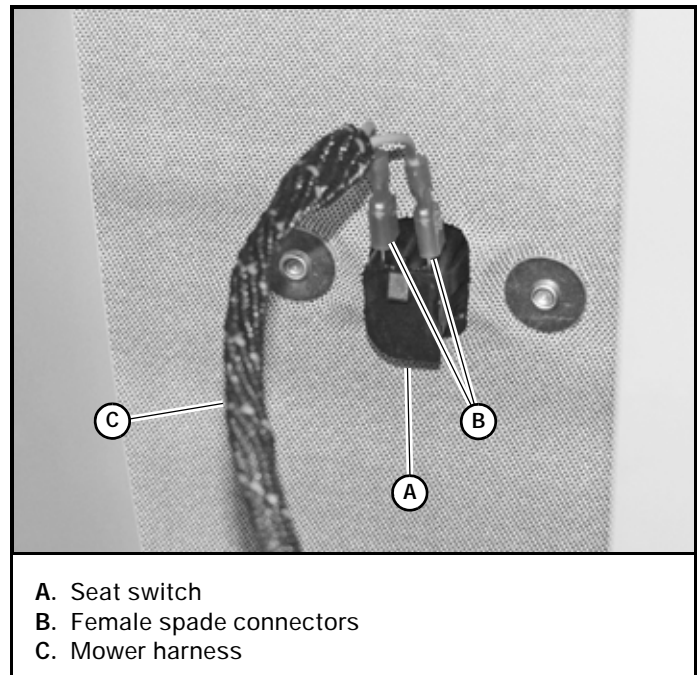

Figure 4-21

8. Recheck hose and fittings to make sure they are tight.
9. Check oil reservoir for proper oil level and make sure hydraulic filter is in good condition.

WARNING Hydraulic fluid escaping under pressure may have sufficient force to penetrate skin and cause serious injury. Foreign fluid injected into the skin must be surgically removed within a few hours by a doctor, familiar with this form of injury, or gangrene may result.

Before applying pressure to hydraulic system, make sure all connections are tight and all hoses and lines are in good condition. To find a leak under pressure, use a piece of cardboard or wood — never use your hands. Relieve all pressure in the system before disconnecting or working on hydraulic lines. To relieve pressure, lower all attachments and shut off engine.

10. Run engine at mid throttle for one or two minutes or until top of pump is warm to the touch.
11. **Increase engine speed to full throttle.**
12. Slowly move the steering control lever forward. You should easily get a 2600 PSI reading from one of the gauges. Return steering control lever to neutral.

(Caution: Do not hold steering control lever in forward position for more than 10 seconds as oil will become extremely hot).

Then, slowly move steering control lever in reverse. You should easily get a 2600 PSI reading from the other gauge.

(Caution: Do not hold steering control lever in rearward position for more than 10 seconds as oil will become extremely hot).

If pressure is less than 2600 PSI, causes are: internal relief valve is faulty or internal pump parts are damaged.

IMPORTANT: Anytime a hydraulic pump is replaced the drive motor, hydraulic lines and oil cooler must be inspected and cleaned or replaced due to possible contamination.

After testing is concluded:

1. **IMPORTANT:** With the engine off, disconnect the two female spade connectors from each other (from step #3) and reconnect them to the seat switch. This must be completed so that the safety circuit is functioning properly. Figure 4-21

WARNING Do not operate the mower without plugging the mower's wiring harness into the seat switch. This switch is an important part of the safety start interlock system. Serious injury can result if the seat switch is not plugged into the mower's wiring harness.

WARNING Never operate the mower with a non-functioning seat switch. Always reconnect the seat switch to the mower harness.

2. Remove the Hustler® Pressure Test Gauge Kit.
3. After all repairs are completed, check to make sure all tools and obstructions are removed from under the mower.
4. Raise the rear of the mower and remove the jack stands. Lower the mower.
5. Lower and secure the seat platform.

New or Rebuilt DDC20 Pump Startup Procedure

NOTE: Use this startup procedure any time a DDC20 pump has been removed for service or replaced.

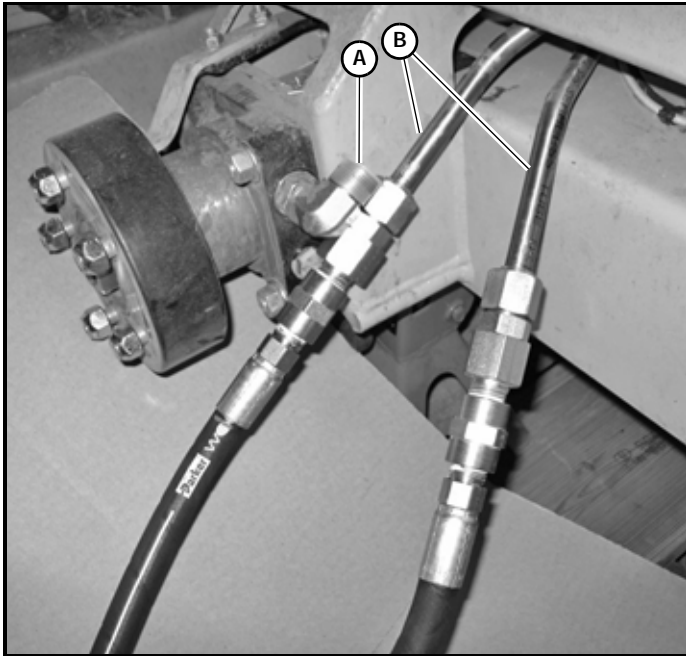

A. Cap fitting B. Supply lines

Figure 4-22

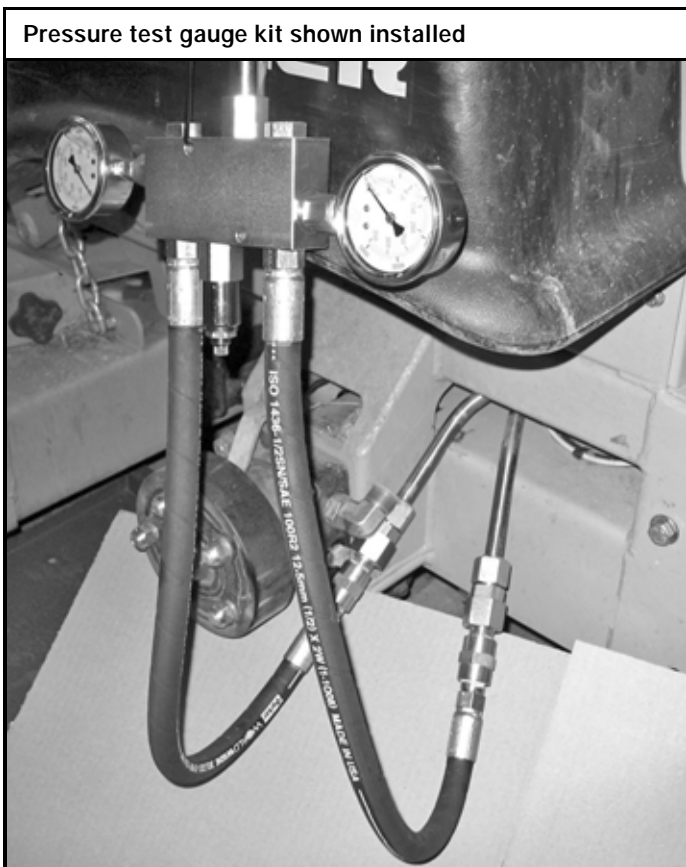

Figure 4-23

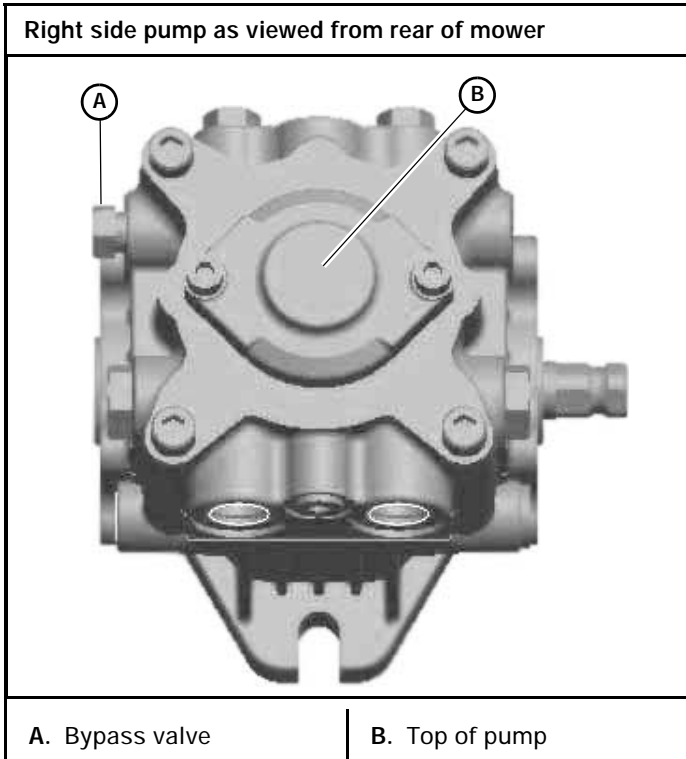

Figure 4-24

Pump Replacement:

WARNING ⚠ This procedure will require that the unit to be raised and blocked up off of the ground. It is necessary for the wheels to rotate without coming in contact with the floor or any object that would permit the unit to propel itself. Stay clear and exercise caution when rotating wheels to prevent injury. Use only appropriate vehicle stands, with a minimum weight rating of 2000 pounds to block the unit up. Use in pairs only. Follow the instructions supplied with the vehicle stands.

WARNING ⚠ Untrained maintenance personnel should never attempt to make any adjustments or repairs to the mower's drive system while the engine is running. **The following procedures should be performed by trained maintenance personnel only.**

1. Raise the rear of the mower and block with certified jack stands. The rear wheels need to be able to rotate freely and clear of all obstructions.
2. Chock the front tires.
3. Raise the seat platform and disconnect the mower harness from the seat switch. Bypass the seat switch by connecting the two mower harness female spade connectors together. Figure 4-25
4. Before installing pump on machine, (either new or rebuilt) fill pump case with fresh, clean oil by removing case drain plug and add 6 - 8 oz. of 15W50 synthetic

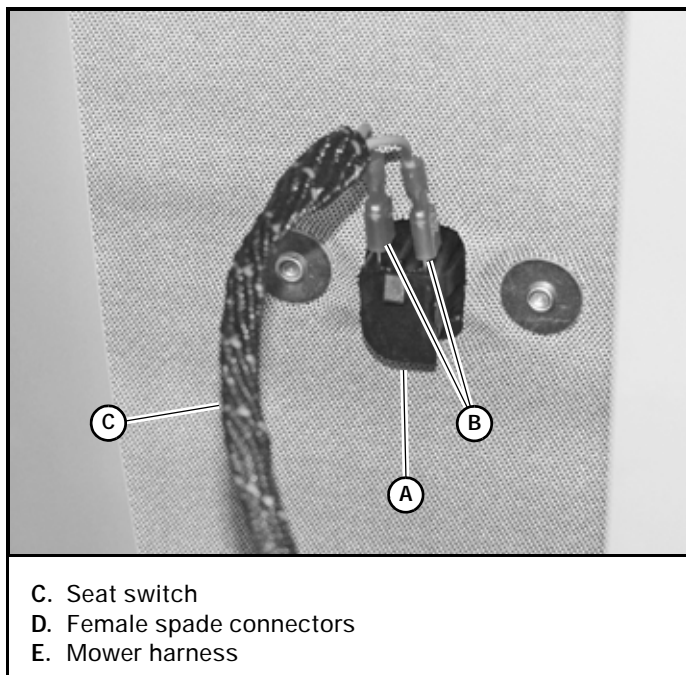

Figure 4-25

oil or 20W50 synthetic oil (Hustler® Full Synthetic 20W50 Hydrostatic Transmission Oil is recommended), then install the hose fitting. Figure 4-26

5. Install pump on machine and install lines.
6. **Left Side Pump Replacement Only** – Install the Super 104™ Filter Flush Kit (part number 122756) per the kit instructions. Install the lower implement circuit gauge kit (part number 607464). **Do not** follow the flushing procedures in the instructions at this time.
7. Check reservoir for contamination, metal particles, dirt, water, etc. and clean if necessary. Replace hydraulic filter and fill reservoir with oil until it is just below the reservoir neck.
8. **Do not** open tow valves.
9. Place the steering control levers in the neutral position.
10. Set engine throttle to the half throttle position.
11. Start engine. Run at idle for 30 seconds.
12. Stroke steering control lever to the forward position.

NOTE: If wheel motor does not rotate in 15 seconds, return steering control lever to neutral and shut off engine. Check hydraulic oil level and replenish if needed. Repeat steps 8 through 11.
13. After wheel motor starts to rotate, increase engine speed to half throttle and stroke the steering control lever forward and reverse several times until the wheel motor operates smoothly through the entire speed range.

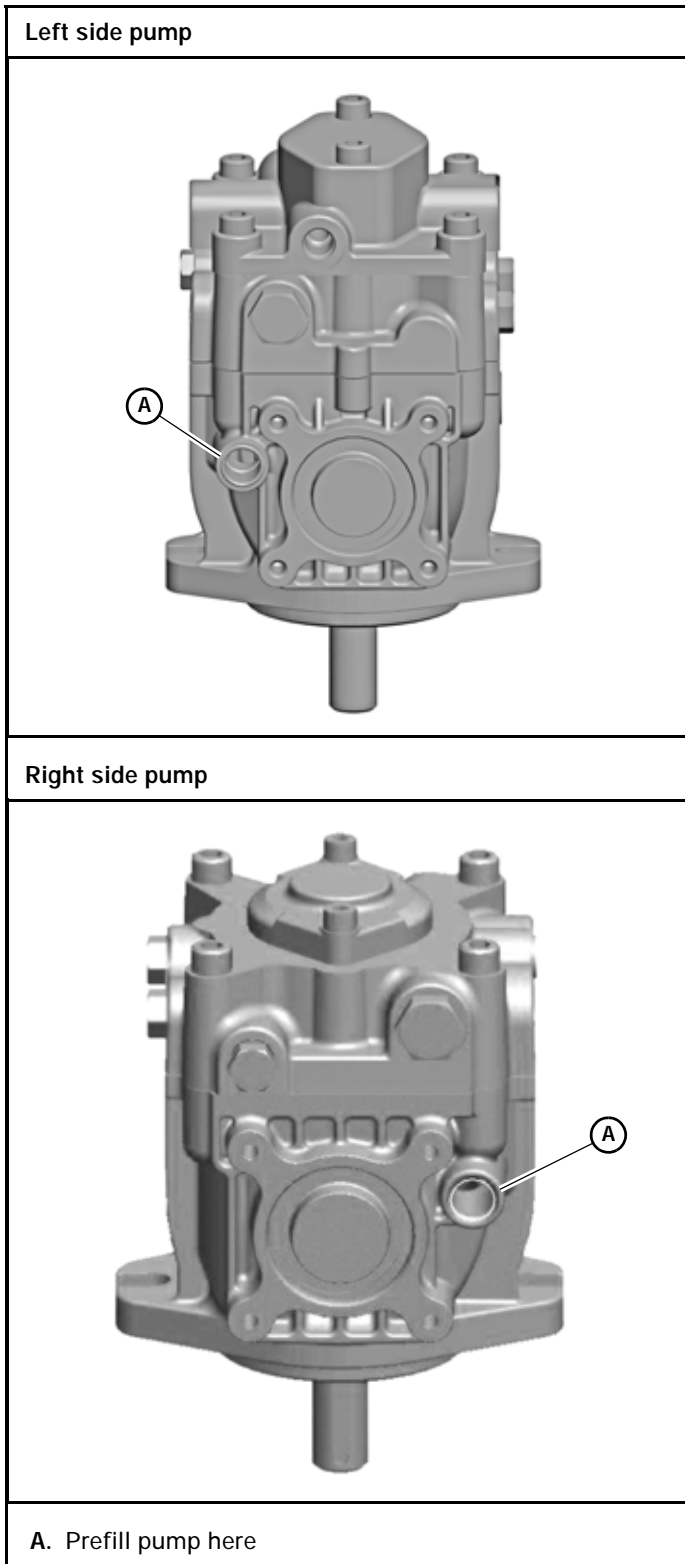

Figure 4-26

14. **Left Side Pump Replacement Only** – Follow the flushing procedures outlined in the Super 104™ Filter Flush Kit (122756) instructions.
15. **IMPORTANT:** With the engine off, disconnect the two female spade connectors from each other (from step #3) and reconnect them to the seat switch. This must be completed so that the safety circuit is functioning properly. Figure 4-26

WARNING ⚠ Do not operate the mower without plugging the mower's wiring harness into the seat switch. This switch is an important part of the safety start interlock system. Serious injury can result if the seat switch is not plugged into the mower's wiring harness.

WARNING ⚠ Never operate the mower with a non-functioning seat switch. Always reconnect the seat switch to the mower harness.

16. Check to make sure all tools or obstructions are removed from under the mower.
17. Raise the rear of the mower and remove the jack stands. Lower the mower.
18. Lower and secure the seat platform.

Warner Clutch Re-gap Adjustment Procedures

The air gap is only adjustable on clutches that have a removable shim (see Figure 4-31).

When to remove shim:

When a clutch has worn to the extent that the existing air-gap is too large to allow for complete clutch engagement (clutch may engage easily when cold but has problems engaging when hot), the brake shim can be removed to reduce air gap and allow the clutch to continue to function.

After verifying that proper voltage and current are supplied to the clutch, follow the procedure outlined below.

NOTE: Before proceeding, the clutch must be installed on the engine crankshaft and the retaining bolt torqued to 45–48 ft-lbs (61–65 N•m).

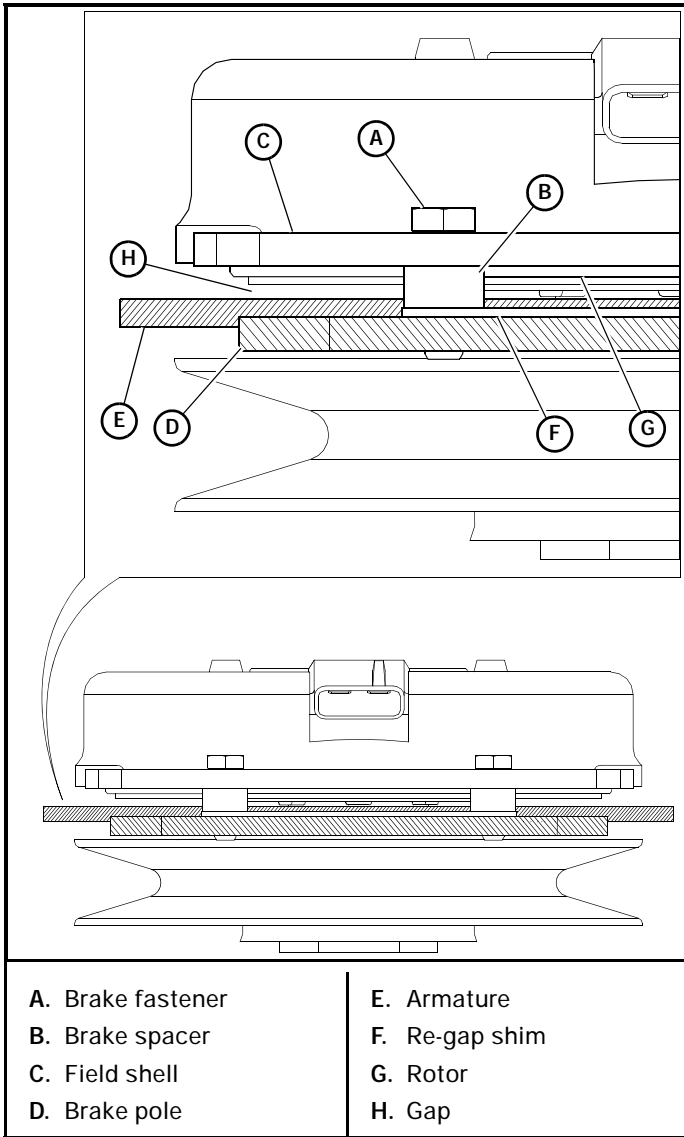

Figure 4-27

Procedure:

WARNING ⚠️ Always wear adequate eye protection when servicing the mower.

With engine off, key removed and clutch disengaged and using a pneumatic line, blow out any debris from under the brake pole and around the aluminum spacers. Figure 4-28

Check the air gap between rotor & armature with feeler gage. If the gap is less than .070", then follow the troubleshooting procedure outlined in Warner Electric P1177 installation troubleshooting guide available on Warner Electric's web site, www.warnerelectric.com. If the air gap is over .070", follow the procedure outlined below. Figure 4-29

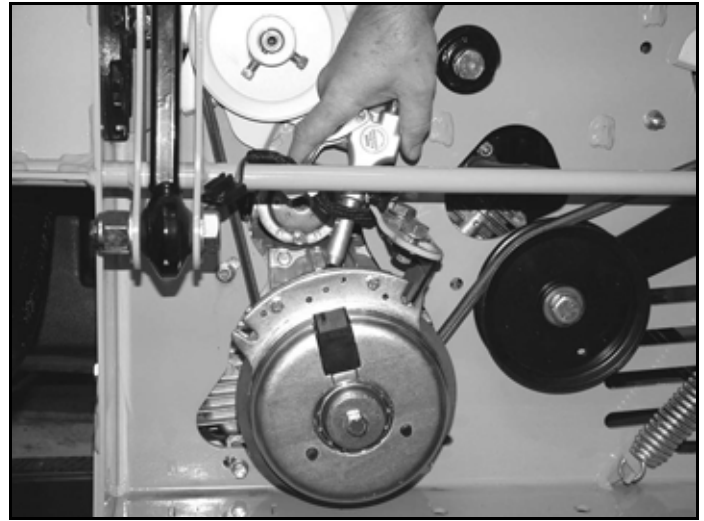
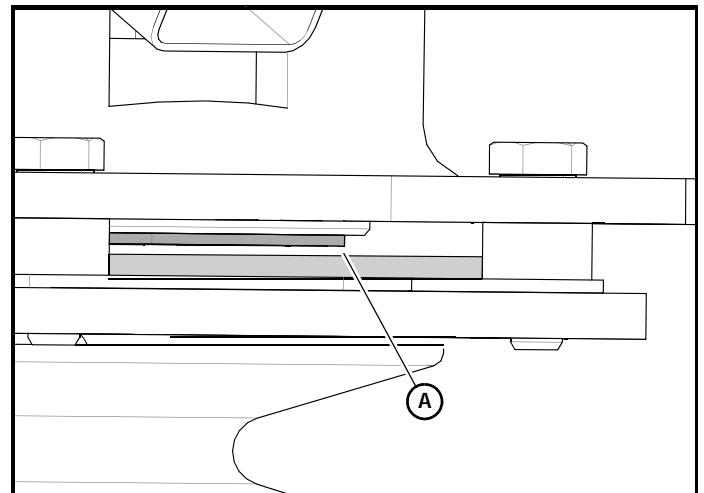

Figure 4-28



A. Gap between the rotor and armature face must be greater than .070" prior to shim removal.

Figure 4-29

1. Loosen both brake mounting bolts 1/2 to 1 full turn as shown in Figure 4-30.

WARNING ⚠️ Do not remove brake pole from field shell/armature. The brake pole tracks match with the clutch brake and need to continue to match after shim is removed to ensure proper brake torque. Figure 4-27

2. Using needle nose pliers, or by hand, take hold of the tab and remove shim (do not discard shim until proper clutch function has been confirmed). Figure 4-31
3. Using a pneumatic line, blow out any debris from under the brake pole and around the aluminum spacers. Figure 4-28
4. Re-torque each bolt (M6 X 1) to 120 in.-lbs (13.5 N·m).

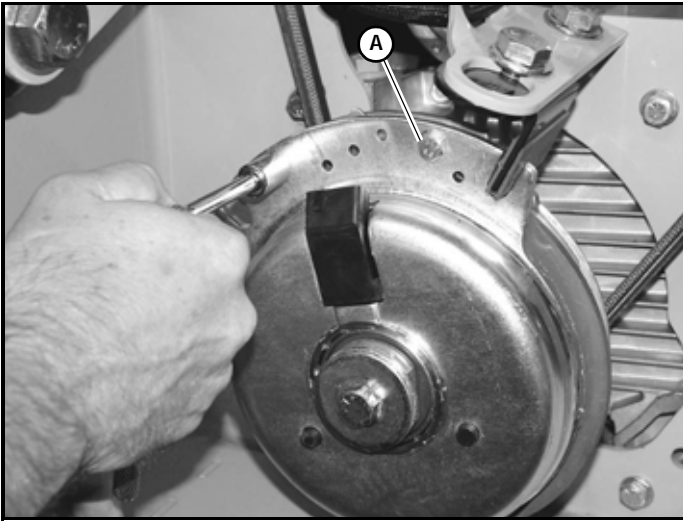

A. M6 x 1 bolt

Figure 4-30

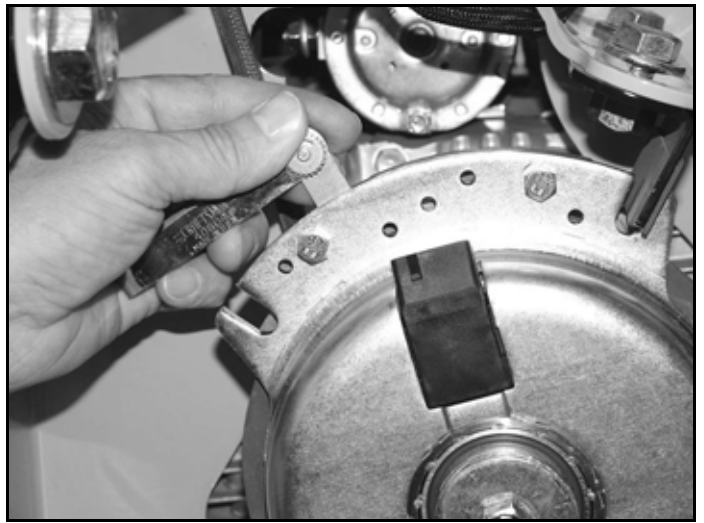

Figure 4-32

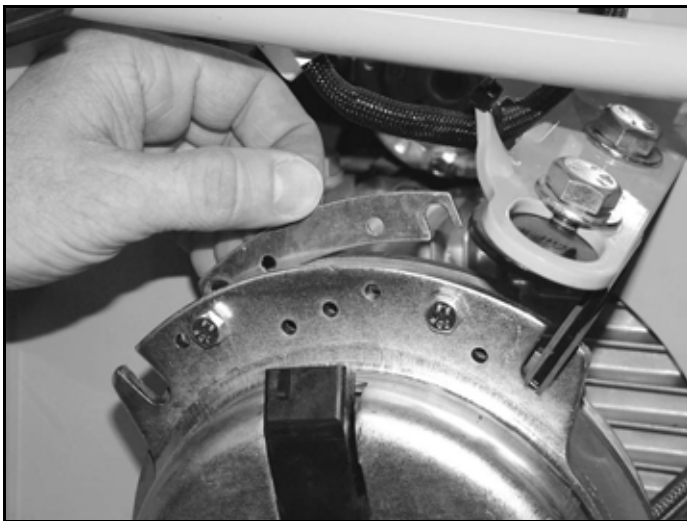

Figure 4-31



Figure 4-33

5. Using a .015" thick feeler gage, verify that a gap is present between the rotor and armature face on both ends of the brake pole as shown. Figure 4-32 and Figure 4-33
 - a. If the gap is less than .015" the clutch must be replaced.
 - b. If sufficient gap is present, then proceed to safety check outlined below.

Perform Safety Check:

WARNING	<p>Observe deck operation from the operator's seat.</p>
----------------	---

1. Start the engine and the deck should not be engaged with the PTO switch "off" and clutch de-energized. Engage and disengage the PTO switch to ensure the proper function of the clutch.
2. If clutch still does not engage, then follow the troubleshooting procedure outlined in Warner Electric P1177 installation troubleshooting guide available on Warner Electric's web site, www.Warnerelectric.com and consult owner's manual.

Caster Fork Tapered Bearings Replacement

NOTE: A 1/4"–28 straight thread zerk fitting (not provided) is required for replacing the grease.

Disassembly:

1. Raise the front of the mower enough to remove the caster wheel assembly.
2. Place mower securely on jack stands and do not allow mower to move. Chock the drive wheels.

WARNING

- Use only certified jack stands.
- Use only appropriate jack stands, with a minimum weight rating of 2000 pounds (907 kg) to block the unit up.
- Use in pairs only.
- Follow the instructions supplied with the jack stands.

3. Remove the top cap and the top lock nut. Figure 4-34
4. Remove the caster fork from the machine.
5. Remove and retain the cup washers.
6. Remove and discard the seal.
7. Remove and discard the tapered roller bearings and outer races.
8. Remove and retain the grease port plug.

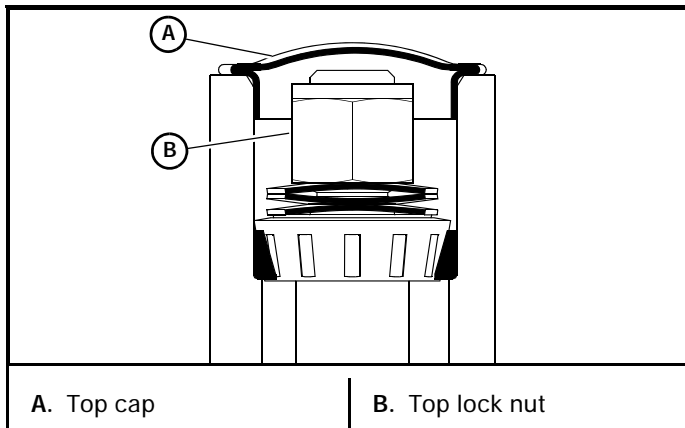

Figure 4-34

Assembly:

1. Insert the 1/4"–28 straight thread zerk fitting into the grease port and tighten.
2. Apply a light coating of grease to the caster pocket before installing the outer bearing races.
3. Use the Hustler® Bearing Race Installation Kit (p/n 124351) to install the outer races into the caster pocket bore.
4. Insert the Bearing Race Installation tool through the backing plate and the caster arm housing.

5. Align a bearing outer race over the Bearing Race Installation tool and into the caster arm housing. Make sure that the race's thick edge is the leading edge going into the caster arm housing.

IMPORTANT: Do not use the bearings to press the races into place.

6. Install the pressing tool, washers and the nut, then slowly start to draw the race into the caster arm housing.
7. Make sure the bearings outer race is correctly aligned before pressing the outer race into the fully-seated position against the caster pocket shoulder. Figure 4-35

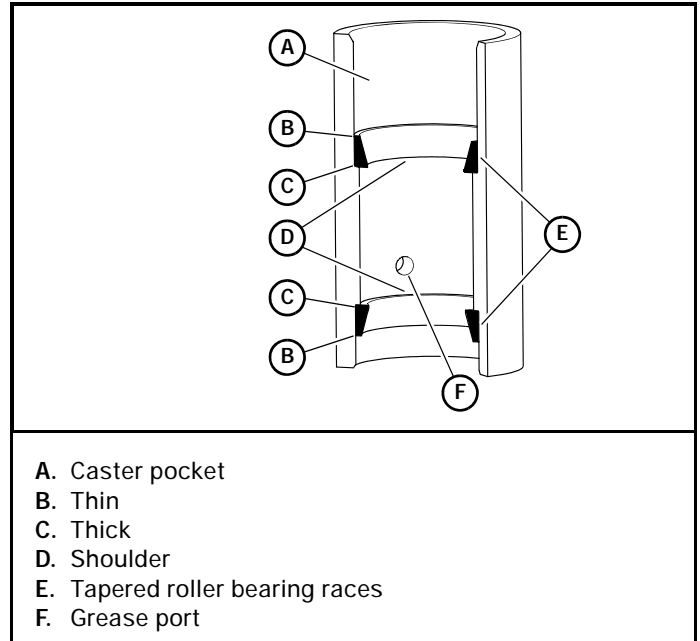

- A. Caster pocket
- B. Thin
- C. Thick
- D. Shoulder
- E. Tapered roller bearing races
- F. Grease port

Figure 4-35

8. Disassemble and invert the Bearing Race Installation tool to install the other outer race.
9. Install the bottom bearing and lower seal. Make sure that the lower seal lip is facing out and driven flush with the caster pocket. Figure 4-36

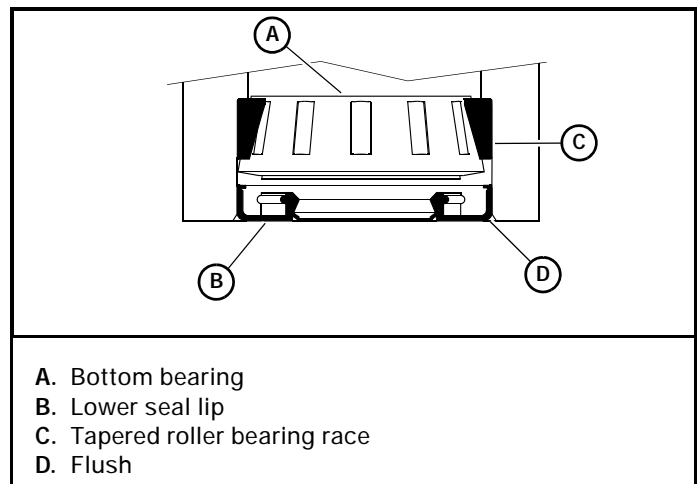

- A. Bottom bearing
- B. Lower seal lip
- C. Tapered roller bearing race
- D. Flush

Figure 4-36

10. Install the upper bearing. Figure 4-37

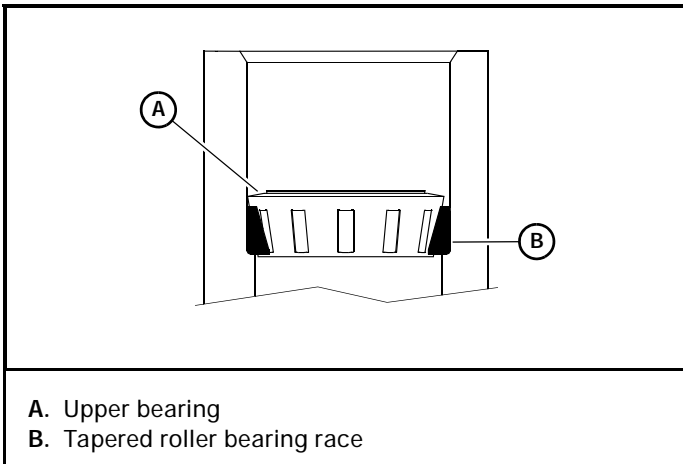

Figure 4-37

11. Install the caster fork assembly, taking care not to damage the lower seal lip. Figure 4-36

IMPORTANT: Stack the cup washers as shown in Figure 4-38.

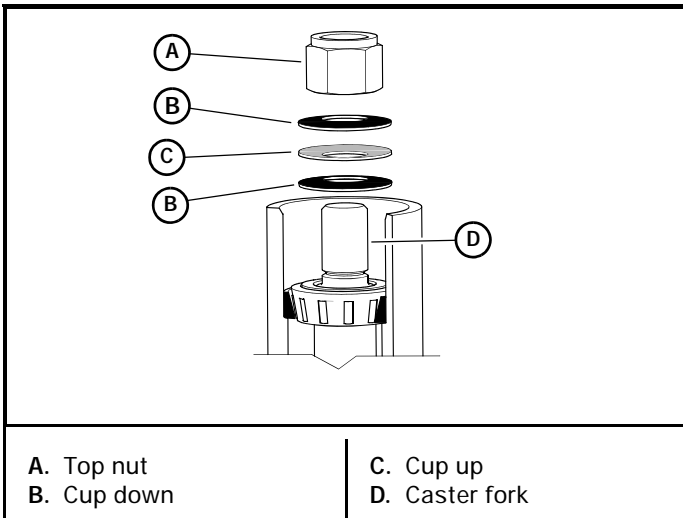

Figure 4-38

12. Torque the top nut to 40 ft-lbs (55 N•m), then back off ¼ turn. Figure 4-38
13. Apply grease to the grease zerk until it is visible at the top bearing. Fill the top cavity with grease.
14. Make sure that the caster fork is free to rotate by spinning the fork one full revolution.
15. Remove the grease zerk, insert the plug into the grease port and tighten.
16. Install the top cap.
17. Remove the jack stands and wheel chocks.

Tapered Wheel Bearing Replacement

Disassembly:

1. Raise the front of the mower enough to remove the wheel assembly.

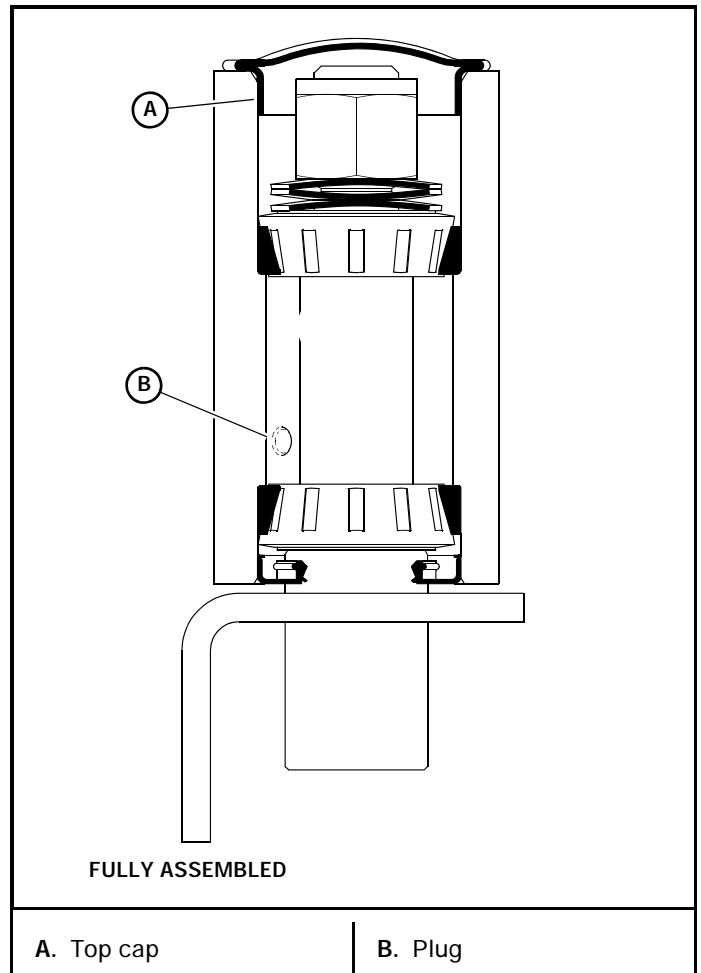

Figure 4-39

2. Place mower securely on jack stands and do not allow the mower to move. Chock the drive wheels.



WARNING

- Use only certified jack stands. Use only appropriate jack stands, with a minimum weight rating of 2000 pounds (907 kg) to block the unit up.
- Use in pairs only.
- Follow the instructions supplied with the jack stands.

3. Remove the wheel from the fork by removing the axle bolt, flat washers, and lock nut. Figure 4-40
4. Remove the dust caps and bushings from the wheel housing. Retain these parts. Figure 4-41
5. Remove and discard the seals. Figure 4-41
6. Remove and discard the tapered roller bearings and outer bearing races. Figure 4-41
7. To prevent contamination of the new tapered roller bearings remove the existing grease from the wheel housing.

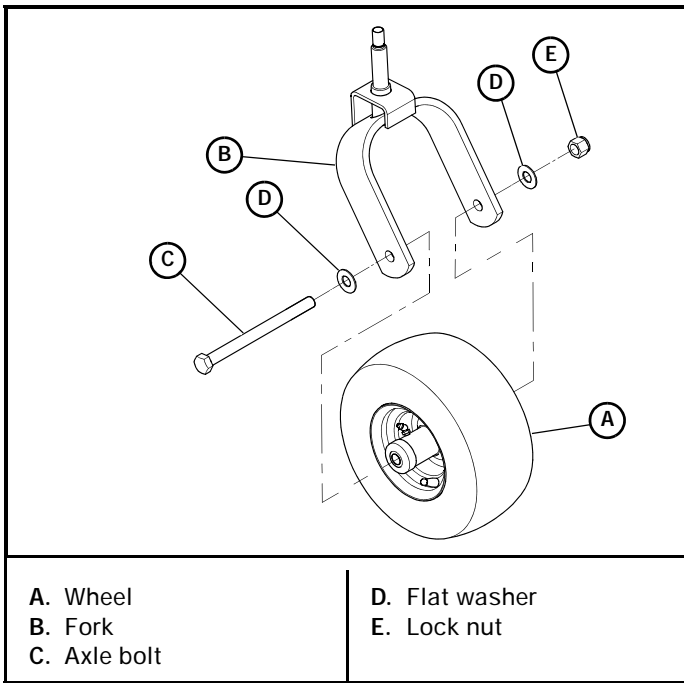

Figure 4-40

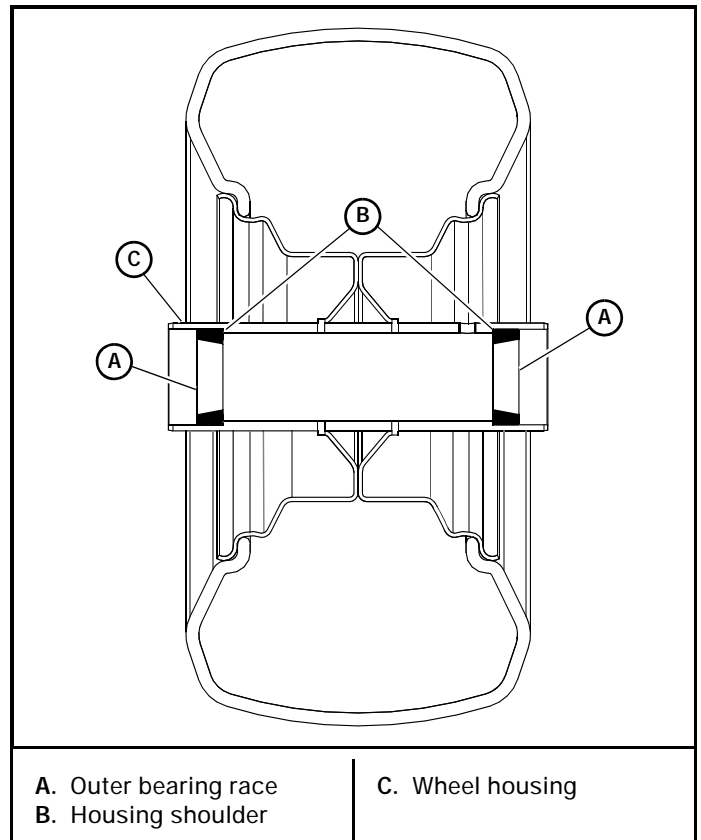

Figure 4-42

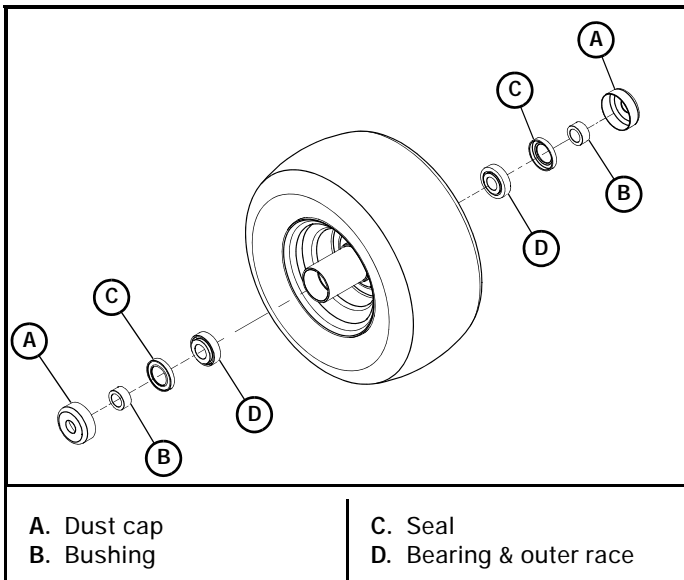

Figure 4-41

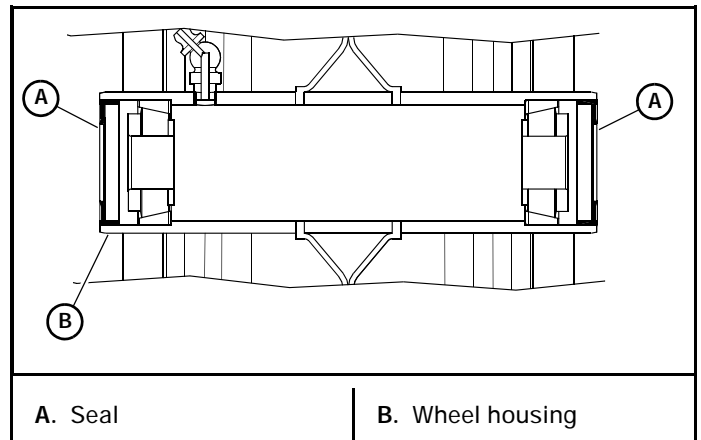

Figure 4-43

Assembly

1. Press the new outer bearing races into the wheel housing until they are fully seated against the housing shoulder. Figure 4-42
2. Thoroughly pack the tapered roller bearings with multi-purpose grease.
3. Insert the new tapered roller bearings into the outer bearing race. Figure 4-43
4. Insert the new seals into the wheel housing. Make sure that the flat side of the seal is flush with the outside edge of the wheel housing. Figure 4-43
5. Insert the bushings through the seal openings and push them in until they contact the tapered roller bearings. Figure 4-44

6. Push the dust caps onto the wheel housing. Figure 4-44
 7. Slide the wheel assembly between the caster fork legs and assemble to the fork using the axle bolt, flat washers, and lock nut. Figure 4-45
- NOTE:** Make sure the head of the axle bolt is on the same side as the valve stem.
8. Screw the lock nut onto the axle bolt and tighten. Then, back the nut off until the wheel rotates freely.
 9. Using a grease gun, insert multi-purpose grease into the wheel housing until grease begins to seep from the dust caps.

Tires

It is important for level mowing that the tires have the same amount of air pressure. The recommended pressures are:

Drive wheels 15–20 psi (103–138 KPa)

Front wheels 20–25 psi (138–172 KPa)

If you wish to use non-pneumatic tires on your Hustler® mower, the tire must be a Hustler® approved tire. Warranty claims will be denied on any mower equipped with unapproved non-pneumatic tires.

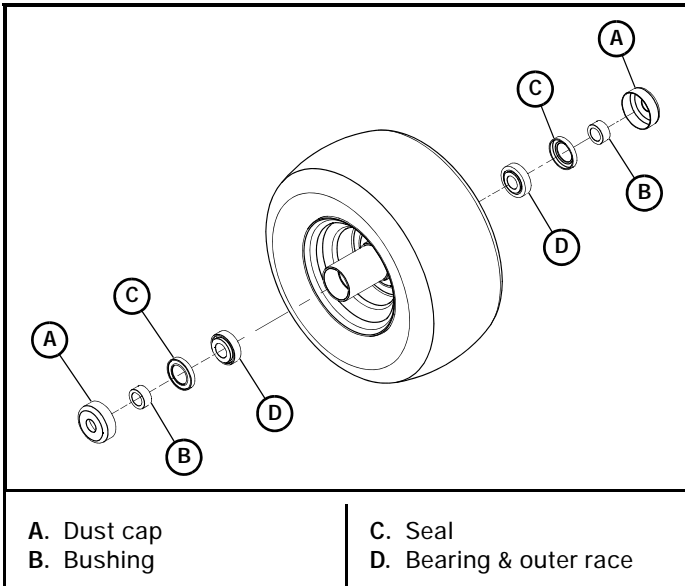

Figure 4-44

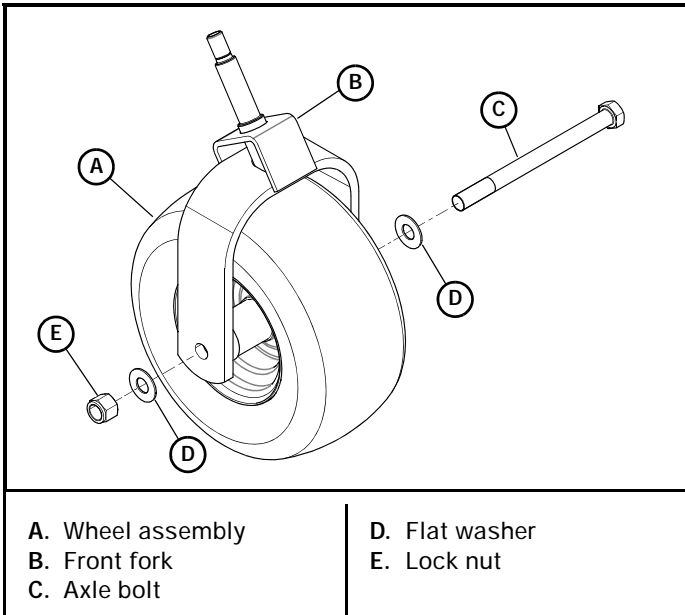

Figure 4-45

ENGINE MAINTENANCE

General Engine Maintenance

Detailed instructions and recommendations for break-in and regular maintenance are specified in the *Engine Owner's Manual*. Please refer to this manual for engine servicing, lubricating oil levels with quality and viscosity recommendations, bolt torques, etc. The engine warranty is backed by the engine manufacturer. Special attention should be paid to applicable data which will not be duplicated here.

Engine Oil and Filter



Allow the engine to cool before changing the engine oil. If the engine has been running, use caution when changing the engine oil as it will be very hot. You should wear the appropriate protective gear to avoid being burned or exposed to engine oil.

Check engine oil daily and after every 4 hours of operation. The machine must be sitting level when checking oil. Refer to engine manual and maintenance schedule for oil recommendation and capacities. Hustler® Motor Oil is recommended.

Change the engine oil and filter after the first 5 hours of operation and per the engine manufacturer's recommendations after that. If mower is being operated in extremely dirty conditions, then it is recommended oil be changed more frequently.

IMPORTANT: After the new oil filter has been installed, clean up any oil which may have spilled onto the engine plate, engine exhaust system, and muffler guard.

Vanguard, Vanguard EFI (without Oil Guard™ option) & Kawasaki engines — Draining the engine oil:

1. Locate the oil drain valve on the engine. Figure 5-1 and Figure 5-2
2. Position a suitable oil drain container under the machine below the oil drain valve.
3. Twist the valve counterclockwise to open the valve. Allow 10 minutes for engine oil to adequately drain.
4. After the oil is drained, close the valve by turning it clockwise.
5. Once the valve is closed, clean up any spilled oil.

IMPORTANT: All oil drips or spills **must** be cleaned off of the engine plate, engine exhaust system, and muffler guard before operating the machine.

Vanguard EFI Engine with Oil Guard™ — Draining the engine oil:

1. Locate the oil drain valve on the bottom of the oil tank. Figure 5-3

Vanguard engine (non EFI) shown

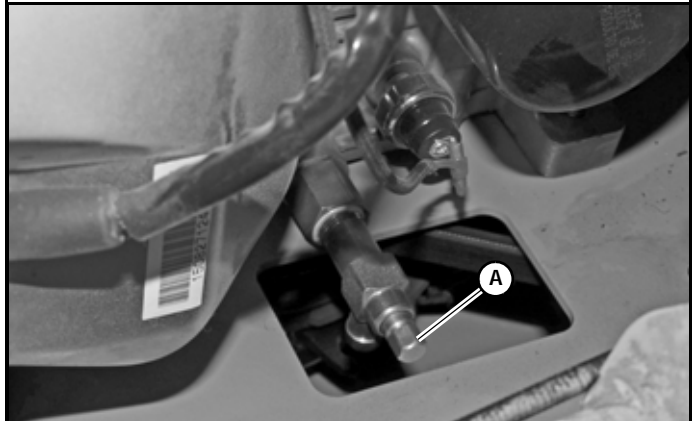

A. Oil drain valve

Figure 5-1

Kawasaki engine shown

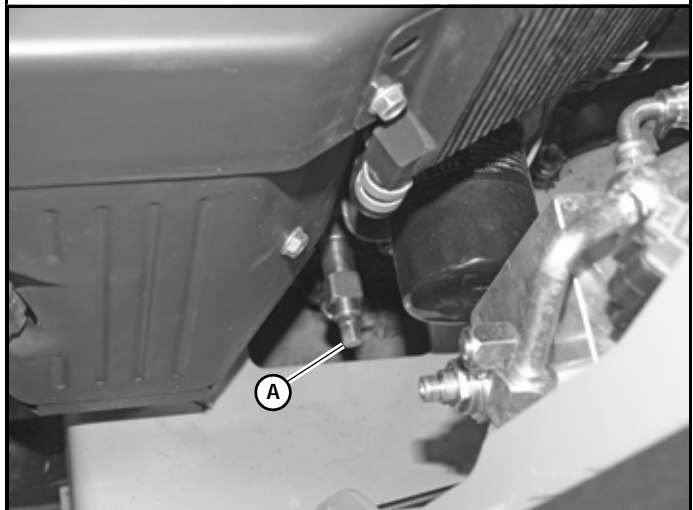

A. Oil drain valve

Figure 5-2

2. Locate the oil drain hose that was supplied with the machine. Be sure to clean and clear it of debris that might block the flow of the engine oil.
 3. Attach one end of the hose onto the oil drain valve nipple. Make sure the hose is pushed all the way onto the valve. Figure 5-3
 4. Position the loose end of the hose through the opening in the engine plate, so that it can drain into a suitable oil drain container.
- IMPORTANT:** Make sure the oil does not come in contact with the belts or clutch.
5. Position a suitable oil drain container under the machine below the end of the hose.

The safety element does not require servicing unless it becomes contaminated with dirt or moisture.

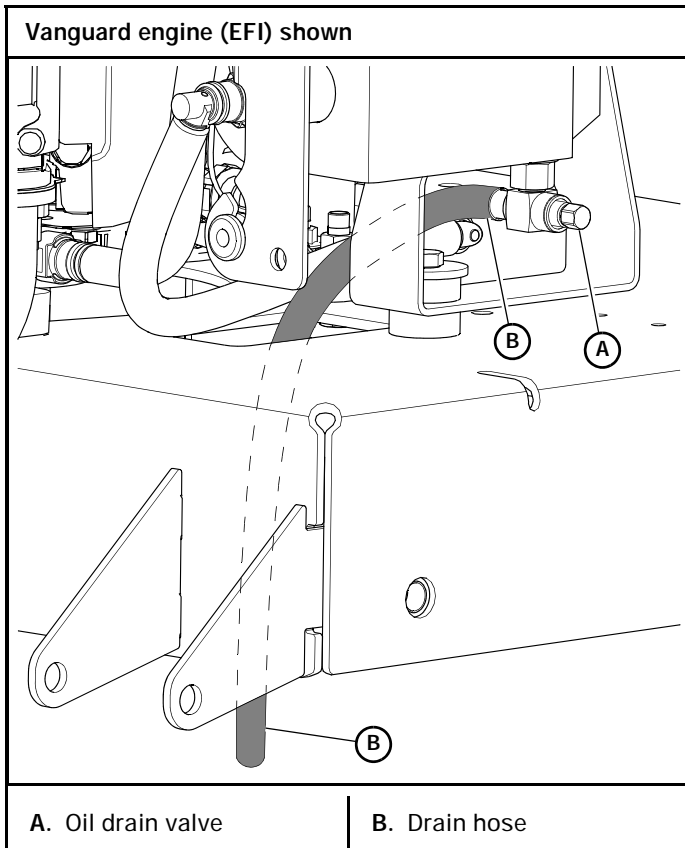

Figure 5-3

6. Use a 10 mm wrench or socket and open the valve approximately 4 turns in the counterclockwise direction. Allow 10 minutes for engine oil to adequately drain.
7. After the oil is drained, close the valve by twisting clockwise.
8. Once the valve is closed, carefully remove the oil drain hose and clean up any spilled oil.
IMPORTANT: All oil drips or spills **must** be cleaned off of the engine plate, engine exhaust system, and muffler guard before operating the machine.
9. Clean the oil drain hose and store it appropriately.

Engine Air Filter

Perform engine air filter maintenance per the *Maintenance Schedule* shown elsewhere in this manual.

A specially designed dry filter is standard equipment on these mowers and supplies clean combustion air to the engine. Figure 5-4, Figure 5-5, & Figure 5-6

These mowers are equipped with a safety filter. The filter element slides over the safety filter. Figure 5-8

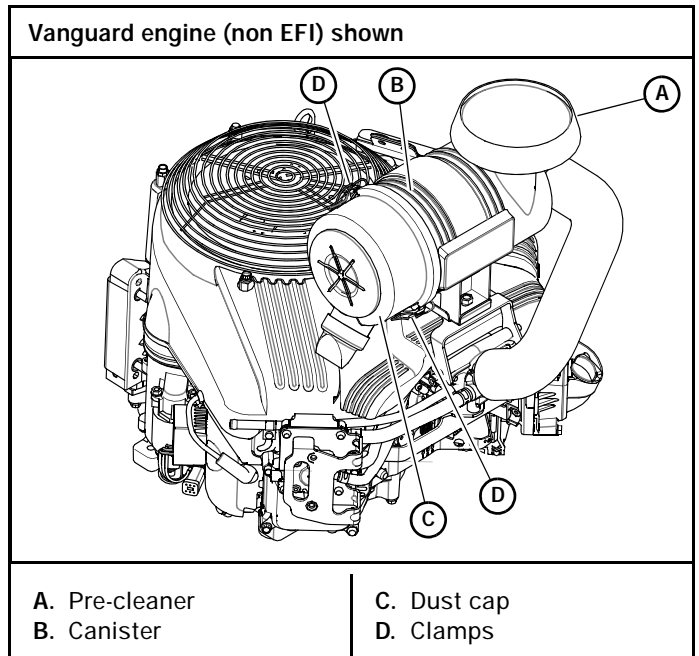

Figure 5-4

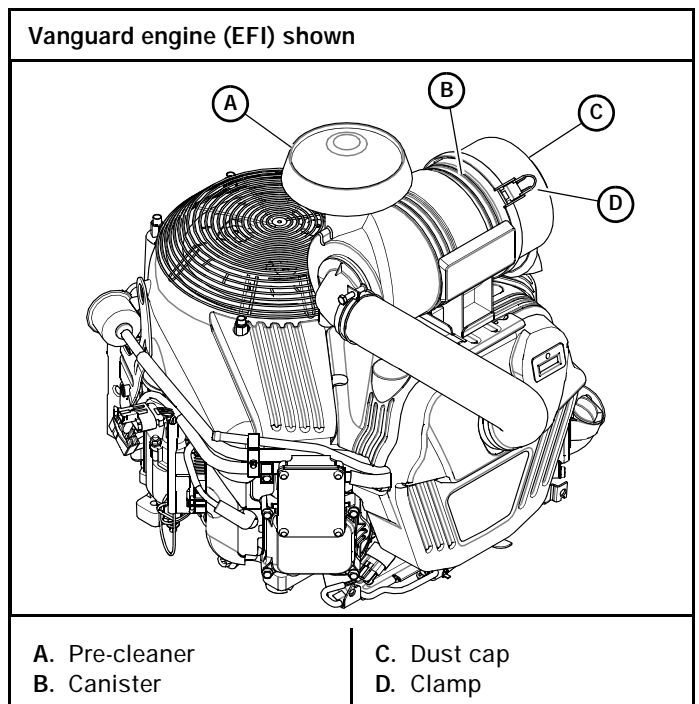

Figure 5-5

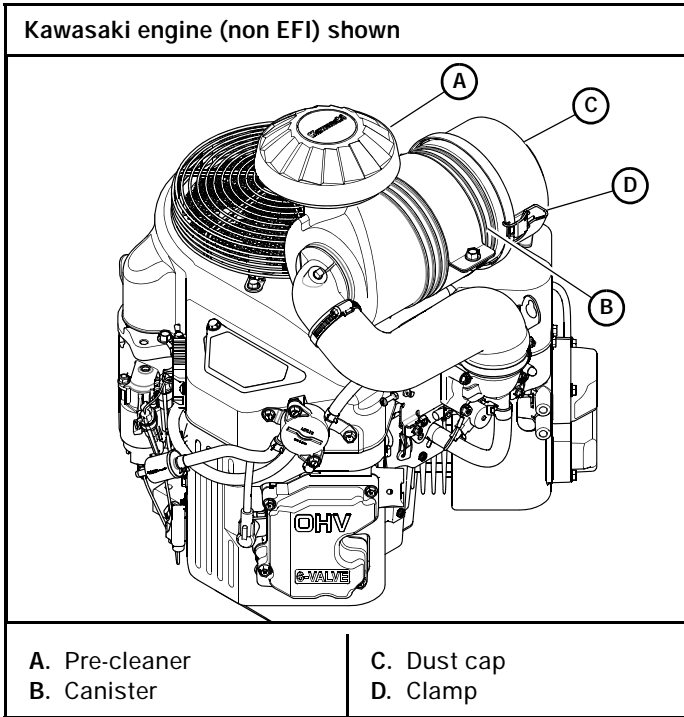

Figure 5-6

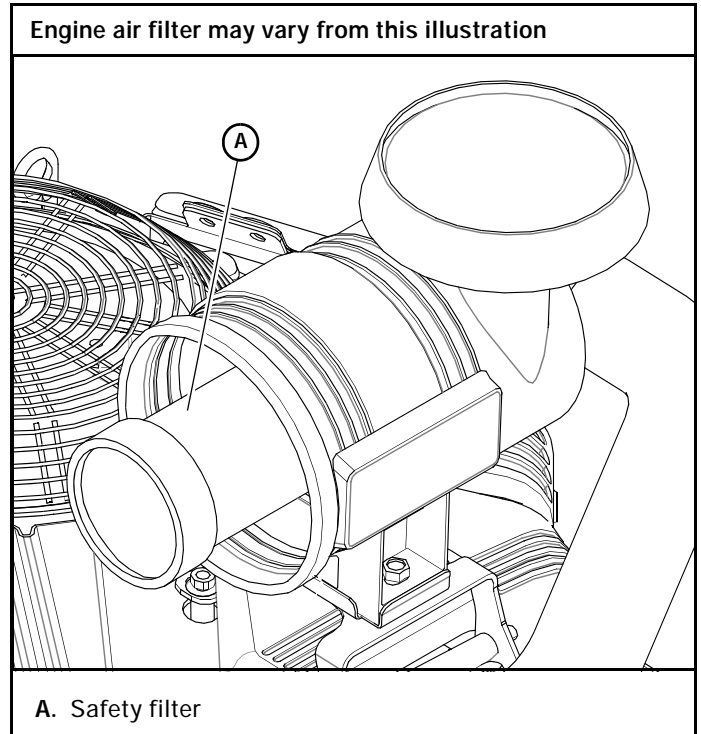

Figure 5-8

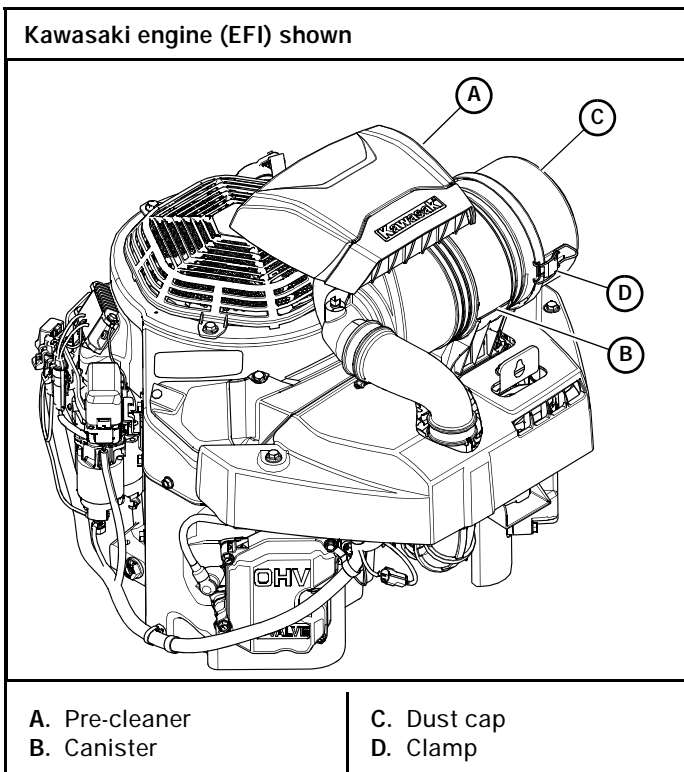

Figure 5-7

Recommended Service Procedure

1. Release clamps and remove element. Clean the air cleaner canister with a damp cloth.
2. Before installing a new element, inspect it by placing a bright light inside and rotating the element slowly, looking for any holes or tears in the paper. Also check gaskets for cuts or tears. Do not attempt to use a damaged element which will allow abrasive particles to enter the engine.
3. Reinstall the dust cap. Make sure it seals all the way around the air cleaner canister, then tighten the clamps. Figure 5-4, Figure 5-5 & Figure 5-6
4. Check all fittings and clamps periodically for tightness and inspect hoses for holes or cracks.
5. Periodically check the intake hose for signs of ingested dust. Locate and repair the source of ingested dirt.
6. Never operate the machine without an air filter installed.

Overservicing

Overservicing occurs when an air filter element is removed for cleaning or replacement before it is necessary. Each time the filter is removed a small amount of dirt and dust could fall in the intake system. This accumulated dirt can cause a dusted engine. It only takes a few grams of ingested dirt over the normal service life of an engine to cause a dusted engine.

Do not clean the element, but replace with a new element only. Cleaning used air filter elements, through improper cleaning procedures, can get dust on the inside of the filter causing dirt ingestion and engine failure.

It is important to note that whenever an air filter element is cleaned by **any method**, the person or company performing the cleaning assumes responsibility for the integrity of the filter from then on. **The warranty for air filters expires upon cleaning or servicing in any manner because the condition of the filter after servicing is completely out of the filter manufacturer's control. Therefore, on a dust ingested engine failure, there will be no warranty consideration if the air filter element has been cleaned or serviced in any manner.**

A partially dirty air filter element works better than a new element. Therefore, a dirty filter element is not bad for the engine unless it is excessively restricting the air flow and engine performance is affected. The media in the filter must be porous to allow air to pass through it. When dirty air passes through the filter, the dirt plugs some of the holes in the media and actually acts as part of the filter media. When the next round of dirt enters, the first dirt helps filter out even smaller particles making the filter more efficient at stopping dirt from entering the engine. This is referred to as barrier filtration.

At some point the filter media becomes too clogged to allow air to pass.

The mowing conditions will determine the frequency of air filter element changing.

Air Restriction Indicator

These units have an air restriction indicator installed in the air cleaner. Figure 5-9

Replace the element whenever the restriction indicator reaches the change filter red line. Check the indicator daily and replace element as needed or annually whichever occurs first.

Reset the indicator by pushing in on the yellow button after each element change. Figure 5-9



A. Reset button

B. Indicator

Figure 5-9

Fuel Evaporation System Filter

Some Hustler® Super 104™ mowers have a fuel evaporation system filter. This filter must be checked and replaced every 500 hours or annually whichever comes first. Figure 5-10

Fuel & Evaporative System Line Routings

There are two rubber hoses that are connected to the fuel tanks. One is the fuel hose that is part of the fuel system. The other is the vapor line that is part of the fuel evaporative system.

The fuel hose is connected to the fuel tank as shown. It connects the fuel tank to the fuel shutoff valve. Figure 5-11

The vapor line is connected to the fuel tank as shown. It connects the fuel tank to the engine's vapor port. Figure 5-12

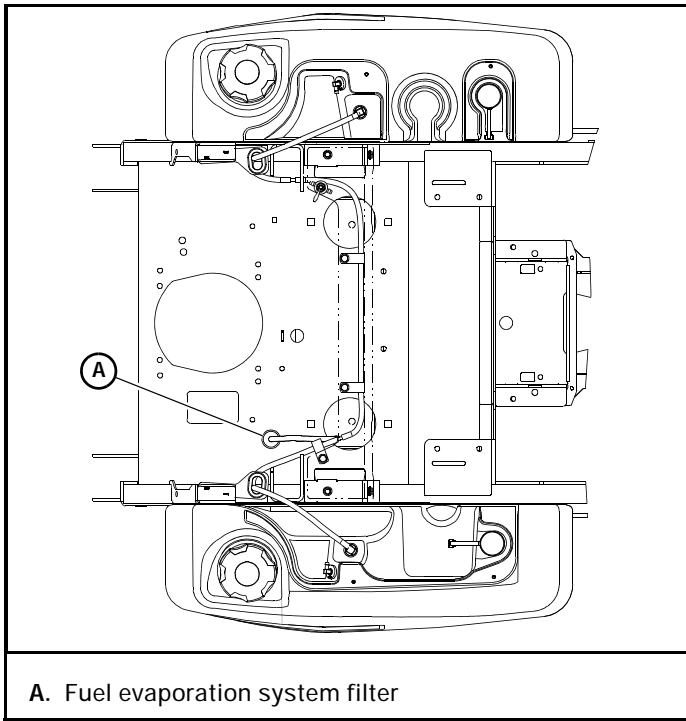

A. Fuel evaporation system filter

Figure 5-10

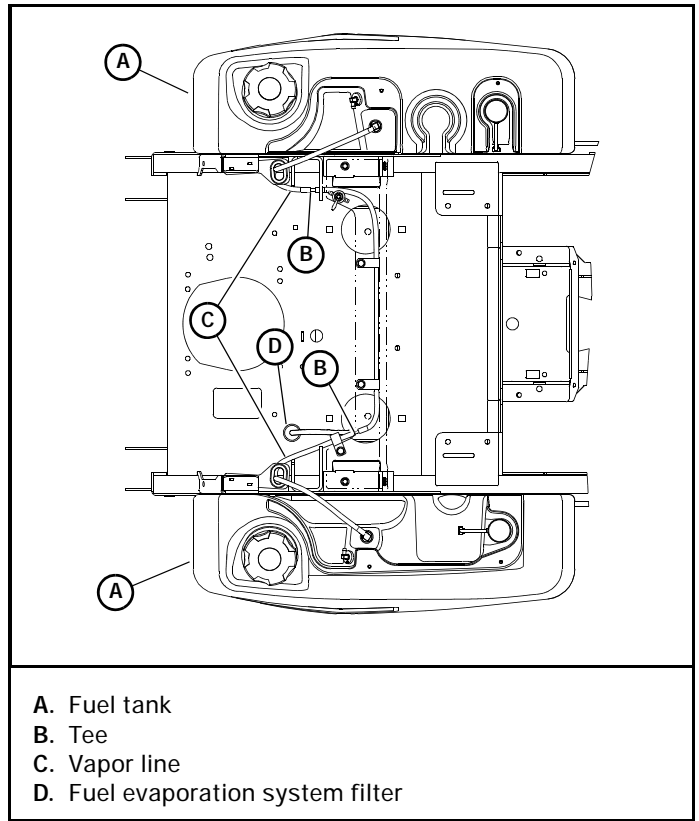

A. Fuel tank
 B. Tee
 C. Vapor line
 D. Fuel evaporation system filter

Figure 5-12

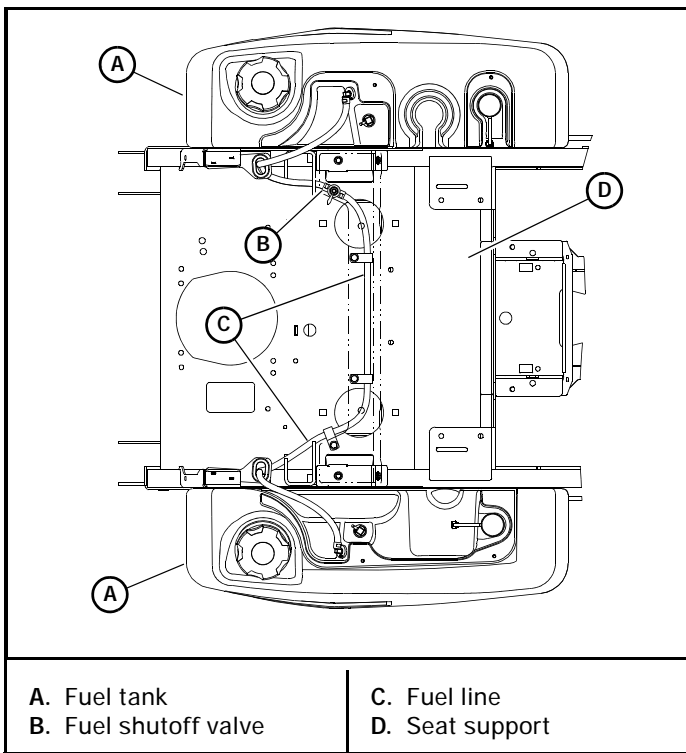

A. Fuel tank	C. Fuel line
B. Fuel shutoff valve	D. Seat support

Figure 5-11

Engine RPM Settings

The engine rpm's are set at the factory for maximum mowing efficiency. Occasionally it may be necessary to check and adjust the settings. The high idle speeds, with no load, should be set as follows:

Vanguard M61 / M61 EFI	
ENGINE SPEED	
Model No. ending with:	High idle
Model NO. without extension	3600 rpm
Kawasaki FX1000	
ENGINE SPEED	
Model No. ending with:	High idle
Model NO. with EX extension	3600 rpm
Model NO. with CE extension	Refer to mower's serial number plate

NOTE: Model numbers may or may not end with an extension after the number. There are several different extensions that may be shown; i.e. EX or CE.

Example: 922222 (no extension)
922222 EX
922222 CE
922222 US

DECK ADJUSTMENTS

Deck Leveling

WARNING  The deck lift mechanism is under pressure. Use caution when performing deck adjustments or maintenance. Figure 6-1

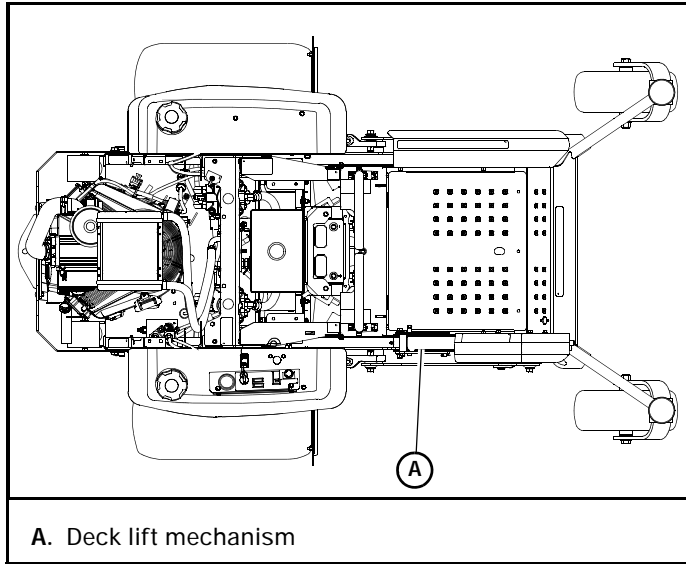
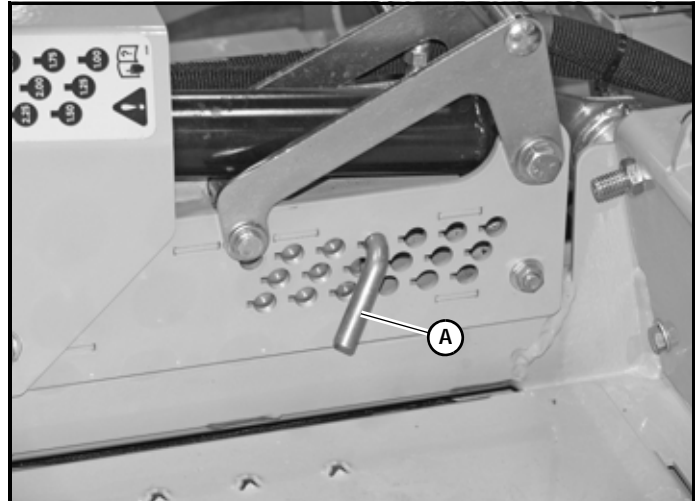

Figure 6-1

Center Deck Leveling

To level the center deck both side decks must be attached. Leveling the center deck must be done in the following manner:

1. Check tire pressures to make certain they are properly inflated before starting to level deck. The recommended pressures are as follows:
Drive wheels 15–20 psi (103–138 KPa)
Front wheels 20–25 psi (138–172 KPa)
2. Park the unit on a flat surface.
3. Raise the center deck and latch in the transport position.
4. Place the height stop pin in the 3.25" (82.6 mm) hole. Figure 6-2
5. Place 3" high deck support blocks (two stacked 2" x 4" blocks can be used to create a 3" [76.2 mm] high support) at the four corners of the center deck marked with the locator triangle as shown. Figure 6-3 & Figure 6-4
6. Lower the center deck onto the 3" (76.2 mm) blocks.



A. Height stop pin

Figure 6-2

7. Set the cutting height of the side decks at 3.25" (82.6 mm). Lower the side decks fully.

WARNING  Stop engine. Make sure deck clutch switch is in the down (OFF) position. Place control levers in the brake position before leaving machine.

8. Make sure the deck stop is firmly against the height stop pin. Figure 6-2

NOTE: The gas spring may keep block from contacting the height stop pin.

If this occurs, place a 1/2" drive break-over bar and extension into the square hole, in the deck lift linkage, and use it to move the deck and force the block against the height stop pin. Figure 6-5

9. Starting with the right front, adjust the nut on the deck lift hangers until the deck begins to take the weight off of the blocks. Then, repeat for the front left, rear right, and the left rear deck lift hangers. After all four hangers have been adjusted check to make sure that all four hangers are tight. Figure 6-6

Side Deck Leveling

IMPORTANT: The center deck must be level before the side decks can be leveled. Complete *Center Deck Leveling* section before continuing with the *Side Deck Leveling* procedure.

Leveling the side decks must be done in the following manner:

1. Check tire pressures to make certain they are properly inflated before starting to level deck. The recommended pressures are as follows:

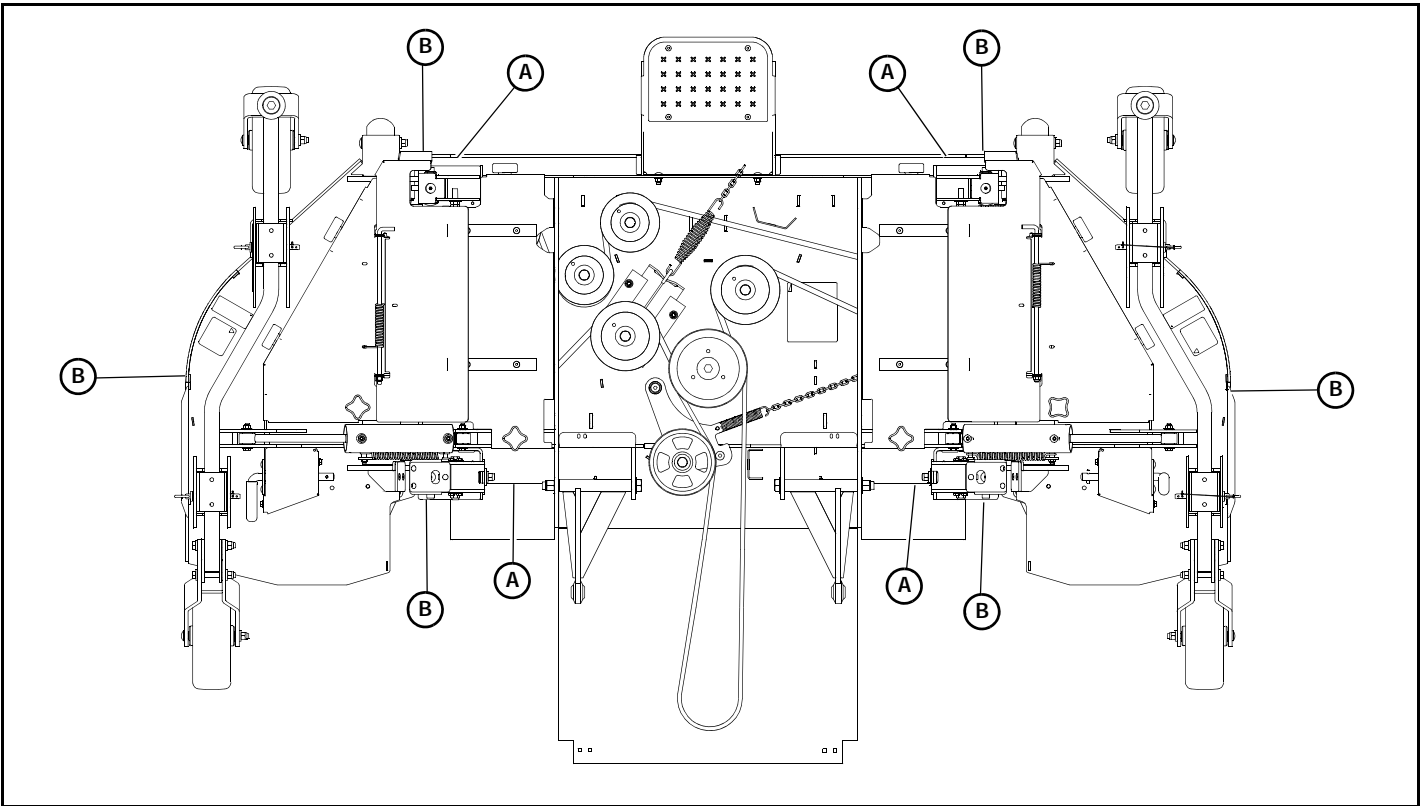

A. Measure to top of deck here
 B. 3" block

Figure 6-3

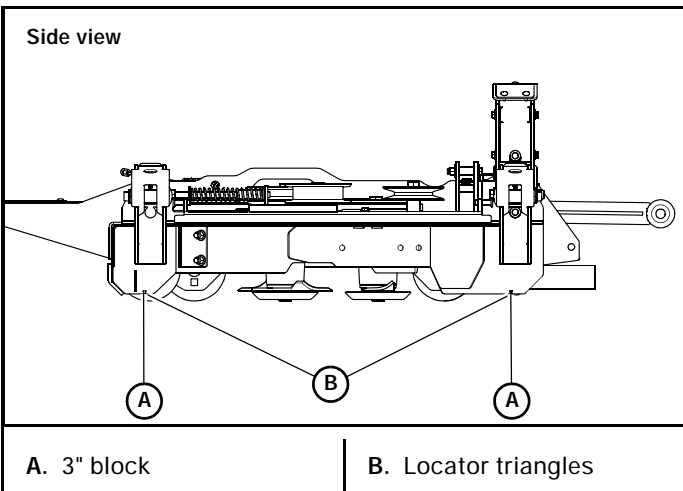

A. 3" block | B. Locator triangles

Figure 6-4

Drive wheels 15–20 psi (103–138 KPa)
 Front wheels 20–25 psi (138–172 KPa)

2. Park the unit on a flat surface.
3. Raise the center deck and latch in the transport position.
4. Place the height stop pin in the 3.25" (82.6 mm) hole.

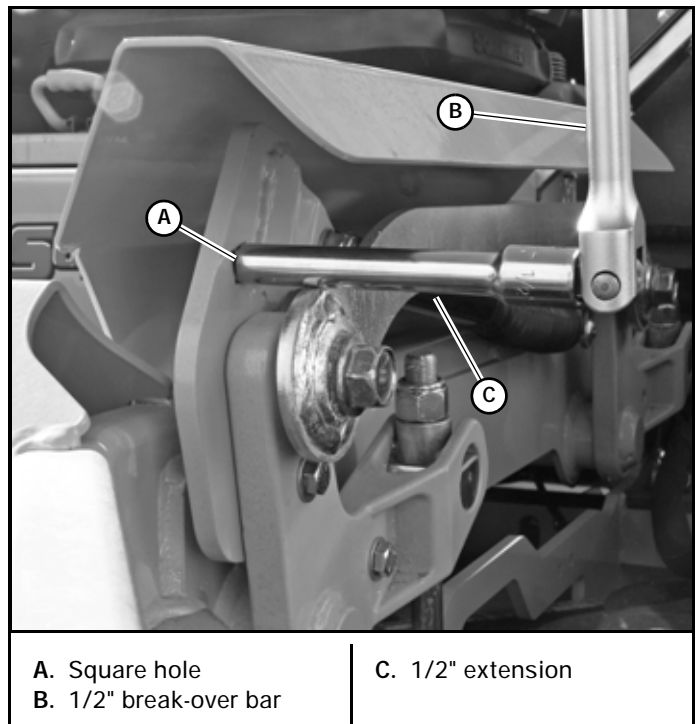

A. Square hole | B. 1/2" break-over bar | C. 1/2" extension

Figure 6-5

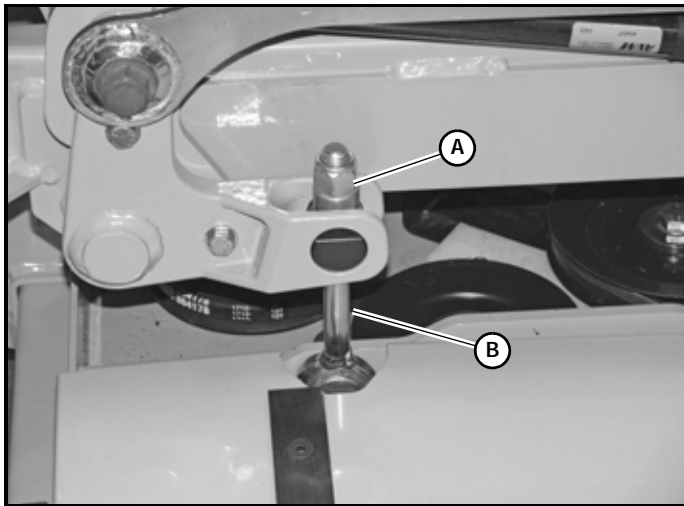

A. Nut B. Deck lift hanger

Figure 6-6

- Lower the center deck to rest against the stop pin.

WARNING

Stop engine. Make sure deck clutch switch is in the down (OFF) position. Place control levers in the brake position before leaving machine.

- Set the deck cutting height for the front and rear side deck gauge wheels at 3-1/4" (82.6 mm). Figure 6-7

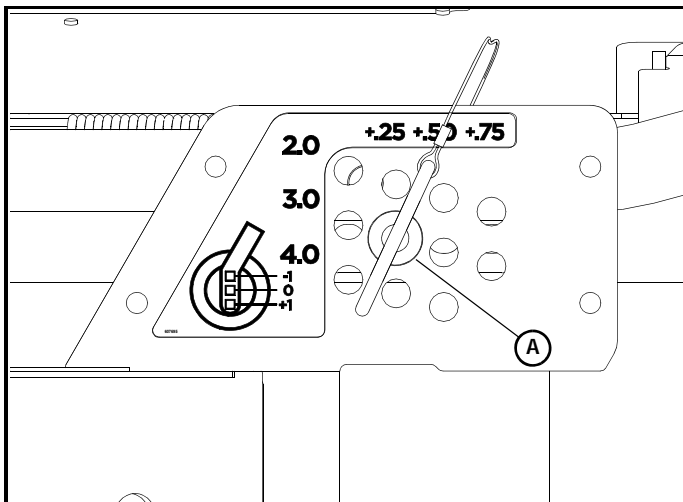

A. Set deck cutting height at 3-1/4"

Figure 6-7

- Place a 3" (76.2 mm) high deck support block (two stacked 2" x 4" blocks can be used to create a 3" [76.2 mm] high support) at the outside edge of the side deck. Figure 6-3 & Figure 6-8
- Lower the side decks to fully rest on the 3" (76.2 mm) blocks.

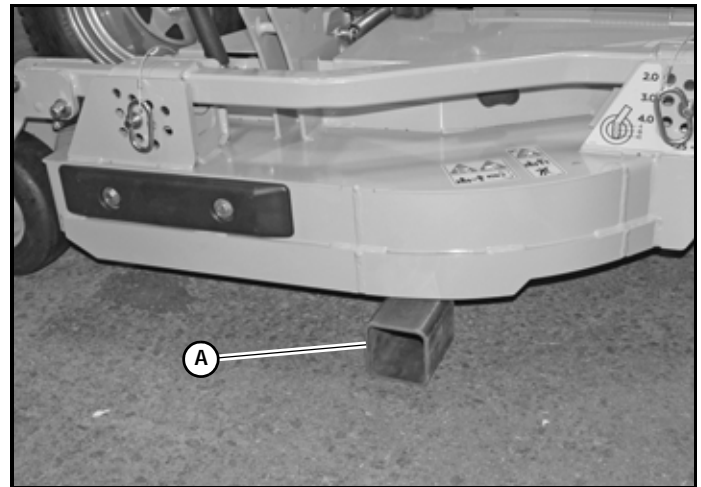

A. 3" (76.2 mm) block

Figure 6-8

- Loosen the two 1/2" bolts on the rear gauge wheel arm. Loosen the jam nut and adjusting bolt so the rear gauge wheel is not supporting any of the weight of the side deck. Figure 6-9

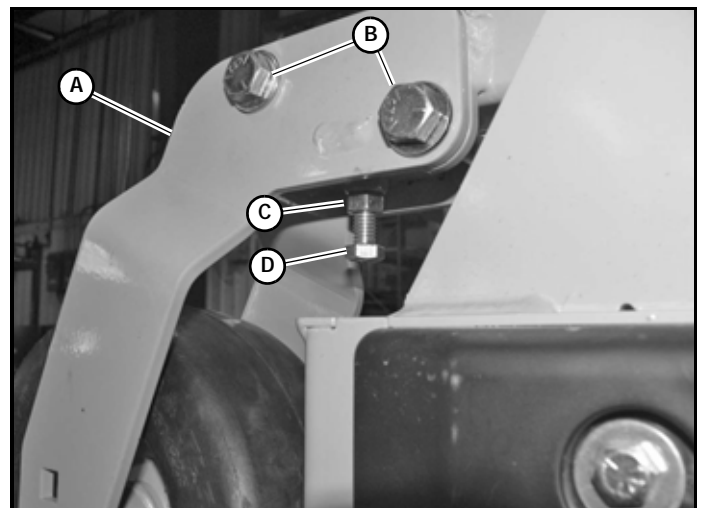

A. Rear wheel arm C. Jam nut
B. 1/2" bolts D. Adjusting bolt

Figure 6-9

- The front gauge wheel should contact the ground. If so, skip to Step 11. If not, the gauge wheel will need adjusted down per Step 12.
 - There should be less than .125" (3.18 mm) gap between the 3" deck block and the bottom side of the deck edge. Figure 6-8
- If so, go to Step 13. If not, the gauge wheel will need adjusted up per Step 12.
- Adjust the front gauge wheel up or down to satisfy your deck adjustment needs.

Adjustments are made by removing the front wheel from the wheel tube and re-arranging the two .125" (3.18 mm) and one .25" (6.35 mm) spacers located

above and below the front wheel pivot tube.
Figure 6-10

Once Steps 11 & 12 have been satisfied proceed to Step 13.

13. Adjust the rear gauge wheel height. Tighten the adjustment bolt on the bottom of the rear gauge wheel

fork assembly until the deck just begins to lift away from the 3" (76.2 mm) block. Figure 6-9

14. Tighten the jam nut. Figure 6-9

15. Tighten the two 1/2" rear wheel arm bolts. Figure 6-9

16. Repeat for the other side deck.

17. When done, lift the side decks and remove the 3" (76.2 mm) blocks.

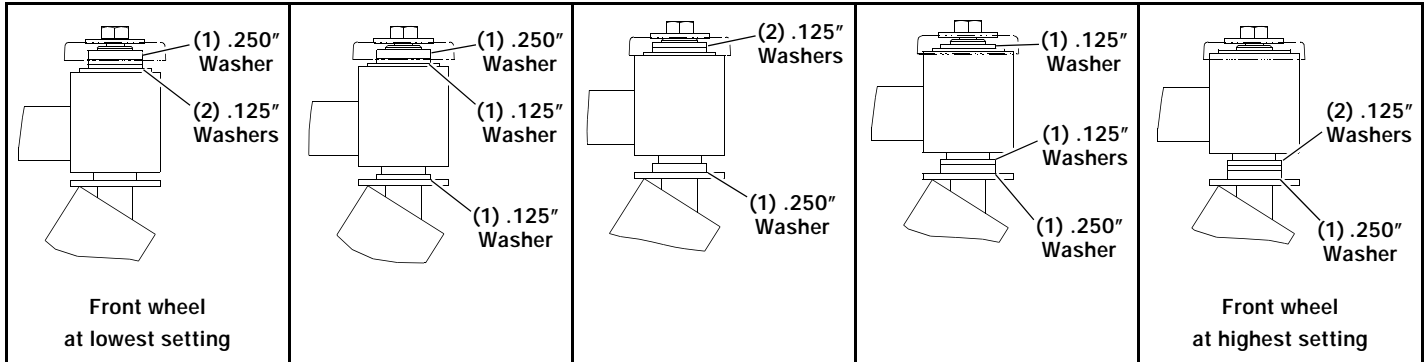

Figure 6-10

Blades

Mower Blade Maintenance

IMPORTANT: Refer to the *Safety* section of this manual for blade handling safety information.

Refer to the *Mower Blade Replacement* section for blade removal and installation.

WARNING Mower blades are sharp and can cut. Wrap the blade(s) or wear gloves and use extra caution when servicing them.

Check the mower blades daily, they are the key to power efficiency and well groomed turf. Keep the blades sharp. A dull blade will tear rather than cut the grass, leaving a brown ragged top on the grass within a few hours. A dull blade also requires more power from the engine.

Replace any blade which is bent, cracked or broken.

WARNING Always check for blade damage:

- if mower strikes a rock, branch or other foreign object during mowing!
- or if an abnormal vibration occurs while operating.

Make all necessary repairs before resuming operation.

Sharpen the blades following the pattern shown. Touch-up sharpening can be done with a file. Figure 6-11

After grinding the blades, check for balance. Blade balancing can be done by placing the blade on an inverted line punch or 5/8" bolt. A commercial balancing tool is also available through most hardware supply stores.

The blade should not lean or tilt. When spinning the blade slowly it should not wobble. Balance the blade before reinstalling.

Lay the blade on a flat surface and check for distortion. Replace any distorted blade. Figure 6-12 & Figure 6-13

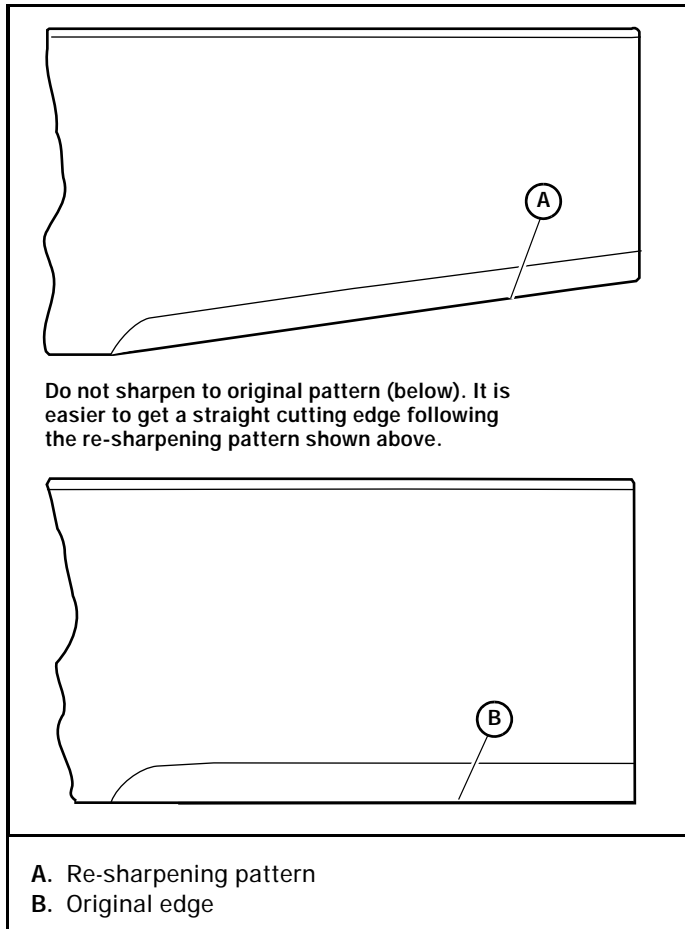

Figure 6-11

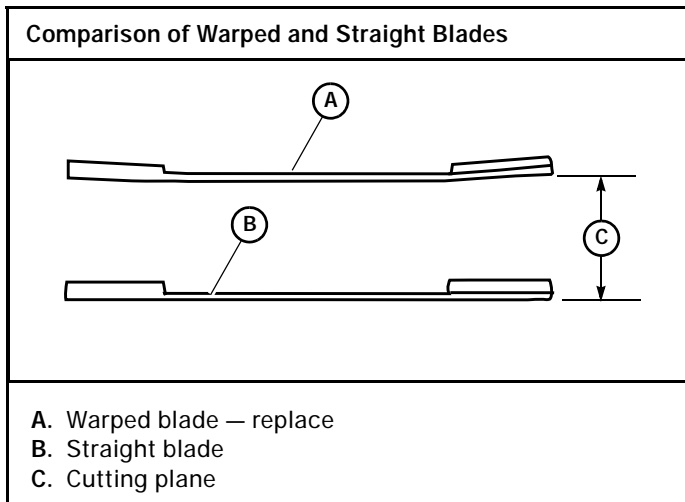

Figure 6-12

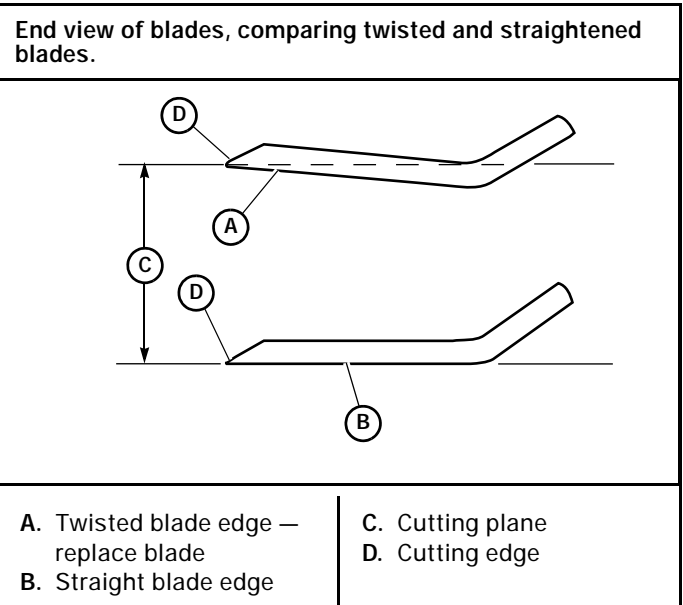

Figure 6-13

Mower Blade Replacement

IMPORTANT: Refer to the *Safety* section of this manual for blade handling safety information.



Mower blades are sharp and can cut. Wrap the blade(s) or wear gloves and use extra caution when servicing them.

A 15/16" wrench is required to remove the 5/8" cap screw holding the blade to the spindle shaft. **NOTE:** A blade holding tool (P/N 381442) is available from Hustler® Turf Equipment. It is designed to prevent the blades from rotating when they are being removed or installed on the spindle. Contact your Hustler® Dealer for more information.

Do not re-use spindle bolts which have stripped, worn or undercut threads. Torque bolts on spindles to 118 ft-lbs (160.0 N·m) when reinstalling blades.



Failure to correctly torque the bolt may result in the loss of the blade which can cause serious injury.

Properly compressed cup washers maintain the correct compression load on the blades. Replace the cup washers if they are cracked or flattened.

IMPORTANT: The blade sail (curved part) must be pointing upward toward the inside of the deck to ensure proper cutting.

When mounting blades, rotate them after installation to make sure blade tips do not touch each other or sides of the mower.

Belts

Inspect belts frequently for wear and serviceability. Replace a belt that shows signs of severe cuts, tears, separation, weather checking and cracking, or burns caused by slipping. Slight raveling of belt covering does not indicate failure; trim ravelings with a sharp knife.

Inspect the belt pulley grooves and flanges for wear. A new belt, or one in good condition, should never run against the bottom of the groove. Replace the pulley when this is the case, otherwise, the belt will lose power and slip excessively.

Never pry a belt to get it on a pulley as this will cut or damage the fibers of the belt covering.

Keep oil and grease away from belts, and never use belt dressings. Any of these will destroy the belt composition in a very short time.

Center Deck Belts Adjustment

The deck belt tension remains constant by means of a tension idler and spring. The spring tension should be such that the belt does not slip under normal operating load conditions, assuming the belt is not excessively worn or damaged. As the belt stretches and wears in, adjustment may become necessary. To increase belt tension, move the spring chain one (or more) link(s) at the anchor point on the deck frame. Figure 6-14, Figure 6-15 & Figure 6-16

IMPORTANT: Do not over tension the spring to compensate for a badly worn belt or pulley.

Side Deck Belt Adjustment

The side deck belt tension is adjusted by changing the compressed length of the idler spring.

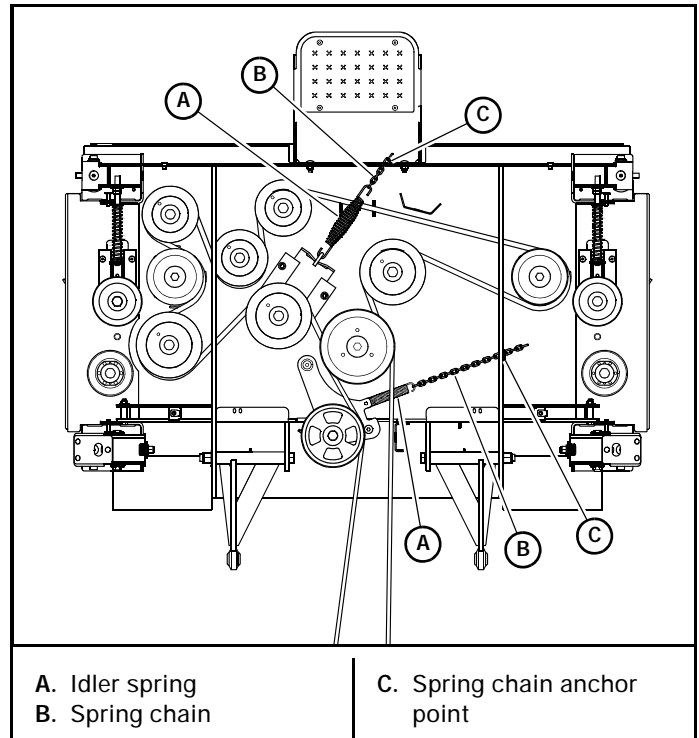

Figure 6-14

1. Loosen the jam nut. Figure 6-16
2. Rotate the adjustment nut the proper the direction until the idler spring is compressed to the dimension shown. Figure 6-16
3. Tighten the jam nut against the adjustment nut. Figure 6-16

Deck Troubleshooting

If you are experiencing issues with cut quality, deck discharge, or deck functionality refer to the *Troubleshooting* section of this manual.

Center Deck Belt Routing & Tensioning

NOTE:

1. Spring length after tensioning new belt. Measured from outside of hook to outside of hook with deck set at $\frac{3}{4}$ " (82.6 mm) cut height.
2. Route belts as shown.

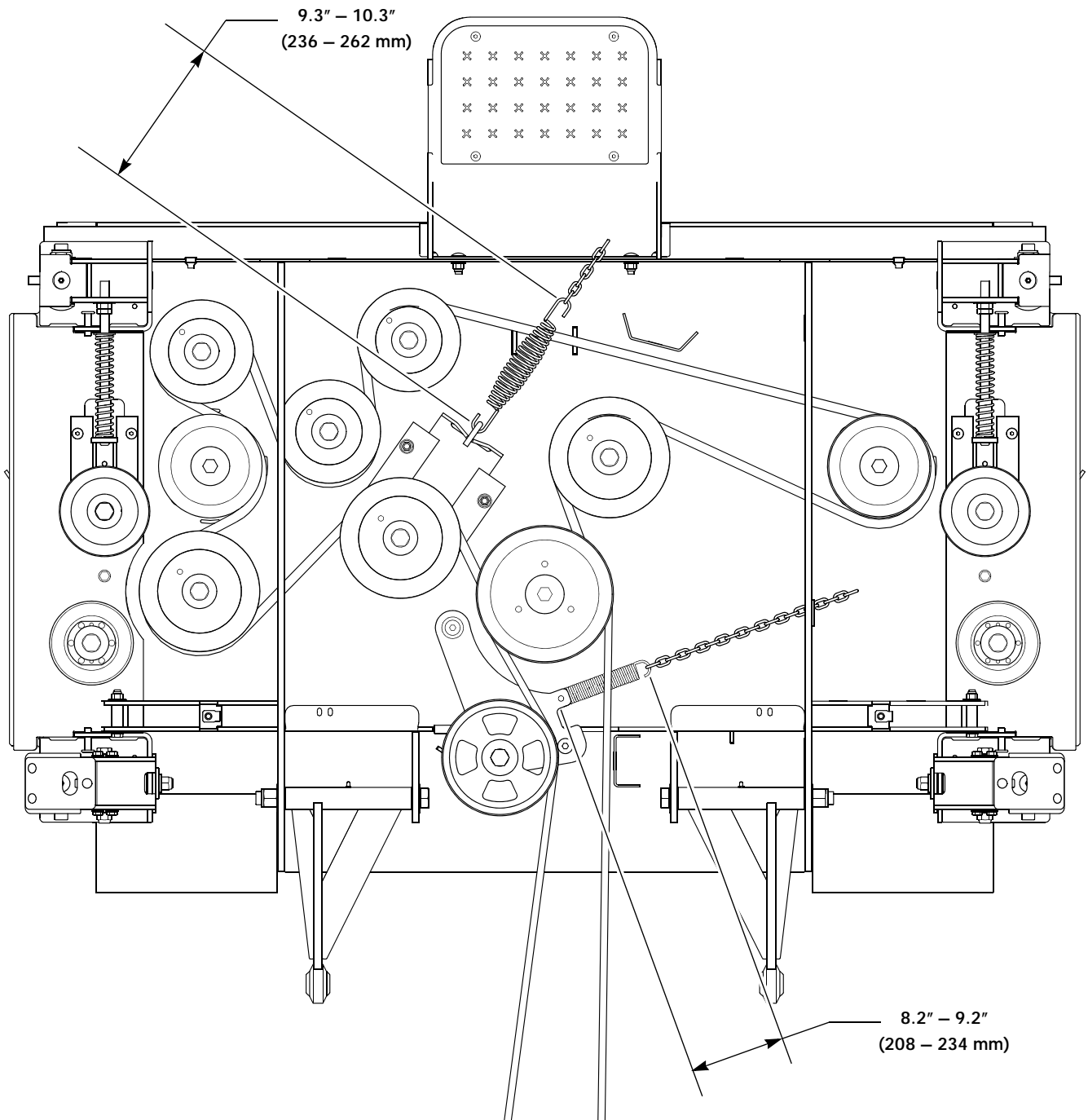

Figure 6-15

Center Deck To Side Deck Belt Routing & Tensioning

NOTE:

1. Spring length after tensioning new belt. Measured from one end of the spring to the other end with deck set at 3¼" (82.6 mm) cut height.
2. Route belts as shown.

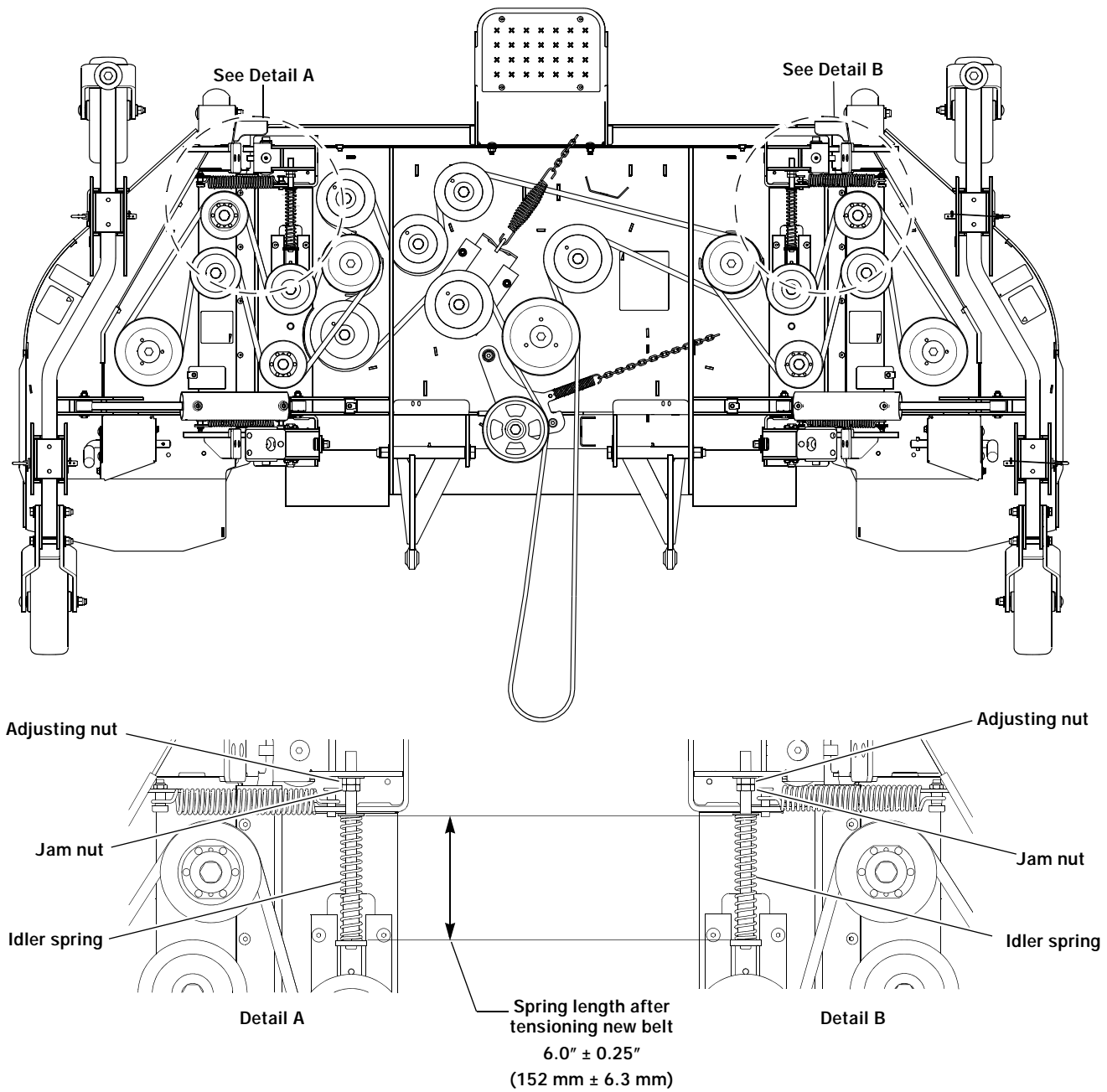
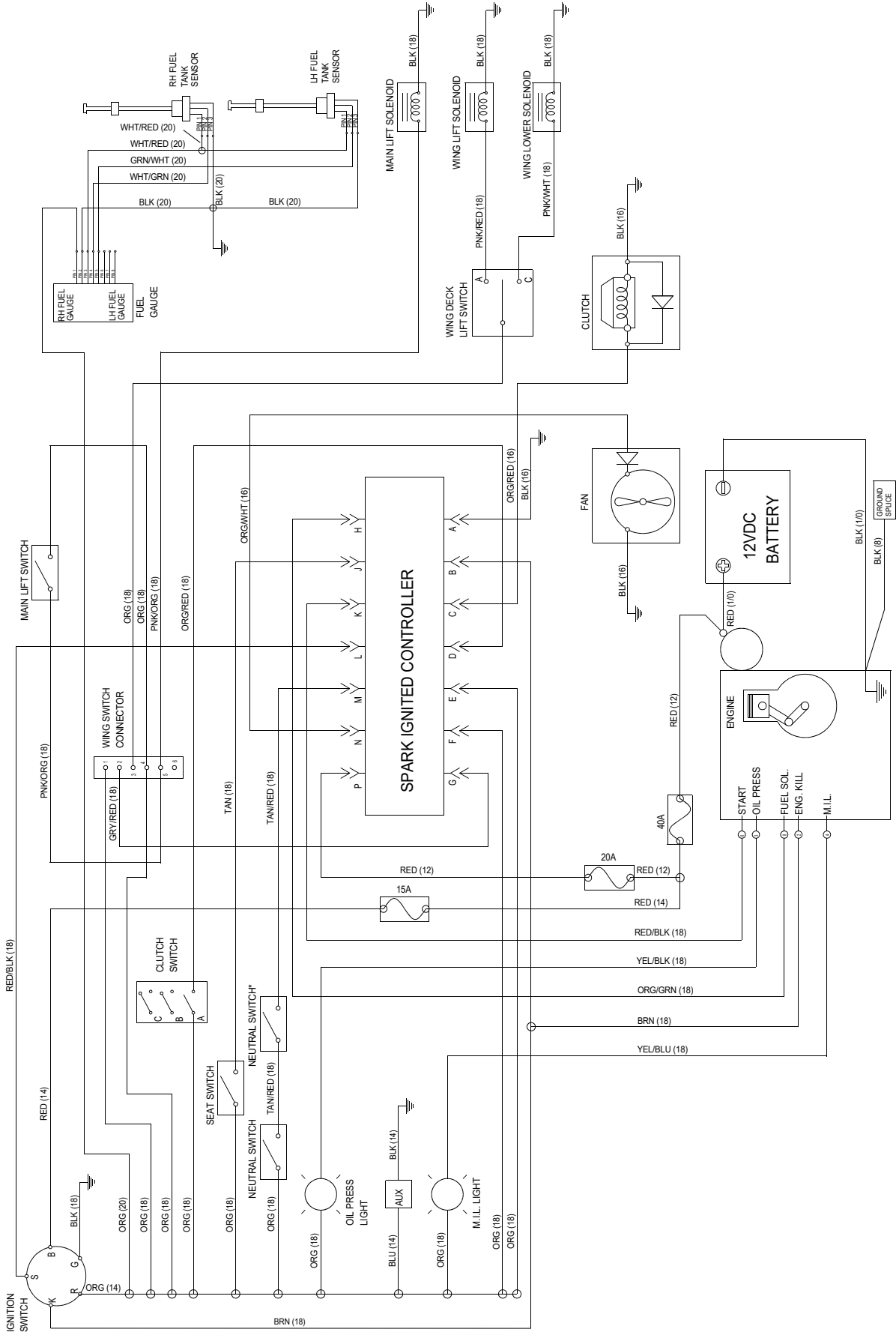

Figure 6-16

ELECTRICAL

Electrical Schematic – Vanguard Main Mower Harness



Electrical Schematic – Kawasaki Main Mower Harness

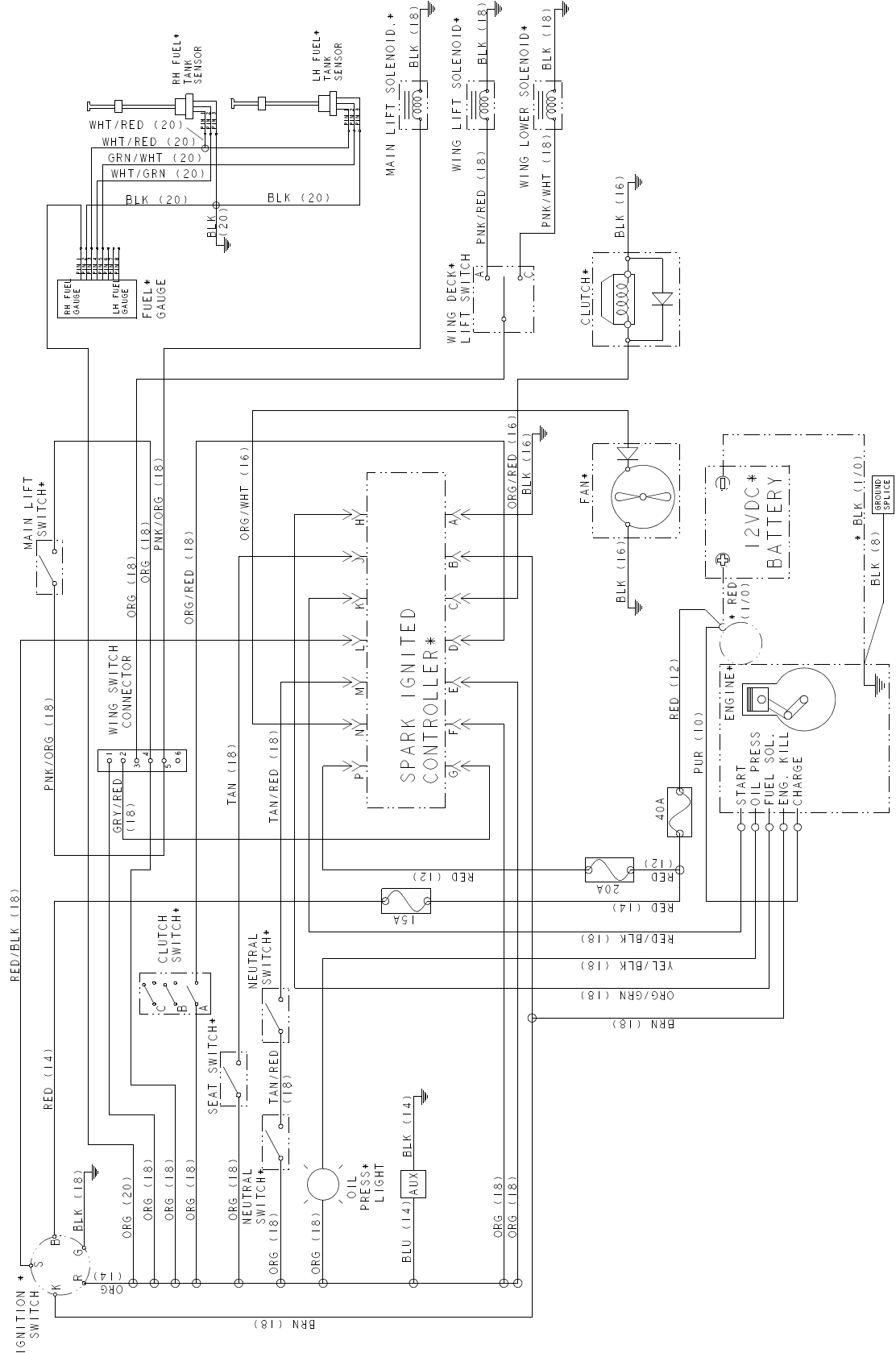

Electrical Schematic – Kawasaki (EFI) Main Mower Harness

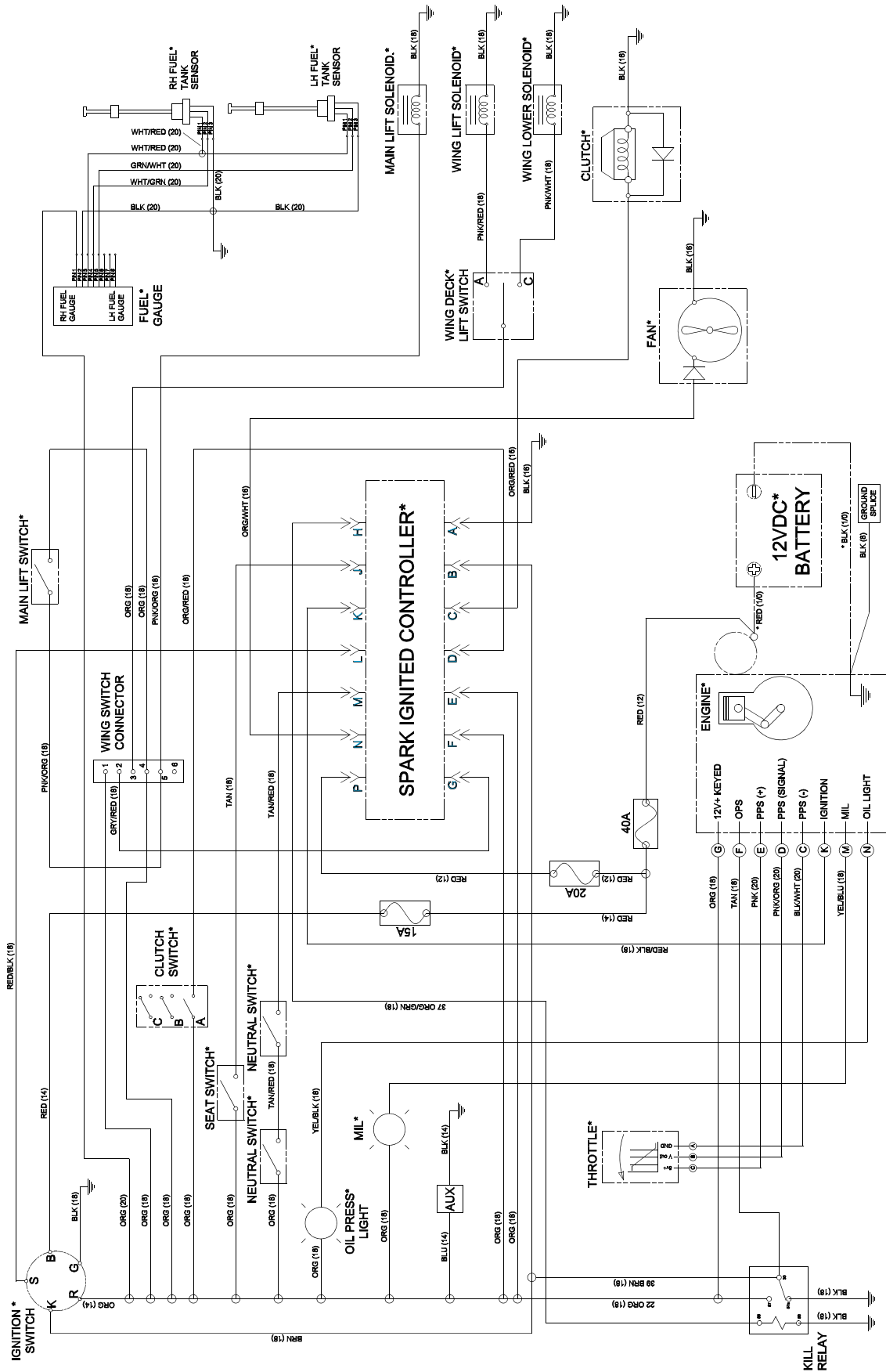

Electrical Schematic – Side Deck Harness

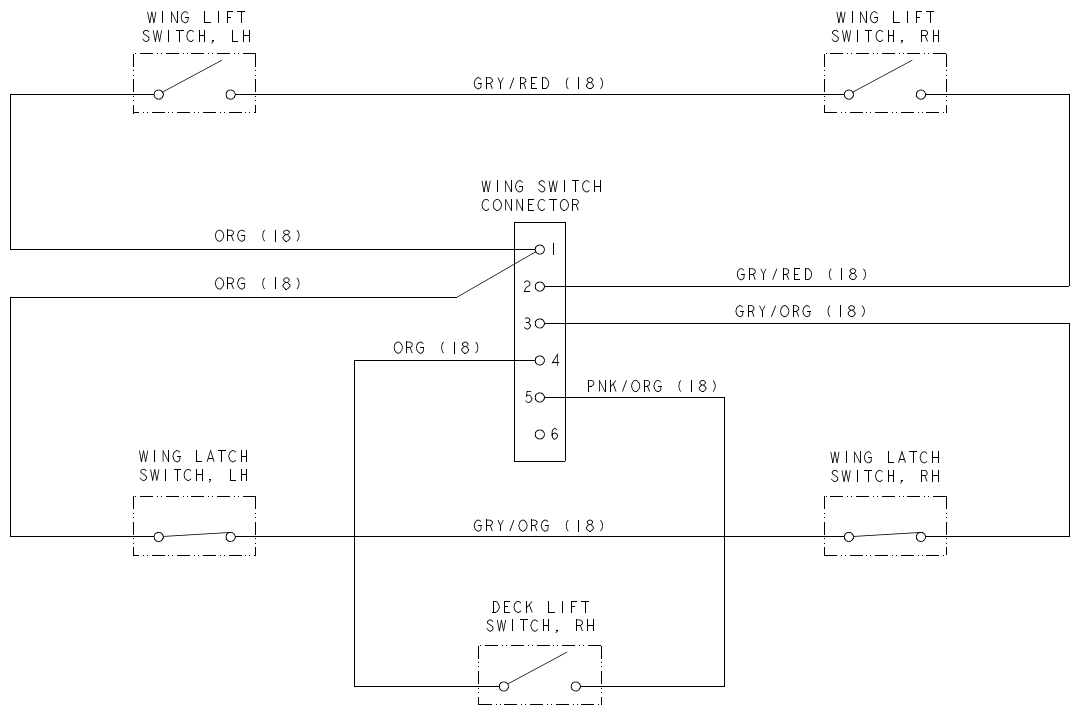

MAINTENANCE

Maintenance Schedule Figure 8-1, Figure 8-2, Figure 8-3, Figure 8-4, Figure 8-5, Figure 8-6, Figure 8-7, and Figure 8-8			
SERVICE AT INTERVALS INDICATED	WEEKLY OR 50 HOURS	MONTHLY OR 100 HOURS	* ANNUALLY OR 500 HOURS
Verify safety start interlock system	Prior to each use		
Visually inspect unit for loose hardware and/or damaged parts	Prior to each use		
Visually inspect tires	Prior to each use		
Check oil level, engine (1)	Prior to each use or every 4 hours		
Clean oil heat exchanger (8)	Prior to each use or every 4 hours		
Clean air intake screen (8)	Prior to each use or every 4 hours		
Check fuel level	Prior to each use		
Blades - sharpen and securely fastened	Prior to each use		
Rubber discharge guards - in good condition and securely in place	Prior to each use		
Caster fork tapered bearings (11)	Regular maintenance not required		
Clean engine and pump compartment	Daily		
Check air cleaner service indicator (8)	Daily		
Replace air cleaner element (5)	As needed		
Change engine oil and filter (1) (4)	X		
Clean cylinder and head fins (10)	X		
Check battery connections	X		
Check tire pressure with a gauge	X		
Check hydraulic oil level	X		
Clean engine exterior (10)	X		
Grease deck pusher arms (8)		X	
Grease side deck pivots		X	
Grease pump idler (8)		X	
Grease deck height pivots (8)		X	
Grease front wheel bearings (8)		X	
Grease gauge wheel bearings (8)		X	
Clean and re-gap spark plugs (10)		X	
Check pump and deck belt tension and condition (6)		X	
Check fuel system (7)		X	
Check hydraulic lines		X	
Check fuel valve (7)		X	
Check fuel tank grommet (7)		X	
Tighten lug nuts on wheels (2)		X	
Change fuel filter (7)			X
Clean or replace hydraulic fill cap			X
Change hydraulic filter and oil (3)			X
Grease deck spindle housings			X
Replace spark plugs			X
Check ROPS mounting hardware (9)			X
Replace fuel evaporation system filter (8)			X

NOTES:

1. Initial engine oil change is after 5 hours of operation. Thereafter, change oil after every 40 hours operation. Change more often under dusty or dirty conditions and during hot weather periods. Hustler® Motor Oil is recommended.
2. Torque initially and after first 2 hours of operation.
3. Perform initial hydraulic oil and filter change after 50 hours (one week) of operation. Thereafter, **change oil annually or every 500 hours** whichever comes first. Hustler® Full Synthetic 20W50 Hydrostatic Transmission Oil is recommended.
4. Change engine oil filter per the engine manufacturer's recommendations. Refer to Engine Owner's Manual for recommendations and other maintenance items.
5. Service more often under dusty or dirty conditions. Use caution when servicing to prevent dust contamination in the engine. **Do not** clean filter element. Replace with a new one.
6. **Pump drive belt only - Inspect every 100 hours** and replace if worn or cracking is noticed. Check spring tension adjustment. Otherwise, **replace belt every 400 hours or 2 years** whichever comes first. **Check and adjust the spring tension after 50 hours of use** as outlined in the *Hydraulic Pump Belt Adjustment* section of the Super 104™ General Service Manual (p/n 125816).
7. Check fuel system for any crack or leaks including, but not limit to, fuel line hoses, fuel valve, vent line hoses, vent valve, vapor valve, carbon canister, and grommets. Replace as needed.
8. More often under dusty or dirty conditions and during hot weather.
9. Inspect ROPS after the first 20 hours of operation and then after every 500 hours of operation or yearly whichever comes first.
10. Refer to engine owner's manual for engine service information.
11. If caster fork tapered bearing seals leak, refer to the Super 104™ General Service Manual (p/n 125816) for repair procedures.
12. Refer to the General Service Manual (P/N 125816) to service or repair the tapered wheel bearings.

* After completing maintenance cycle (500 hours), repeat cycle.

Maintenance Locator Chart

Mowers with Vanguard engines

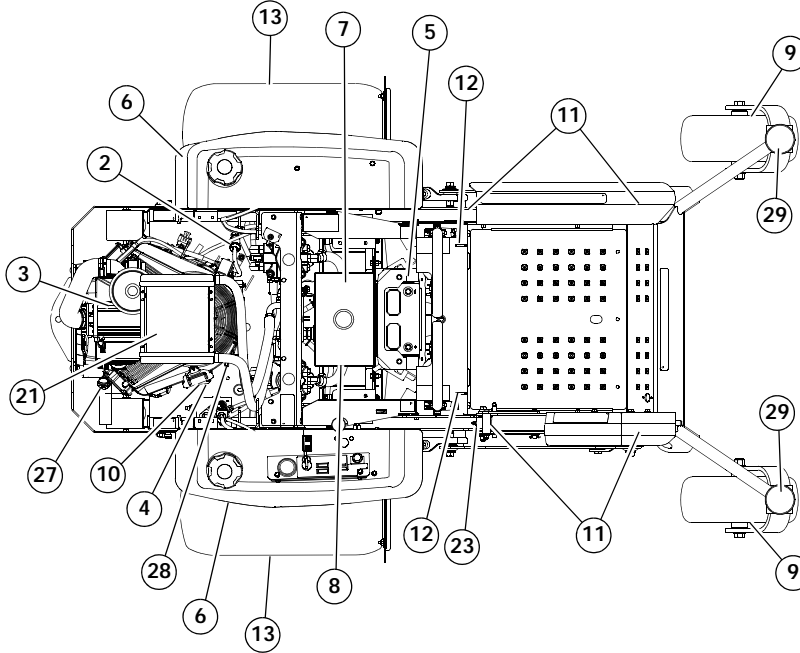

Figure 8-1

1. Engine Oil Fill and Dipstick (Kawasaki)
2. Fuel Filter
3. Engine Air Cleaner
4. Engine Oil Drain Plug
5. Battery
6. Fuel Tanks
7. Hydraulic Oil Reservoir
8. Hydraulic Oil Filter
9. Front Wheel Bearing Zerks (2)
10. Engine Oil Filter
11. Deck Height Pivot Zerks (4)
12. Park Brake Switch
13. Drive Tires

Mowers with Kawasaki engines

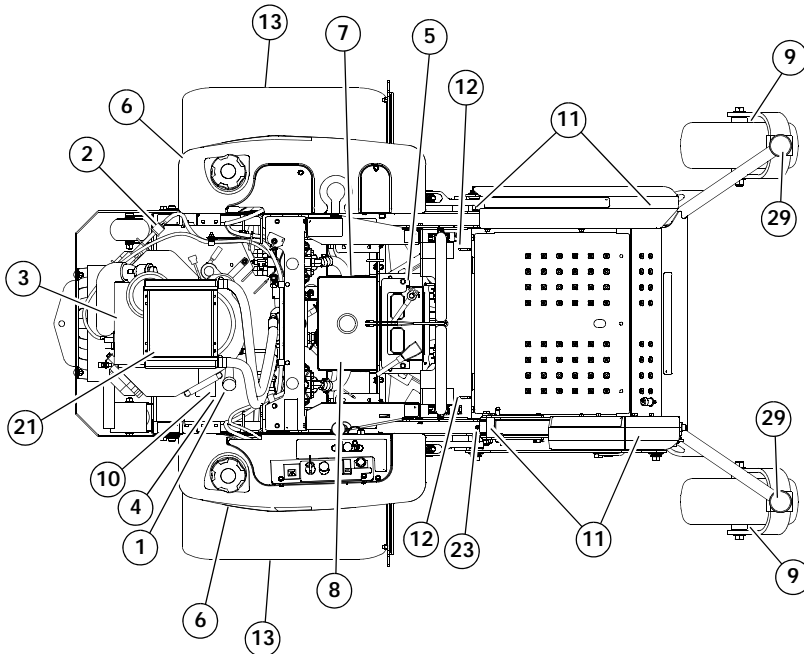

Figure 8-2

14. Pump Idler Zerk (1)
15. Pump Belt
16. Deck Pusher Arm Zerks (2)
17. Deck Belt - Deck Drive
18. Spindle Housing Zerk (5)
19. Blades
20. Fuel Evaporation System Filter
21. Hydraulic Oil Heat Exchanger
22. Deck Belt - Side Deck
23. Side Deck Pivot Zerks (4)
24. Deck Belt - Center Deck
25. Gauge Wheel Zerk (4)
26. Rubber Discharge Guards
27. Engine Oil Fill (Vanguard)
28. Engine Oil Dipstick (Vanguard)
29. Caster Fork Tapered Bearings

Mowers with Vanguard EFI engines

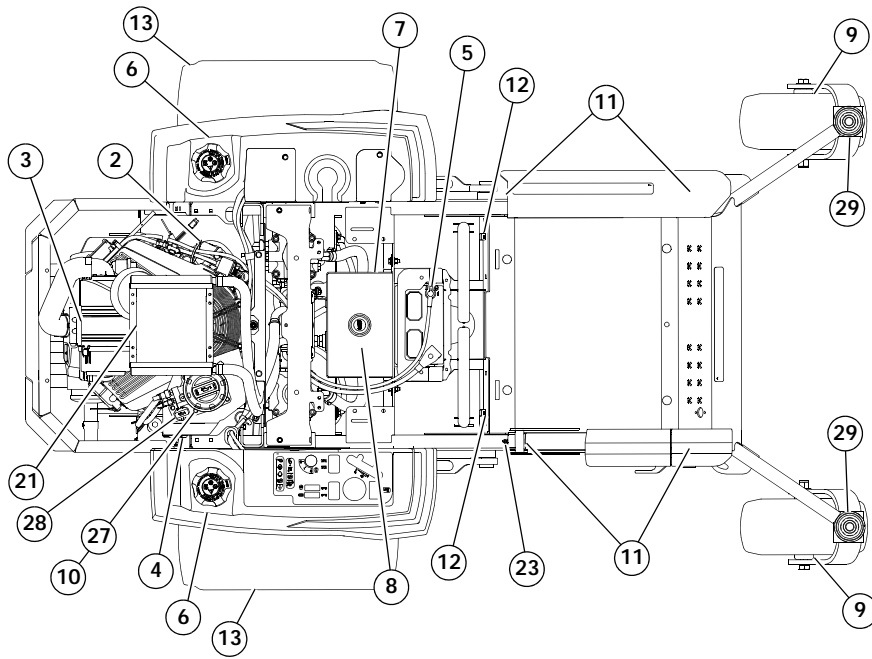

Figure 8-3

Mowers with Kawasaki EFI engines

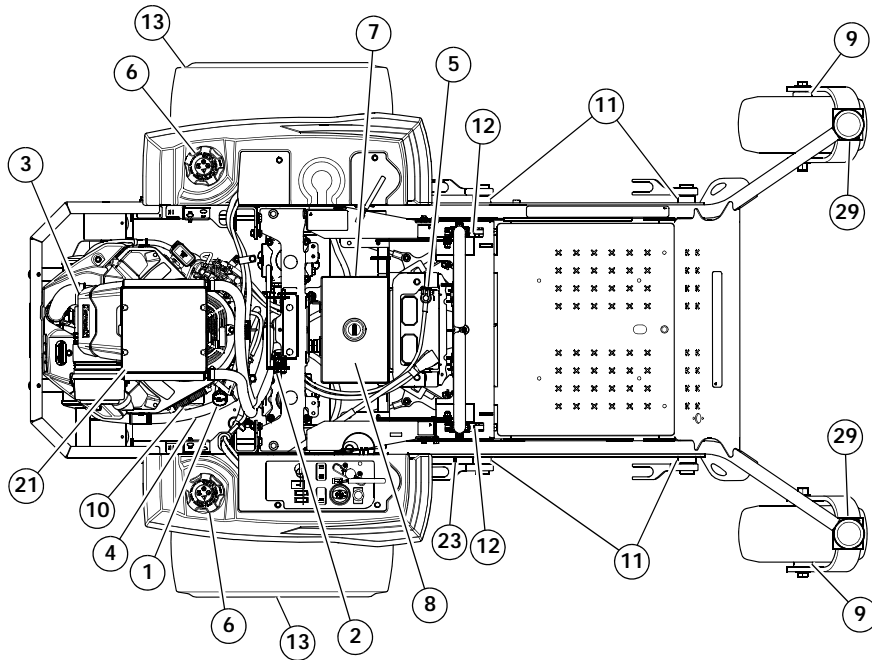

Figure 8-4

1. Engine Oil Fill and Dipstick (Kawasaki)
2. Fuel Filter
3. Engine Air Cleaner
4. Engine Oil Drain Plug
5. Battery
6. Fuel Tanks
7. Hydraulic Oil Reservoir
8. Hydraulic Oil Filter
9. Front Wheel Bearing Zerks (2)
10. Engine Oil Filter
11. Deck Height Pivot Zerks (4)
12. Park Brake Switch
13. Drive Tires
14. Pump Idler Zerk (1)
15. Pump Belt
16. Deck Pusher Arm Zerks (2)
17. Deck Belt - Deck Drive
18. Spindle Housing Zerk (5)
19. Blades
20. Fuel Evaporation System Filter
21. Hydraulic Oil Heat Exchanger
22. Deck Belt - Side Deck
23. Side Deck Pivot Zerks (4)
24. Deck Belt - Center Deck
25. Gauge Wheel Zerk (4)
26. Rubber Discharge Guards
27. Engine Oil Fill (Vanguard)
28. Engine Oil Dipstick (Vanguard)
29. Caster Fork Tapered Bearings

Figure 8-5

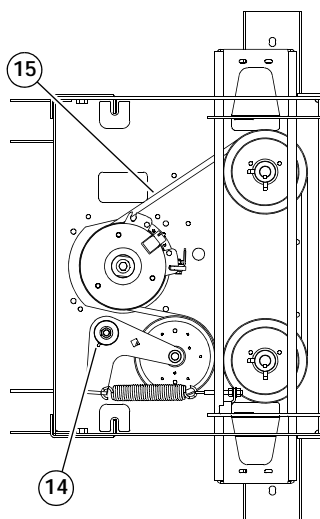
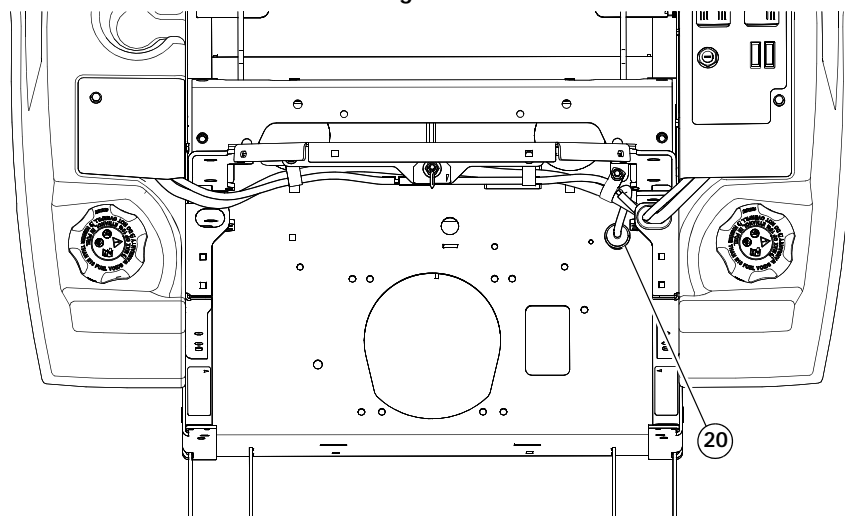

Figure 8-6



- 1. Engine Oil Fill and Dipstick (Kawasaki)
- 2. Fuel Filter
- 3. Engine Air Cleaner
- 4. Engine Oil Drain Plug
- 5. Battery
- 6. Fuel Tanks
- 7. Hydraulic Oil Reservoir
- 8. Hydraulic Oil Filter
- 9. Front Wheel Bearing Zerks (2)
- 10. Engine Oil Filter

- 11. Deck Height Pivot Zerks (4)
- 12. Park Brake Switch
- 13. Drive Tires
- 14. Pump Idler Zerk (1)
- 15. Pump Belt
- 16. Deck Pusher Arm Zerks (2)
- 17. Deck Belt - Deck Drive
- 18. Spindle Housing Zerk (5)
- 19. Blades
- 20. Fuel Evaporation System Filter

- 21. Hydraulic Oil Heat Exchanger
- 22. Deck Belt - Side Deck
- 23. Side Deck Pivot Zerks (4)
- 24. Deck Belt - Center Deck
- 25. Gauge Wheel Zerk (4)
- 26. Rubber Discharge Guards
- 27. Engine Oil Fill (Vanguard)
- 28. Engine Oil Dipstick (Vanguard)
- 29. Caster Fork Tapered Bearings

Figure 8-7

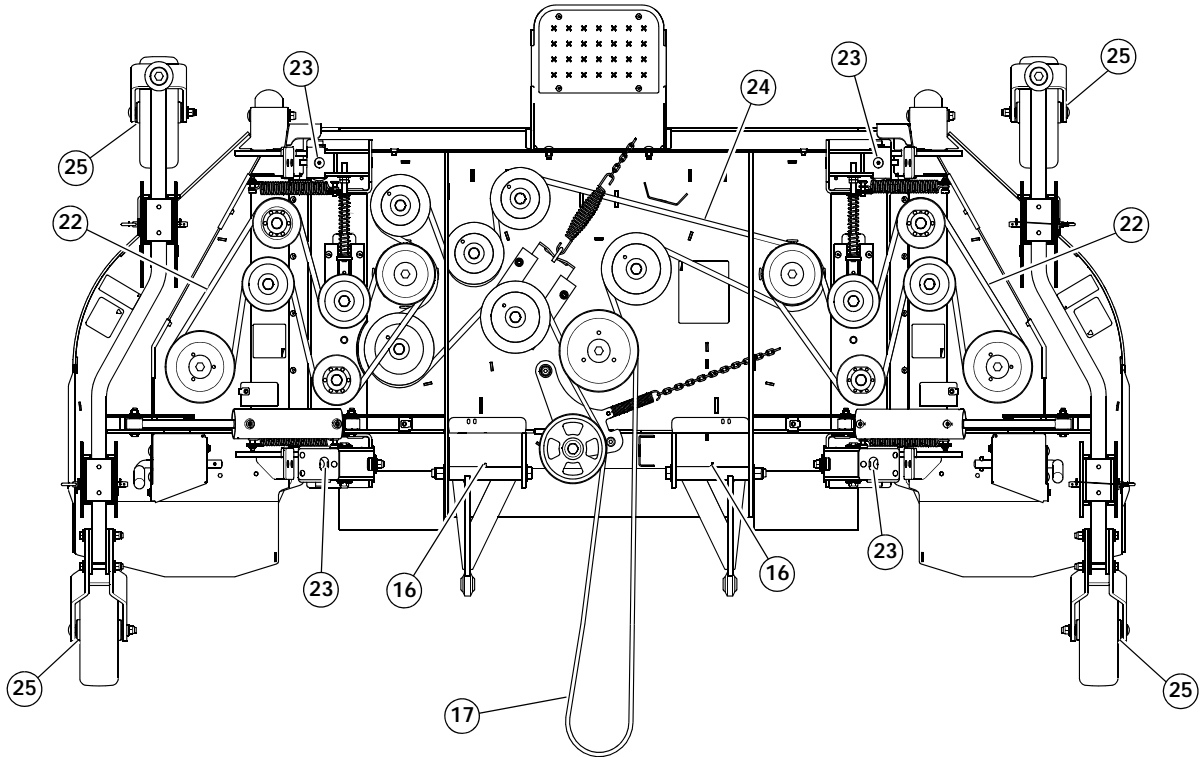

- | | | |
|--|------------------------------------|------------------------------------|
| 1. Engine Oil Fill and Dipstick (Kawasaki) | 11. Deck Height Pivot Zerks (4) | 21. Hydraulic Oil Heat Exchanger |
| 2. Fuel Filter | 12. Park Brake Switch | 22. Deck Belt - Side Deck |
| 3. Engine Air Cleaner | 13. Drive Tires | 23. Side Deck Pivot Zerks (4) |
| 4. Engine Oil Drain Plug | 14. Pump Idler Zerk (1) | 24. Deck Belt - Center Deck |
| 5. Battery | 15. Pump Belt | 25. Gauge Wheel Zerk (4) |
| 6. Fuel Tanks | 16. Deck Pusher Arm Zerks (2) | 26. Rubber Discharge Guards |
| 7. Hydraulic Oil Reservoir | 17. Deck Belt - Deck Drive | 27. Engine Oil Fill (Vanguard) |
| 8. Hydraulic Oil Filter | 18. Spindle Housing Zerk (5) | 28. Engine Oil Dipstick (Vanguard) |
| 9. Front Wheel Bearing Zerks (2) | 19. Blades | 29. Caster Fork Tapered Bearings |
| 10. Engine Oil Filter | 20. Fuel Evaporation System Filter | |

Figure 8-8

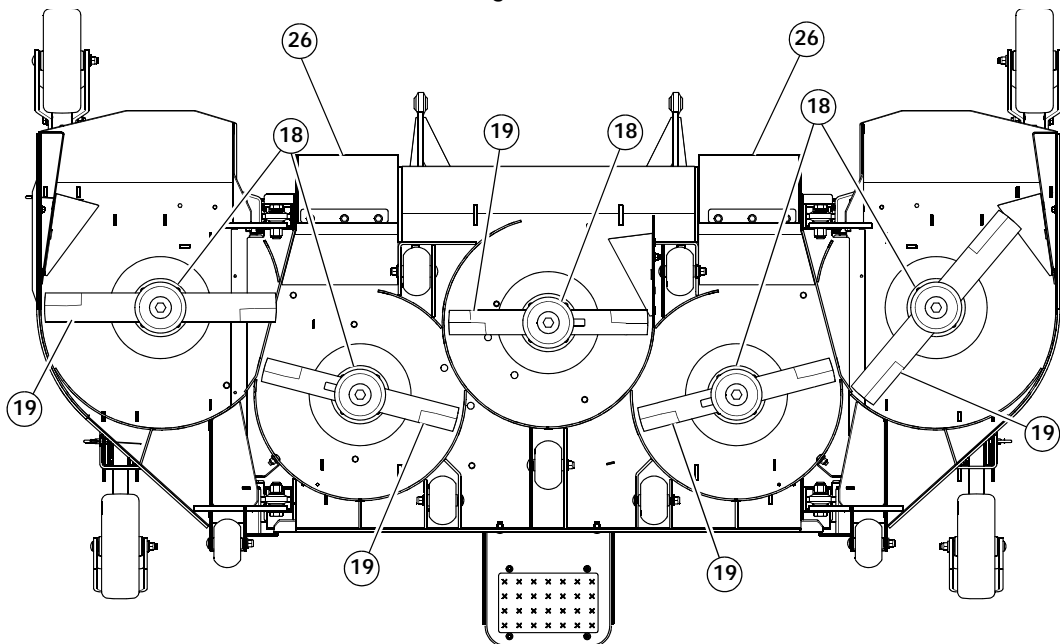

TROUBLESHOOTING

SYMPTOMS	PROBABLE CAUSES	SUGGESTED REMEDIES
Starting motor does not crank	Steering control levers not in park brake position or switch not adjusted	Place steering control levers in park brake position or re-adjust switch
	Deck clutch switch engaged	Disengage clutch switch
	Weak or dead battery	Recharge or replace
	Electrical connections are corroded or loose	Check the electrical connections
	For additional causes	See engine manual
The engine will not start, starts hard or fails to keep running	No fuel or line plugged	Fill tank or replace line (See <i>Fuel System</i> section for more details)
	Fuel valve is turned off	Open the fuel valve
	There is incorrect fuel in the fuel system	Drain the tank and replace the fuel with the proper type
	There is dirt in the fuel filter	Replace the fuel filter
	Dirt, water or stale fuel in the fuel system	Contact your dealer
	The choke is not on (if equipped)	Move the choke lever to ON
	Numerous	See engine manual
Engine: Runs with continuous misfiring or engine runs unevenly or erratically	Numerous	See engine manual
Loss of power or system will not operate in either direction	Restrictions in air cleaner	Service air cleaner
	Hydraulic line blockage	See your dealer
	Internal interference or leakage in wheel motor	See your dealer
	Insufficient hydraulic oil supply	Check level in reservoir
		Have dealer check hydraulic pump
	Poor compression	See your dealer
	Steering linkage needs adjustment	Adjust linkage
	Tow valve open	Close tow valve
	The traction drive belt is worn, loose or broken	Install a new traction drive belt
	Air in system	Check filter and fittings
For additional causes	See engine manual	
Low engine oil pressure	Low oil level	Add oil
	Oil diluted or too light	Change oil and check for source of contamination
	Failed oil pump	Contact your dealer
High oil consumption	Numerous	Contact your dealer
Mower jerky when starting or operates in one direction only	Steering control linkage needs adjustment	Adjust linkage
	Pump or wheel motors faulty	Contact your dealer
	Tow valves not closed completely	Close tow valves

SYMPTOMS	PROBABLE CAUSES	SUGGESTED REMEDIES
Hydraulic system operates hot (oil in reservoir smells rancid)	Low hydraulic oil level	Fill reservoir
	Hydraulic pump faulty	Contact your dealer
	Hydraulic oil heat exchanger clogged	Clean oil heat exchanger core
Mower creeps when steering control levers are in neutral	Steering linkage needs adjustment	Adjust linkage
Mower circles or veers in one direction	Steering linkage needs adjustment	Adjust linkage
	Wheel motors faulty	Contact your dealer
	Tires improperly inflated	Adjust air pressure to drive tires 15–20 psi (103–138 KPa). Front tires 20–25 psi (138–172 KPa)
Mower creeps when parking brake engaged	Steering linkage out of adjustment	Adjust steering linkage
	Brakes need adjustment	Adjust parking brakes
There is abnormal vibration	The engine mounting bolts are loose	Tighten the engine mounting bolts
	The engine pulley, idler pulley or blade pulley is loose	Tighten the appropriate pulley
	The engine pulley is damaged	Contact your dealer
	The cutting blade(s) is/are bent or unbalanced	Install new cutting blade(s)
	A blade mounting bolt is loose	Tighten the blade mounting bolt
	Spindle bearing is worn or loose	Replace or tighten spindle bearing
Blades do not rotate	A blade spindle is bent	Contact your dealer
	The deck drive belt is worn, loose or broken	Install a new deck drive belt
	The deck drive belt is off the pulley	Install the deck drive belt and check for a reason
	Electric clutch is not engaging	Check and/or replace 10 amp fuse. Contact your dealer

SYMPTOMS	PROBABLE CAUSES	SUGGESTED REMEDIES
Uneven cutting height	The blade(s) are not sharp	Sharpen the blades
	A cutting blade(s) is/are bent	Install new cutting blade(s)
	The deck is not level	Level the deck per the <i>Deck leveling and height adjustment</i> section of the General Service Manual
	An anti-scalp wheel is not set correctly	Adjust the height of the anti-scalp wheel
	The underside of the deck is dirty	Clean the underside of the deck
	Tires improperly inflated	Adjust air pressure to drive tires 15–20 psi (103–138 KPa). Front tires 20–25 psi (138–172 KPa)
	A blade spindle is bent	Contact your dealer
	Flex Forks [®] are installed	Level the deck per the <i>Deck leveling and height adjustment</i> section of the General Service Manual

Cut Quality and Discharge Management		
Symptoms	Probable causes	Suggested Remedies
Grass discharges in clumps	Grass is wet	Lower ground speed to allow deck to process grass better.
	Too much grass is being removed in one cutting.	Mow more frequently. Mow multiple times at successively lower cut heights.
Grass discharge is concentrated in ZONE 1 for CHAMBERS 1, 3, and 5. <i>(Refer to Deck Zone Chart for clarification)</i>	Spreader triangles are too far rearward.	Re-position spreader triangles in the next forward hole on affected cutting CHAMBERS.
Grass discharge is concentrated in ZONE 2 for CHAMBERS 1, 3, and 5. <i>(Refer to Deck Zone Chart for clarification)</i>	Spreader triangles are too far forward.	Re-position spreader triangles in the next rearward hole on affected cutting CHAMBERS.
Uneven cutting height	The deck is not level.	Level the deck per the "Deck Leveling and Height Adjustment" section of the General Service Manual.
	Tires are improperly inflated.	Adjust air pressure to drive tires 15–20 psi (103–138 KPa). Front tires 20–25 psi (138–172 KPa)
Deck(s) scalping grass on uneven ground	Anti-scalp wheels are set too high for cutting height and conditions.	Lower all anti-scalp wheels.
Grass is not being cut on side deck when mowing crown of hills or other undulations	Side deck hydraulic cylinders are not fully extended to allow ±15 degree articulation.	Fully extend the side deck hydraulic cylinders using the side deck lift switch.
Inconsistent cut quality across width of deck	Wrong blade length, rotation.	Match red blades to red spindles and black blades to black spindles for correct rotation. Refer to <i>Deck Zone Chart</i> and the <i>Blade Identification Chart</i> for correct blade placement.
	The blades are not sharp.	Sharpen the blades.
	Cutting blade(s) are damaged or bent.	Install new cutting blade(s).
	A blade spindle is bent.	Contact your Hustler® dealer.
	The underside of the deck is dirty.	Clean the underside of the deck.
Air or debris blowout on front of deck <i>(Refer to Deck Zone Chart for clarification)</i>	Cut height is set too high for conditions, causing too much air flow.	Reduce deck cut height.

Deck Functionality		
Symptoms	Probable causes	Suggested Remedies
Grass is not being cut by side deck when mowing crown of hills or other undulations.	Side deck hydraulic cylinders are not fully extended to allow ± 15 degree articulation.	Fully extend the side deck hydraulic cylinders using the side deck lift switch.
Deck shuts off while mowing.	Side deck angle switch is disengaged.	Move vehicle to flat ground and fully extend side deck cylinders. Push the deck clutch switch down to the disengaged "OFF" position. Then, pull the deck clutch switch up to engage the blade clutch and resume mowing.
Blade(s) do not rotate/clutch will not engage.	Side deck angle switch is disengaged.	Move vehicle to flat ground and fully extend side deck cylinders. Push the deck clutch switch down to the disengaged "OFF" position. Then, pull the deck clutch switch up to engage the blade clutch and resume mowing.
	Side deck transport switch is engaged.	Manually release side deck transport latches - both side decks must be unlatched. Fully extend side deck cylinders, lowering side decks to cutting position. Side decks must be fully lowered to engage PTO.
Center deck will not lower into cutting position.	Transport latch is engaged when center deck lift switched is pushed.	Push transport switch and raise deck lift to maximum height. Pull and hold transport latch back, release transport switch and allow deck to lower to desired cut height.
Side decks will not lower into cutting position.	Side deck transport switch is engaged.	Manually release side deck transport latches - both side decks must be unlatched. Fully extend side deck cylinders, lowering side decks to cutting position.

Deck Zone Chart

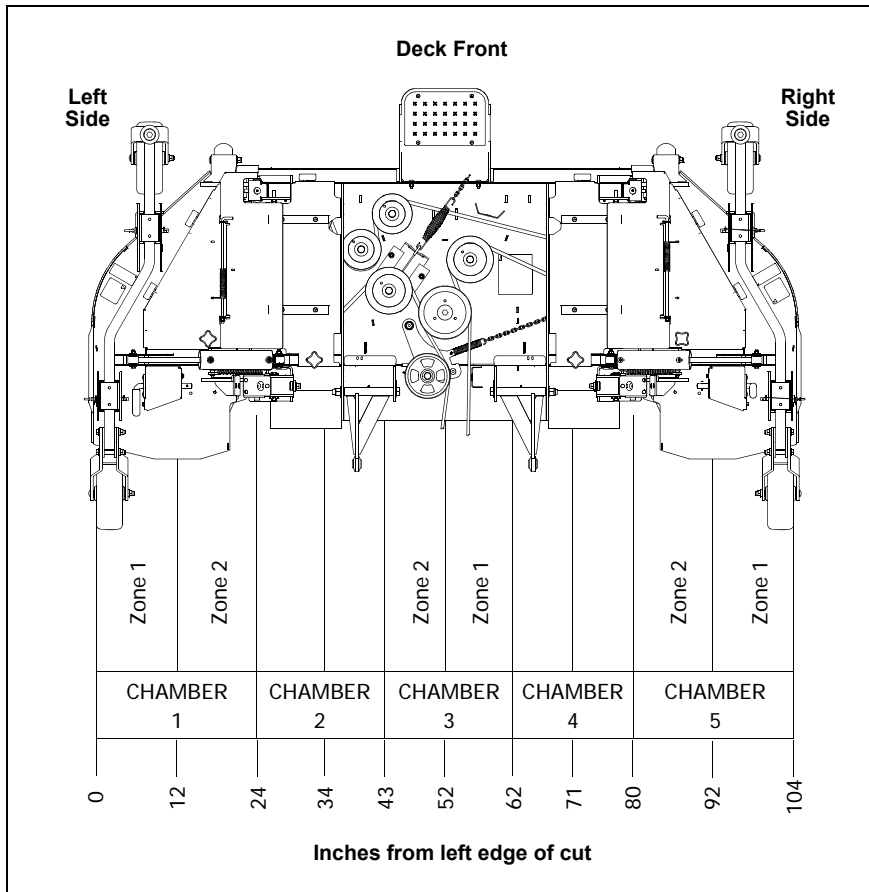

BLADE IDENTIFICATION TABLE

CHAMBER	BLADE COLOR	BLADE LENGTH (IN)
1	RED	23.86
2	RED	20.5
3	BLACK	20.5
4	BLACK	20.5
5	BLACK	23.86

DETAIL A

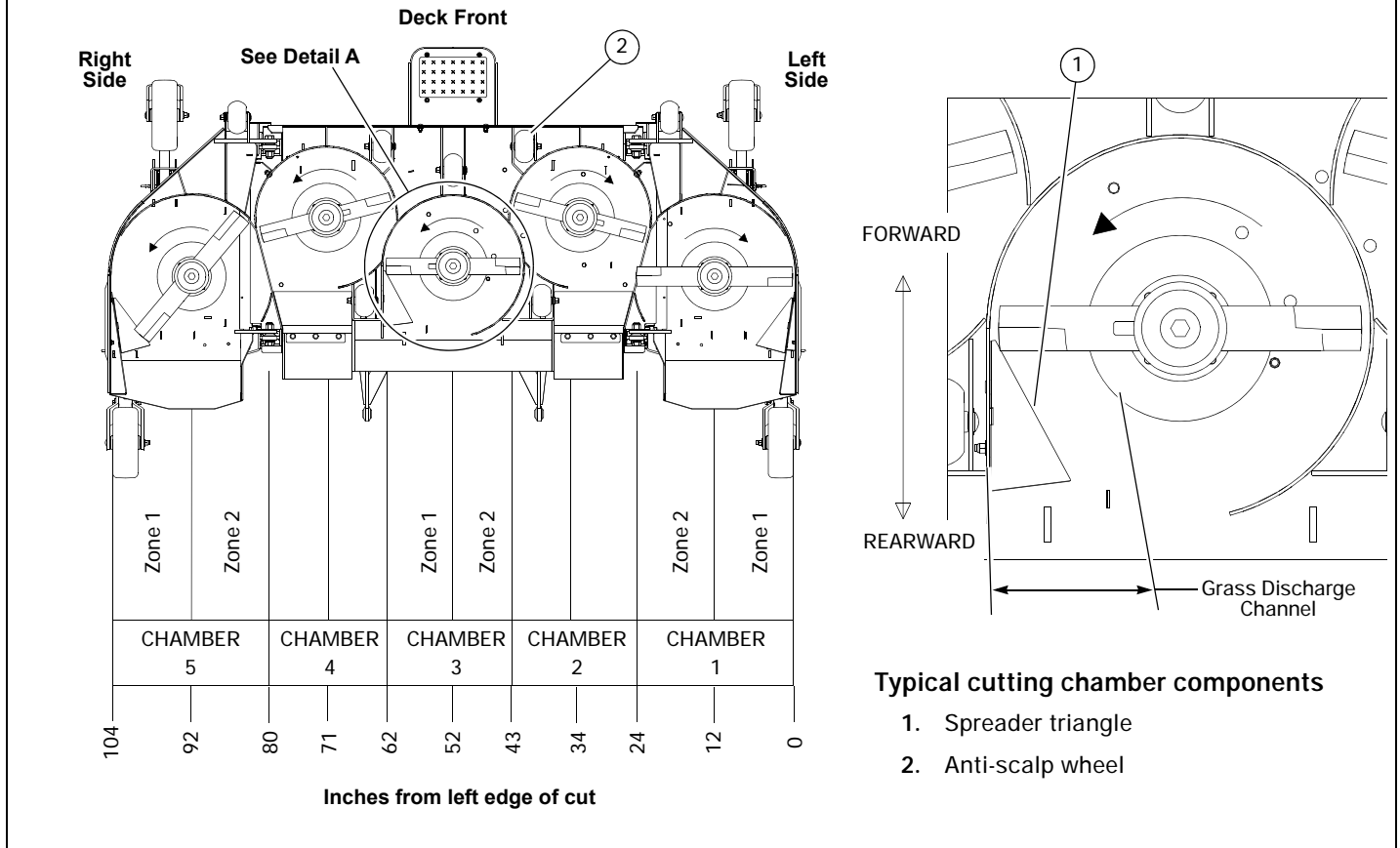

INDEX

	PAGE		PAGE
Air Restriction Indicator	5-4	Maintenance Precautions	2-3
Avoid Acid Burns	2-4	Maintenance Schedule	8-1
Avoid Fire Hazards	2-2, 2-3	Mower Blade Maintenance	6-4
Belts	4-6, 6-6	Mower Blade Removal	6-5
Blades	6-4	Operate Machine Safely	2-2
Center Deck Belt Routing & Tensioning	6-7	Operation Precautions	2-2
Center Deck Belts Adjustment	6-6	Park Brake Adjustment	4-5
Center Deck Leveling	6-1	Pre-operation Precautions	2-1
Center Deck to Side Deck Belt Routing & Tensioning	6-8	Prepare for Emergencies	2-3
Checking the Deck Lift Circuit Pressure	4-7	Prevent Battery Explosions	2-3
Control Lever Stops	4-2	Pump Replacement	4-11
Cut Quality and Discharge Management	9-3	Pump Test Procedure	4-9
DDC20 Pump Startup Procedure	4-10	Safe Servicing Practices	2-1
Deck Functionality	9-4	Service Program	1-1
Deck Leveling	6-1	Side Deck Belt Adjustment	6-6
Deck Troubleshooting	6-6	Side Deck Leveling	6-1
Deck Zone Chart	9-5	Special Torques	3-1
Electrical Schematic – Main Mower Harness	7-1, 7-2, 7-3	Standard Torques	3-1
Electrical Schematic – Side Deck Harness	7-4	Start Engine Safely	2-2
Engine Air Filter	5-2	Steering Adjustments	4-1
Engine Oil and Filter	5-1	Steering Control Lever Adjustment	4-3
Fuel & Evaporative System Line Routings	5-4	Steering Control Lever Neutral Adjustment	4-1
Fuel Evaporation System Filter	5-4	Steering Damper	4-3
Fuel Handling	2-1	Tapered Wheel Bearing Replacement	4-16
General Engine Maintenance	5-1	Test Procedure for DDC20 Pump	4-9
General Maintenance Precautions	2-2	Tires	4-18
Hydraulic Pump Belt Adjustment	4-6	Understand Correct Service	2-1
Hydraulic System	4-6	Understand Machine Operation	2-2
Maintenance Introduction	1-1	Warner Clutch Re-gap Adjustment Procedures	4-12
Maintenance Locator Chart	8-3	Warranty	1-1
		Wear Protective Clothing	2-2

