

Hustler® Raptor® X Hustler® Raptor® XL General Service Manual



HUSTLER®
ENGINEERING PERFORMANCE™

200 South Ridge Road
Hesston, Kansas
67062

WARNING

The engine exhaust from this product contains chemicals known to the state of California to cause cancer, birth defects or other reproductive harm.

NOTICE OF REQUIREMENT OF SPARK ARRESTER MUFFLER

This equipment may create sparks that can start fires around dry vegetation. California Public Resources Code Section 4442.6 provides that it is unlawful to use or operate an internal combustion engine on any forest-covered, brush-covered, or grass-covered land unless the engine is equipped with a spark arrester maintained in effective working order. A spark arrester is a device constructed of nonflammable materials specifically for the purpose of removing and retaining carbon and other flammable particles over 0.0232 of an inch in size from the exhaust flow of an internal combustion engine that uses hydrocarbon fuels or which is qualified and rated by the United States Forest Service. Other states or federal areas may have similar laws. The Operator Should Contact Local Fire Agencies For Laws or Regulations Relating to Fire Prevention Requirements. **THIS EQUIPMENT DOES NOT HAVE A SPARK ARRESTER AND YOU SHOULD CONTACT YOUR AUTHORIZED DEALER FOR THE PURCHASE OF A SPARK ARRESTER.**

Inspect spark arrester daily; replace every 500 hours or as needed.

The Engine Owner's Manual provides information regarding the U.S. Environmental Protection Agency (EPA) and the California Emission Control Regulation of emission systems, maintenance and warranty.

Keep Engine Owner's Manual with your unit. Should the Engine Owner's Manual become damaged or illegible, replace immediately. Replacements may be ordered per the information found in the Product Information section of the owner's manual.

Federal law and California State law prohibit the following acts or the causing thereof:

1. The removal or rendering inoperative by any person other than for purposes of maintenance, repair, replacement, of any device or element of design incorporated into any equipment for the purposes of emissions control prior to or after its sales or delivery to the ultimate purchaser or while it is in use, or
2. The use of the equipment after such device or element of design has been removed or rendered inoperative by any person.

Table of Contents

General Information	1-1
Hustler® Service Program	1-1
Maintenance Introduction	1-1
Warranty	1-1
Safety	2-1
Safe Servicing Practices	2-1
Pre-Operation Precautions	2-1
Operation Precautions	2-2
Operate Machine Safely	2-2
General Maintenance Precautions	2-2
Maintenance Precautions	2-3
Torque	3-1
Standard Torques	3-1
Special Torques	3-1
Power Unit Maintenance	4-1
Steering Adjustments	4-1
Hydraulic system	4-7
Tires	4-7
Engine Maintenance	5-1
General Engine Maintenance	5-1
Engine Oil and Filter	5-1
Engine Air Filter	5-1
Fuel Evaporation System Filter	5-2
Fuel and Evaporative System Line Routing	5-2
Engine RPM Settings	5-3
Deck Adjustments	6-1
Deck Leveling	6-1
Blades	6-1
Deck Belt	6-4
42" Deck Belt Routing	6-7
54" Deck Belt Routing	6-7
Electrical	7-1
Electrical Schematic — Kawasaki	7-1
Maintenance	8-1
Maintenance Locator Chart	8-2

Troubleshooting 9-1

GENERAL INFORMATION

Hustler® Service Program

This manual is part of a service package for the Hustler® Raptor® X and Raptor® XL mowers. Use of this manual in conjunction with other Hustler® mower and component manuals will provide the information necessary to service and maintain the Hustler® Raptor® X and Raptor® XL mower.

This General Service Manual is a service guide for use by Service Technicians. It provides the necessary information needed to perform normal maintenance requirements on these units.

The Parts Manual provides a complete parts listing for the unit. Use this manual when ordering parts.

The Operator's Manual provides fundamental operational information and operational safety that is needed when operating the mower.

The component manuals are furnished by the various manufacturers to be used for the troubleshooting and servicing of their components.

Maintenance Introduction

Regular maintenance is the best prevention for downtime or premature failure. The following pages contain suggested maintenance information and schedules which the operator/mechanic should follow on a routine basis.

Remain alert for unusual noises, they could be signaling a problem. Visually inspect the machine for any abnormal wear or damage. A good time to detect potential problems is while performing scheduled maintenance service. Correcting the problem as quickly as possible is the best insurance.

Clear away heavy build-up of grease, oil and dirt, especially in the engine compartment and under the seat platform areas; minute dust particles are abrasive to close-tolerance engine and hydraulic assemblies.

Daily inspect mower for grass clippings and wire and string tangles. The underside of the mower deck will collect a build-up of grass clippings and dirt, especially when grass is wet or has high moisture content. This build-up will harden, restricting blade and air movement and will probably show a lesser quality of cut. Therefore it should be removed routinely.

To do this it will be necessary to raise and block the deck, using jack stands or blocks, in the full up position and scrape the build-up from underneath.

Some repairs require the assistance of a trained service mechanic and should not be attempted by unskilled personnel. Consult your Hustler® Turf Equipment service center when assistance is needed.

Information included in this manual was current at the time of printing, but subsequent production changes may cause your machine to vary slightly in detail. Hustler® Turf Equipment reserves the right to redesign and change the machine as deemed necessary, without notification. If a change has been made to your machine which is not reflected in this service manual contact the Customer Service Department at Hustler® Turf Equipment for additional information.

Warranty

Warranty repair must be performed by a Hustler® Turf Equipment Authorized Dealer before warranty credit can be allowed.

SAFETY



This safety alert symbol is used to call attention to a message intended to provide a reasonable degree of PERSONAL SAFETY for operators and other persons during the normal operation and servicing of this equipment.

⚠ DANGER ⚠	– denotes immediate hazards which WILL result in severe personal injury or death.
---------------------------------------	--

⚠ WARNING ⚠	– denotes a hazard or unsafe practice which COULD result in severe personal injury or death.
--	---

Safe Servicing Practices

Refer to the *Safety Precautions* section of this manual for more service safety information.

Understand Correct Service

- ▲ Be sure you understand a service procedure before you work on the machine.
- ▲ Unauthorized modifications to the machine may impair the function and/or safety and affect machine life.
- ▲ If it is necessary to make checks with the engine running, always use two people - with the operator at the controls, able to see the person doing the checking.

Pre-Operation Precautions

Fuel Handling

- ▲ To avoid personal injury or property damage, use extreme care in handling fuel. Fuel is extremely flammable and the vapors are explosive.
- ▲ Observe usual fuel handling precautions:
 - Do not smoke while refueling. Extinguish all cigarettes, cigars, pipes and other sources of ignition.
 - **Do not remove fuel cap or fill tank with engine running or while engine is hot. Clean up any fuel spills.**

- Allow engine to cool before storing machine inside a building.
- Keep fuel away from open flame or spark and store machine away from open flame or spark or pilot light such as on a water heater or appliances.
- Use extreme care when handling gasoline and other fuels. They are extremely flammable and vapors are explosive. A fire or explosion from fuel can burn you and others and can damage property.
- Refuel outdoors. Never refuel or drain the fuel from the machine indoors or while in an enclosed trailer or other enclosed area.
- Never attempt to start engine when there is a strong odor of gasoline or diesel fuel fumes present. Locate and correct cause.
- Store fuel in an approved container and keep it out of the reach of children. Never buy more than a 30 day supply of fuel.
- Do not fill fuel containers inside a vehicle or on a truck or trailer bed with interior carpets or plastic truck bed liners. Always place fuel containers on the ground away from your vehicle before filling.
- When practical, remove gas or diesel fuel powered equipment from the truck or trailer and refuel the equipment with its wheels on the ground. If this is not possible, then refuel such equipment on the truck or trailer using a portable container and not a fuel dispenser nozzle. If a fuel dispenser nozzle must be used, keep the nozzle in contact with the rim of the fuel tank or container opening at all times until fueling is complete. Do not use a nozzle lock-open device.
- Never use gasoline or diesel fuel for cleaning parts.
- Read and observe safety precautions elsewhere in this manual.

- ▲ Gasoline and diesel fuel is harmful or fatal if swallowed.
 - Long-term exposure to vapors can cause serious injury and illness.
 - Avoid prolonged breathing of vapors.
 - Keep face away from nozzle and gas tank or fuel container opening.
 - Keep fuel away from eyes and skin.
 - If fuel is spilled on clothing, change clothing immediately.

Understand Machine Operation

- ▲ Only qualified and trained personnel should operate the equipment.

- ▲ Carefully read the operator's manual and all manuals furnished with the attachments. Learn the location and purpose of all controls, instruments, indicators and labels.

Wear Protective Clothing

- ▲ Do not operate or service the equipment while wearing sandals, tennis shoes, sneakers, shorts or any type of loose fitting clothing. Long hair, loose clothing or jewelry may get tangled in moving parts. Always wear long pants, safety glasses, ear protection and safety shoes when operating or servicing this machine.
- ▲ Always wear adequate eye protection when servicing the hydraulic system and battery, or when grinding mower blades and removing accumulated debris.
- ▲ Prolonged exposure to loud noise can cause impairment or loss of hearing.
 - Always wear adequate ear protection, such as earplugs, when operating this equipment as prolonged exposure to uncomfortable or loud noises can cause impairment or loss of hearing.
 - Do not wear radios or music headphones while operating the machinery. Safe operation requires your full attention.

Operation Precautions

Avoid Fire Hazards

- ▲ Clean flammable material from machine. Prevent fires by keeping engine compartment, top of deck, exhaust area, battery, hydraulic lines, fuel line, fuel tank and operator's station clean of accumulated trash, grass clippings, and other debris. Always clean up spilled fuel and oil.

Start Engine Safely

- ▲ Avoid possible injury or death from machine runaway.
- ▲ Do not start engine by shorting across starter terminals.
- ▲ Before you start the engine:
 - Sit on the operator's seat.
 - Move control levers to the neutral/brake position.

Operate Machine Safely

- ▲ Refer to the unit's operator's manual for complete safety information on safe machine operation.
- ▲ Always maintain a safe distance from people and pets when mowing
- ▲ Always be aware of what is behind the machine before backing up.
- ▲ Never leave machine unattended with ignition key in switch, especially with children present.
- ▲ Follow daily and weekly checklists, making sure hoses are tightly secured and bolts are tightened.

- ▲ Always keep engine and machine clean, removing accumulated dirt, trash and other material from machine.
- ▲ Never put hands or feet under any part of the machine while it is running.
- ▲ Never attempt to start engine when there is a strong odor of gasoline fumes present. Locate and correct cause.
- ▲ Keep all safety shields and covers in place, except for servicing.
- ▲ Do not touch hot parts of machine.

General Maintenance Precautions

- ▲ Repairs or maintenance requiring engine power should be performed by trained maintenance personnel only.
- ▲ Never run the engine in an enclosed area unless exhaust is vented to the outside. Exhaust gases contain carbon monoxide which is an odorless and deadly poison.
- ▲ Unless specifically required, **DO NOT** have the engine running when servicing or making adjustments to the mower.
 - Park the mower on level ground
 - Disengage the deck clutch.
 - Place the steering control levers in the park brake position.
 - Lower the deck.
 - Stop the engine.
 - Remove the ignition key.
 - Disconnect the negative battery cable.
 - Wait for all movement to stop before adjusting, cleaning or repairing.
 - Repairs or maintenance requiring engine power should be performed by trained maintenance personnel only.
 - To prevent carbon monoxide poisoning, operate the engine in a well ventilated area only.
 - Read and observe all safety warnings in this manual.
- ▲ Before working on or under the deck, make certain engine cannot be accidentally started. Shut engine off, remove ignition switch key and disconnect negative battery cable for maximum safety.
- ▲ Except when changing or checking belt, **always** keep belt covers on mower deck for safety as well as cleanliness.
- ▲ Use a stick or similar instrument to clean under the mower making sure that no part of the body, especially arms and hands are under mower.
- ▲ Keep your machine clean and remove any deposits of trash and clippings, which can cause engine fires and

hydraulic overheating as well as excessive belt wear. Clean up oil or fuel spillage.

- ▲ Allow the mower, especially the engine, to cool in a well ventilated area before storing inside a building or other enclosure.
- ▲ Always wear adequate eye protection when servicing the hydraulic system and battery, or when grinding mower blades and removing accumulated debris.
- ▲ Never attempt to make any adjustments or repairs to the mower drive system, mower deck or any attachment while the engine is running or deck clutch is engaged.
- ▲ Exercise caution when releasing spring tension from any of the belt idlers or when working with any of the deck lift components.
- ▲ Never work under the machine or attachment unless it is safely supported with jack stands. Make certain machine is secure when it is raised and placed on the jack stands. The jack stands should not allow the machine to move when the engine is running and the drive wheels are rotating. **Use only certified jack stands.** Use only appropriate jack stands, with a minimum weight rating of 2000 pounds to block the unit up. Use in pairs only. Follow the instructions supplied with the vehicle stands.
- ▲ Keep nuts and bolts tight, especially the blade attachment bolts. Keep equipment in good working condition.
- ▲ Never tamper with safety devices. Check their proper operation regularly.
- ▲ Exercise caution when working under the deck as the mower blades are extremely sharp. Wrap the blade(s) or wear gloves and use extra caution when servicing them.
- ▲ Use original Hustler® replacement parts or parts that are equivalent in overall performance.
 - The mower may not comply with the appropriate safety standards if aftermarket parts, accessories, or attachments are used.

Maintenance Precautions

Avoid Fire Hazards

- ▲ Be prepared if an accident or fire should occur. Know where the first aid kit and the fire extinguishers are located and how to use them.
- ▲ Provide adequate ventilation when charging batteries.
- ▲ Do not smoke near battery.
- ▲ Never check fuel level with an open flame.
- ▲ Never use an open flame to look for leaks anywhere on the equipment.
- ▲ Never use an open flame as light anywhere on or around the equipment.

- ▲ When preparing engine for storage, remember that fuel stabilizer is volatile and therefore dangerous. Seal and tape openings after adding the inhibitor. Keep container tightly closed when not in use.
- ▲ Inspect electrical wiring for worn or frayed insulation. Install new wiring if wires are damaged.

Prepare for Emergencies

- ▲ Be prepared if a fire starts.
- ▲ Keep a first aid kit and fire extinguishers available.
- ▲ Keep emergency numbers for doctor, ambulance service, hospital, and fire department near the telephone.

Prevent Battery Explosions

- ▲ Battery posts, terminals, and related accessories contain lead and lead compounds, chemicals known to the State of California to cause cancer and reproductive harm. Wash hands after handling.
- ▲ Charge batteries in an open well-ventilated area, away from sparks and flames. Unplug charger before connecting or disconnecting from battery. Wear protective clothing and use insulated tools.
- ▲ Avoid skin and clothing contact with battery acid.
 - Always wear eye protection when checking the battery, acid can cause serious injury to skin and eyes. If contact occurs, flush area with clean water and call physician immediately. Acid will also damage clothing.
 - Do not drink the battery electrolyte.
 - Do not allow open flame near the battery when charging.
 - Hydrogen gas forms inside the battery. This gas is both toxic and flammable and may cause an explosion if exposed to flame. Always **disconnect** the negative (black) battery cable(s) before disconnecting the positive (red) cable(s). Always **connect** the positive (red) battery cable(s) before connecting the negative (black) cable(s).
 - Do not overfill battery.
 - Electrolyte may overflow and damage paint, wiring or structure. When cleaning the battery, use soap and water. Be careful not to get soap and water into the battery. Clean the battery terminals with a solution of four parts water and one part baking soda when they become corroded.
- ▲ Shorts caused by battery terminals or metal tools touching metal mower components can cause sparks. Sparks can cause a battery gas explosion which will result in personal injury.
 - Prevent the battery terminals from touching any metal mower parts when removing or installing the battery.
 - Do not allow metal tools to short between the battery terminals and metal mower parts.

- ▲ Incorrect battery cable routing could cause damage to the mower and battery cables. This can cause sparks which can cause a battery gas explosion which will result in personal injury. Always **disconnect** the negative (black) battery cable(s) before disconnecting the positive (red) cable(s). Always **connect** the positive (red) battery cable(s) before connecting the negative (black) cable(s).

Avoid Acid Burns

- ▲ Sulfuric acid in battery electrolyte is poisonous. It is strong enough to burn skin, eat holes in clothing and cause blindness if splashed in eyes.

Avoid the hazard by:

- Filling batteries in a well-ventilated area.
- Wearing eye protection and rubber gloves.

- Avoiding breathing fumes when electrolyte is added.
- Avoiding spilling or dripped electrolyte.

If you spill acid on yourself:

- Flush your skin with water.
- Apply baking soda or lime to help neutralize the acid.
- Flush your eyes with water for 10-15 minutes. Get medical attention immediately.

If acid is swallowed:

- Drink large amounts of water or milk.
- Then drink milk of magnesia, beaten eggs or vegetable oil.
- Get medical attention immediately.

TORQUE

Standard Torques

The following chart lists the standard torque values for the threaded fasteners found in this manual. Torque all cap screws, nuts and set screws to these values unless a different torque is shown in the *Special Torques* section.

Size	ft-lbs	N•m	Size	ft-lbs	N•m
#10	32.4 IN.-LBS.	3.6	M3	12 IN.-LBS.	1.3
.250	98.4 IN.-LBS.	11.1	M4	26.4 IN.-LBS.	3
.312	204 IN.-LBS.	23	M5	54 IN.-LBS.	6.1
.375	30	40	M6	92.4 IN.-LBS.	10.4
.438	48	65	M8	222 IN.-LBS.	25
.500	73	99	M10	37	50
.562	105	143	M12	64	87
.625	145	200	M14	103	140
.750	260	350	M16	160	215
.875	420	565	M20	320	435

Special Torques

Description	ft-lbs	N•m
Drive wheel axle bolt ¹	30	40
Blade spindle bolt top	73	99
Blade spindle bolt bottom	118	160
Electric clutch mounting bolt ²	47	63.7
Front wheel axle bolt	Tighten the nut, then back it off until the wheel spins freely.	
Transaxle pump pulley nut	50	67.8

NOTE:

1. **Drive wheel axle bolt only** – It is recommended that these be checked after the first 2 hours of operation and every 40 hours and following removal for repair or replacement.
2. If clutch mounting bolt is loosened or removed, do not re-use. Replace with a new bolt. Use only hand tools to install this fastener.



Particular attention must be given to tightening the drive wheel lug nuts and blade spindle bolts. Failure to correctly torque these items may result in the loss of a wheel or blade, which can cause serious damage or personal injury.

POWER UNIT MAINTENANCE

Steering Adjustments

Steering control lever neutral adjustment

The mower's steering has been factory adjusted to eliminate creeping when the steering control levers are in the neutral position. However, should the mower begin to creep, the steering control lever linkage can be adjusted.

Before considering any adjustment, check the tire air pressure. Unequal tire pressure will cause the mower to drift to one side. Refer to tire pressure information in the *Tire* section for detailed information.

NOTE: Proper park brake adjustment must be completed before the steering control lever neutral adjustment can be done. Refer to the *Park Brake Spring Adjustment* section for detailed information.

Fine adjustment to the unit's steering is made with the transmission's control rod.

Neutral is properly adjusted when the steering control levers are in the park brake position and the transmissions do not "whine".

If this occurs, the steering control linkage may be adjusted as follows:

WARNING

Never work under the machine or attachment unless it is safely supported with jack stands.

- Make certain machine is secure when it is raised and placed on the jack stands.
- Use **only certified jack stands**. Use only appropriate jack stands, with a minimum weight rating of 2000 pounds (907 kg) to block the unit up.
- Use in pairs only.
- Follow the instructions supplied with the jack stands.
- The jack stands should not allow the machine to move when the engine is running and the drive wheels are rotating.
- Do not allow the wheels to come in contact with the floor or any object that would permit the unit to propel itself.
- To prevent injury stay clear and exercise caution when rotating the wheels.

WARNING

Keep hands, hair, clothing, etc., clear of the pulleys on top of the transmissions. Exercise extreme caution.

WARNING

Untrained maintenance personnel should never attempt to make any adjustments or repairs to the mower's drive system while the engine is running. **The following procedures should be performed by trained maintenance personnel only.**

1. Shut engine off, place steering control levers in the park brake position, disengage deck clutch, remove ignition switch key and disconnect negative battery cable before doing any adjustments.
2. Raise the rear of the mower and block with certified jack stands. Remove the rear wheels.
3. Chock the front tires.
4. Make sure both steering control levers are in the park brake position. Figure 4-1

Steering control levers in park brake position

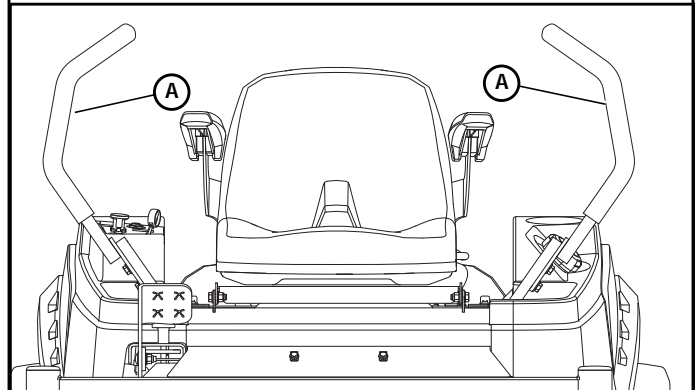

A. Steering control lever

Figure 4-1

5. Loosen the nuts adjacent to the steering bushing. Figure 4-2

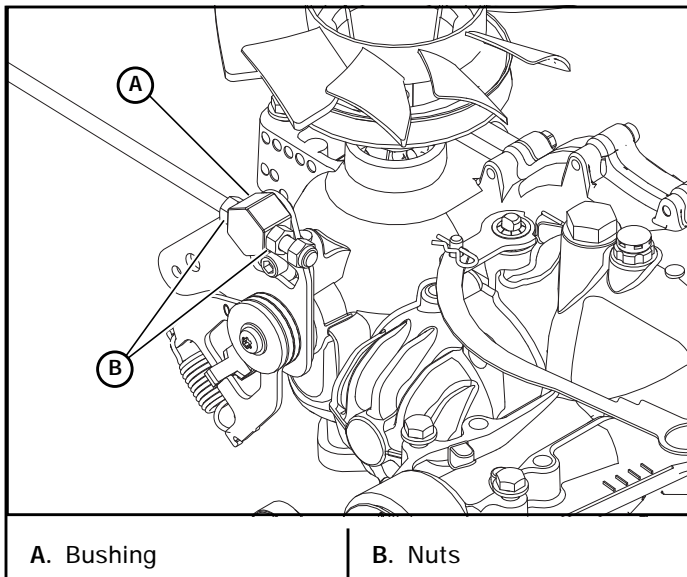

A. Bushing

B. Nuts

Figure 4-2

6. Place a clamp on the transmission pump arm as shown. Figure 4-3

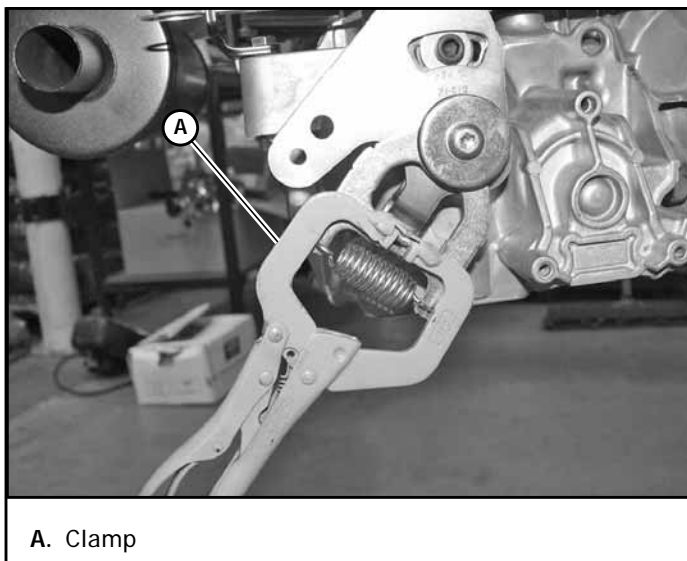

A. Clamp

Figure 4-3

7. Tighten the nuts against the steering bushing (Figure 4-2). Torque the rear nut to 14 ft-lbs (19 N•m). Verify that the steering arm is still in the park brake position and that the pump arms are still in the neutral position. Figure 4-2
8. Remove the clamp.
9. Move the steering control levers out of the park brake position and push fully forward. Verify that the pump arm does not bottom out against the stop on the transmission. Move the levers to the full reverse position and release. Verify that the levers return near to the neutral position.
10. Tighten the jam nut and torque to 14 ft-lbs (19 N•m).
11. The steering control levers should be adjusted so that they align vertically with each other when in the neu-

tral position. The space between the ends of the steering control handles should be $1.50" \pm .25"$ ($38.1 \text{ mm} \pm 6.35 \text{ mm}$) Figure 4-4

12. Check to make sure all tools or obstructions are removed from under the mower.
13. Re-install the rear wheels. Torque drive wheel axle bolts to 30 ft-lbs (40 N•m)
14. Raise the rear of the mower and remove the jack stands. Lower the mower.
15. Re-attach the negative battery cable.
16. Close the seat platform.

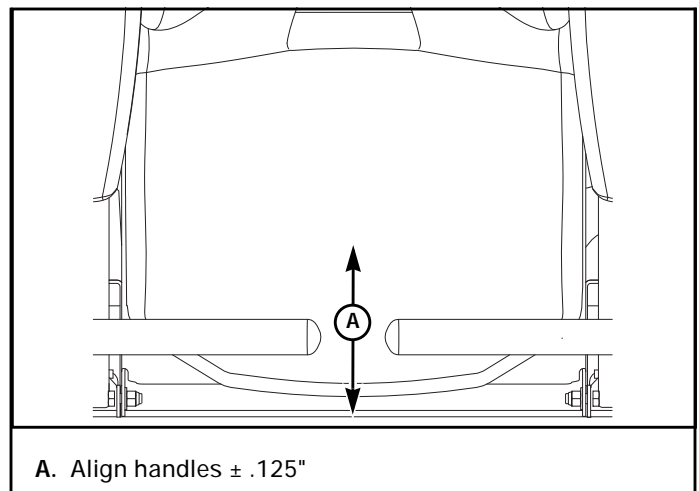

A. Align handles $\pm .125"$

Figure 4-4

Control lever stops adjustment

WARNING ⚠

Keep hands, hair, clothing, etc., clear of the rotating drive wheels/hubs during this process. Exercise extreme caution.

The steering control lever stops may be adjusted to help drive straight when the steering control levers are pushed forward against the stops.

NOTE: To adjust the control lever stops it will be necessary for the mower to be operated in an open area that allows for adequate maneuvering.

1. Check tire pressures (8–12 psi) to make certain the drive tires are inflated to the same pressure.
2. With the operator on the seat, start the engine and move both steering control levers to the full forward position.
3. Drive straight to determine if the drive wheels are rotating equally or if one is faster than the other. If the wheels are not operating at the same speed, determine which side is rotating faster.

4. Shut engine off and place the steering control levers in the park brake position. Raise the seat and seat platform. Figure 4-5

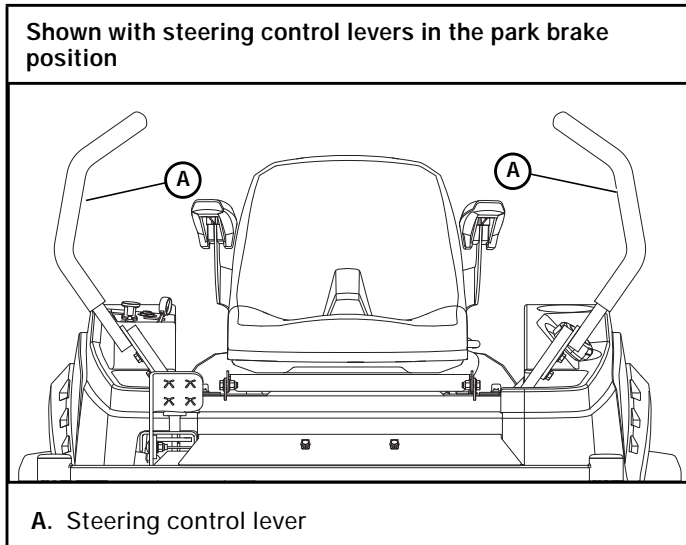

Figure 4-5

5. On the side that is going the slowest, locate the lower cap screw and jam nut on the back side of the steering control lever bracket. Figure 4-6

NOTE: It may be necessary to adjust the steering handles to allow space between the handle and the back of the seat platform. If the handles are adjusted for operator comfort and they are too far forward, they may contact the back of the seat platform. The handles can be re-adjusted for the operator after this adjustment is completed. Figure 4-7

6. Loosen the cap screw and jam nut.
7. Move the steering control lever from the park brake position to the full forward position and hold in this position.
8. Turn the cap screw until it makes contact with the steering control lever.
9. Tighten the jam nut against the steering control lever.
10. Return the steering control lever to the park brake position.
11. With the operator on the seat, start the engine and move both steering control levers to the full forward position.
12. Drive straight to determine if the drive wheels are now rotating equally. If not then proceed to the next step.
13. Shut engine off and place the steering control levers in the park brake position.
14. On the side that is going the fastest, locate the lower cap screw and jam nut on the back side of the steering control lever bracket. Figure 4-6
15. Loosen the jam nut and turn the cap screw clockwise one full rotation.

16. With the operator on the seat, start the engine and move both steering control levers to the full forward position.
17. Repeat this procedure until both wheels are rotating at the same speed.

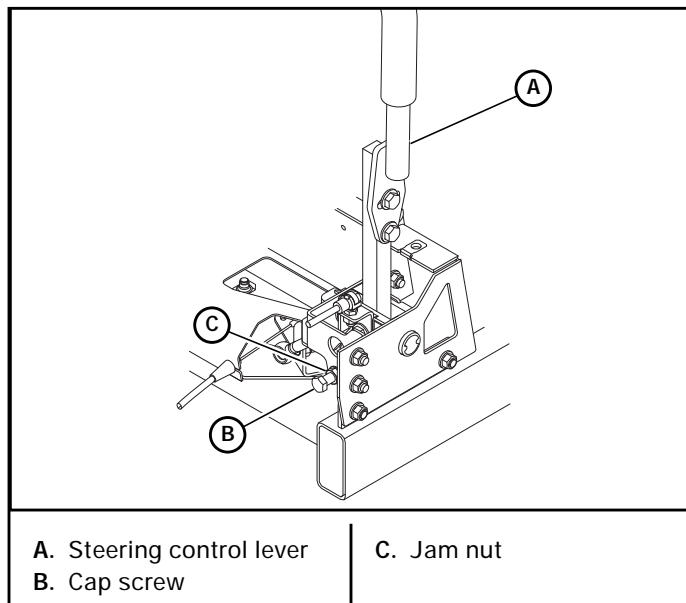

Figure 4-6

Transaxle Drive Belt

Inspect belts frequently for wear and serviceability. Replace a belt that shows signs of:

- severe cuts
- tears
- separation
- weather checking
- cracking
- burns caused by slipping.

Slight raveling of belt covering does not indicate failure, trim ravelings with a sharp knife.

Inspect the belt pulley grooves and flanges for wear. A new belt, or one in good condition, should never run against the bottom of the groove. Replace the pulley when this is the case, otherwise, the belt will lose power and slip excessively.

Never pry a belt to get it on a pulley as this will cut or damage the fibers of the belt covering.

Keep oil and grease away from belts, and never use belt dressings. Any of these will destroy the belt composition in a very short time.

Transaxle drive belt adjustment

The transaxle drive belt tension remains constant by means of a tension idler and spring. There is no tension adjustment of this belt. Figure 4-8



Figure 4-7

NOTE: Inspect the belt every month and replace as needed. Replace the belt every two (2) years.

WARNING ⚠

If the transaxle belt fails, loss of control will occur especially when operating on a slope. If you lose steering control while operating the machine, place the steering control levers in the park brake position immediately. Inspect the machine and involve your dealer to resolve the problem.

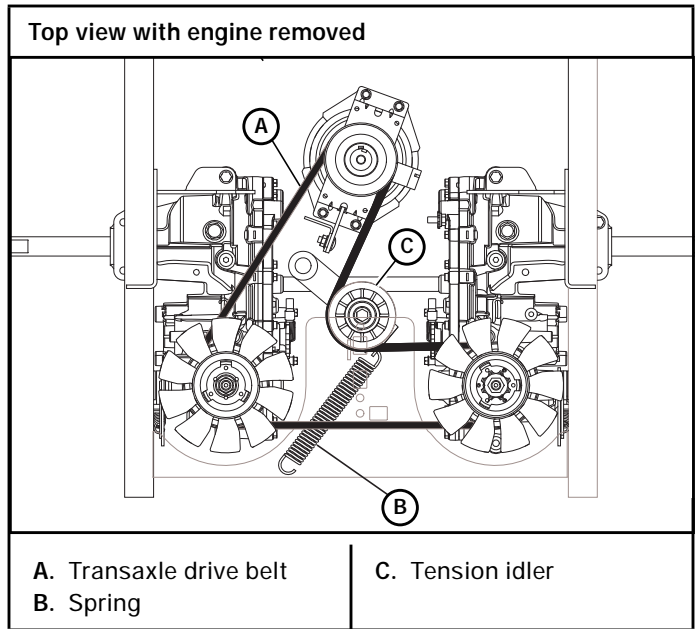

Figure 4-8

Transaxle drive belt replacement

WARNING ⚠

This procedure will require that the mower to be raised and blocked up off of the ground.

- Use only appropriate vehicle stands, with a minimum weight rating of 2000 pounds to block the unit up.
- Use in pairs only.
- Follow the instructions supplied with the vehicle stands.

WARNING ⚠

Allow the engine and muffler to cool before proceeding with the following procedure.

1. Park the mower on a flat surface and stop the engine.
 - Make sure deck clutch switch is in the down (OFF) position.
 - Place the steering control levers in the park brake position.
 - Remove ignition key. Make sure the blades are stopped before leaving seat.

- Disconnect the negative battery cable.
2. Lower the deck to the lowest setting.
 3. Remove the deck covers. Figure 4-9 & Figure 4-10

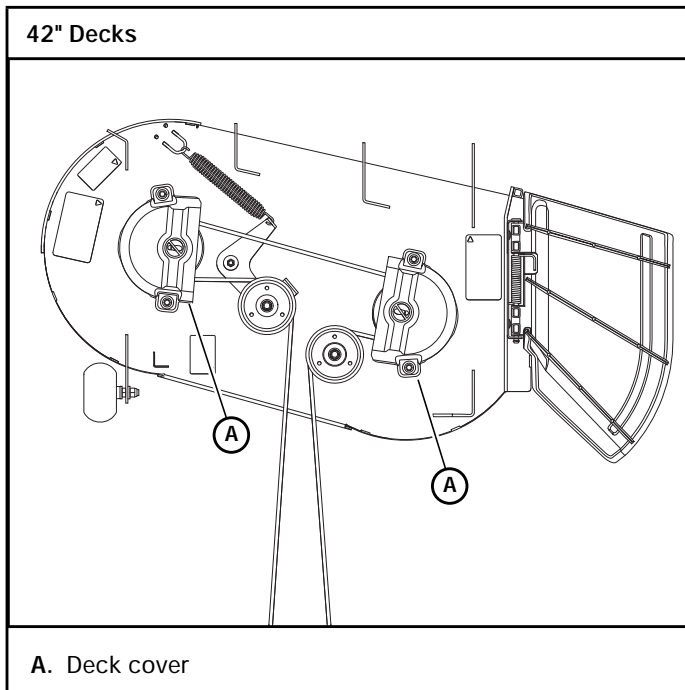

Figure 4-9

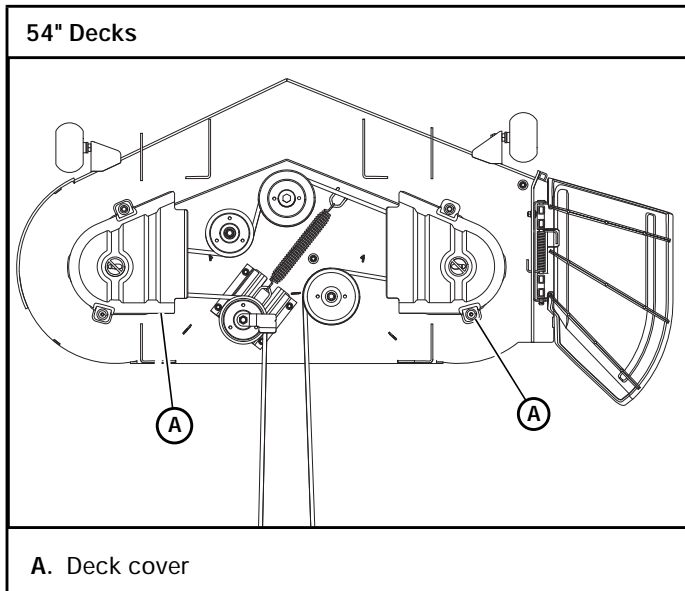

Figure 4-10

4. Grasp the belt at the two locations shown and pull the belt over the left spindle pulley. Figure 4-11 & Figure 4-12

NOTE: Do not remove the deck drive belt from the deck spindle pulleys. It will only need to be removed from the electric clutch pulley at the rear of the mower.

WARNING

Keep hands clear when pulling belt over the pulley to prevent pinching. Do not get hands or fingers between the pulley and belt.

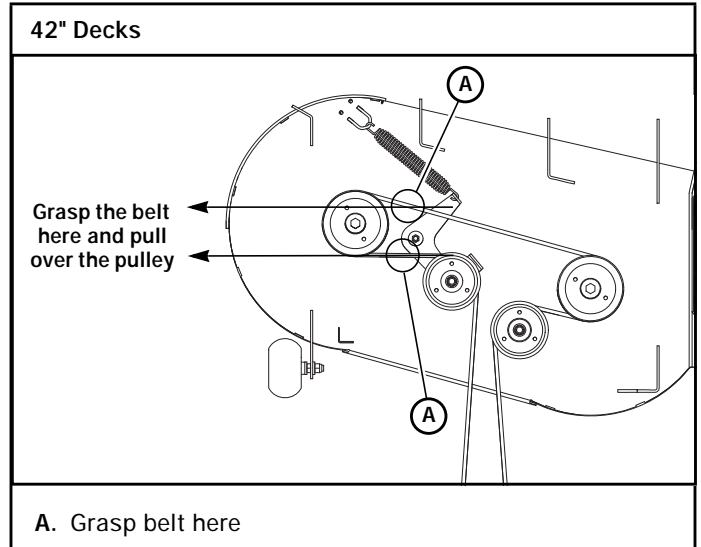

Figure 4-11

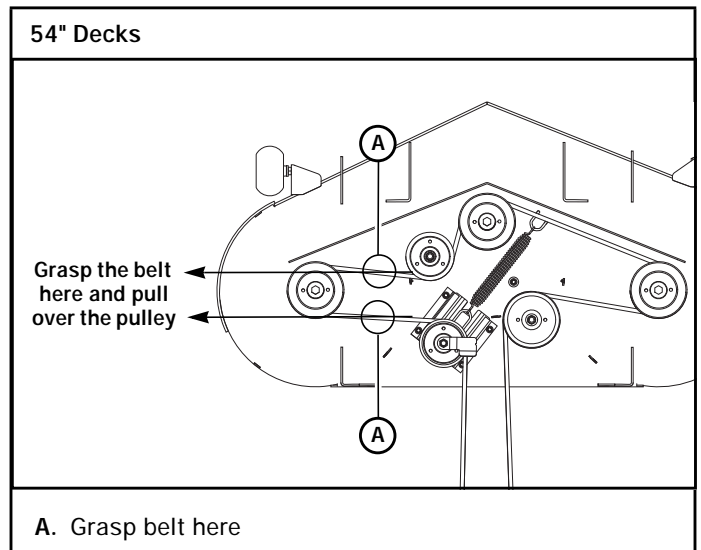

Figure 4-12

5. Raise the rear of the mower and block with certified jack stands.

- Remove the deck drive belt from the electric clutch pulley located on the engine shaft. Figure 4-13

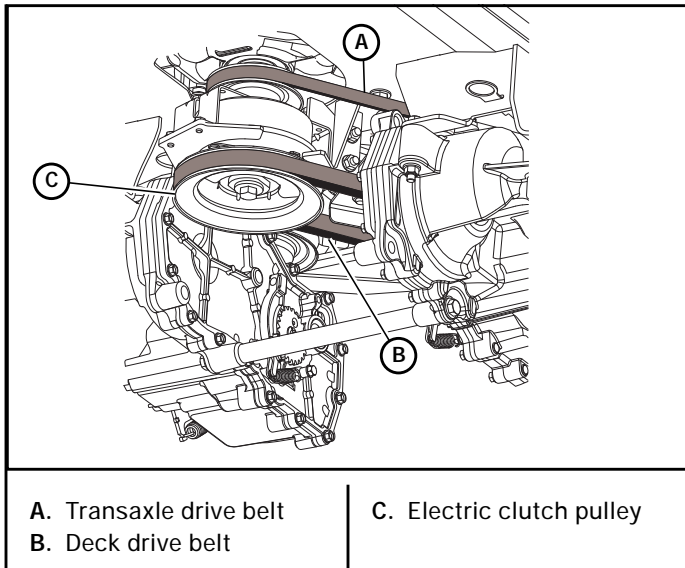

Figure 4-13

- Locate the tension idler spring. Securely clamp locking pliers onto the spring at the end located next to the front transmission support. Figure 4-14
- Release the transaxle drive belt tension, using the locking pliers, to remove the tension spring from the front transmission support. Swing the idler arm out of the way. Figure 4-14
- Remove the transaxle drive belt from the transaxle drive pulleys and the engine pulley. Figure 4-14

- Replace the transaxle drive belt and route it around the engine pulley and the transaxle drive pulleys. Figure 4-14

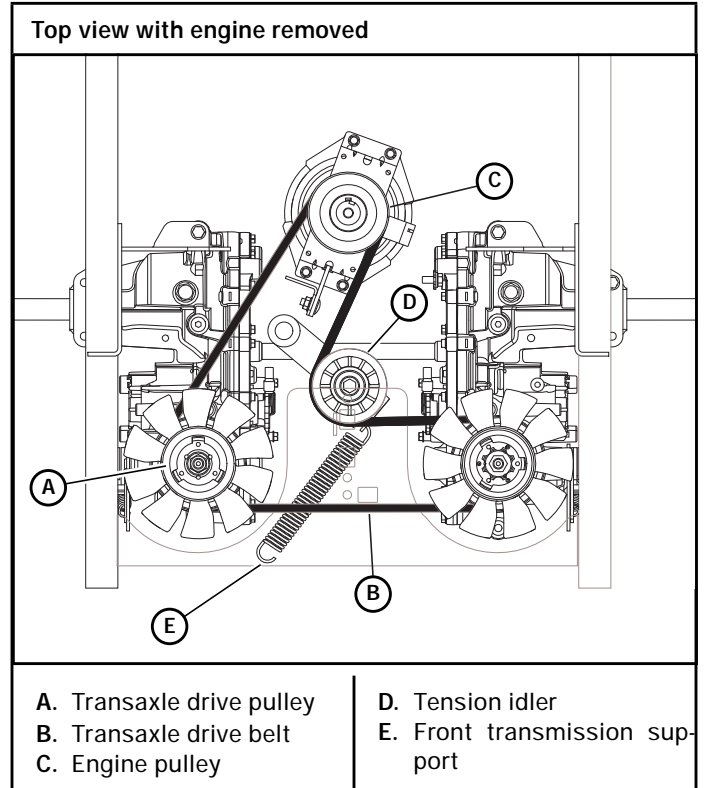

Figure 4-14

- Make sure the transaxle drive belt is routed correctly around the tension idler before attaching the tension spring. Using the locking pliers, re-attach the tension spring to the front transmission support to re-tension the transaxle drive belt. Remove the locking pliers from the tension spring. Figure 4-14
- Reroute the deck drive belt around the electric clutch pulley. Make certain the belt is routed properly around the spindle pulleys and stationary idler pulley(s). Figure 4-13
- Re-tension the deck drive belt by pulling on the deck belt at the locations shown. Slide the deck belt over the left spindle pulley. Figure 4-11 & Figure 4-12

WARNING	Keep hands clear when pulling belt over the pulley to prevent pinching. Do not get hands or fingers between the pulley and belt.
----------------	---

- Re-install the deck covers. Figure 4-9 & Figure 4-10
- Raise the rear of the mower and remove the jack stands.
- Lower the mower.
- Re-attach the negative battery cable.

Hydraulic system

The transmissions are sealed for life and do not require any scheduled maintenance.

⚠ WARNING ⚠	When washing the mower, direct the spray away (especially if using a power washer) from the transaxle's seals to prevent water intrusion and ensure component performance.
--	--

Tires

It is important for level mowing that the tires have the same amount of air pressure. The recommended pressures are:

Drive wheels 8–12 psi (55–83 KPa)

Front wheels 8–12 psi (55–83 KPa)

Only pneumatic tires are approved for use on this mower. Warranty claims will be denied on any mower equipped with non-pneumatic tires.

ENGINE MAINTENANCE

General Engine Maintenance

Detailed instructions and recommendations for break-in and regular maintenance are specified in the *Engine Owner's Manual*. Please refer to this manual for engine servicing, lubricating oil levels with quality and viscosity recommendations, bolt torques, etc. The engine warranty is backed by the engine manufacturer. Special attention should be paid to applicable data which will not be duplicated here.

Engine Oil and Filter



If the engine has been running and is up to operating temperature, allow the engine to cool before changing the oil. Engine and engine oil will be very hot, so be very careful when changing oil and wear the appropriate protective gear to avoid being burned or exposed to engine oil.

Check engine oil daily and after every 4 hours of operation. Mower must be on a level surface when checking oil. Refer to engine manual and maintenance schedule for oil capacities. Hustler® Motor Oil is recommended.

Initial oil and filter service should be performed between 5 and 10 hours. Thereafter every 40 – 60 hours or annually, whichever comes first. Condition of oil should be checked often and more frequent service for units used in adverse conditions may be required. Always use the engine manufacturer recommended viscosity and API classification of oil. Oils specially formulated for air cooled engines that include zinc are recommended. Retain service records to validate warranty.

IMPORTANT: After the new oil filter has been installed, clean up any oil which may have spilled onto the engine plate, muffler, and exhaust system.

Draining the engine oil:

1. Locate the oil drain valve on the lower right side of the engine.
2. Locate the oil drain hose that was supplied with the machine. Be sure to clean and clear it of debris that might block the flow of the engine oil. Figure 5-1
3. Attach one end of the hose onto the oil drain valve nipple. Make sure the hose is pushed all the way onto the valve. Figure 5-1
4. Position the loose end of the hose forward and down in front of the right side transmission so that it can drain into a suitable oil drain container.
5. With the hose in position, use a 10 mm wrench or socket and open the valve approximately 4 turns in the counterclockwise direction. Allow 10 minutes for engine oil to adequately drain.

6. After oil is drained, close the valve by turning it in the clockwise direction until it is fully closed.
7. Once the valve is closed, carefully remove the oil drain hose and clean up any spilled oil.

IMPORTANT: All oil drips or spills **must** be cleaned off of the engine plate, muffler, and exhaust system before operating the machine.

8. Clean the oil drain hose and store it appropriately. Figure 5-1

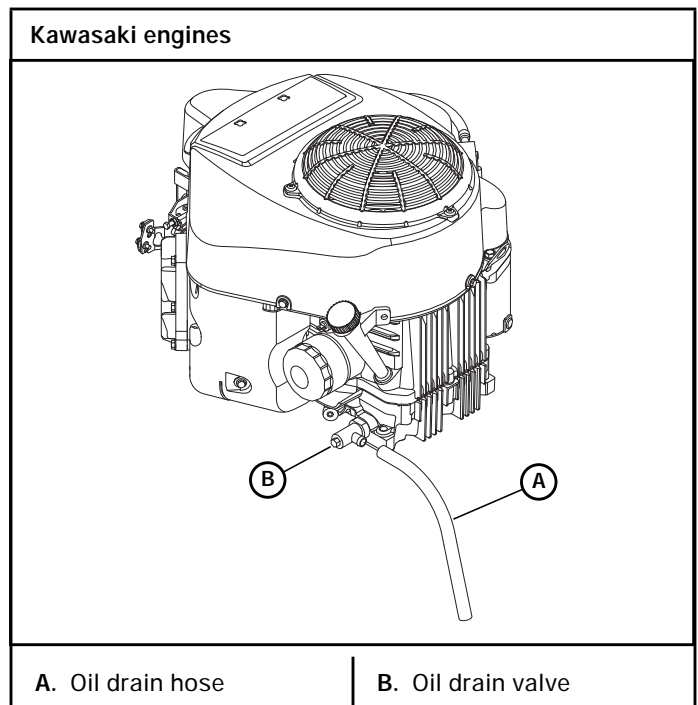
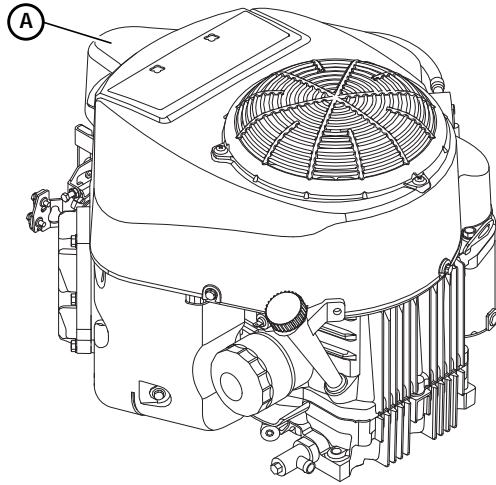

Figure 5-1

Engine Air Filter

Perform engine air filter maintenance per the *Maintenance Schedule* shown elsewhere in this manual. Figure 5-2

Kawasaki engine



A. Air filter cover

Figure 5-2

Fuel Evaporation System Filter

These mowers have a fuel evaporation system filter. This filter must be checked and replaced every 100 hours or annually whichever comes first. Figure 5-3

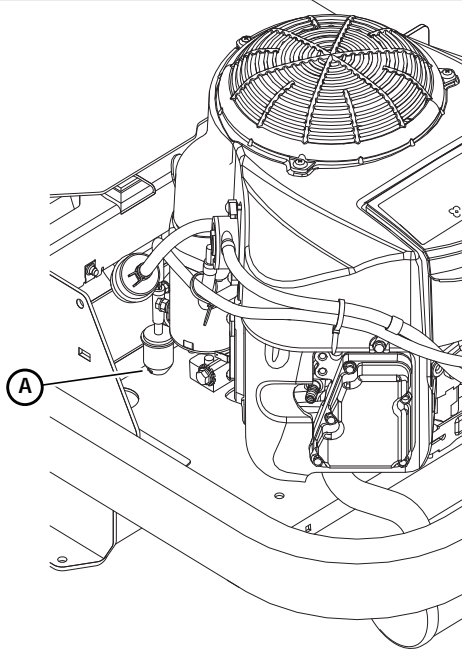

A. Fuel evaporation system filter

Figure 5-3

Fuel and Evaporative System Line Routing

These mowers have a fuel evaporative system installed. There are two different types of rubber hoses that are connected to the fuel tank. One is the fuel hose that is part of the fuel system. The other is the vapor line that is part of the fuel evaporative system.

The fuel hose is connected to the fuel tank as shown. It connects the fuel tank to the engine's fuel pump. Figure 5-4

The vapor lines are connected to the fuel tank as shown. They connect the fuel tank to the engine's vapor port. Figure 5-5

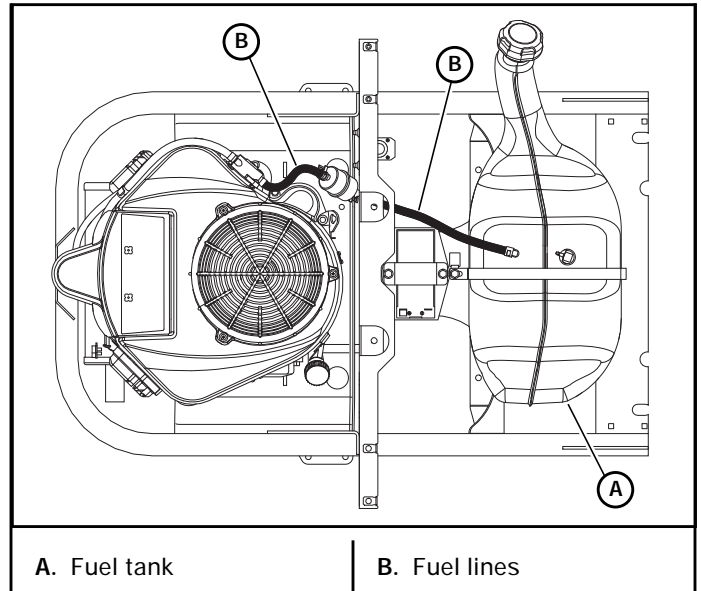

A. Fuel tank

B. Fuel lines

Figure 5-4

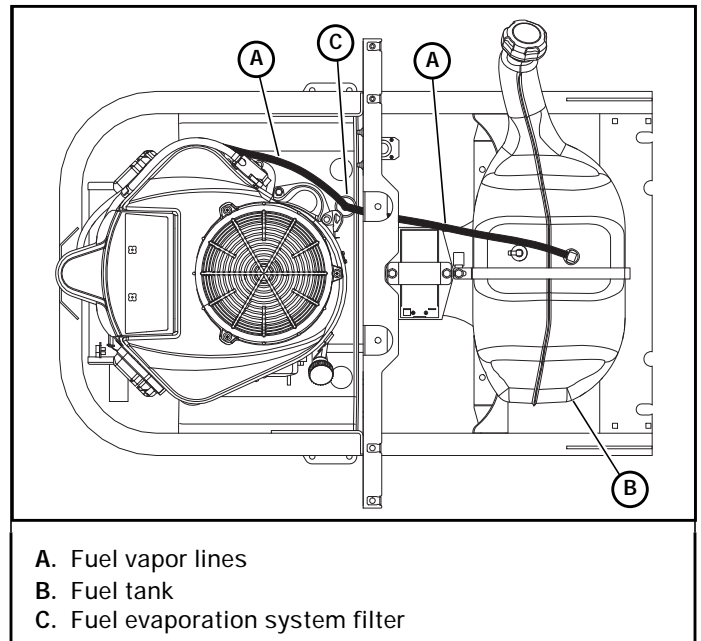

A. Fuel vapor lines

B. Fuel tank

C. Fuel evaporation system filter

Figure 5-5

Engine RPM Settings

The engine rpm's are set at the factory for maximum mowing efficiency. Occasionally it may be necessary to check and adjust the settings. The idle speeds should be set as follows:

KAWASAKI FR651 / FR691 / FR730	
ENGINE SPEED	
MODEL NO. ENDING WITH:	HIGH IDLE
Model NO. without extension Model NO. with US extension Model NO. with EX extension	3600 ± 50 rpm

NOTE: Model numbers may or may not end with an extension after the number. There are several different extensions that may be shown; i.e. EX or CE.

Example: 922222 (no extension)

922222 EX

922222 CE

922222 US

DECK ADJUSTMENTS

Deck Leveling

1. Park the mower on a hard, flat surface.
2. Check tire pressures (8–12 psi) to make certain the tires are properly inflated before starting to level deck.



Stop engine. Make sure deck clutch switch is **in the down (OFF) position**. Place the steering control levers in the park brake position before leaving the machine.

3. Raise the deck and lock it in the transport position using the transport lever.
4. Insert three (3) 3.00" blocks under the deck at the locations shown. Figure 6-1 & Figure 6-2

42" Decks

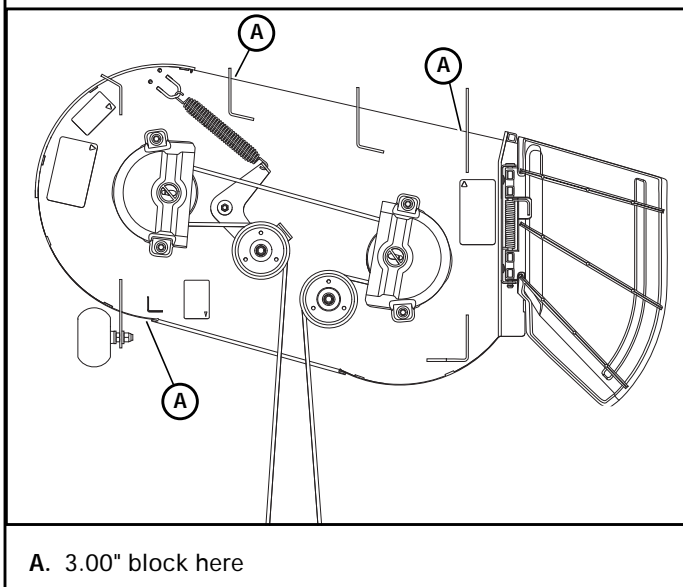

A. 3.00" block here

Figure 6-1

5. Lower the deck and place the deck height indicator pin in the 3.25" position. Figure 6-3
6. Loosen the three (3) deck leveling nuts at the (3) 3.00" block locations until all of the linkage rods are loose and the deck is sitting on the 3.00" blocks. The deck **must** be resting on the 3.00" blocks. Figure 6-1 & Figure 6-2
7. Adjust one (1) of the deck leveling nuts until the deck begins to lift off of the block. You should be able to slide the block out from under the deck without feeling any resistance. Figure 6-4

IMPORTANT: Raise the deck just enough so that the block can be moved without any resistance from the deck. Repeat at the other deck leveling positions.

54" Decks

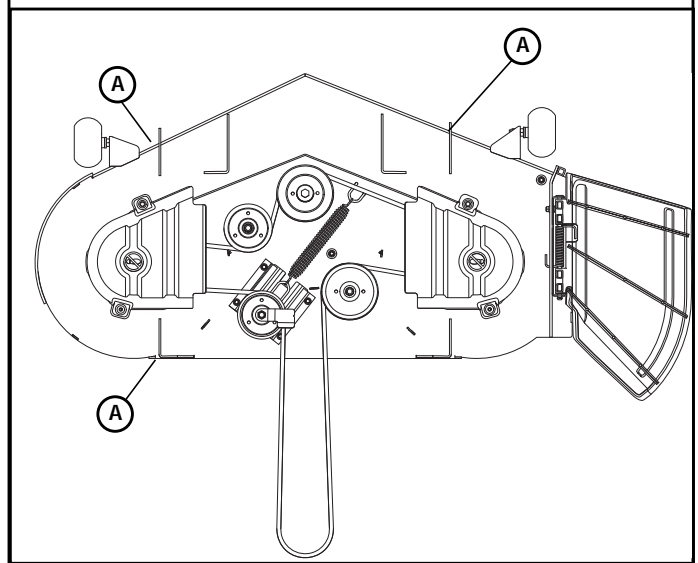

A. 3.00" block here

Figure 6-2

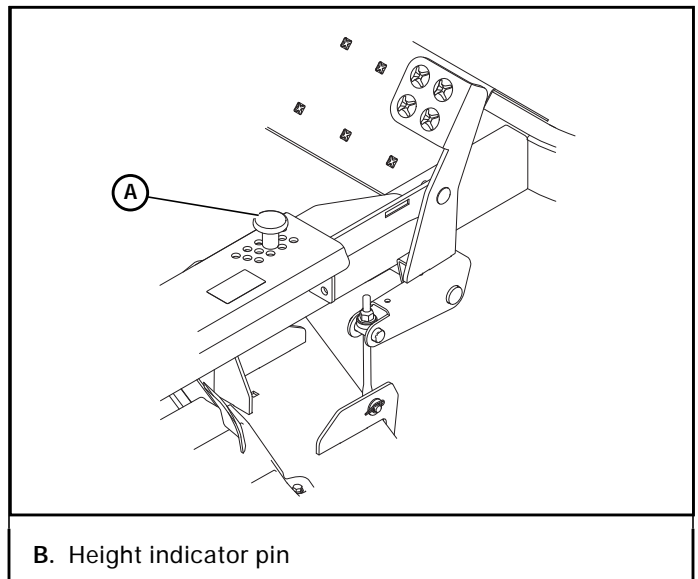

B. Height indicator pin

Figure 6-3

8. Adjust the right rear deck leveling nut until all the slack is taken up in this deck hanger.

Blades

Mower blade maintenance

Refer to the *Mower Blade Replacement* section for blade removal and installation.

Check the mower blades daily as they are the key to power efficiency and well groomed turf. Keep the blades sharp. A dull blade will tear rather than cut the grass, leaving a brown ragged top on the grass within a few hours. A dull blade also requires more power from the engine.

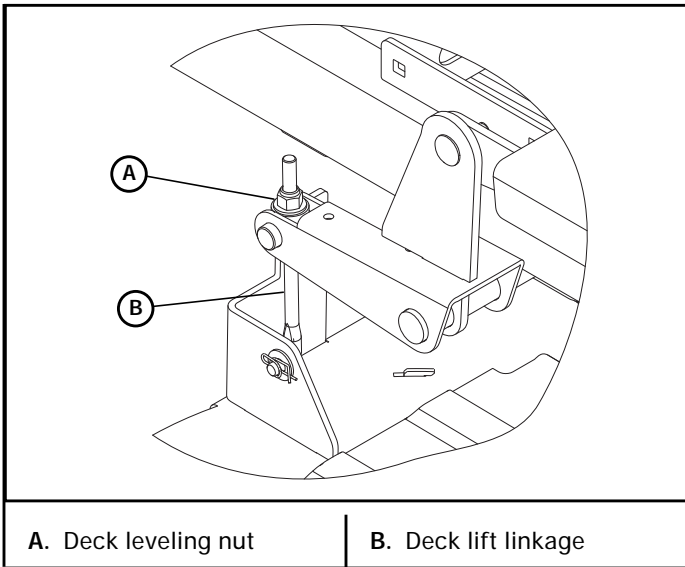

Figure 6-4

Replace any blade which is bent, cracked or broken.

WARNING

Never attempt to straighten a bent blade by heating, or weld a cracked or broken blade as the blade may break and cause serious injury. Replace worn or damaged blades.

WARNING

Repairs or maintenance requiring engine power should be performed by trained maintenance personnel only.

Unless specifically required, **DO NOT** have the engine running when servicing or making adjustments to the mower.

- Park the mower on level ground
- Disengage the deck clutch.
- Place the steering control levers in the park brake position.
- Lower the deck.
- Stop the engine.
- Remove the ignition key.
- Disconnect the negative battery cable.
- Block up mower when you **must** work under it.

Always check for blade damage if mower strikes a rock, branch or other foreign object during mowing!

WARNING

Always wear adequate eye protection when grinding mower blades.

WARNING

Mower blades are sharp and can cut. Wrap the blade(s) or wear gloves and use extra caution when servicing them.

Sharpen the blades on a grinder following pattern as shown (Figure 6-5). Touch-up sharpening can be done with a file.

After grinding the blades, check for balance. Blade balancing can be done by placing the blade on an inverted line punch or 5/8" bolt. A commercial balancing tool is also available through most hardware supply stores.

The blade should not lean or tilt. When spinning the blade slowly it should not wobble. Balance the blade before re-installing.

Lay the blade on a flat surface and check for distortion (Figure 6-6 & Figure 6-7). Replace any distorted blade.

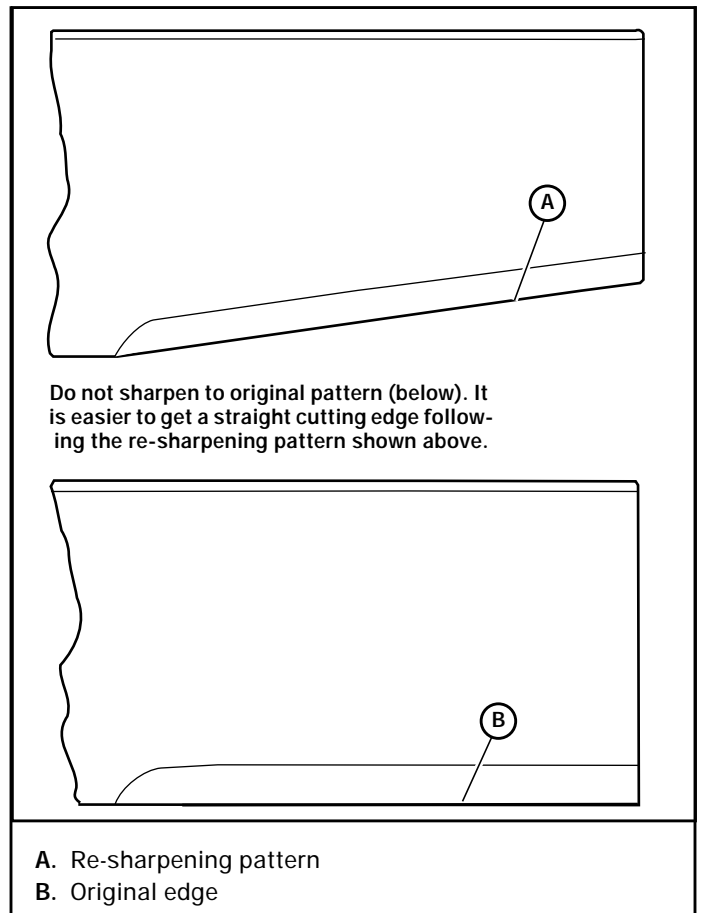

Figure 6-5

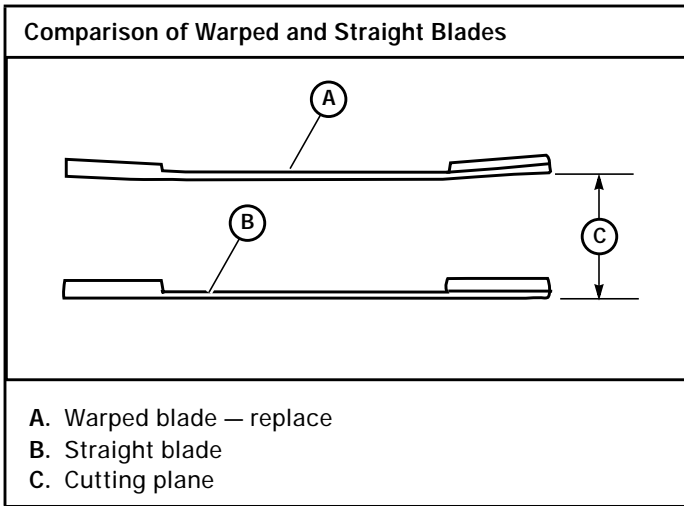

Figure 6-6

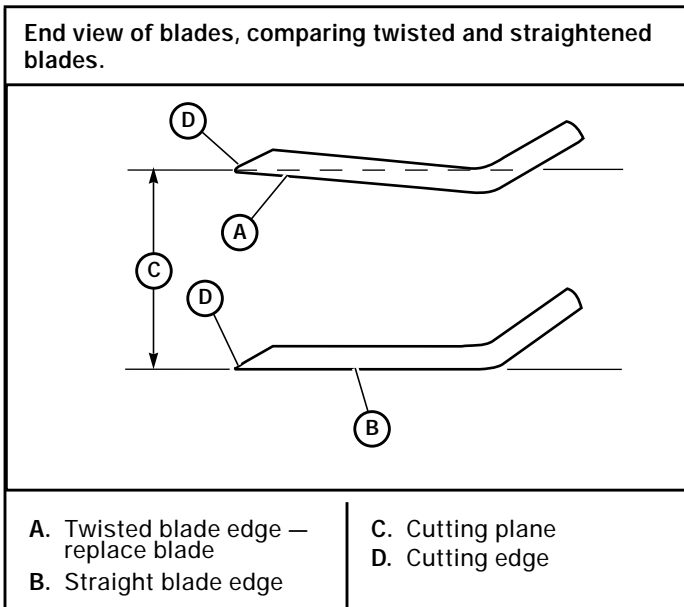

Figure 6-7

Mower blade replacement

WARNING ⚠

Never work under the machine or attachment unless it is safely supported with jack stands.

- Make certain machine is secure when it is raised and placed on the jack stands.
- Use **only certified jack stands**. Use only appropriate jack stands, with a minimum weight rating of 2000 pounds (907 kg) to block the unit up.
- Use in pairs only.
- Follow the instructions supplied with the jack stands.

1. Park the mower on a flat surface and stop the engine.
 - Make sure deck clutch switch is in the down (OFF) position.
 - Remove ignition key.

- Place the steering control levers in the park brake position.
 - Make sure the blades are stopped before leaving seat.
 - Disconnect the negative battery cable.
2. Raise the front of the unit and block with certified jack stands. This allows easier access to the blades under the deck.
 3. Install a blade lock tool (Excel part number 381442) over the two blades to prevent them from rotating. Figure 6-8

WARNING ⚠

Repairs or maintenance requiring engine power should be performed by trained maintenance personnel only.

Unless specifically required, DO NOT have the engine running when servicing or making adjustments to the mower.

- Park the mower on level ground
- Disengage the deck clutch.
- Place the steering control levers in the park brake position.
- Lower the deck.
- Stop the engine.
- Remove the ignition key.
- Disconnect the negative battery cable.
- Never work with blades while engine is running or deck clutch is engaged.

WARNING ⚠

Exercise caution when working under the deck as the mower blades are extremely sharp. Wearing gloves is advisable when working around or with the blades.

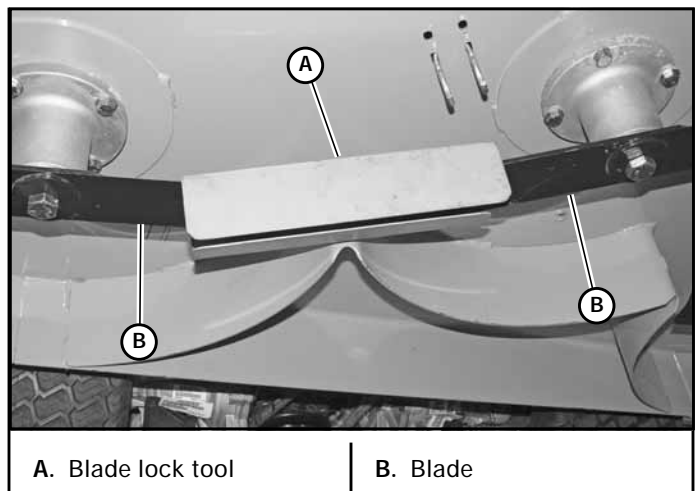

Figure 6-8

4. Use a 15/16" wrench to remove the 5/8" cap screw holding the blade to the spindle shaft.

NOTE: Only remove and install one blade at a time when using the blade lock tool (Excel part number 381442) as it requires two blades to work properly.

5. Inspect the blade for damage. If the blade is damaged, replace it. If the blade is not damaged, either sharpen it or replace it with a new blade or another sharpened used blade.

WARNING ⚠
Never attempt to straighten a bent blade by heating, or weld a cracked or broken blade as the blade may break and cause serious injury.

6. If sharpening the blade, refer to the *Mower blade maintenance* section for proper sharpening procedures.

WARNING ⚠
Always check for blade damage if mower strikes a rock, branch or other foreign object during mowing!

7. When attaching the blade to the spindle shaft do not re-use spindle bolts which have stripped, worn or undercut threads. Torque bolts on spindles to 118 foot-pounds (160 N•m) when reinstalling blades.

IMPORTANT: The blade sail (curved part) must be pointing upward toward the inside of the deck to ensure proper cutting.

WARNING ⚠
Rotate the blades after installation to ensure blade tips do not touch each other or sides of the mower.

8. Remove the blade lock.
9. Raise the front of the mower and remove the jack stands.
10. Lower the mower.
11. Re-attach the negative battery cable.

Deck Belt

Inspect belts frequently for wear and serviceability. Replace a belt that shows signs of:

- severe cuts
- tears
- separation
- weather checking

- cracking
- burns caused by slipping.

Slight raveling of belt covering does not indicate failure, trim ravelings with a sharp knife.

Inspect the belt pulley grooves and flanges for wear. A new belt, or one in good condition, should never run against the bottom of the groove. Replace the pulley when this is the case, otherwise, the belt will lose power and slip excessively.

Never pry a belt to get it on a pulley as this will cut or damage the fibers of the belt covering.

Keep oil and grease away from belts, and never use belt dressings. Any of these will destroy the belt composition in a very short time.

Deck belt adjustment

The spindle belt tension remains constant by means of a tension idler and spring. There is no tension adjustment of this belt. Figure 6-9 & Figure 6-10

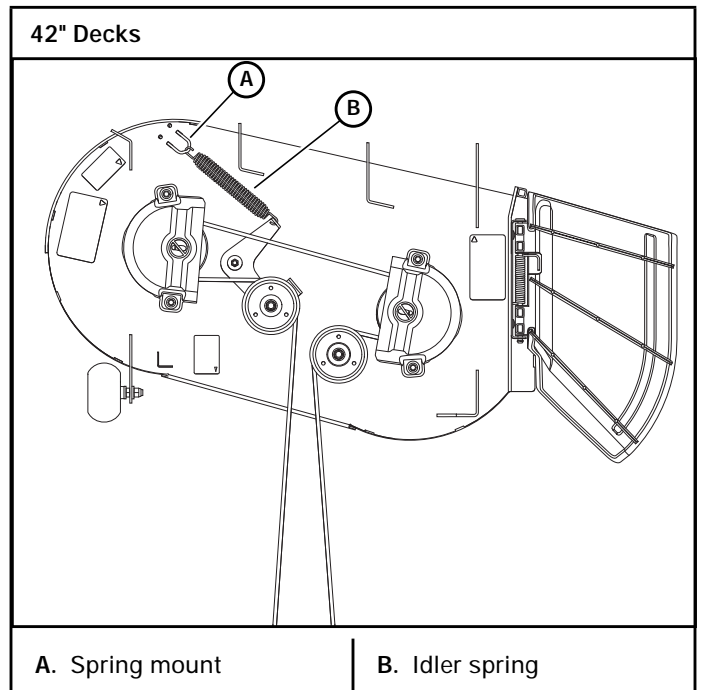

Figure 6-9

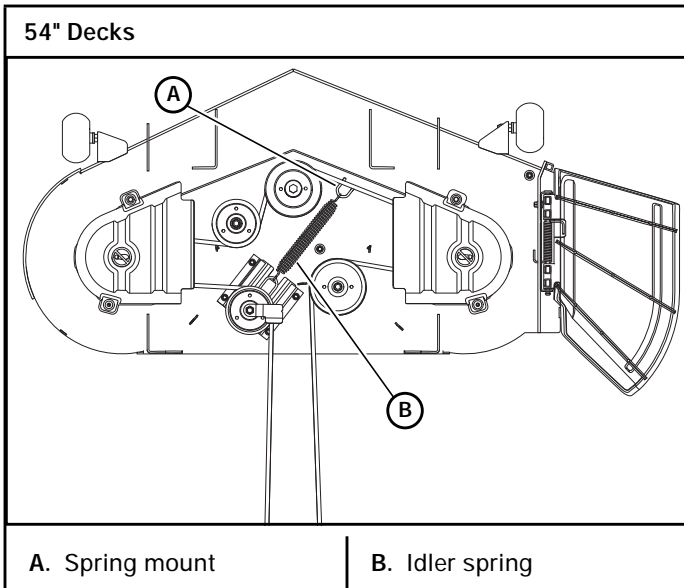

Figure 6-10

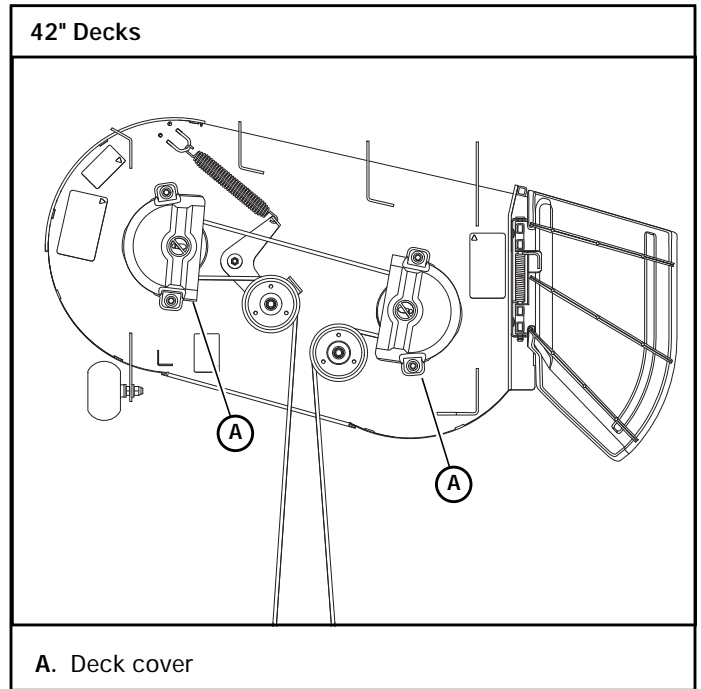

Figure 6-11

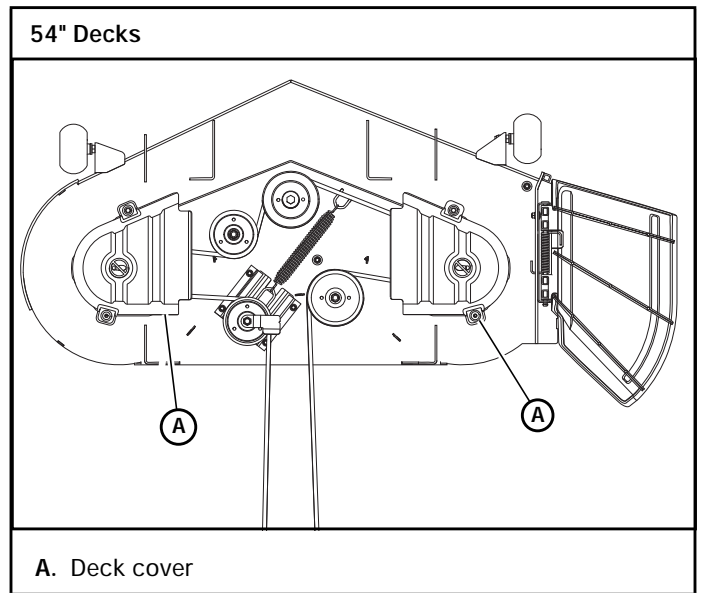

Figure 6-12

Deck belt replacement

WARNING Allow the engine and muffler to cool before proceeding with the following procedure.

WARNING Exercise caution when releasing spring tension from the belt idler.

1. Park the mower on a flat surface and stop the engine.
 - Make sure deck clutch switch is in the down (OFF) position.
 - Place the steering control levers in the park brake position.
 - Remove ignition key. Make sure the blades are stopped before leaving seat.
 - Disconnect the negative battery cable.
2. Lower the deck to the lowest setting.
3. Remove the deck covers. Figure 6-11 & Figure 6-12

4. Grasp the belt at the two locations shown and pull the belt over the left spindle pulley. Figure 6-13 & Figure 6-14

WARNING Keep hands clear when pulling belt over the pulley to prevent pinching. Do not get hands or fingers between the pulley and belt.

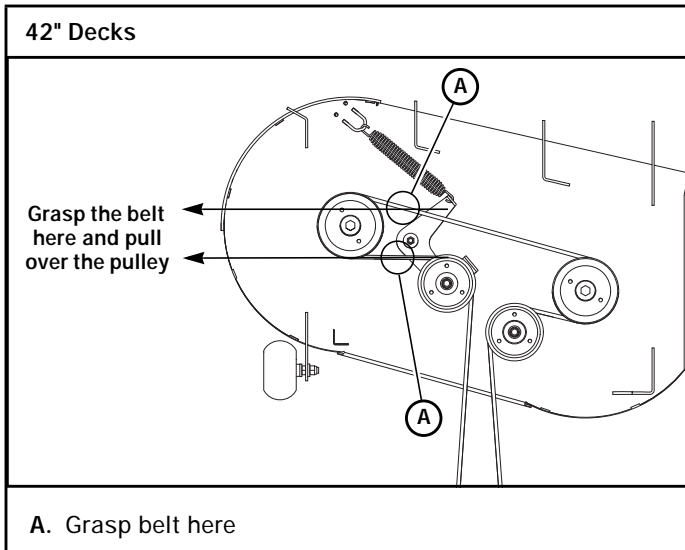

Figure 6-13

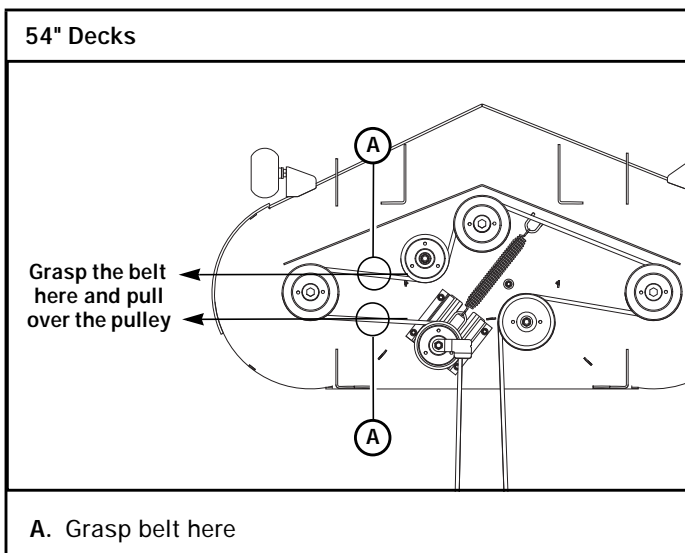

Figure 6-14

5. Remove the deck drive belt from the deck spindle pulleys and idler pulley.
6. Remove the deck drive belt from the electric clutch pulley located on the engine shaft. Figure 6-15

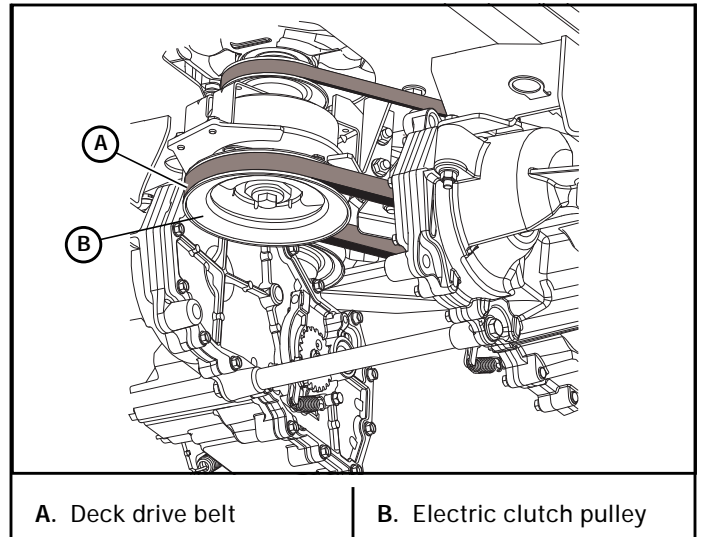

Figure 6-15

7. Route the new deck drive belt around the clutch pulley, spindle pulleys and stationary idler pulley. Make certain the belt is routed properly. Figure 6-16 & Figure 6-17
8. Re-tension the deck drive belt by pulling on the deck belt at the locations shown. Slide the deck belt over the left spindle pulley. Figure 6-13 & Figure 6-14

WARNING

Keep hands clear when pulling belt over the pulley to prevent pinching. **Do not** get hands or fingers between the pulley and belt.

9. Re-install the deck covers. Figure 6-11 & Figure 6-12
10. Re-attach the negative battery cable.

WARNING

Never operate the mower without the deck covers in place.

The following notes are the same for the different decks shown.

1. There is no tension adjustment of this belt.
2. Route belt as shown.

42" Deck Belt Routing

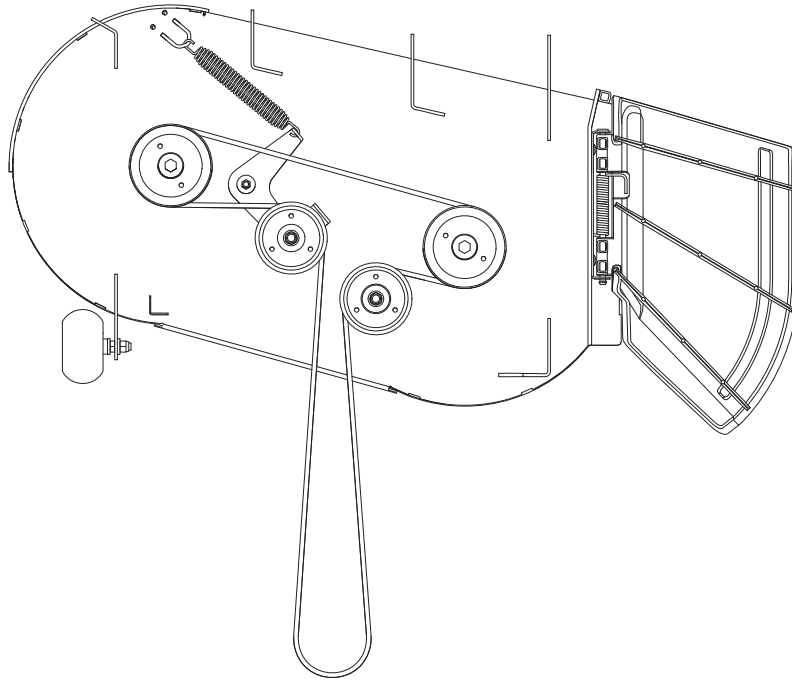

Figure 6-16

54" Deck Belt Routing

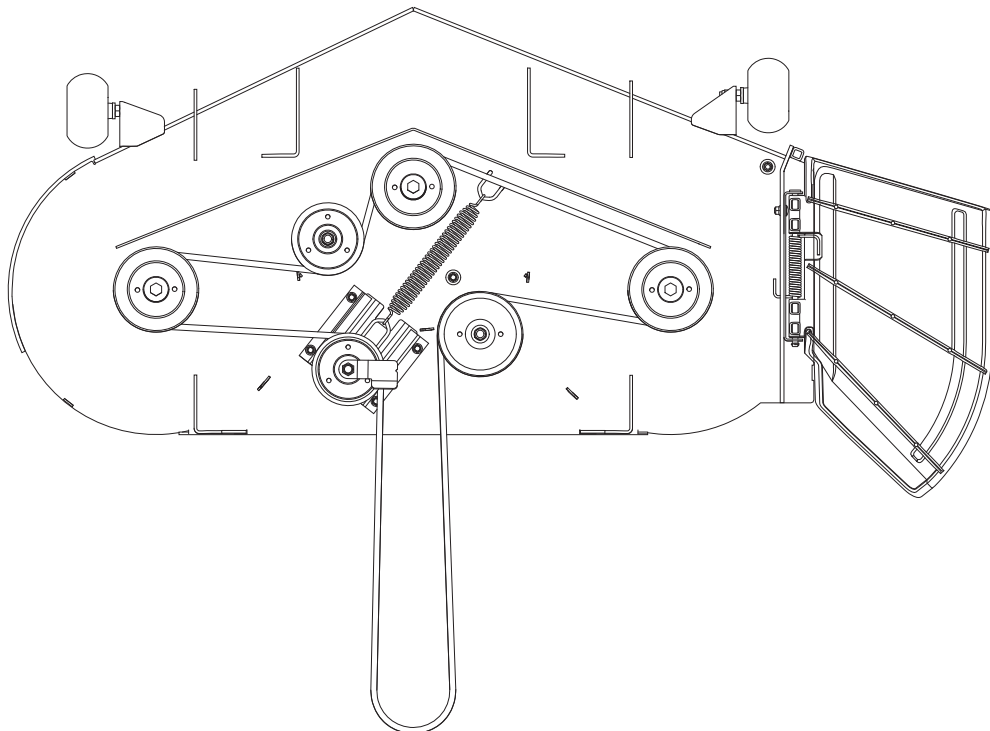
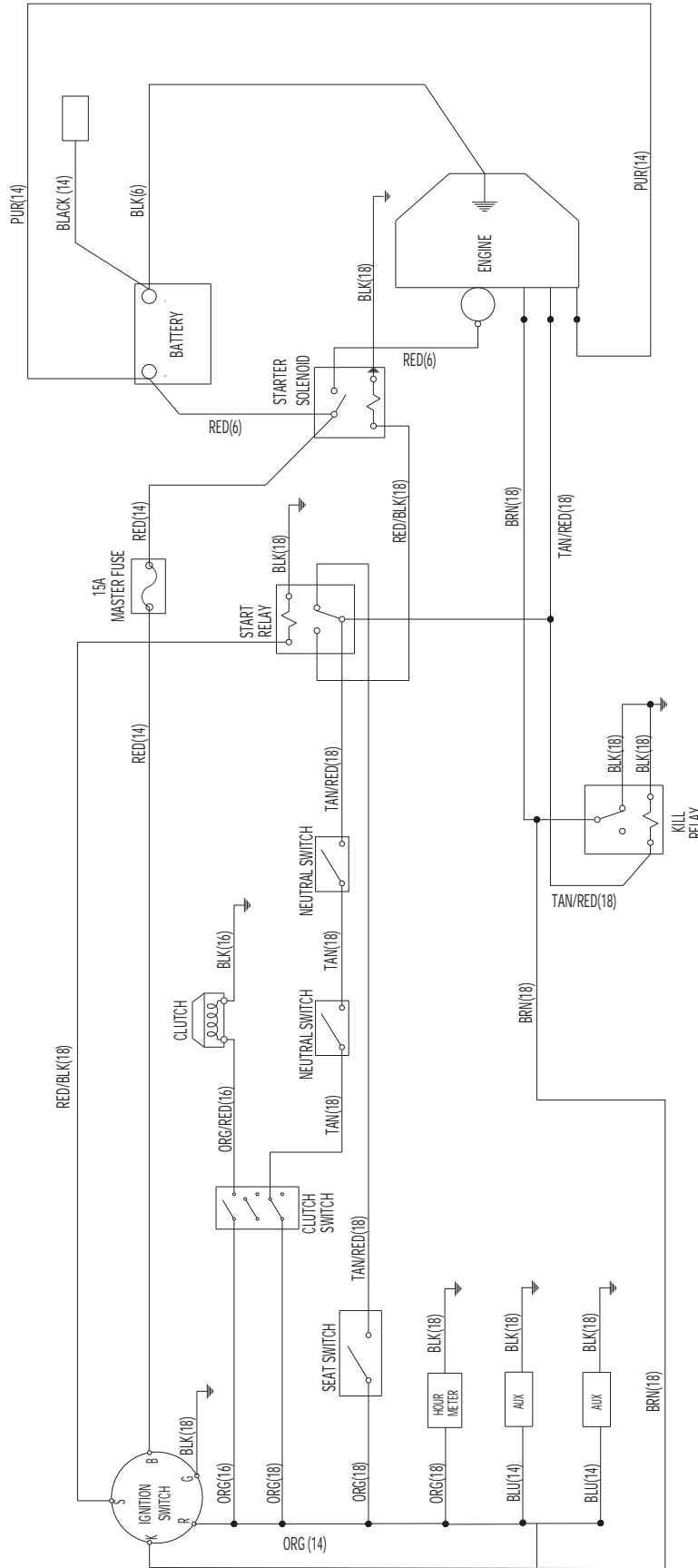

Figure 6-17

ELECTRICAL

Electrical Schematic — Kawasaki



MAINTENANCE

Maintenance Schedule Refer to Figure 8-1, Figure 8-2, Figure 8-3, Figure 8-4, & Figure 8-5		
SERVICE AT INTERVALS INDICATED	WEEKLY OR 40 HOURS	* ANNUALLY OR 100 HOURS
Verify safety start interlock system	Prior to each use	
Visually inspect unit for loose hardware and/or damaged parts	Prior to each use	
Visually inspect tires	Prior to each use	
Check oil level, engine (1)	Prior to each use or every 4 hours	
Clean air intake screen (7)	Prior to each use or every 4 hours	
Check fuel level	Prior to each use	
Blades - sharpen & securely fastened	Prior to each use	
Discharge chute - securely in place & in lowest position	Prior to each use	
Check tire pressure with a gauge	Prior to each use	
Clean engine and transmission compartment	After each use	
Replace engine air cleaner element (4) (8)	As needed	
Change engine oil & filter (1) (3)	X	
Clean cylinder and head fins (8)	X	
Check battery connections	X	
Clean engine exterior (8)	X	
Tighten drive wheel axle bolts (2)	X	
Clean & regap spark plugs (8)		X
Check transmission & deck belt tension and condition (5)		X
Check fuel system (6)		X
Check fuel tank grommet (6)		X
Change fuel filter (6)		X
Replace fuel evaporation system filter (7)		X
Replace spark plugs (8)		X

NOTES:

1. Initial engine oil change between 5 and 10 hours of operation. Thereafter, change oil after every 40 – 60 hours of operation or annually, whichever comes first. Change more often under dusty or dirty conditions and during hot weather periods. Hustler® Motor Oil is recommended.
2. Torque initially and after first 2 hours of operation.
3. Change engine oil filter per the engine manufacturer's recommendations. Refer to Engine Owner's Manual for recommendations and other maintenance items.
4. Service more often under dusty or dirty conditions. Use caution when servicing to prevent dust contamination in the engine. **Do not** clean filter element. Replace with a new one.
5. **Pump drive belt only - Inspect every month** and replace if worn or cracking is noticed. Otherwise, **replace every 2 years**.
6. Check fuel system for any cracks or leaks including, but not limited to, fuel line hoses, fuel valve, vent line hoses, vent valve, vapor valve, and grommets. Replace as needed.
7. More often under dusty or dirty conditions and during hot weather.
8. Refer to engine owner's manual for engine service information.

* After completing maintenance cycle (100 hours), repeat cycle.

Maintenance Locator Chart

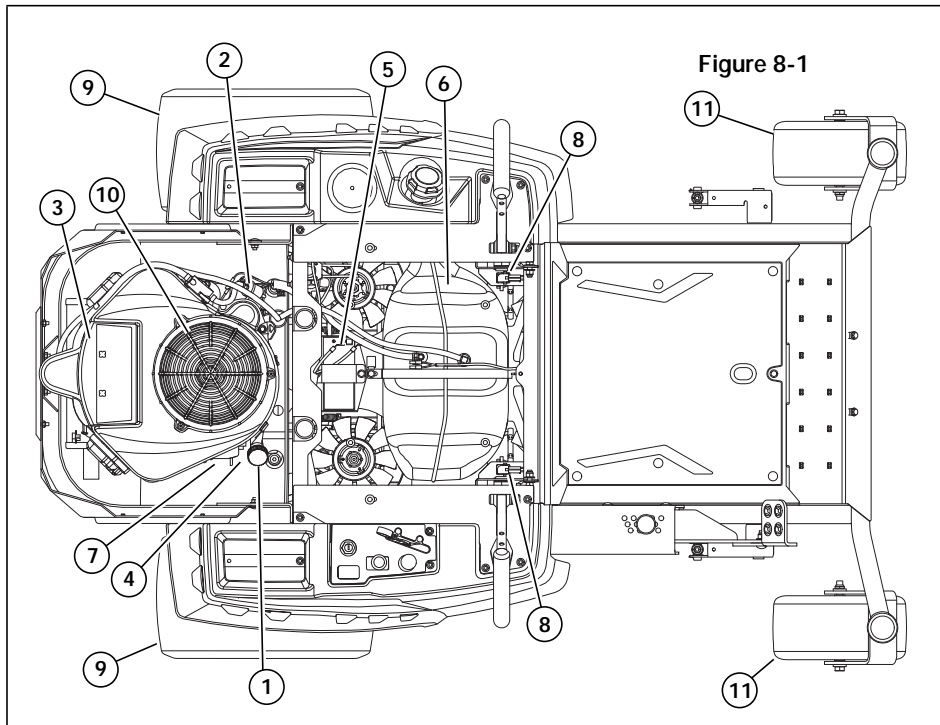

1. Engine Oil Fill & Dipstick
2. Fuel Filter
3. Engine Air Cleaner
4. Engine Oil Drain Valve
5. Battery
6. Fuel Tank
7. Engine Oil Filter
8. Park Brake Switch (2)
9. Drive Tire
10. Engine Air Intake Screen
11. Front Wheel Tires
12. Pump Belt
13. Deck Belt
14. Blades
15. Fuel Evaporation System Filter

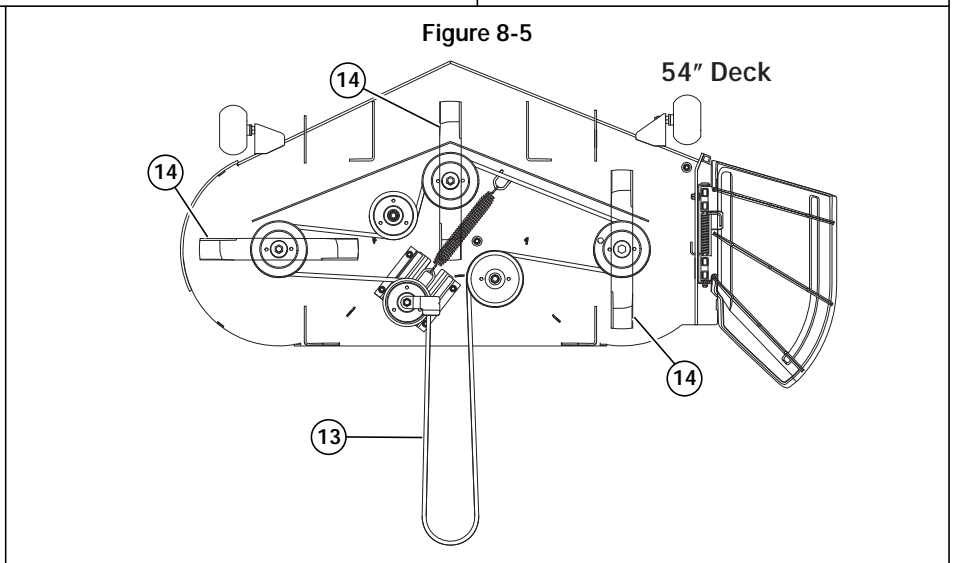
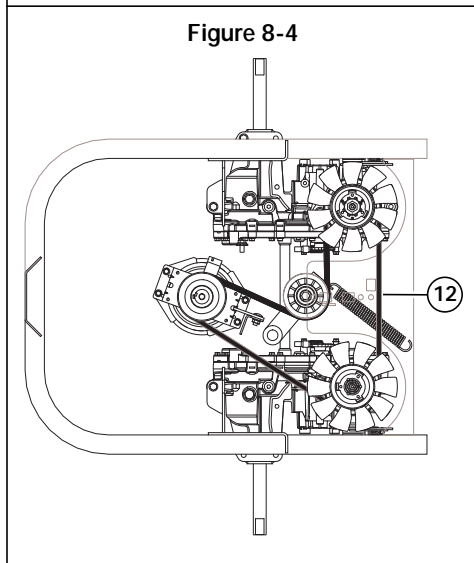
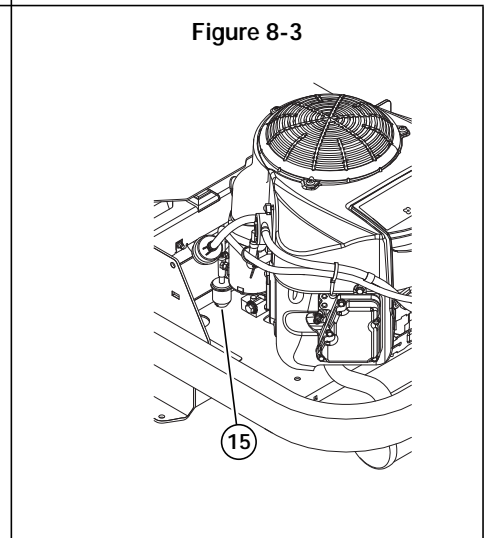
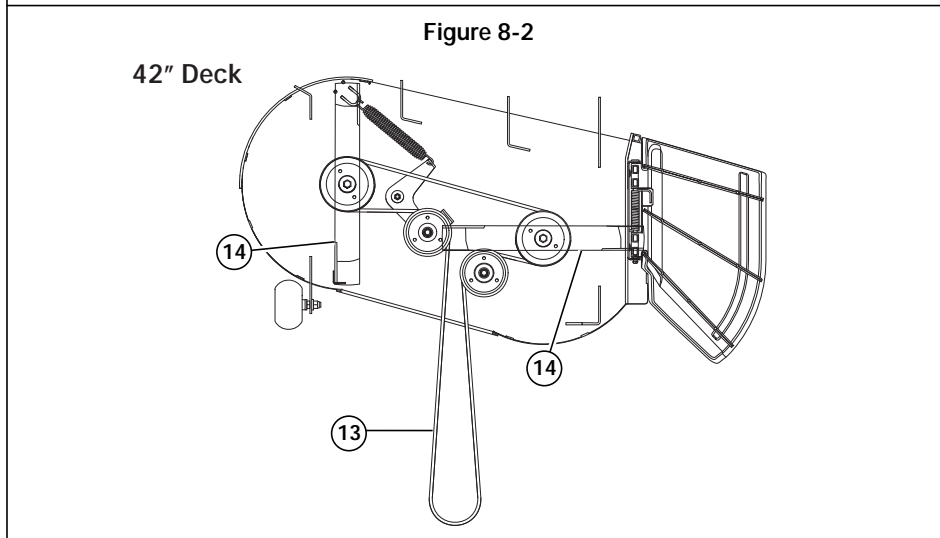

TROUBLESHOOTING

SYMPTOMS	PROBABLE CAUSES	SUGGESTED REMEDIES
Starting motor does not crank	Steering control levers not in park brake position or switch not adjusted	Place steering control levers in park brake position or re-adjust switch
	Deck clutch switch engaged	Disengage clutch switch
	Weak or dead battery	Recharge or replace
	Electrical connections are corroded or loose	Check the electrical connections
	15 amp fuse is blown	Replace the 15 amp fuse
	For additional causes	See engine manual
The engine will not start, starts hard or fails to keep running	No fuel or line plugged	Fill tank or replace line (See <i>Fuel System</i> section for more details)
	There is incorrect fuel in the fuel system	Drain the tank and replace the fuel with the proper type
	There is dirt in the fuel filter	Replace the fuel filter
	Dirt, water or stale fuel in the fuel system	Contact your Dealer
	The choke is not on (if equipped)	Move the choke lever to ON
	Numerous	See engine manual
Engine: Runs with continuous misfiring or engine runs unevenly or erratically	Numerous	See engine manual
Loss of power or system will not operate in either direction	Restrictions in air cleaner	Service air cleaner
	Poor compression	Contact your Dealer
	Steering linkage needs adjustment	Adjust linkage
	Tow valve open	Close tow valve
	The traction drive belt is worn, loose or broken	Install a new traction drive belt
	For additional causes	See engine manual
Air cooled engine overheating	Air intake screen or cooling fins clogged	Clean screen and fins
	For additional causes	See engine manual
Low engine oil pressure	Low oil level	Add oil
	Oil diluted or too light	Change oil and check for source of contamination
	Failed oil pump	Contact your Dealer
High oil consumption	Numerous	Contact your Dealer
Mower jerky when starting or operates in one direction only	Steering control linkage needs adjustment	Adjust linkage
	Loose steering linkage	Tighten linkage
	Transaxle component faulty	Contact your Dealer

SYMPTOMS	PROBABLE CAUSES	SUGGESTED REMEDIES
Mower creeps when steering control levers are in neutral	Steering linkage needs adjustment	Adjust linkage
Mower circles or veers in one direction	Steering linkage needs adjustment	Adjust linkage
	Loose steering linkage	Tighten linkage
	Tires improperly inflated	Adjust air pressure to 8–12 psi (55–83 KPa)
	Transaxle component faulty	Contact your Dealer
Mower creeps when parking brake engaged	Steering linkage out of adjustment	Adjust steering linkage
	Brake cable damaged	Replace brake cable
There is abnormal vibration	The engine mounting bolts are loose	Tighten the engine mounting bolts
	The engine pulley, idler pulley or blade pulley is loose	Tighten the appropriate pulley
	The engine pulley is damaged	Contact your Dealer
	The cutting blade(s) is/are bent or unbalanced	Install new cutting blade(s)
	A blade mounting bolt is loose	Tighten the blade mounting bolt
	Spindle bearing is worn or loose	Replace or tighten spindle bearing
	A blade spindle is bent	Contact your Dealer
Blades do not rotate	The deck drive belt is worn, loose or broken	Install a new deck drive belt
	The deck drive belt is off the pulley	Install the deck drive belt and check for a reason
	Electric clutch is not engaging	Check and/or replace 15 amp fuse. Contact your Dealer
Uneven cutting height	The blade(s) are not sharp	Sharpen the blades
	A cutting blade(s) is/are bent	Install new cutting blade(s)
	The deck is not level	Level the deck per the <i>Deck Levelling</i> section of the General Service Manual
	An anti-scalp wheel is not set correctly	Adjust the height of the anti-scalp wheel
	The underside of the deck is dirty	Clean the underside of the deck
	Tires improperly inflated	Adjust air pressure to 8–12 psi (55–83 KPa)
	A blade spindle is bent	Contact your Dealer
	Flex Forks [®] are installed	After initial break-in period, level the deck per the <i>Deck Levelling</i> section of the General Service Manual

INDEX

	PAGE		PAGE
Avoid Acid Burns	2-4	Maintenance Locator Chart	8-2
Avoid Fire Hazards	2-2, 2-3	Maintenance Precautions	2-3
Belt Adjustment	4-3	Mower Blade Maintenance	6-1
Belt Replacement	4-4	Mower Blade Replacement	6-3
Blades	6-1	Operate Machine Safely	2-2
Control Lever Stops Adjustment	4-2	Operation Precautions	2-2
Deck Belt	6-4	Park Brake Spring Adjustment	4-3
Deck Belt Adjustment	6-4	Pre-operation Precautions	2-1
Deck Belt Replacement	6-5	Prepare for Emergencies	2-3
Deck Belt Routing	6-7	Prevent Battery Explosions	2-3
Deck Leveling	6-1	Safe Servicing Practices	2-1
Electrical Schematic — Kawasaki	7-1	Service Program	1-1
Engine Air Filter	5-1	Special Torques	3-1
Engine Oil and Filter	5-1	Standard Torques	3-1
Engine RPM Settings	5-3	Start Engine Safely	2-2
Fuel & Evaporative System Line Routing	5-2	Steering Adjustments	4-1
Fuel Evaporation System Filter	5-2	Steering Control Lever Neutral Adjustment	4-1
General Engine Maintenance	5-1	Tires	4-7
General Maintenance Precautions	2-2	Transaxle Drive Belt	4-3
Hydraulic System	4-7	Warranty	1-1
Maintenance Introduction	1-1		

INDEX

PAGE

PAGE