

Hustler® FasTrak® SDX General Service Manual

***SMOOTHTRAK™
STEERING***



HUSTLER®
ENGINEERING PERFORMANCE™

200 South Ridge Road
Hesston, Kansas
67062

WARNING

The engine exhaust from this product contains chemicals known to the state of California to cause cancer, birth defects or other reproductive harm.

NOTICE OF REQUIREMENT OF SPARK ARRESTER MUFFLER

This equipment may create sparks that can start fires around dry vegetation. California Public Resources Code Section 4442.6 provides that it is unlawful to use or operate an internal combustion engine on any forest-covered, brush-covered, or grass-covered land unless the engine is equipped with a spark arrester maintained in effective working order. A spark arrester is a device constructed of nonflammable materials specifically for the purpose of removing and retaining carbon and other flammable particles over 0.0232 of an inch in size from the exhaust flow of an internal combustion engine that uses hydrocarbon fuels or which is qualified and rated by the United States Forest Service. Other states or federal areas may have similar laws. The Operator Should Contact Local Fire Agencies For Laws or Regulations Relating to Fire Prevention Requirements. THIS EQUIPMENT DOES NOT HAVE A SPARK ARRESTER AND YOU SHOULD CONTACT YOUR AUTHORIZED DEALER FOR THE PURCHASE OF A SPARK ARRESTER.

Inspect spark arrester daily; replace every 500 hours or as needed.

The Engine Owner's Manual provides information regarding the U.S. Environmental Protection Agency (EPA) and the California Emission Control Regulation of emission systems, maintenance and warranty.

Keep Engine Owner's Manual with your unit. Should the Engine Owner's Manual become damaged or illegible, replace immediately. Replacements may be ordered per the information found in the Product Information section of the owner's manual.

Federal law and California State law prohibit the following acts or the causing thereof:

- 1. The removal or rendering inoperative by any person other than for purposes of maintenance, repair, replacement, of any device or element of design incorporated into any equipment for the purposes of emissions control prior to or after its sales or delivery to the ultimate purchaser or while it is in use, or**
- 2. The use of the equipment after such device or element of design has been removed or rendered inoperative by any person.**

Table of Contents

General Information	1-1
Hustler® Service Program	1-1
Maintenance Introduction	1-1
Warranty	1-1
Safety	2-1
Safe Servicing Practices	2-1
Understand Correct Service	2-1
Pre-Operation Precautions	2-1
Operation Precautions	2-2
Operate Machine Safely	2-2
General Maintenance Precautions	2-2
Maintenance Precautions	2-3
Torque	3-1
Standard Torques	3-1
Special Torques	3-1
Power Unit Maintenance	4-1
Steering Adjustments	4-1
Park Brake Spring Adjustment	4-3
Steering Control Lever Stops	4-4
Belts	4-5
Hydraulic Pump Belt Adjustment	4-5
Hydraulic System	4-5
Tires	4-9
Engine Maintenance	5-1
General Engine Maintenance	5-1
Engine Oil and Filter	5-1
Engine Air Filter	5-2
Fuel Evaporation System Filter	5-4
Fuel & Evaporative System Line Routings	5-4
Engine RPM Settings	5-6
Deck Adjustments	6-1
Deck Leveling	6-1
Blades	6-2
Belts	6-4
Deck Belt Adjustment	6-4

Deck Belt Installation	6-4
Belt Routing and Tensioning	6-5
Side Discharge Deck Belt Routing.	6-5
Rear Discharge Deck Belt Routing	6-6
Electrical	7-1
Main Electrical Harness Schematic — Kawasaki	7-1
Main Electrical Harness Schematic — Kohler	7-2
Main Harness to Fuel Gauge Voltage Converter Schematic.	7-3
Maintenance	8-1
Maintenance Locator Chart	8-2
Troubleshooting	9-1

GENERAL INFORMATION

Hustler® Service Program

This manual is part of a service package for the Hustler® FasTrak® SDX mowers. Use of this manual in conjunction with other Hustler® mower and component manuals will provide the information necessary to service and maintain the Hustler® FasTrak® SDX mower.

This General Service Manual is a service guide for use by Service Technicians. It provides the necessary information needed to perform normal maintenance requirements on these units.

The Parts Manual provides a complete parts listing for the unit. Use this manual when ordering parts.

The Operator's Manual provides fundamental operational information and operational safety that is needed when operating the mower.

The component manuals are furnished by the various manufacturers to be used for the troubleshooting and servicing of their components.

Maintenance Introduction

Regular maintenance is the best prevention for downtime or premature failure. The following pages contain suggested maintenance information and schedules which the operator/mechanic should follow on a routine basis.

Remain alert for unusual noises, they could be signaling a problem. Visually inspect the machine for any abnormal wear or damage. A good time to detect potential problems is while performing scheduled maintenance service. Correcting the problem as quickly as possible is the best insurance.

Clear away heavy build-up of grease, oil and dirt, especially in the engine compartment and under the seat platform areas; minute dust particles are abrasive to close-tolerance engine and hydraulic assemblies.

Daily inspect mower for grass clippings and wire and string tangles. The underside of the mower deck will collect a build-up of grass clippings and dirt, especially when grass is wet or has high moisture content. This build-up will harden, restricting blade and air movement and will probably show a lesser quality of cut. Therefore it should be removed routinely.

To do this it will be necessary to raise and block the deck, using jack stands or blocks, in the full up position and scrape the build-up from underneath.

Some repairs require the assistance of a trained service mechanic and should not be attempted by unskilled personnel. Consult your Hustler® Turf Equipment service center when assistance is needed.

Information included in this manual was current at the time of printing, but subsequent production changes may cause your machine to vary slightly in detail. Hustler® Turf Equipment reserves the right to redesign and change the machine as deemed necessary, without notification. If a change has been made to your machine which is not reflected in this service manual contact the Customer Service Department at Hustler® Turf Equipment for additional information.

Warranty

Warranty repair must be performed by a Hustler® Turf Equipment Authorized Dealer before warranty credit can be allowed.

SAFETY



This safety alert symbol is used to call attention to a message intended to provide a reasonable degree of PERSONAL SAFETY for operators and other persons during the normal operation and servicing of this equipment.

⚠ DANGER

– denotes immediate hazards which **WILL** result in severe personal injury or death.

⚠ WARNING

– denotes a hazard or unsafe practice which **COULD** result in severe personal injury or death.

Safe Servicing Practices

Refer to the *Safety Precautions* section of this manual for more service safety information.

Understand Correct Service

- ▲ Be sure you understand a service procedure before you work on the machine.
- ▲ Unauthorized modifications to the machine may impair the function and/or safety and affect machine life.
- ▲ If it is necessary to make checks with the engine running, always use two people - with the operator at the controls, able to see the person doing the checking.

Pre-Operation Precautions

Fuel Handling

- ▲ To avoid personal injury or property damage, use **extreme care when handling gasoline. Gasoline is extremely flammable and the vapors are explosive.**
 - A fire or explosion from gasoline can burn you and others and can damage property.
- ▲ Observe the usual gasoline handling precautions:

- Do not smoke while refueling. Extinguish all cigarettes, cigars, pipes and other sources of ignition.
- **Do not remove fuel cap or fill tank with engine running or while engine is hot.** Clean up any gasoline spills.
- If gasoline is spilled, do not attempt to start the engine but move the machine away from the area of spillage and avoid creating any source of ignition until gasoline vapors have dissipated.
- Keep gasoline away from open flame or spark and store machine away from open flame or spark or pilot light such as on a water heater or appliances.
- Refuel outdoors. Never refuel or drain the gasoline from the machine indoors.
- Never attempt to start the engine when there is a strong odor of gasoline fumes present. Locate and correct the cause.
- Store gasoline in an approved container and keep it out of the reach of children. Never buy more than a 30-day supply of gasoline.
- Do not fill fuel containers inside a vehicle or on a truck or trailer bed with interior carpets or plastic truck bed liners. Always place gasoline containers on the ground away from your vehicle before filling.
- When practical, remove the machine from the truck or trailer and refuel the machine with its wheels on the ground. If this is not possible, then refuel such machine on the truck or trailer using a portable container and not a fuel dispenser nozzle. If a fuel dispenser nozzle must be used, keep the nozzle in contact with the rim of the fuel tank or container opening at all times until fueling is complete. Do not use a nozzle lock-open device.
- Never use gasoline for cleaning parts.
- Read and observe safety precautions elsewhere in this manual.
- ▲ Gasoline is harmful or fatal if swallowed.
- ▲ Avoid prolonged breathing of vapors.
 - Long-term exposure to vapors can cause serious injury and illness.
- ▲ Keep gasoline away from eyes and skin.
 - Keep face away from nozzle and fuel tank or fuel container opening.
 - If gasoline is spilled on clothing, change clothing immediately.

Understand Machine Operation

- ▲ Only qualified and trained personnel should operate the equipment.
- ▲ Carefully read the operator's manual and all manuals furnished with the attachments. Learn the location and purpose of all controls, instruments, indicators and labels.

Wear Protective Clothing

- ▲ Do not operate or service the equipment while wearing sandals, tennis shoes, sneakers, shorts or any type of loose fitting clothing. Long hair, loose clothing or jewelry may get tangled in moving parts. Always wear long pants, safety glasses, ear protection and safety shoes when operating or servicing this machine.
- ▲ Always wear adequate eye protection when servicing the hydraulic system and battery, or when grinding mower blades and removing accumulated debris.
- ▲ Prolonged exposure to loud noise can cause impairment or loss of hearing.
 - Always wear adequate ear protection, such as earplugs, when operating this equipment as prolonged exposure to uncomfortable or loud noises can cause impairment or loss of hearing.
 - Do not wear radios or music headphones while operating the machinery. Safe operation requires your full attention.

Operation Precautions

Avoid Fire Hazards

- ▲ **Clean flammable material from machine. Prevent fires by keeping engine compartment, top of deck, exhaust area, battery, hydraulic lines, fuel line, fuel tank and operator's station clean of accumulated trash, grass clippings, and other debris. Always clean up spilled fuel and oil.**

Start Engine Safely

- ▲ Avoid possible injury or death from machine runaway.
- ▲ Do not start engine by shorting across starter terminals.
- ▲ Before you start the engine:
 - Sit on the operator's seat.
 - Move control levers to the neutral/brake position.

Operate Machine Safely

- ▲ Refer to the unit's operator's manual for complete safety information on safe machine operation.
- ▲ Always maintain a safe distance from people and pets when mowing
- ▲ Always be aware of what is behind the machine before backing up.

- ▲ Never leave machine unattended with ignition key in switch, especially with children present.
- ▲ Follow daily and weekly checklists, making sure hoses are tightly secured and bolts are tightened.
- ▲ Always keep engine and machine clean, removing accumulated dirt, trash and other material from machine.
- ▲ Never put hands or feet under any part of the machine while it is running.
- ▲ Never attempt to start engine when there is a strong odor of gasoline fumes present. Locate and correct cause.
- ▲ Keep all safety shields and covers in place, except for servicing.
- ▲ Do not touch hot parts of machine.

General Maintenance Precautions

- ▲ **Repairs or maintenance requiring engine power should be performed by trained maintenance personnel only.**
- ▲ Never run the engine in an enclosed area unless exhaust is vented to the outside. Exhaust gases contain carbon monoxide which is an odorless and deadly poison.
- ▲ Unless specifically required, **DO NOT** have the engine running when servicing or making adjustments to the mower.
 - Park the mower on level ground
 - Disengage the deck clutch.
 - Place the steering control levers in the park brake position.
 - Lower the deck.
 - Stop the engine.
 - Remove the ignition key.
 - Disconnect the negative battery cable.
 - Wait for all movement to stop before adjusting, cleaning or repairing.
 - Repairs or maintenance requiring engine power should be performed by trained maintenance personnel only.
 - To prevent carbon monoxide poisoning, operate the engine in a well ventilated area only.
 - Read and observe all safety warnings in this manual.
- ▲ Before working on or under the deck, make certain engine cannot be accidentally started. Shut engine off, remove ignition switch key and disconnect negative battery cable for maximum safety.
- ▲ Except when changing or checking belt, **always** keep belt covers on mower deck for safety as well as cleanliness.

- ▲ Use a stick or similar instrument to clean under the mower making sure that no part of the body, especially arms and hands are under mower.
- ▲ Keep your machine clean and remove any deposits of trash and clippings, which can cause engine fires and hydraulic overheating as well as excessive belt wear. Clean up oil or fuel spillage. Allow machine to cool before storing.
- ▲ Always wear adequate eye protection when servicing the hydraulic system and battery, or when grinding mower blades and removing accumulated debris.
- ▲ Never attempt to make any adjustments or repairs to the mower drive system, mower deck or any attachment while the engine is running or deck clutch is engaged.
- ▲ Exercise caution when releasing spring tension from any of the belt idlers or when working with any of the deck lift components.
- ▲ Never work under the machine or attachment unless it is safely supported with jack stands. Make certain machine is secure when it is raised and placed on the jack stands. The jack stands should not allow the machine to move when the engine is running and the drive wheels are rotating. **Use only certified jack stands.** Use only appropriate jack stands, with a minimum weight rating of 2000 pounds to block the unit up. Use in pairs only. Follow the instructions supplied with the vehicle stands.
- ▲ Keep nuts and bolts tight, especially the blade attachment bolts. Keep equipment in good working condition.
- ▲ Never tamper with safety devices. Check their proper operation regularly.
- ▲ Exercise caution when working under the deck as the mower blades are extremely sharp. Wrap the blade(s) or wear gloves and use extra caution when servicing them.
- ▲ Use original Hustler® replacement parts or parts that are equivalent in overall performance.
 - The mower may not comply with the appropriate safety standards if aftermarket parts, accessories, or attachments are used.

Maintenance Precautions

Avoid Fire Hazards

- ▲ Be prepared if an accident or fire should occur. Know where the first aid kit and the fire extinguishers are located and how to use them.
- ▲ Provide adequate ventilation when charging batteries.
- ▲ Do not smoke near battery.
- ▲ Never check fuel level with an open flame.
- ▲ Never use an open flame to look for leaks anywhere on the equipment.

- ▲ Never use an open flame as light anywhere on or around the equipment.
- ▲ When preparing engine for storage, remember that fuel stabilizer is volatile and therefore dangerous. Seal and tape openings after adding the inhibitor. Keep container tightly closed when not in use.
- ▲ Inspect electrical wiring for worn or frayed insulation. Install new wiring if wires are damaged.

Prepare for Emergencies

- ▲ Be prepared if a fire starts.
- ▲ Keep a first aid kit and fire extinguishers available.
- ▲ Keep emergency numbers for doctor, ambulance service, hospital, and fire department near the telephone.

Prevent Battery Explosions

- ▲ Battery posts, terminals, and related accessories contain lead and lead compounds, chemicals known to the State of California to cause cancer and reproductive harm. Wash hands after handling.
- ▲ Charge batteries in a well-ventilated open area, away from sparks and flames. Unplug charger before connecting or disconnecting from battery. Wear protective clothing and use insulated tools.
- ▲ Avoid skin and clothing contact with battery acid.
 - Always wear eye protection when checking the battery. Acid can cause serious injury to skin and eyes. If contact occurs, flush area with clean water and call a physician immediately. Acid will also damage clothing.
 - Do not drink the battery electrolyte.
 - Do not allow open flame near the battery when charging.
 - Hydrogen gas forms inside the battery. This gas is both toxic and flammable and may cause an explosion if exposed to flame. Always **disconnect** the negative (black) battery cable(s) before disconnecting the positive (red) cable(s). Always **connect** the positive (red) battery cable(s) before connecting the negative (black) cable(s).
 - Do not overfill the battery.
 - Electrolyte may overflow and damage paint, wiring or structure. When cleaning the battery, use soap and water. Be careful not to get soap and water into the battery. Clean the battery terminals with a solution of four parts water and one part baking soda when they become corroded.
- ▲ Shorts caused by battery terminals or metal tools touching metal mower components can cause sparks. Sparks can cause a battery gas explosion which will result in personal injury.

- Prevent the battery terminals from touching any metal mower parts when removing or installing the battery.
- Do not allow metal tools to short between the battery terminals and metal mower parts.
- ▲ Incorrect battery cable routing could cause damage to the mower and battery cables. This can cause sparks which can cause a battery gas explosion which will result in personal injury.
 - Always **disconnect** the negative (black) battery cable(s) before disconnecting the positive (red) cable(s).
 - Always **connect** the positive (red) battery cable(s) before connecting the negative (black) cable(s).

Avoid Acid Burns

- ▲ Sulfuric acid in battery electrolyte is poisonous. It is strong enough to burn skin, eat holes in clothing and cause blindness if splashed in eyes.

Avoid the hazard by:

- Filling batteries in a well-ventilated area.
- Wearing eye protection and rubber gloves.
- Avoiding breathing fumes when electrolyte is added.
- Avoiding spilling or contacting dripped electrolyte.

If you spill acid on yourself:

- Flush your skin with water.
- Apply baking soda or lime to help neutralize the acid.
- Flush your eyes with water for 10–15 minutes. Get medical attention immediately.

If acid is swallowed:

- Drink large amounts of water or milk.
- Then drink milk of magnesia, beaten eggs or vegetable oil.
- Get medical attention immediately.

TORQUE

Standard Torques

The following chart lists the standard torque values for the threaded fasteners found in this manual. Torque all cap screws, nuts and set screws to these values unless a different torque is shown in the *Special Torques* section.

Size	ft-lbs	N•m	Size	ft-lbs	N•m
#10	32.4 IN.-LBS.	3.6	M3	12 IN.-LBS.	1.3
.250	98.4 IN.-LBS.	11.1	M4	26.4 IN.-LBS.	3
.312	204 IN.-LBS.	23	M5	54 IN.-LBS.	6.1
.375	30	40	M6	92.4 IN.-LBS.	10.4
.438	48	65	M8	222 IN.-LBS.	25
.500	73	99	M10	37	50
.562	105	143	M12	64	87
.625	145	200	M14	103	140
.750	260	350	M16	160	215
.875	420	565	M20	320	435

Special Torques

Size	ft-lbs	N•m
Wheel (lug) nuts ¹	70	95
Blade spindle bolt top	70	95
Blade spindle bolt bottom	118	160
Electric Clutch mounting bolt ³	45–48	61–65
Front wheel axle bolt	Tighten the nut, then back it off until the wheel spins freely	
Transaxle hub nut	275	339
Transaxle pump pulley nut	45–55	61–74.6

NOTE:

- Lug nuts only** – It is recommended that these be checked after the first 2 hours of operation and every 40 hours and following removal for repair or replacement.
- Engine torque values** – Refer to the respective engine owner's manual.
- If clutch mounting bolt is loosened or removed, **do not re-use**. Replace with a new bolt. Use only hand tools to install this fastener.



Particular attention must be given to tightening the drive wheel lug nuts and blade spindle bolts. Failure to correctly torque these items may result in the loss of a wheel or blade, which can cause serious damage or personal injury.

POWER UNIT MAINTENANCE

Steering Adjustments

Steering Control Lever Neutral Adjustment

The mower's steering has been factory adjusted to eliminate creeping when the steering control levers are in the neutral position. However, should the mower begin to creep, the steering control lever linkage can be adjusted.

Before considering any adjustment, check the tire air pressure. Unequal tire pressure will cause the mower to drift to one side. Refer to the tire pressure information in the *Tires* section for detailed information.

NOTE: Proper park brake adjustment must be completed before the steering control lever neutral adjustment can be done. Refer to the *Park Brake Spring Adjustment* section for detailed information.

Fine adjustment to the unit's steering is made with the transmission's control rod.

Neutral is properly adjusted when the steering control levers are in the park brake position and the transmissions do not "whine".

If this occurs, the steering control linkage may be adjusted as follows:

WARNING

This procedure will require that the unit be raised to allow the drive wheel to rotate.

- Block the mower up off of the ground using only appropriate vehicle stands (minimum weight rating of 2000 pound)s. Use in pairs only. Follow the instructions supplied with the vehicle stands.
- Do not allow the wheels to come in contact with the floor or any object that would permit the unit to popel itself.
- To prevent injury stay clear and exercise caution when rotating the wheels.

WARNING

Exercise extreme caution when the transmissions are engaged.

- Keep hands, hair, clothing, etc., clear of the cooling fans on top of the transaxles to prevent entanglement.

WARNING

Untrained maintenance personnel should never attempt to make any adjustments or repairs to the mower's drive system while the engine is running. **The following procedures should be performed by trained maintenance personnel only.**

1. Raise the rear of the mower and block with certified jack stands. The rear wheels need to be able to rotate freely and clear of all obstructions.
2. Chock the front tires.
3. Unbolt or unlatch the seat platform from the mower frame. If the seat platform has a latch, unlatch it and pivot it forward to allow access to the seat switch on the underneath side of the seat.
 - Disconnect the mower harness from the seat switch.
 - Bypass the seat switch by connecting the two mower harness female spade connectors together. Figure 4-1
 - Secure the seat platform to the mower frame.

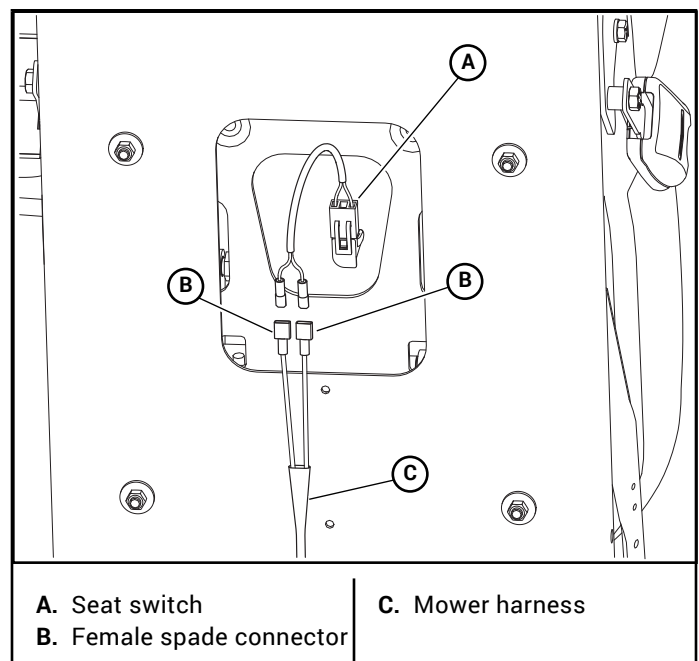

Figure 4-1

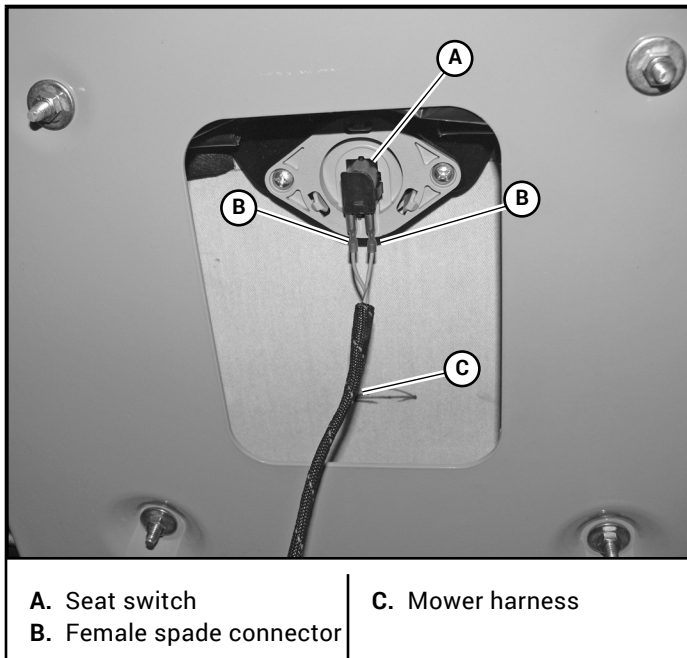

Figure 4-1

4. Loosen the jam nuts on each end of the steering control rod assemblies. Figure 4-4
5. Set both steering control levers in the park brake position. Figure 4-2

NOTE: Both steering control levers need to be in the park brake position when starting the engine but need to be moved rapidly out of the park brake position once engine is started so that the brakes do not fight the transmissions since they have not yet been adjusted.

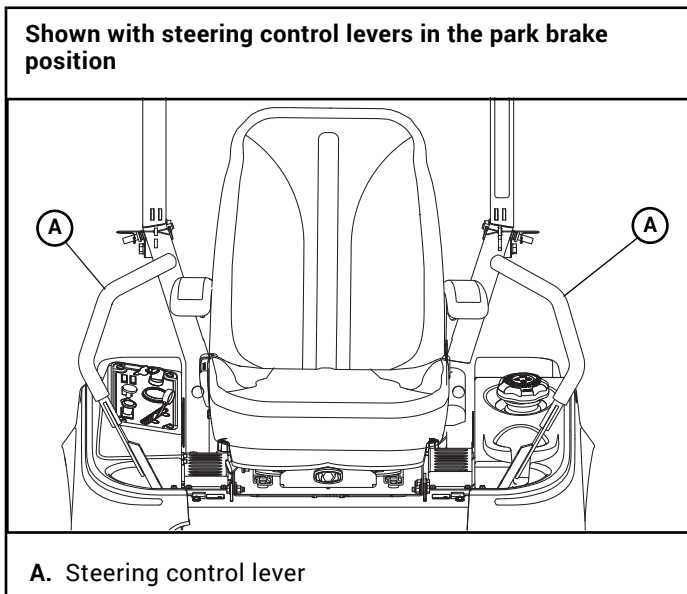

Figure 4-2

6. Start the engine. Move the steering control lever to barely engage the brake (neutral) slot and hold it in that position (do not engage the steering control lever far enough to engage the brakes in the brake slot).



This operation is extremely dangerous. Pay close attention when adjusting the steering control rod so you do not get your fingers, tools, or anything else close to the transaxle's cooling fans.

7. Beginning with the right side of the mower:
 - Adjust the steering control rod so that the right side wheel starts rotating forward while holding the steering control lever in the neutral position.
 - Adjust the steering rod back the opposite direction to the point when the wheel stops rotating.
 - From that point, turn the steering rod back again ½ turn. This ensures that the steering rod is adjusted so that the transmission control arm is centered in the neutral band of the transmission. Figure 4-5
 - Move the steering control lever forward and backward making sure that the wheel rotates forward and backward correctly.
 - Return the steering control lever to neutral and re-check to make sure the wheel has stopped in the neutral position.
 - Place the steering control lever in the park brake position. If neutral is set properly, you should not hear the transmission whine.

Shown with steering control levers in the neutral position

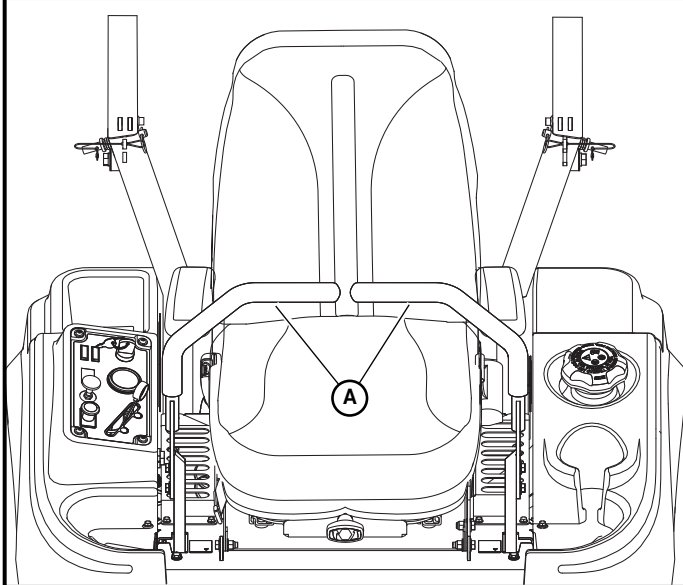

A. Steering control lever

Figure 4-3

8. Repeat steps 4 through 10 for the left side.
9. Once both sides are properly adjusted, check them together to make sure everything is working properly.

Shown with steering control lever in the neutral position

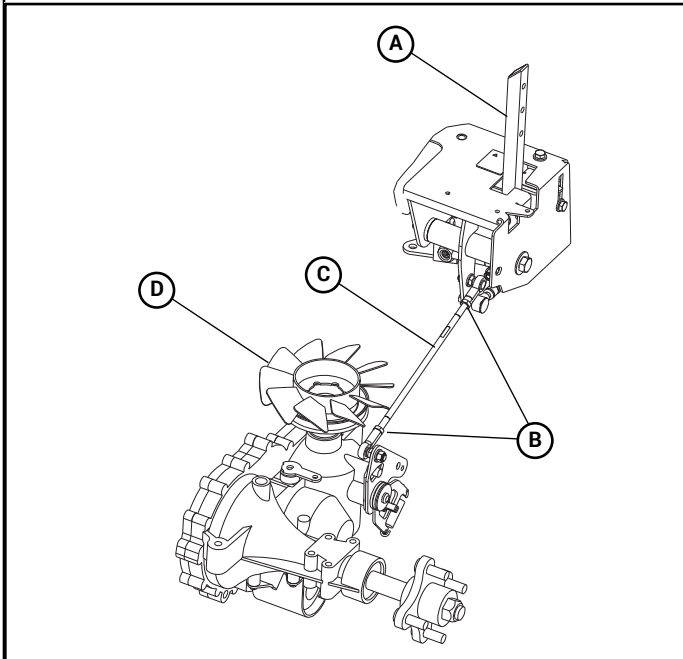

A. Steering control lever
B. Jam nuts

C. Steering control rod
D. Transaxle cooling fan

Figure 4-4

10. **IMPORTANT:** Unbolt or unlatch the seat platform from the mower frame.

- Disconnect the two female spade connectors from each other (from step #3).
- Reconnect the two female spade connectors to the seat switch. This must be completed so that the safety circuit is functioning properly. Figure 4-1
- Re-attach the seat platform to the mower frame.

WARNING Do not operate the mower without plugging the mower's wiring harness into the seat switch. This switch is an important part of the safety start interlock system. Serious injury can result if the seat switch is not plugged into the mower's wiring harness.

WARNING Never operate the mower with a non-functioning seat switch. Always reconnect the seat switch to the mower harness.

11. The steering control levers should be adjusted so that they align within $\pm .125"$ ($\pm 3.2\text{mm}$) of each other when in the neutral position. Figure 4-5

NOTE: The space between the ends of steering control handles should be $.50" \pm .25"$ ($12.2\text{mm} \pm 6.35\text{mm}$). Figure 4-5

12. Check to make sure all tools or obstructions are removed from under the mower.
13. Raise the rear of the mower and remove the jack stands. Lower the mower.
14. Remove the chocks from the front wheels.

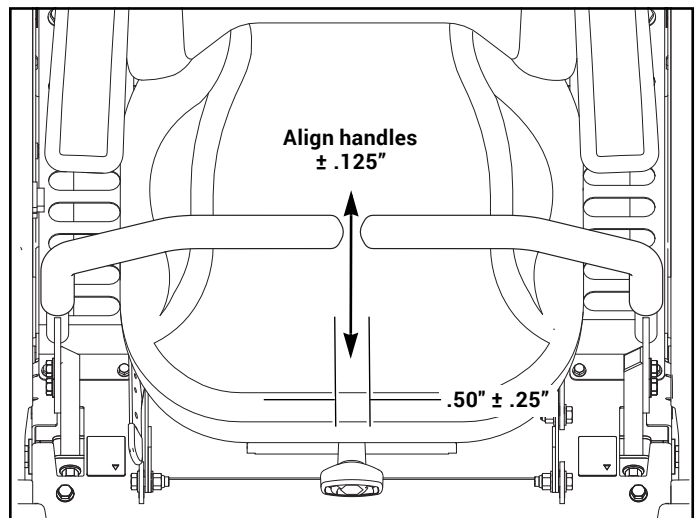

Figure 4-5

WARNING

Never operate the mower with the seat platform improperly secured. The seat platform must be securely latched/bolted to prevent the seat from moving/tilting in the event of mower tipping or roll-over.

Park Brake Spring Adjustment

Occasionally check the park brake spring adjustment using the following method:

1. This procedure does not require engine power, therefore:
 - Park the mower on level ground
 - Disengage the deck clutch.
 - Place the steering control levers in the park brake position.
 - Stop the engine.
 - Remove the ignition key.
 - Disconnect the negative battery cable.
2. On one side measure the park brake spring. It should be compressed to 1.43"–1.48" (36.3–37.6mm). If it is not, adjust the nylock nut until the proper spring compression is achieved. Figure 4-6
3. Repeat for other side.
4. Reconnect the negative battery cable.

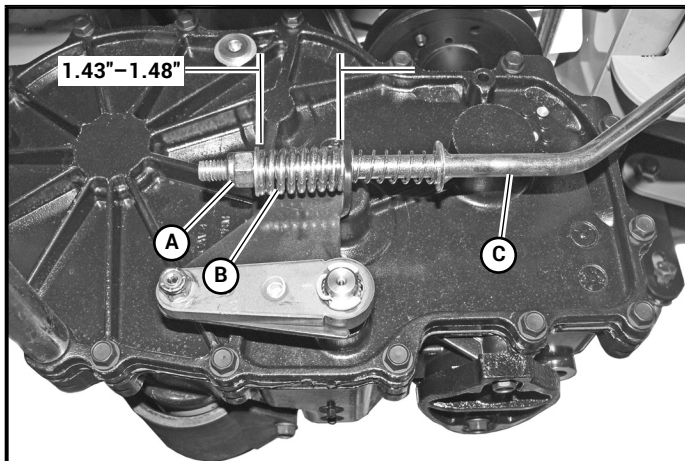

A. Nylock nut	C. Park brake rod
B. Park brake spring	

Figure 4-6

Steering Control Lever Stops

WARNING

This procedure will require that the unit to be raised to allow the drive wheel to rotate.

- Block the mower up off of the ground using only appropriate vehicle stands (minimum weight rating of 2000 pounds). Use in pairs only. Follow the instructions supplied with the vehicle stands.
- Do not allow the wheels to come in contact with the floor or any object that would permit the unit to propel itself.
- To prevent injury stay clear and exercise caution when rotating the wheels.

WARNING

Exercise extreme caution when the transmissions are engaged.

- Keep hands, hair, clothing, etc., clear of the cooling fans on top of the transaxles to prevent entanglement.

WARNING

Untrained maintenance personnel should never attempt to make any adjustments or repairs to the mower's drive system while the engine is running. **The following procedures should be performed by trained maintenance personnel only.**

IMPORTANT: Make sure the hydraulic system oil is at operating temperature before beginning this procedure.

1. Raise the rear of the mower and block with certified jack stands. The rear wheels need to be able to rotate freely and clear of all obstructions.
2. Chock the front tires.
3. Unbolt or unlatch the seat platform from the mower frame. If the seat platform has a latch, unlatch it and pivot it forward to allow access to the seat switch on the underneath side of the seat.
 - Disconnect the mower harness from the seat switch.
 - Bypass the seat switch by connecting the two mower harness female spade connectors together. Figure 4-7
 - Secure the seat platform to the mower frame.

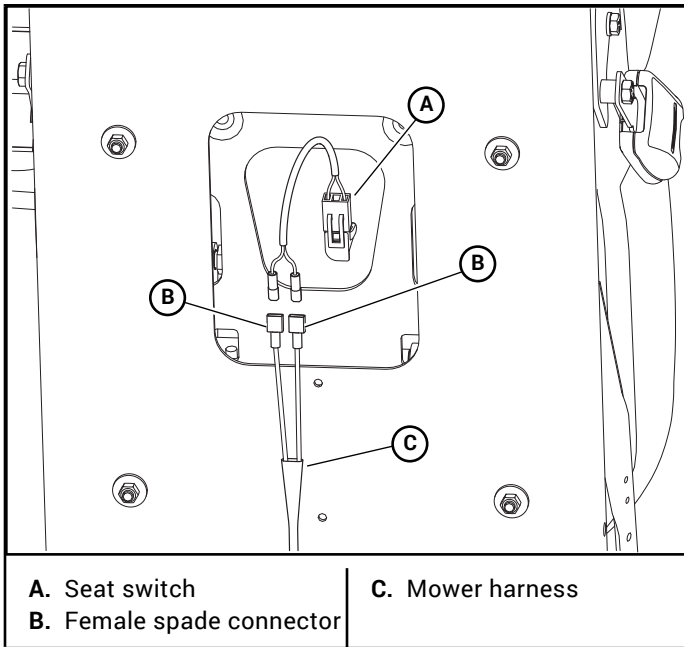

Figure 4-8

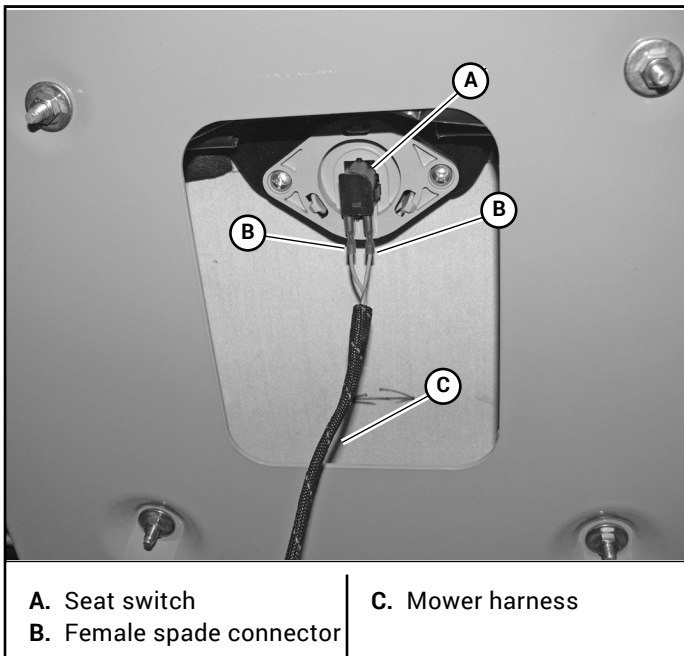

Figure 4-7

4. Start the engine. Move both steering control levers forward against the stops located inside the steering covers.
5. Determine if the drive wheels are rotating equally. If so, proceed to Step 8.
If one is rotating faster than the other proceed to the next step.
6. Return the steering control levers to the park brake position and shut the engine off.

7. Loosen the side cap screw on the outside of the steering cover on the side that is rotating too fast. Tighten the top cap screw to adjust the drive-straight bracket up. This allows the steering control lever to make contact with the drive-straight bracket sooner. Repeat until both drive wheels are rotating at the same speed. Figure 4-9
8. Tighten the side cap screws on both the left and right sides to lock the drive-straight brackets in place. Snug the top cap screws to prevent loosening during operation. Figure 4-9

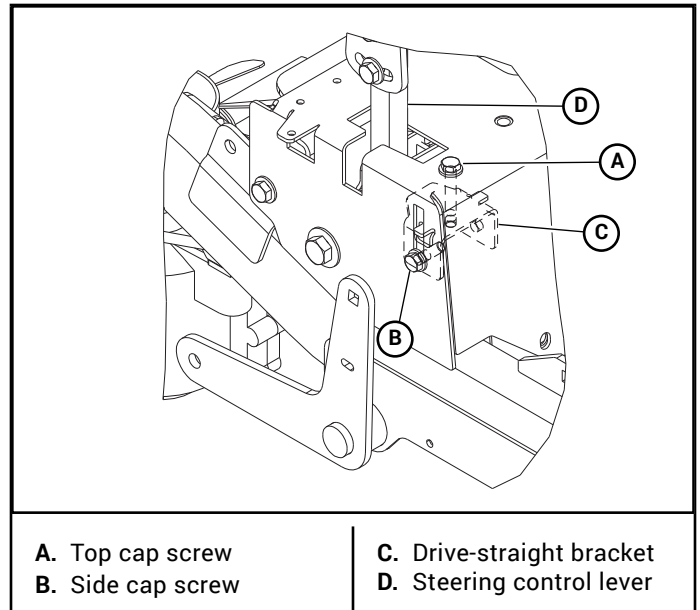

Figure 4-9

9. **IMPORTANT:** Unbolt or unlatch the seat platform from the mower frame. If the seat platform has a latch, unlatch it and pivot it forward to allow access to the seat switch on the underneath side of the seat.
 - Disconnect the two female spade connectors from each other (from step #3).
 - Reconnect the two female spade connectors to the seat switch. This must be completed so that the safety circuit is functioning properly. Figure 4-7
 - Secure the seat platform to the mower frame.



Do not operate the mower without plugging the mower's wiring harness into the seat switch. This switch is an important part of the safety start interlock system. Serious injury can result if the seat switch is not plugged into the mower's wiring harness.

WARNING

Never operate the mower with a non-functioning seat switch. Always reconnect the seat switch to the mower harness.

WARNING

Never operate the mower with the seat platform improperly secured. The seat platform must be securely latched/bolted to prevent the seat from moving/tilting in the event of mower tipping or roll-over.

Belts

Inspect belts frequently for wear and serviceability. Replace a belt that shows signs of:

- severe cuts
- tears
- separation
- weather checking
- cracking
- burns caused by slipping.

Slight raveling of belt covering does not indicate failure, trim ravelings with a sharp knife.

Inspect the belt pulley grooves and flanges for wear. A new belt, or one in good condition, should never run against the bottom of the groove. Replace the pulley when this is the case, otherwise, the belt will lose power and slip excessively.

Never pry a belt to get it on a pulley as this will cut or damage the fibers of the belt covering.

Keep oil and grease away from belts, and never use belt dressings. Any of these will destroy the belt composition in a very short time.

Hydraulic Pump Belt Adjustment

The transmission drive belt tension remains constant by means of a tension idler and spring. There is no tension adjustment of this belt. Figure 4-10

IMPORTANT: Inspect the belt every 100 hours and replace as needed. Replace the belt every 200 hours or every two (2) years whichever comes first.

WARNING

If the transmission belt fails, loss of control will occur especially when operating on a slope. If you lose steering control while operating the machine, place the steering control levers in the park brake position immediately. Inspect the machine and involve your dealer to resolve the problem.

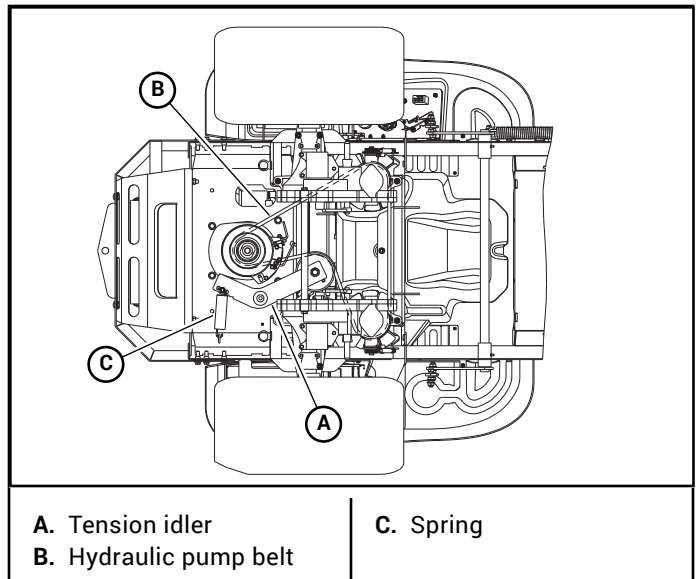
**Figure 4-10****Hydraulic System**

This mower is equipped with two integrated hydrostatic transmissions (transaxles). Figure 4-11

IMPORTANT: Never use hydraulic or automatic transmission fluid in this system; use only the specified motor oil. Remember, dirt is the primary enemy of any hydraulic system.

Each transaxle has its own hydraulic expansion tank. The tanks are located in front of the engine and behind the operator's platform. Figure 4-11

Check the oil level in the hydraulic system after every 50 hours of operation or weekly, whichever occurs first. Check more often if the system appears to be leaking or otherwise malfunctioning.

The mower ships from the factory with SAE 20W50 motor oil in the system. Use **SAE 20W50 motor oil, 15W50 synthetic oil, or 20W50 synthetic oil** when changing the system oil and filter. **Hustler® Full Synthetic 20W50 Hydrostatic Transmission Oil is recommended.**

When the hydraulic system oil is cold, the fluid level should be at the "Full Cold" line on the expansion tank.

Initial system oil and filter change **must** be after the **first 75 hours of use or 1 year whichever comes first**. Thereafter, replace filter and oil in each transaxle every 2 years or 200 hours, whichever comes first.

Each transaxle's filter is located per Figure 4-12. A standard oil filter wrench is used to change filter. The threads are right handed. **Use a Hustler® approved filter element only.**

NOTE: The filter guard must be removed to access the filter. Figure 4-12

IMPORTANT: When washing the mower, direct the spray away (especially if using a power washer) from the transaxle's seals to prevent water intrusion and to ensure component performance.

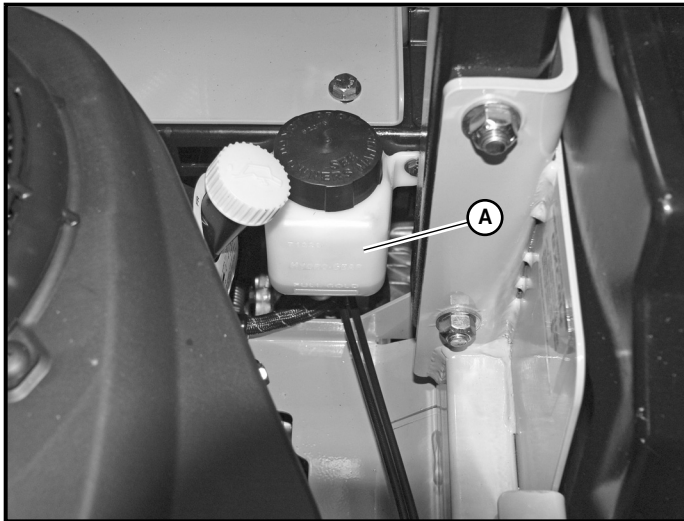

A. Expansion tank

Figure 4-11

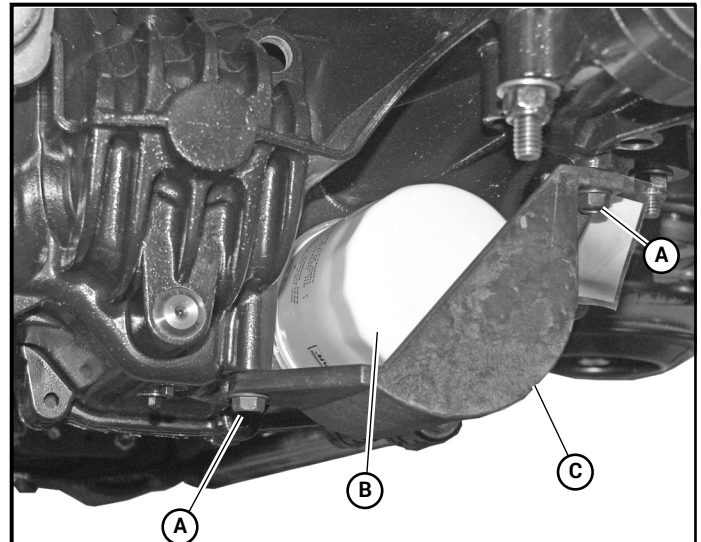

A. Screw
B. Filter

C. Filter guard

Figure 4-13

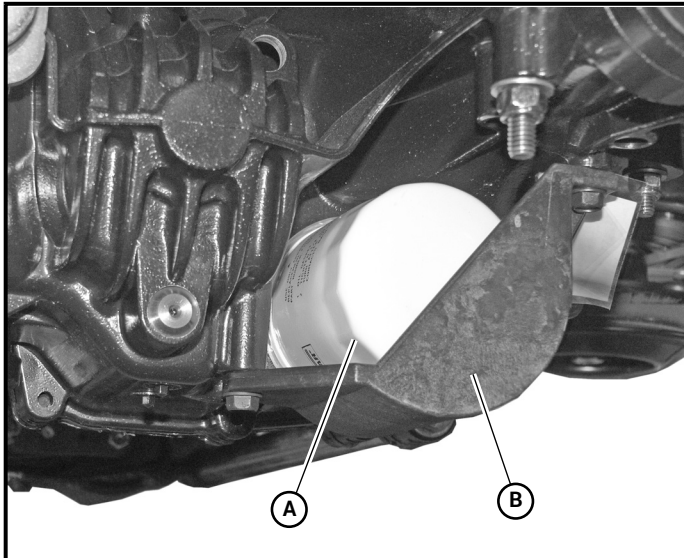

A. Filter

B. Filter guard

Figure 4-12

Fluid Changing Procedure

1. Park the unit on a level surface.
 - Place the steering control levers in the park brake position.
 - Disengage the deck clutch.
 - Remove the ignition switch key.
 - Disconnect the negative battery cable.
2. Remove the three 1/4" filter guard screws and filter guard. Clean any loose debris from around the filter. Figure 4-13
3. Place an oil drain pan beneath the oil filter and remove the oil filter from the transaxle.

4. After the oil has been drained, wipe the filter base surface off and apply a film of new oil to the gasket of the new replacement filter.
5. Install the new filter by hand, turn 3/4 to one full turn after the filter gasket contacts the filter base surface.
6. Re-install the filter guard with three 1/4" screws. Torque the screws to 65 in.-lbs. each. Figure 4-13
7. Repeat steps 2–6 for the opposite side transaxle.
8. Drain oil filters of all free flowing oil prior to disposal. Place used oil in appropriate containers.
9. **IMPORTANT:** Remove the top port plug from both transaxles prior to filling with oil. This will allow the transaxles to vent during oil fill. Figure 4-14
10. Remove the cap from the transaxle's expansion tank.
11. Fill with SAE 20W50 motor oil, 15W50 synthetic oil or 20W50 synthetic oil until oil just appears at the bottom of each transaxles top port (approximately 2 qts. per transaxle). Install the top port plug into each transaxle. Torque plugs to 180 in.-lbs. Clean up any oil that leaked from the ports. Figure 4-14

NOTE: Hustler® Full Synthetic 20W50 Hydrostatic Transmission Oil is recommended.

12. Continue to fill the transaxles through the expansion tank until the "Full Cold" line is reached on the expansion tank.
13. Re-install the expansion tank cap by hand. Be careful not to overtighten.
14. Proceed to the purge procedure.

IMPORTANT: Purging procedures must be followed after changing the oil and filter. Refer to *Purging Procedure* section for detailed information.

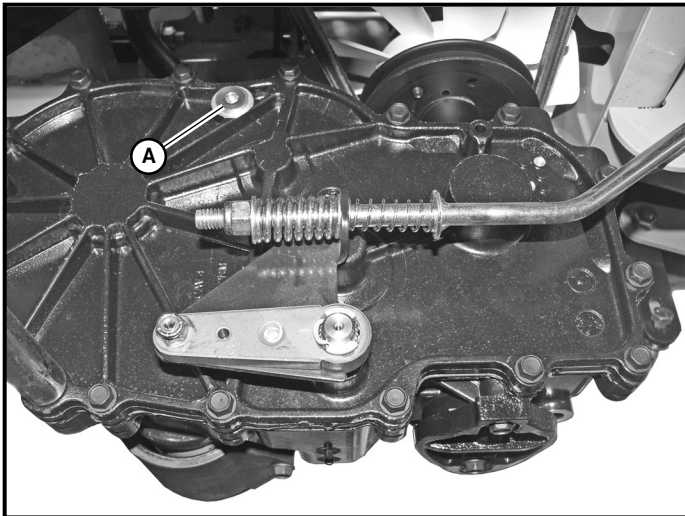

A. Top port plug

Figure 4-14

IMPORTANT: When washing the mower, direct the spray away (especially if using a power washer) from the transaxle's seals to prevent water intrusion and to ensure component performance.

Purging Procedure

Due to the effects air has on efficiency in hydrostatic drive applications, it is critical that air is purged from the system.

Air creates inefficiency because its compression and expansion rate is higher than that of the oil approved for use in hydrostatic drive systems.

These purge procedures should be implemented any time a hydrostatic system has been opened to facilitate maintenance or the oil has been changed.

The resulting symptoms in hydrostatic systems may be:

- Noisy operation.
- Lack of power or drive after short term operation.
- High operation temperature and excessive expansion of oil.

Before starting, make sure the transaxle is at the proper oil level. If it is not, fill to the specifications outlined in this manual.

The following procedures are best performed with the vehicle drive wheels off the ground and then repeated under normal operating conditions. If this is not possible, then the procedure should be performed in an open area free of any objects or bystanders.

1. Raise the rear of the mower and block with certified jack stands. The rear wheels need to be able to rotate freely and clear of all obstructions.



Never work under the machine or attachment unless it is safely supported with jack stands.

- Make certain machine is secure when it is raised and placed on the jack stands.
- **Use only certified jack stands.** Use only appropriate jack stands, with a minimum weight rating of 2000 pounds (907 kg) to block the unit up.
- Use in pairs only.
- Follow the instructions supplied with the jack stands.
- The jack stands should not allow the machine to move when the engine is running and the drive wheels are rotating.
- Do not allow the wheels to come in contact with the floor or any object that would permit the unit to propel itself.
- To prevent injury stay clear and exercise caution when rotating the wheels.



Exercise extreme caution when the transmissions are engaged.

- Keep hands, hair, clothing, etc., clear of the cooling fans on top of the transmissions to prevent entanglement.



Untrained maintenance personnel should never attempt to make any adjustments or repairs to the mower's drive system while the engine is running. **The following procedures should be performed by trained maintenance personnel only.**

2. Chock the front tires.
3. Unbolt or unlatch the seat platform from the mower frame. If the seat platform has a latch, unlatch it and pivot it forward to allow access to the seat switch on the underneath side of the seat.
 - Disconnect the mower harness from the seat switch.
 - Bypass the seat switch by connecting the two mower harness female spade connectors together. Figure 1-2
 - Secure the seat platform to the mower frame.

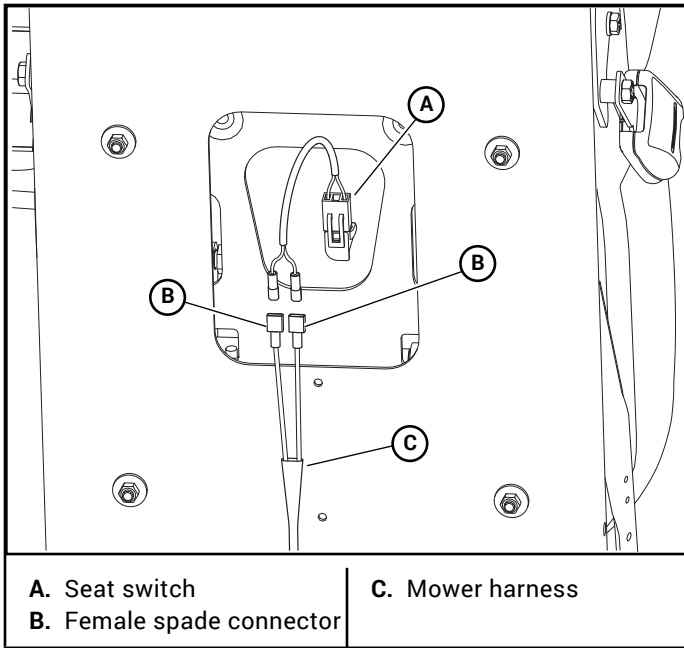

A. Seat switch
B. Female spade connector
C. Mower harness

Figure 4-15

Shown with steering control levers in the neutral position

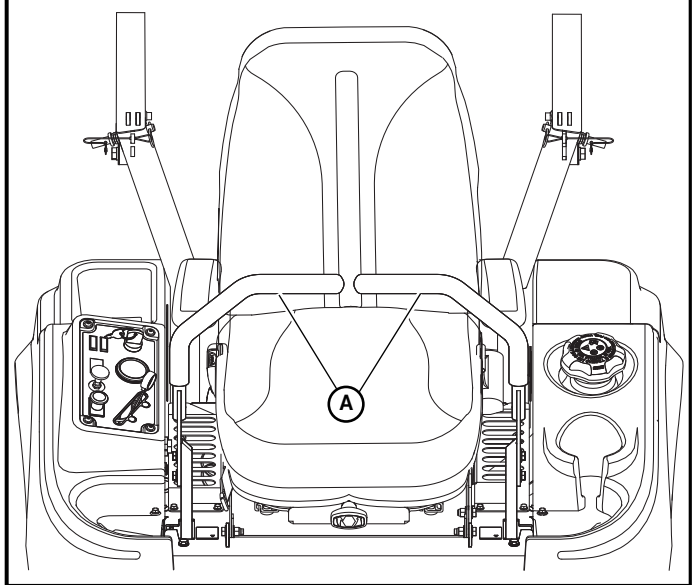

A. Steering control lever

Figure 4-17

- It may be necessary to repeat Steps 6 and 7 until all the air is completely purged from the system. When the transaxle operates at normal noise levels and moves smoothly forward and reverse at normal speeds, then the transaxle is considered purged.

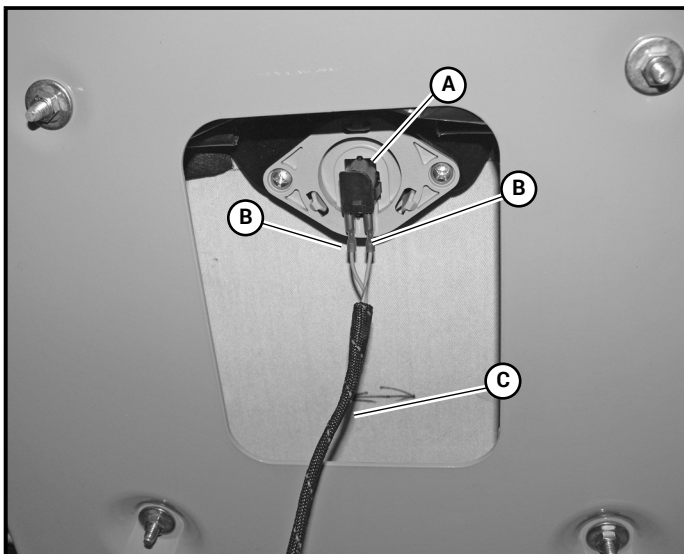

A. Seat switch
B. Female spade connector
C. Mower harness

Figure 4-16

- Start the engine.
- Position the steering control lever in the neutral position. Figure 1-3
IMPORTANT: Make sure the deck clutch switch is in the "OFF" (disengaged) position.
- With the bypass valve open and the engine running, slowly move the steering control lever in both forward and reverse directions (5 or 6 times). Figure 1-4
- With the bypass valve closed and the engine running, slowly move the steering control lever in both forward and reverse directions (5 or 6 times). Check the oil level, and add oil as required after stopping the engine.

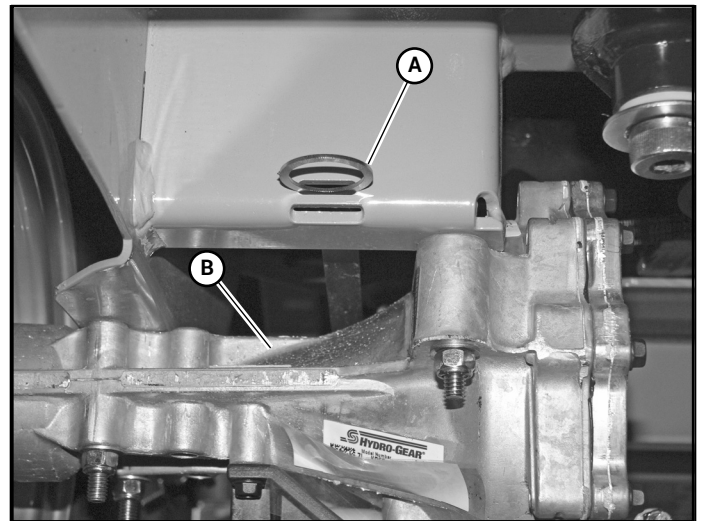

A. Bypass valve rod
B. Transaxle

Figure 4-18

- Unbolt or unlatch the seat platform from the mower frame. If the seat platform has a latch, unlatch it and pivot it forward to allow access to the seat switch on the underneath side of the seat.
 - Disconnect the two female spade connectors from each other (from step #3).

- Reconnect the two female spade connectors to the seat switch. This must be completed so that the safety circuit is functioning properly. Figure 1-2
- Secure the seat platform to the mower frame.

WARNING ⚠ Do not operate the mower without plugging the mower's wiring harness into the seat switch. This switch is an important part of the safety start interlock system. Serious injury can result if the seat switch is not plugged into the mower's wiring harness.

WARNING ⚠ Never operate the mower with a non-functioning seat switch. Always reconnect the seat switch to the mower harness.

WARNING ⚠ Never operate the mower with the seat platform improperly secured. The seat platform must be securely latched/bolted to prevent the seat from moving/tilting in the event of mower tipping or roll-over.

Tires

It is important for level mowing that the tires have the same amount of air pressure. The recommended pressures are:

Drive wheels 8–12 psi (55–83 KPa)

Front wheels 8–12 psi (55–83 KPa)

If you wish to use non-pneumatic tires on your Hustler® mower, the tire must be a Hustler® approved tire. Warranty claims will be denied on any mower equipped with unapproved non-pneumatic tires.

ENGINE MAINTENANCE

General Engine Maintenance

Detailed instructions and recommendations for break-in and regular maintenance are specified in the *Engine Owner's Manual*. Please refer to this manual for engine servicing, lubricating oil levels with quality and viscosity recommendations, bolt torques, etc. The engine warranty is backed by the engine manufacturer. Special attention should be paid to applicable data which will not be duplicated here.

Engine Oil and Filter



Allow the engine to cool before changing the engine oil. If the engine has been running, use caution when changing the engine oil as it will be very hot. You should wear the appropriate protective gear to avoid being burned or exposed to engine oil.

Check the engine oil daily and after every 4 hours of operation. The mower must be level when checking the oil. Refer to the *Engine Owner's Manual* and maintenance schedule for oil recommendation and capacities. Hustler® Motor Oil is recommended.

Change the engine oil and filter after the first 5 hours of operation and per the engine manufacturer's recommendations after that. Change the engine oil more frequently if operating in extremely dirty conditions.

IMPORTANT: After the new oil filter has been installed, clean up any oil which may have spilled onto the engine plate, engine exhaust system, and muffler guard.

Draining the Engine Oil:

1. Locate the oil drain valve on the lower right side of the engine. Figure 5-1 & Figure 5-2
2. Position a suitable oil drain container under the oil drain valve to catch the oil as it drains from the engine.
3. Use a 10 mm wrench or socket and open the valve approximately 4 turns in the counterclockwise direction. Allow 10 minutes for engine oil to adequately drain.
4. After oil is drained, close the valve by turning it in the clockwise direction until it is fully closed.
5. Remove the oil drain container from under the mower.

IMPORTANT: All oil drips or spills **must** be cleaned off of the engine plate, engine exhaust system, and muffler guard before operating the machine.

Kawasaki engine shown

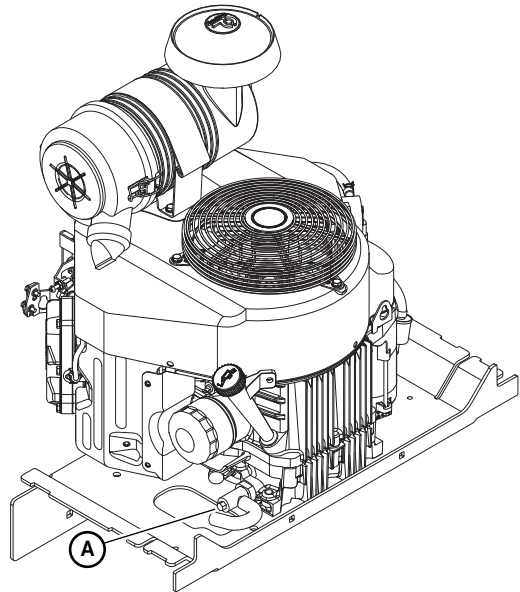

A. Oil drain valve

Figure 5-1

Kohler engine shown

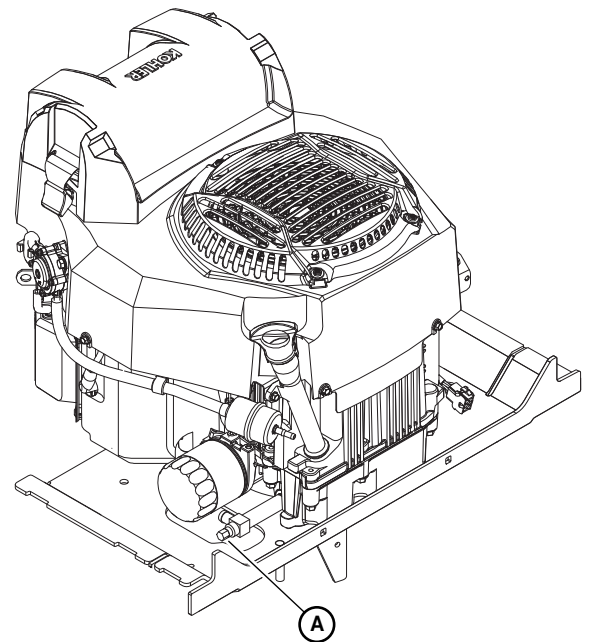

A. Oil drain valve

Figure 5-2

Engine Air Filter

Perform engine air filter maintenance per the *Maintenance Schedule* shown elsewhere in this manual.

A specially designed dry filter is standard equipment on these mowers and supplies clean combustion air to the engine. Figure 5-3 & Figure 5-5

Some of these mowers are equipped with a safety filter. The filter element slides over the safety filter. Figure 5-4 & Figure 5-6

The safety filter does not require servicing unless it becomes contaminated with dirt or moisture.

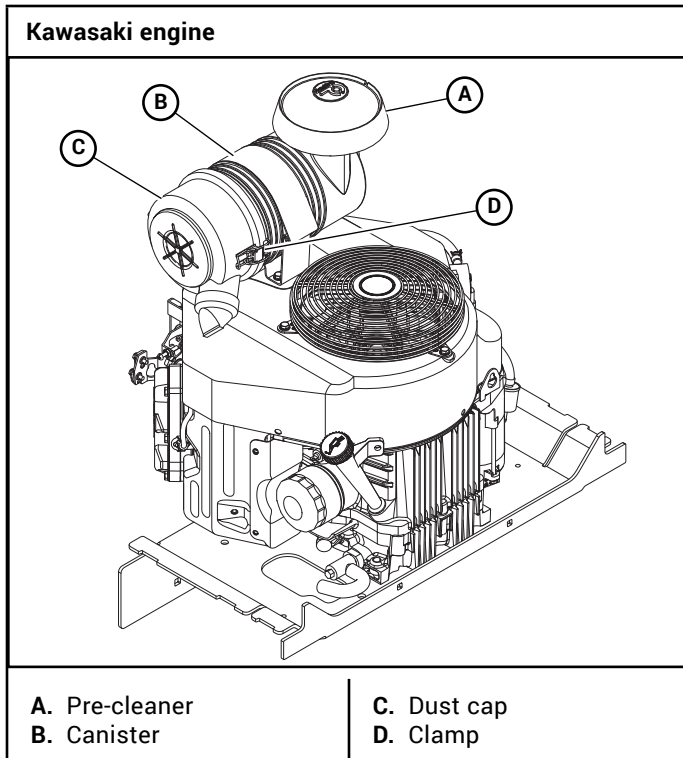

Figure 5-3

Recommended Service Procedure

1. Release clamps and remove element. Clean the air cleaner canister with a damp cloth.
2. Before installing a new element, inspect it by placing a bright light inside and rotating the element slowly, looking for any holes or tears in the paper. Also check gaskets for cuts or tears. Do not attempt to use a damaged element which will allow abrasive particles to enter the engine.
3. **Kawasaki engines** – Reinstall the dust cap. Make sure it seals all the way around the air cleaner canister, then tighten the clamps. Figure 5-7

Kohler engines – Reinstall the top of the canister housing. Make sure it seals all the way around the lower part of the housing, then tighten the clamps. Figure 5-8

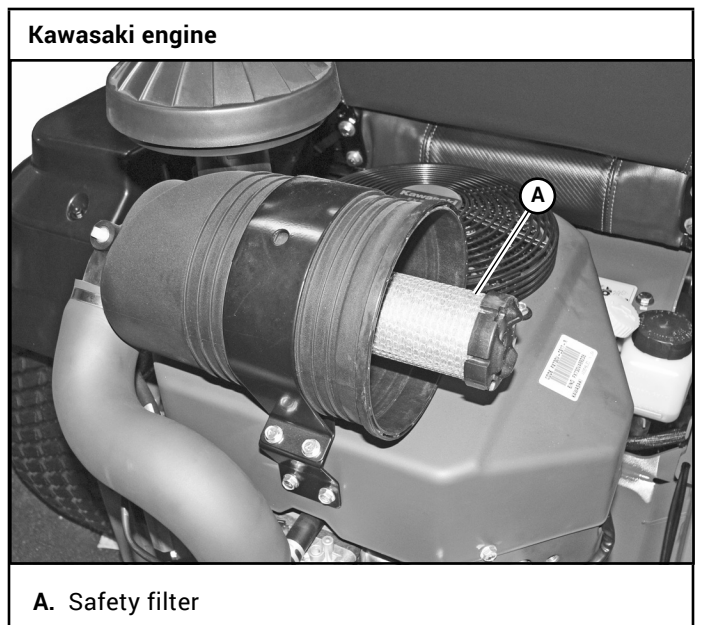

Figure 5-4

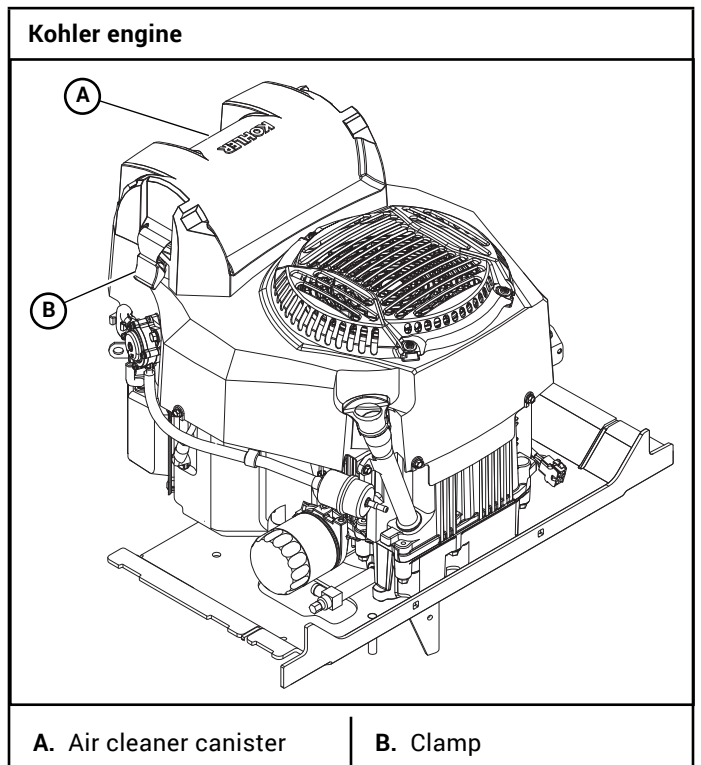

Figure 5-5

4. **Kawasaki engines** – Check all fittings and clamps periodically for tightness and inspect hoses for holes or cracks.
5. **Kawasaki engines** – Periodically check the intake hose for signs of ingested dust. Locate and repair the source of ingested dirt.
6. Never operate the machine without an air filter installed.

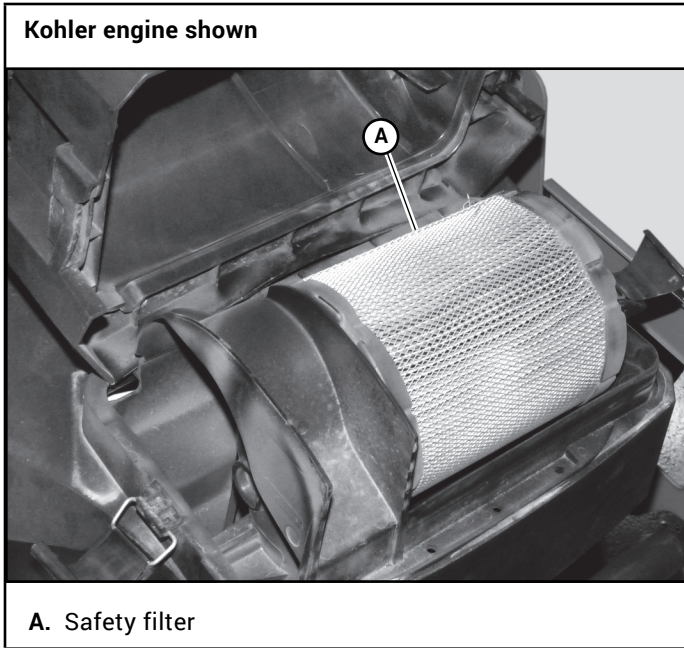

Figure 5-6

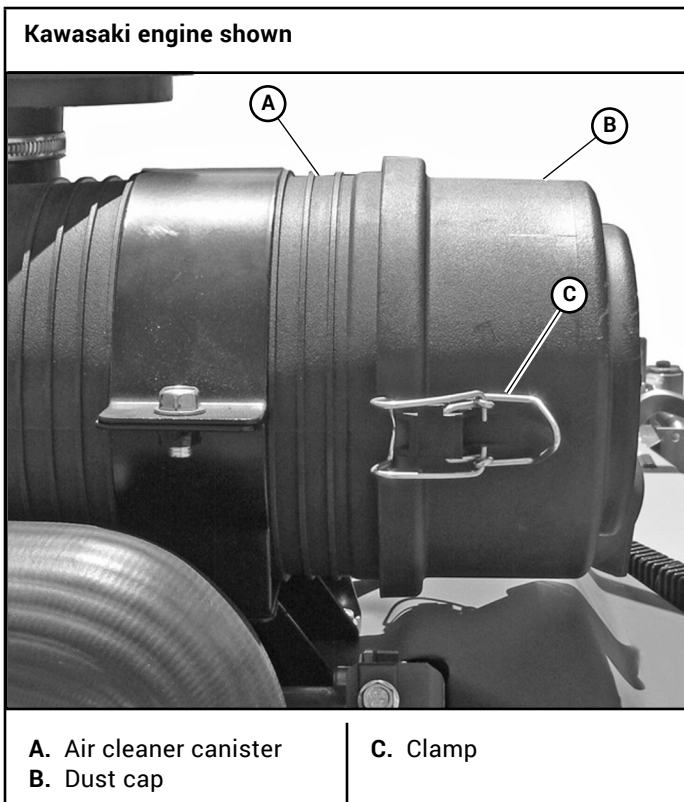

Figure 5-7

Overservicing

Overservicing occurs when an air filter element is removed for cleaning or replacement before it is necessary. Each time the filter is removed a small amount of dirt and dust could fall in the intake system. This accumulated dirt can cause a dusted engine. It only takes a few grams of ingested dirt over the normal service life of an engine to cause a dusted engine.

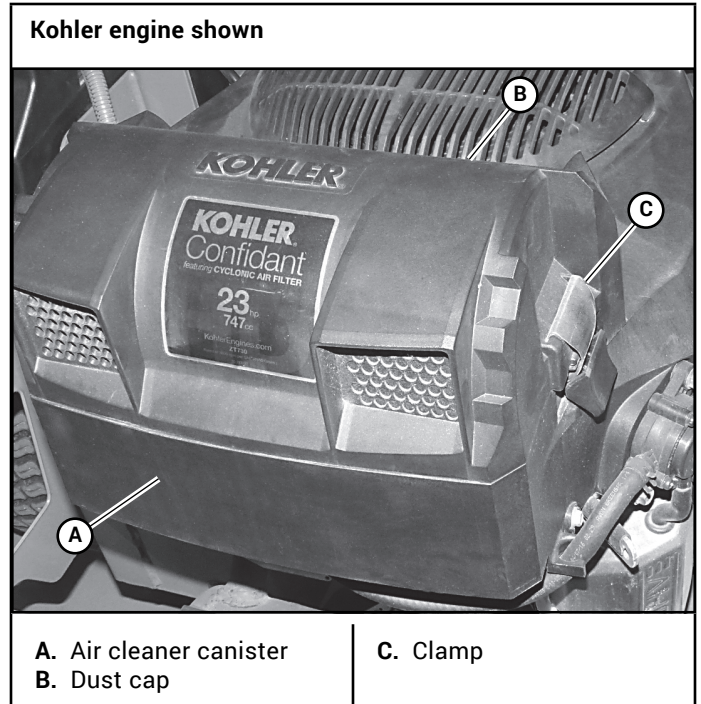

Figure 5-8

Do not clean the element, but replace with a new element only. Cleaning used air filter elements, through improper cleaning procedures, can get dust on the inside of the filter causing dirt ingestion and engine failure.

It is important to note that whenever an air filter element is cleaned by **any method**, the person or company performing the cleaning assumes responsibility for the integrity of the filter from then on. **The warranty for air filters expires upon cleaning or servicing in any manner because the condition of the filter after servicing is completely out of the filter manufacturer's control. Therefore, on a dust ingested engine failure, there will be no warranty consideration if the air filter element has been cleaned or serviced in any manner.**

A partially dirty air filter element works better than a new element. Therefore, a dirty filter element is not bad for the engine unless it is excessively restricting the air flow and engine performance is affected. The reason is simple. The media in the filter must be porous to allow air to pass through it. When dirty air passes through the filter, the dirt plugs some of the holes in the media and actually acts as part of the filter media. When the next round of dirt enters, the first dirt helps filter out even smaller particles making the filter more efficient at stopping dirt from entering the engine. This is referred to as barrier filtration.

Of course, at some point the filter media becomes too clogged to allow air to pass.

The mowing conditions will determine the frequency of air filter element changing.

Carbon Canister

FasTrak® SDX mowers, that are put into operation in California, have a carbon canister incorporated into the fuel system. Figure 5-9

California requires all mowers using gasoline engines to have this feature.

These canisters should be replaced every 5 years or if they become damaged.

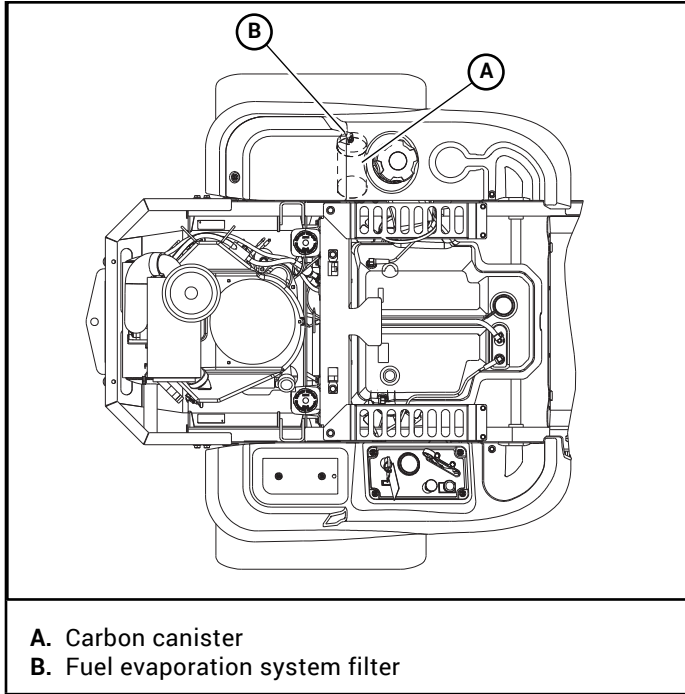

Figure 5-9

Fuel Evaporation System Filter

Hustler® FasTrak® SDX mowers have a fuel evaporation system filter. This filter must be checked and replaced every 300 hours or annually whichever comes first. Figure 5-10 & Figure 5-11

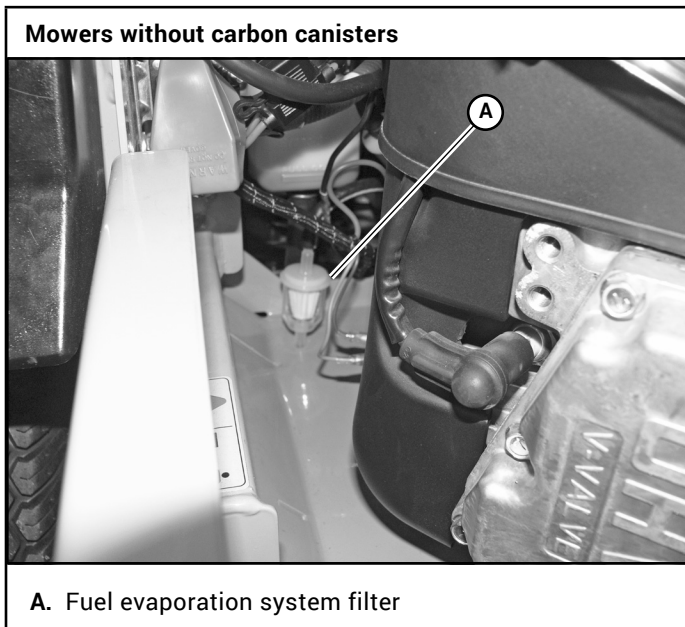

Figure 5-10

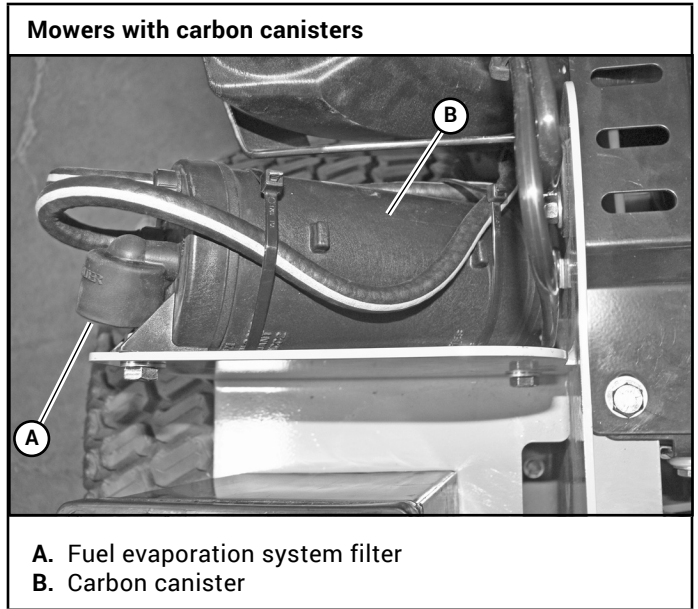

Figure 5-11

Fuel & Evaporative System Line Routings

These mowers have a fuel evaporative system installed. There are two different types of rubber hoses that are connected to the fuel tank. One is the fuel hose that is part of the fuel system. The other is the vapor line that is part of the fuel evaporative system.

The fuel hose is connected to the fuel tank as shown. It connects the fuel tank to the engine's fuel pump. Figure 5-12 & Figure 5-13

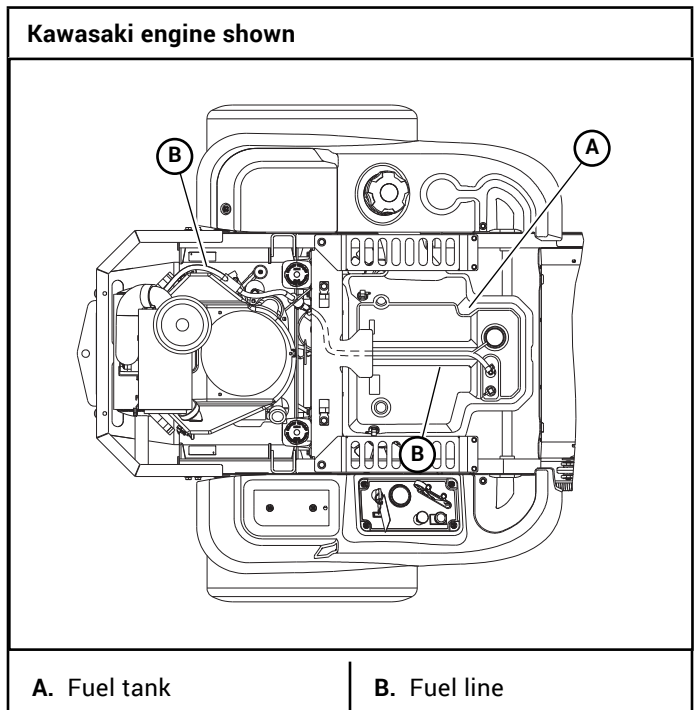

Figure 5-12

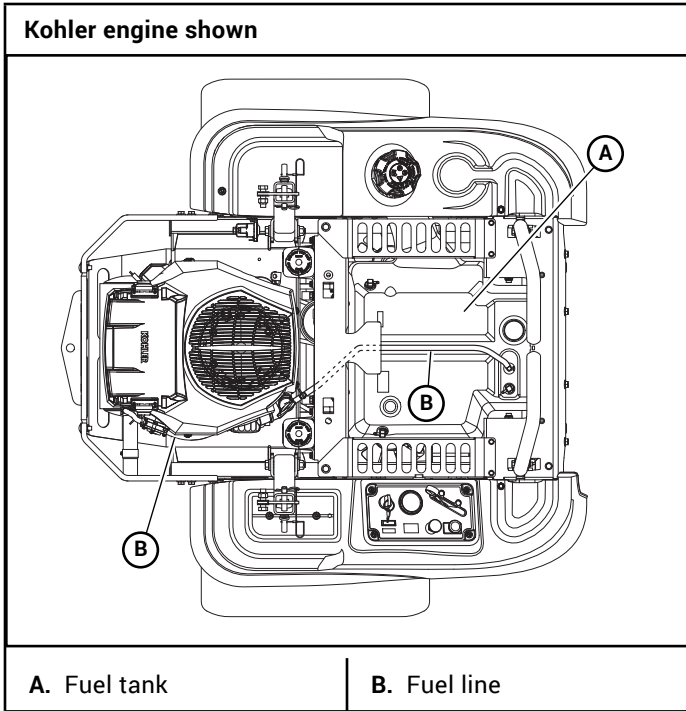

Figure 5-13

The vapor lines are connected to the fuel tank as shown. They connect the fuel tank to the engine's vapor port. Figure 5-14, Figure 5-15 & Figure 5-16

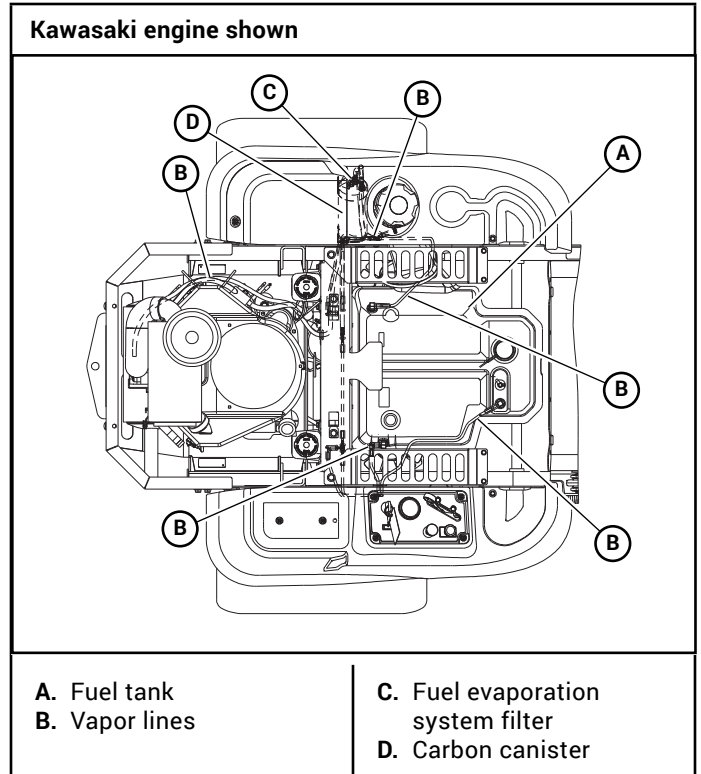

Figure 5-15

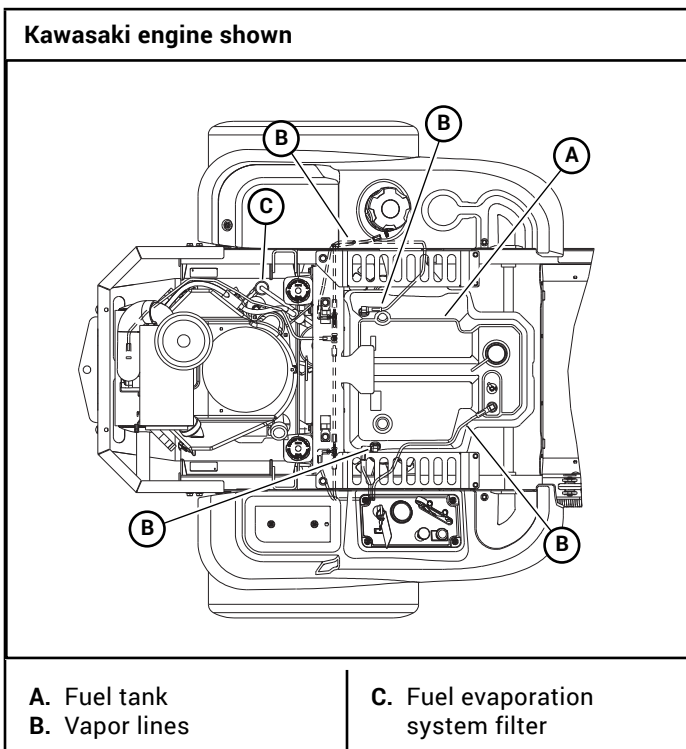

Figure 5-14

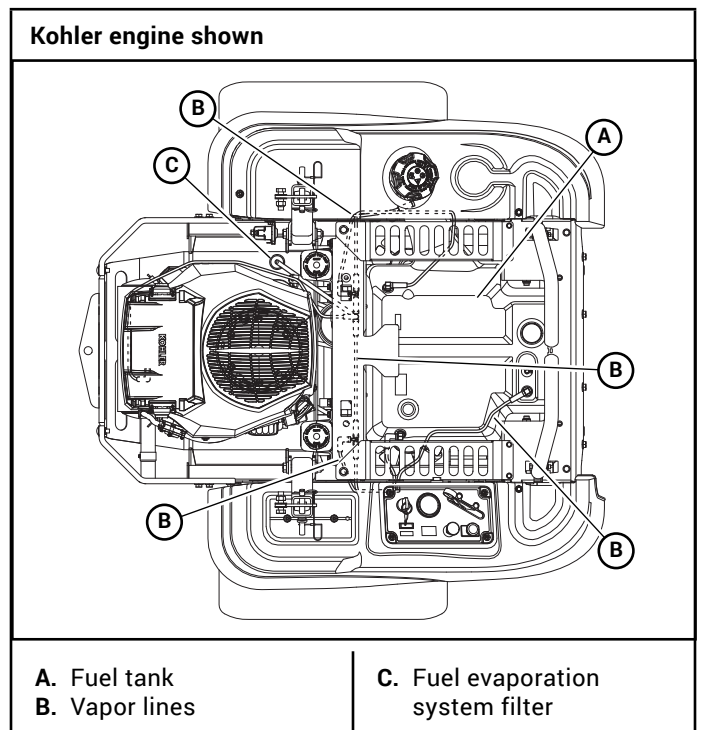

Figure 5-16

Engine RPM Settings

The engine rpm's are set at the factory for maximum mowing efficiency. Occasionally it may be necessary to check and adjust the settings. The idle speeds should be set as follows:

Kawasaki FX691 / FX730	
ENGINE SPEEDS	
MODEL NO. ENDING WITH:	HIGH IDLE
Model NO. without extension Model NO. with EX extension Model NO. with US extension	3600 ± 50 rpm
Model NO. with CE extension	2800 ± 50 rpm
Kohler ZT730 / ZT740	
ENGINE SPEEDS	
MODEL NO. ENDING WITH:	HIGH IDLE
Model NO. without extension Model NO. with EX extension Model NO. with US extension	3600 ± 50 rpm

NOTE: Model numbers may or may not end with an extension after the number. There are several different extensions that may be shown; i.e. EX, AU or CE.

Example: 922222 (no extension)

922222 EX

922222 CE

922222 US

922222 AU

DECK ADJUSTMENTS

Deck Leveling

Leveling the deck must be done in the following manner and order:

1. Check tire pressures to make certain they are properly inflated before starting to level deck. The recommended pressures are as follows:

Drive wheels tire pressure 8–12 psi
Front wheels tire pressure 8–12 psi

WARNING Stop engine. Make sure the deck clutch switch is **in the down (OFF) position**. Place the steering control levers in the park brake position before leaving the machine.

2. Park the unit on a hard flat surface.
3. Using the deck lift pedal, raise and lock the deck in the transport position. Figure 6-3
4. Place 3" (76.2 mm) high deck support blocks (two stacked 2" x 4" blocks can be used to create a 3" [76.2 mm] high support) at the four corners of the deck as shown. **NOTE:** The back of deck will automatically be set 1/4" (6.35 mm) higher. Figure 6-1 & Figure 6-2
5. Remove the height adjusting stop pin and lower the deck until it rests on the support blocks. Figure 6-3
6. Loosen the four flange nuts attaching the four deck links to the deck. Figure 6-3
7. Push the deck lift pedal forward, place the height adjusting stop pin in the indicator hole marked 3.25" (82.6 mm) and release the pedal.
8. Unscrew the nut from the eyebolt and slide the eyebolt out of the mount. This removes the tension from the deck lift assist spring. Figure 6-4
9. Pull the pedal rearward so that the transport latch is held firmly against the deck height adjusting stop pin and the play in the pivot joint is removed; secure the pedal in this position (a bungee cord may be used).
10. Tighten the four deck links to the deck with the flange nuts clamping on either side of the slot with 48 ft-lbs (65 N·m) of torque. Release the deck lift pedal and ensure that the deck can be raised and locked into the transport position. Figure 6-3

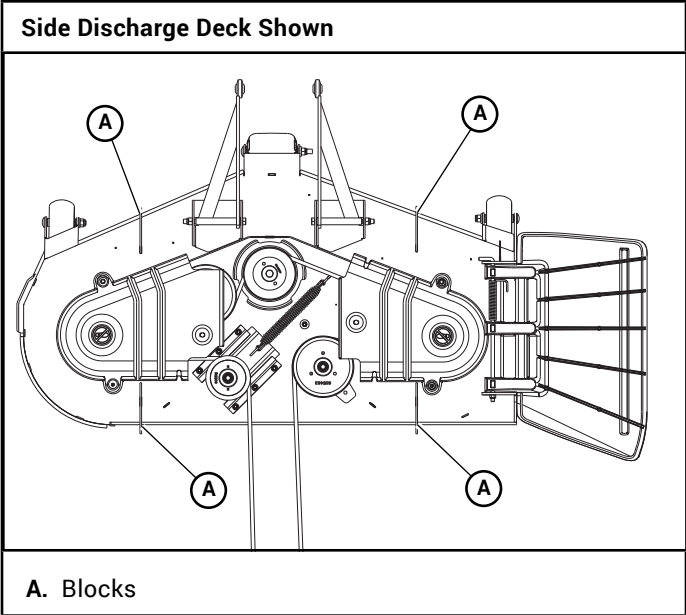

Figure 6-1

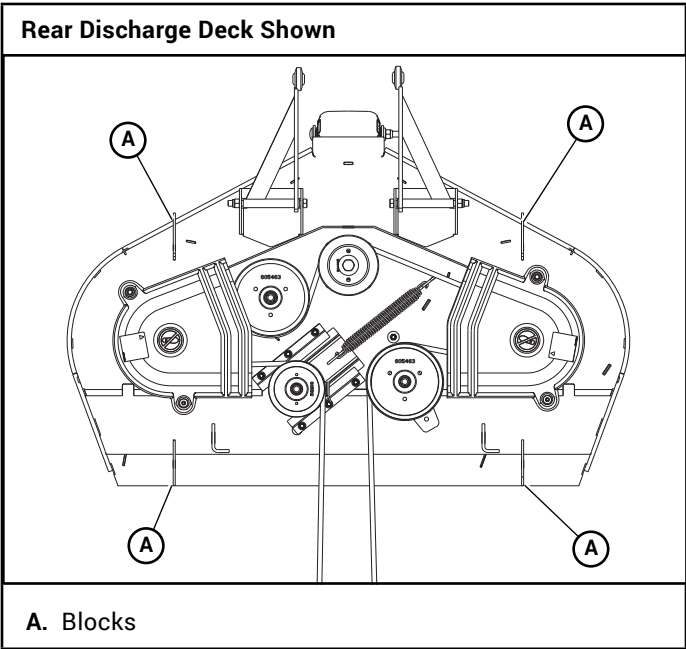

Figure 6-2

11. Reinstall the eyebolt and deck lift assist spring. Adjust the spring tension using the lock nut and nut on the eyebolt. The spring extension should be 9.50" (241.3 mm) when locked in the transport position. Figure 6-4

Blades

Mower Blade Maintenance

IMPORTANT: Refer to the *Safety* section of this manual for blade handling safety information.

Refer to the *Mower Blade Replacement* section for blade removal and installation.

WARNING	▲
	Mower blades are sharp and can cut. Wrap the blade(s) or wear gloves and use extra caution when servicing them.

Check the mower blades daily, they are the key to power efficiency and well groomed turf. Keep the blades sharp. A dull blade will tear rather than cut the grass, leaving a brown ragged top on the grass within a few hours. A dull blade also requires more power from the engine.

Replace any blade which is bent, cracked or broken.

WARNING	▲	Always check for blade damage:
		<ul style="list-style-type: none"> • if mower strikes a rock, branch or other foreign object during mowing! • or if an abnormal vibration occurs while operating. <p>Make all necessary repairs before resuming operation.</p>

Sharpen the blades following the pattern shown. Touch-up sharpening can be done with a file. Figure 6-5

After grinding the blades, check for balance. Blade balancing can be done by placing the blade on an inverted line punch or 5/8" bolt. A commercial balancing tool is also available through most hardware supply stores.

The blade should not lean or tilt. When spinning the blade slowly it should not wobble. Balance the blade before reinstalling.

Lay the blade on a flat surface and check for distortion. Replace any distorted blade. Figure 6-6 & Figure 6-7

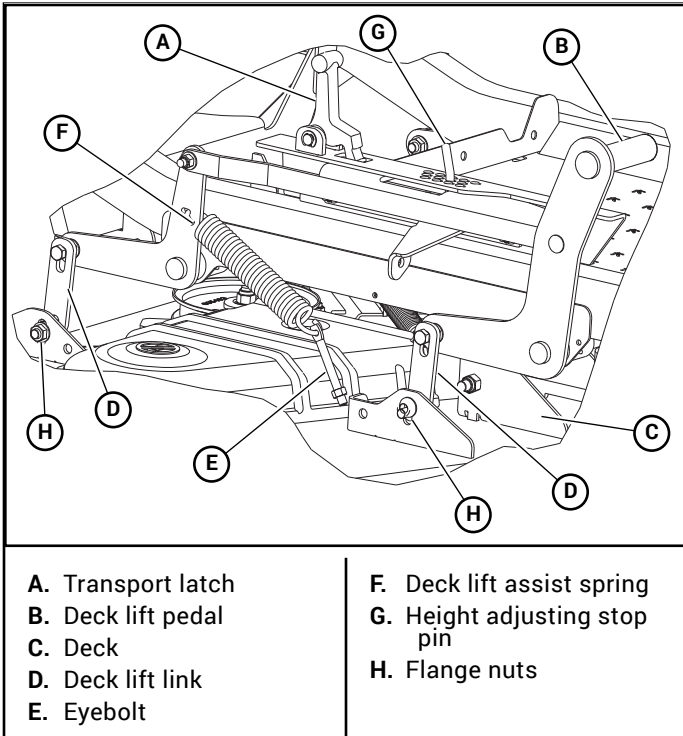

Figure 6-3

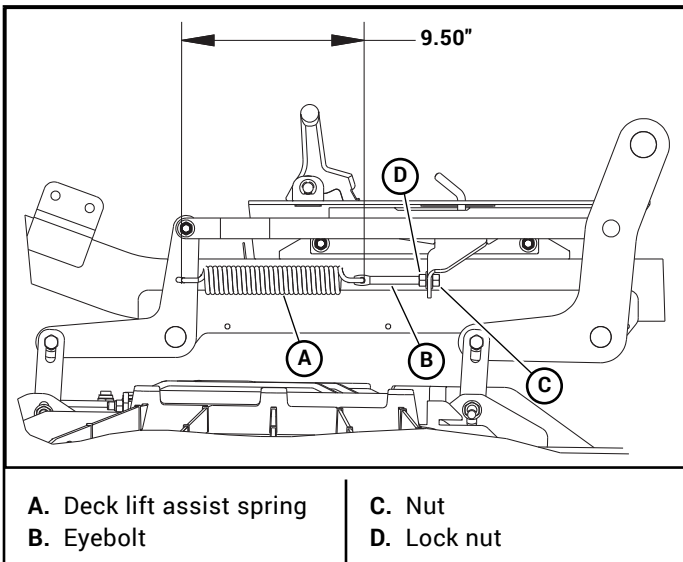

Figure 6-4

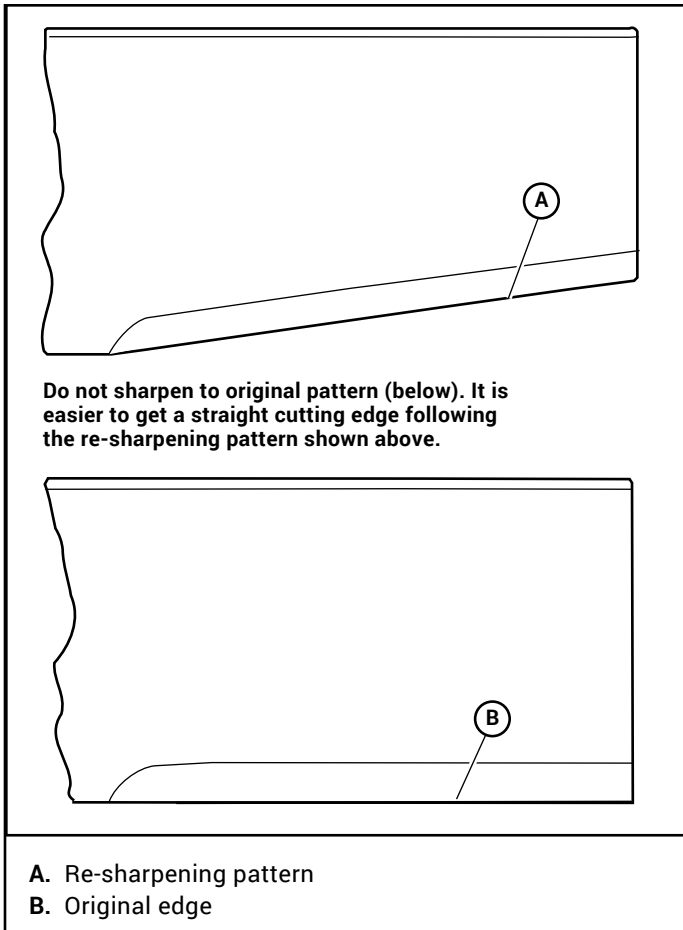

Figure 6-5

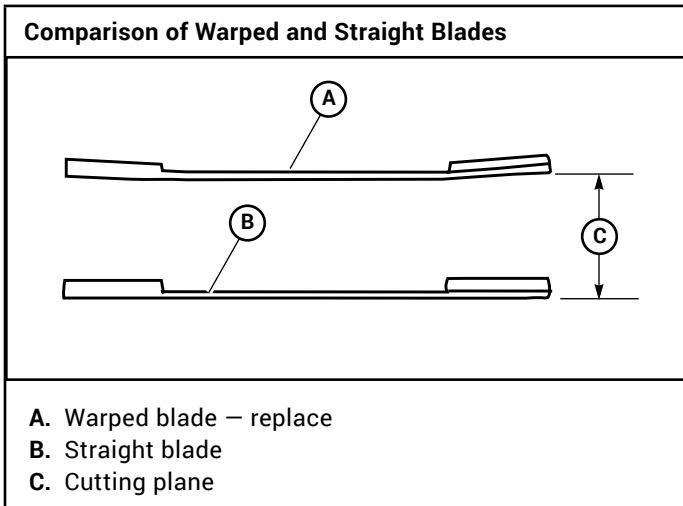

Figure 6-6

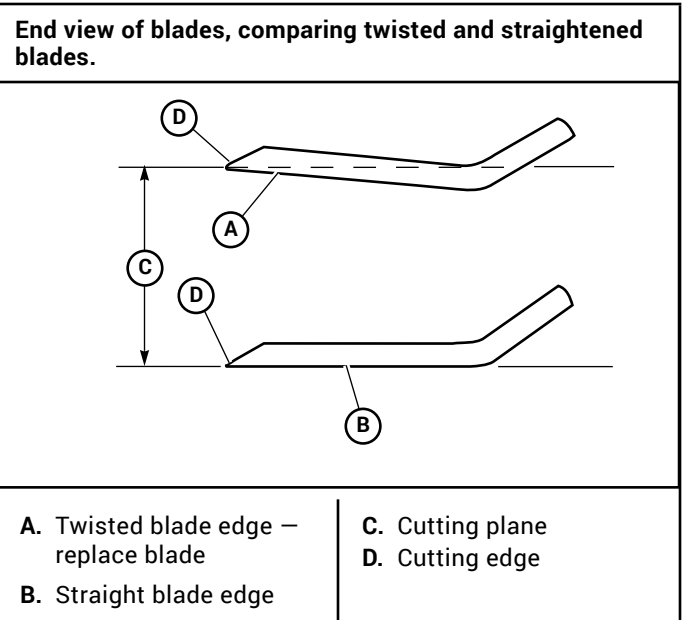

Figure 6-7

Mower Blade Removal

IMPORTANT: Refer to the *Safety* section of this manual for blade handling safety information.



Mower blades are sharp and can cut. Wrap the blade(s) or wear gloves and use extra caution when servicing them.

A 15/16" wrench is required to remove the 5/8" cap screw holding the blade to the spindle shaft. **NOTE:** A blade holding tool (P/N 381442) is available from Hustler® Turf Equipment. It is designed to prevent the blades from rotating when they are being removed or installed on the spindle. Contact your Hustler® Dealer for more information.

Do not re-use spindle bolts which have stripped, worn or undercut threads. Torque bolts on spindles to 118 ft-lbs (160.0 N•m) when reinstalling blades.



Failure to correctly torque the bolt may result in the loss of the blade which can cause serious injury.

Properly compressed cup washers maintain the correct compression load on the blades. Replace the cup washers if they are cracked or flattened.

IMPORTANT: The blade sail (curved part) must be pointing upward toward the inside of the deck to ensure proper cutting.

When mounting blades, rotate them after installation to ensure blade tips do not touch each other or sides of the mower.

Belts

Inspect belts frequently for wear and serviceability. Replace a belt that shows signs of:

- severe cuts
- tears
- separation
- weather checking
- cracking
- burns caused by slipping.

Slight raveling of belt covering does not indicate failure, trim ravelings with a sharp knife.

Inspect the belt pulley grooves and flanges for wear. A new belt, or one in good condition, should never run against the bottom of the groove. Replace the pulley when this is the case, otherwise, the belt will lose power and slip excessively.

Never pry a belt to get it on a pulley as this will cut or damage the fibers of the belt covering.

Keep oil and grease away from belts, and never use belt dressings. Any of these will destroy the belt composition in a very short time.

Deck Belt Adjustment

The deck belt tension remains constant by means of a tension idler and spring. There is no tension adjustment of this belt. Figure 6-8

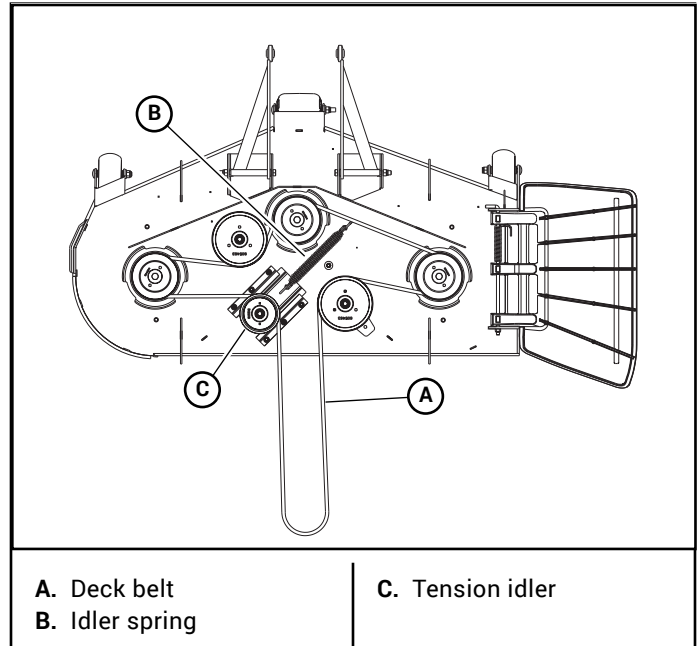

Figure 6-8

Deck Belt Installation

When replacing a deck belt use the following procedure:

1. Route the belt around all the pulleys except the left deck spindle.
2. Grasp the belt at the two locations shown and pull the belt over the left spindle pulley. Figure 6-9 & Figure 6-10
3. Release the belt.



Keep hands clear when pulling belt over the pulley to prevent pinching. **Do not** get hand or fingers between pulley and belt.

Side Discharge Deck Shown

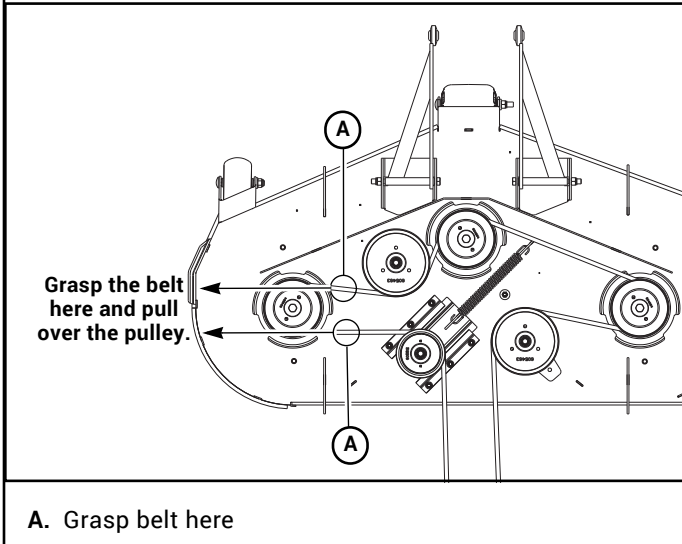

Figure 6-9

Rear Discharge Deck Shown

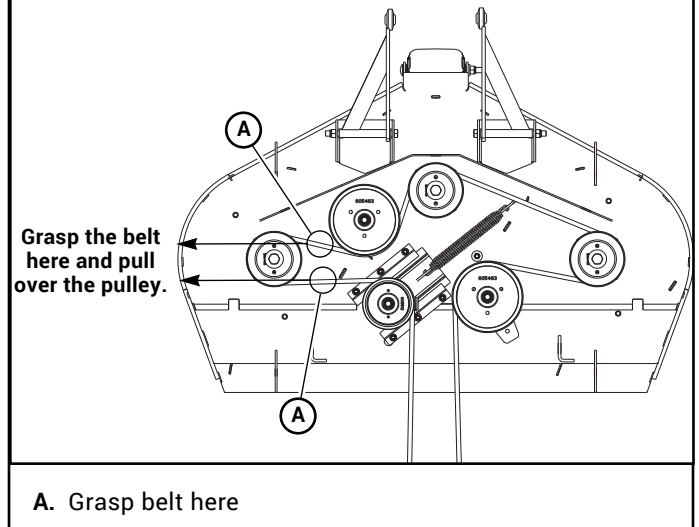

Figure 6-10

Belt Routing and Tensioning

The following notes are the same for the different decks that are available.

1. There is no tension adjustment of this belt.
2. Route belt as shown.

Side Discharge Deck Belt Routing

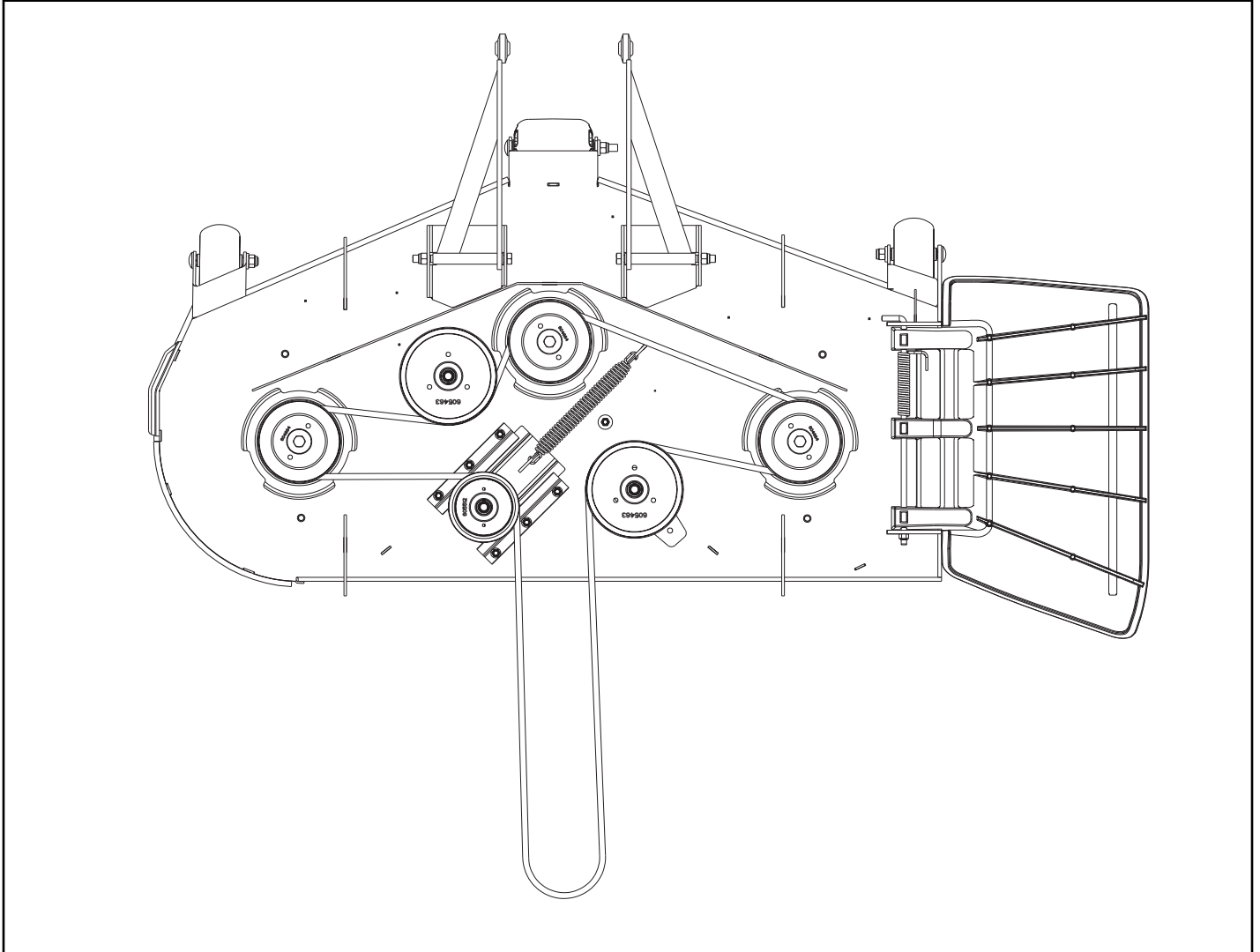

Figure 6-11

Rear Discharge Deck Belt Routing

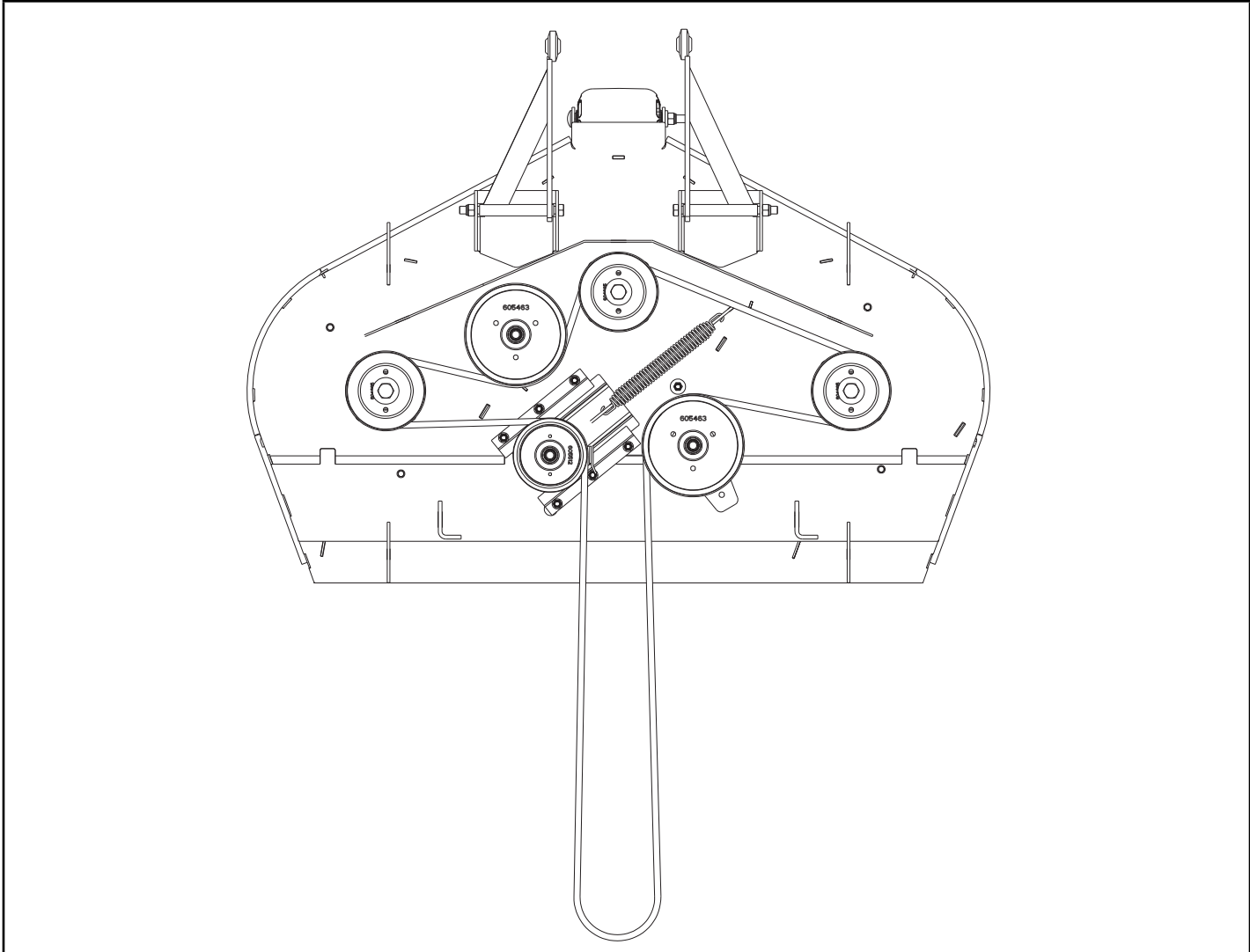
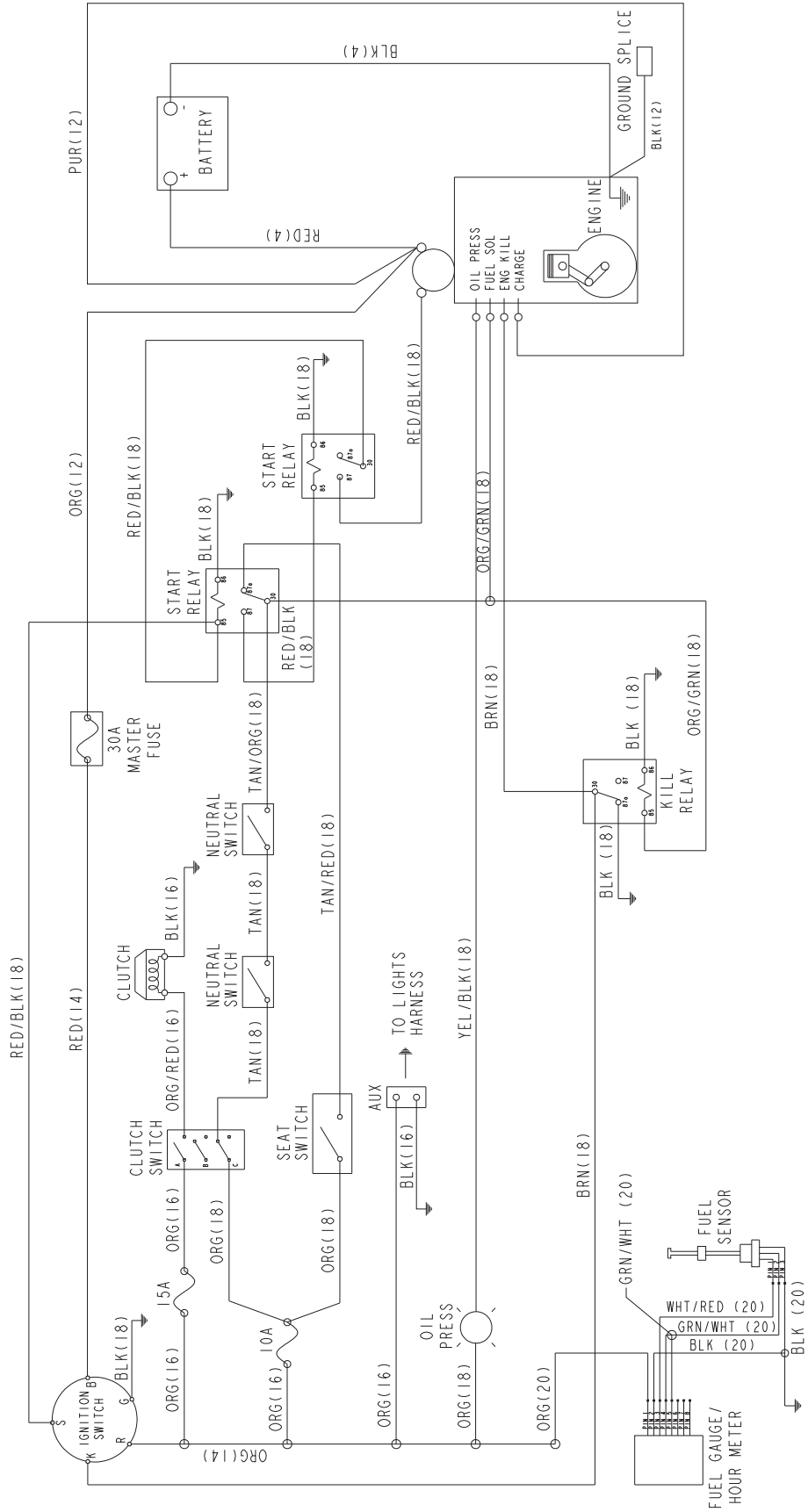

Figure 6-12

ELECTRICAL

Main Electrical Harness Schematic – Kawasaki



Main Electrical Harness Schematic – Kohler

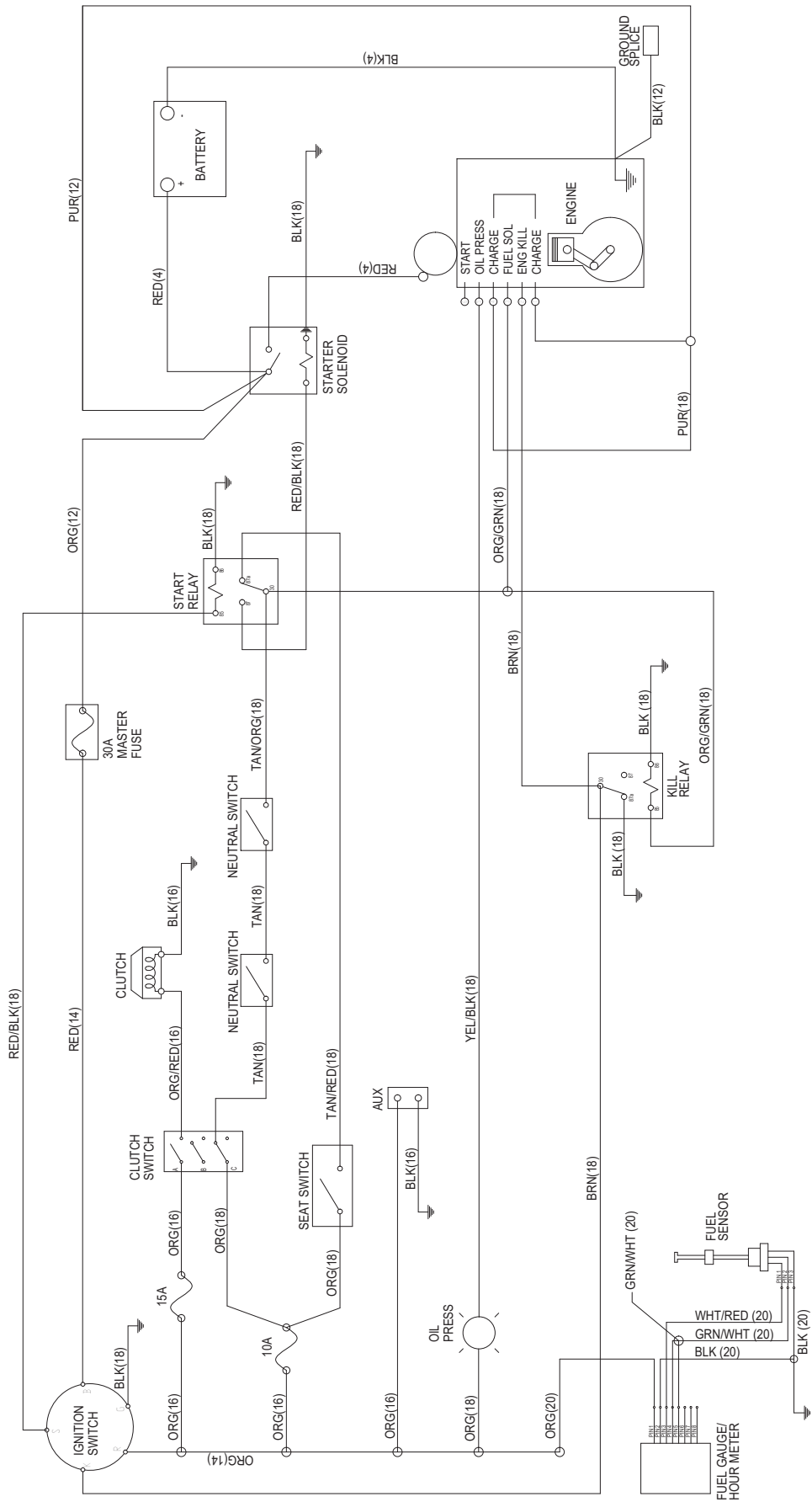

Main Harness to Fuel Gauge Voltage Converter Schematic-Kawasaki and Kohler

Used on mowers starting with serial number 17072792

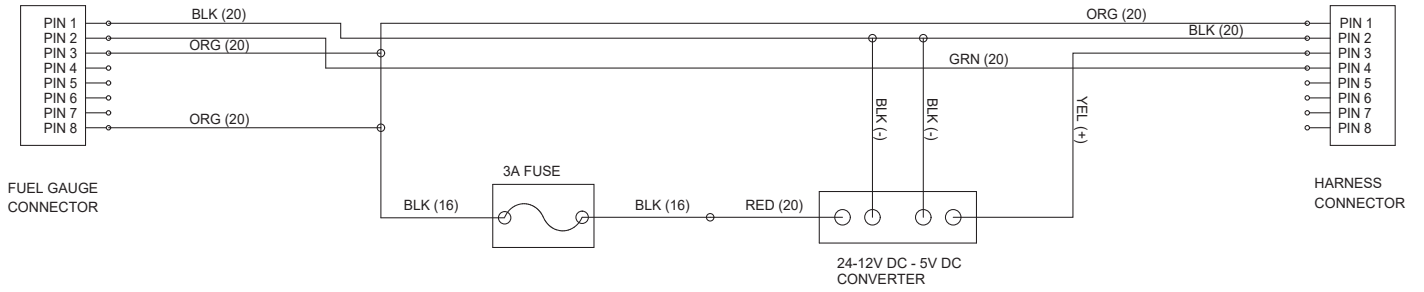

Used on mowers prior to serial number 17072792

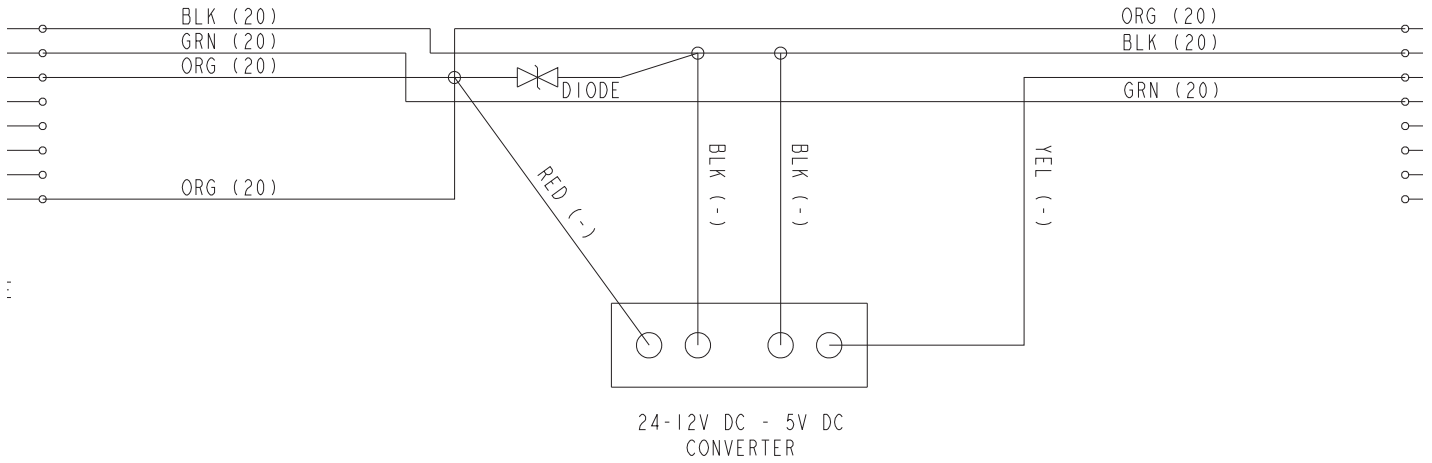

MAINTENANCE

Maintenance Schedule			
Figure 8-1, Figure 8-2, Figure 8-3, Figure 8-4, Figure 8-5, & Figure 8-6			
SERVICE AT INTERVALS INDICATED	WEEKLY OR 50 HOURS	MONTHLY OR 100 HOURS	* ANNUALLY OR 300 HOURS
Verify safety start interlock system	Prior to each use		
Visually inspect unit for loose hardware and/or damaged parts	Prior to each use		
Visually inspect tires	Prior to each use		
Check oil level, engine (1)	Prior to each use or every 4 hours		
Clean air intake screen (8)	Prior to each use or every 4 hours		
Clean foam element (4)(10)	Prior to each use or every 4 hours		
Check fuel level	Prior to each use		
Blades - sharpen & securely fastened	Prior to each use		
Discharge chute - securely in place & in lowest position	Prior to each use		
Clean engine and transaxle compartment	Daily		
Change transaxle oil and filter (7)	Every 200 hours or 2 years		
Replace engine air cleaner element (4)(10)	As needed		
Grease deck height pivots	X		
Grease front wheel bearings	X		
Change engine oil and filter (1) (3)	X		
Clean cylinder and head fins (10)	X		
Check battery connections	X		
Check tire pressure with a gauge	X		
Check hydraulic oil level	X		
Clean engine exterior (10)	X		
Clean & regap spark plugs (10)		X	
Check transaxle and deck belt tension and condition (5)		X	
Check fuel system (6)		X	
Check hydraulic lines		X	
Check fuel valve (6)		X	
Check fuel tank grommet (6)		X	
Tighten lug nuts on wheels (2)		X	
Change fuel filter (6)			X
Replace spark plugs (10)			X
Check ROPS mounting hardware (9)			X
Replace fuel evaporation system filter (8)			X

NOTES:

1. Initial engine oil change is after 5 hours of operation. Thereafter, change oil after every 40 hours operation. Change more often under dusty or dirty conditions and during hot weather periods. Hustler® Motor Oil is recommended.
2. Torque initially and after first 2 hours of operation.
3. Change engine oil filter per the engine manufacturer's recommendations. Refer to Engine Owner's Manual for recommendations and other maintenance items.
4. Service more often under dusty or dirty conditions. Use caution when servicing to prevent dust contamination in the engine. **Do not** clean filter element. Replace with a new one.
5. **Pump drive belt only - Inspect every 100 hours** and replace if worn or cracking is noticed. Otherwise, **replace every 200 hours or 2 years** whichever comes first.
6. Check fuel system for any cracks or leaks including, but not limited to, fuel line hoses, fuel valve, vent line hoses, vent valve, vapor valve, carbon canister, and grommets. Repair as needed.
7. Initial transaxle system oil and filter change **must** be after the first 75 hours of use or 1 year whichever comes first. Thereafter, replace filter and oil in each transaxle **every 2 years or 200 hours**, whichever comes first. Hustler® Full Synthetic 20W50 Hydrostatic Transmission Oil is recommended.

8. More often under dusty or dirty conditions and during hot weather.
9. Inspect ROPS after the first 20 hours of operation and then after every 300 hours of operation or yearly whichever comes first.
10. Refer to engine owner's manual for engine service information.

*After completing maintenance cycle (300 hours), repeat cycle.

Maintenance Locator Chart

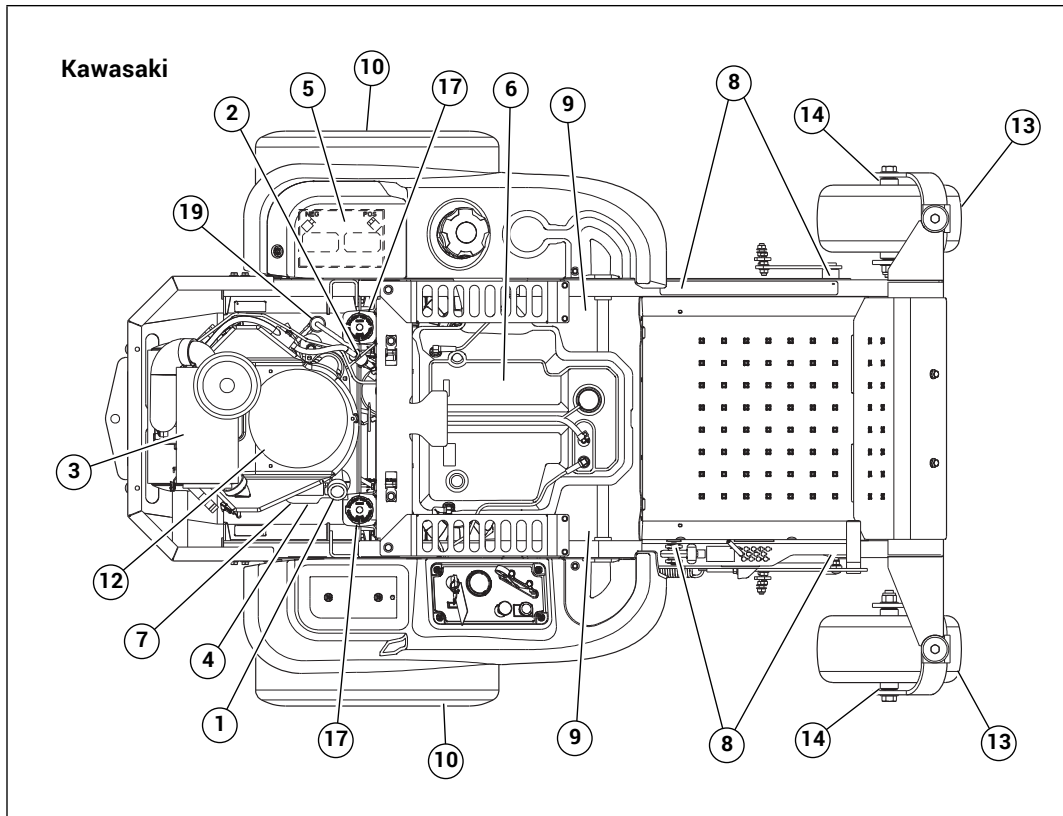

1. Engine Oil Fill & Dipstick
2. Fuel Filter
3. Engine Air Cleaner
4. Engine Oil Drain Valve
5. Battery
6. Fuel Tank
7. Engine Oil Filter
8. Deck Lift Pivot Zerk (4)
9. Park Brake Switch (2)
10. Drive Tire
11. Pump Belt
12. Engine Air Intake Screen
13. Front Wheel Tires
14. Front Wheel Zerks (2)
15. Deck Belt
16. Blades
17. Hydraulic Oil Expansion Tank
18. Hydraulic Oil Filter
19. Fuel Evaporation System Filter
20. Carbon Canister

Figure 8-1

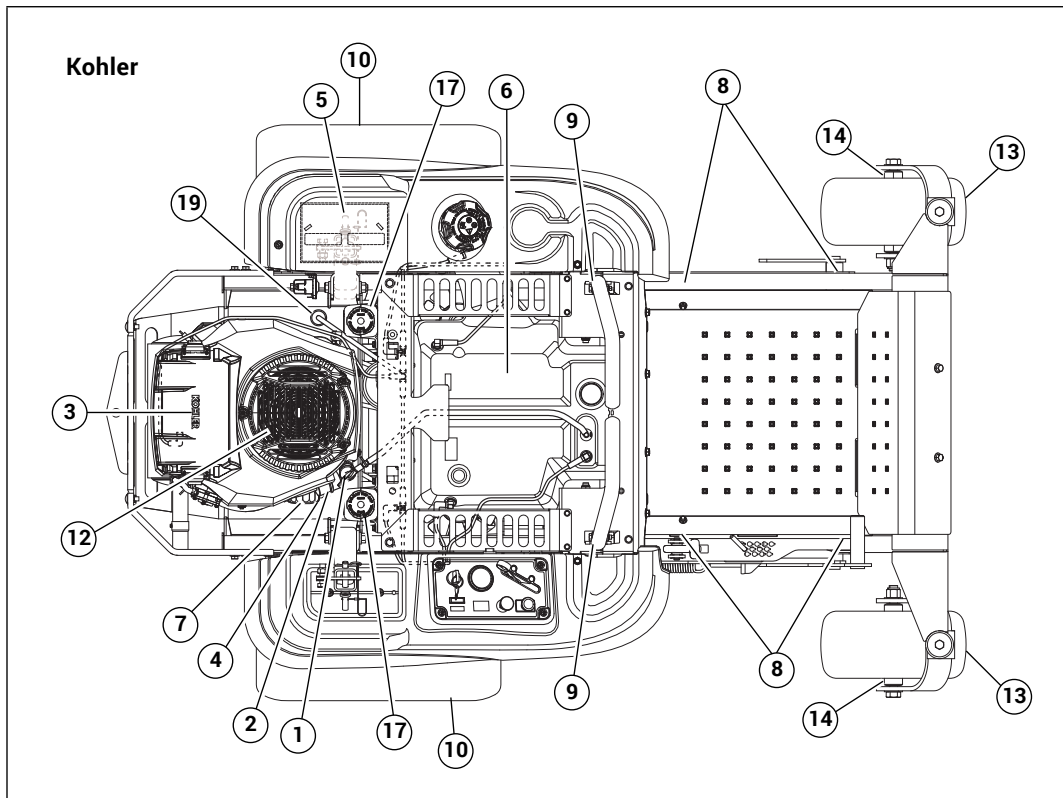

Figure 8-2

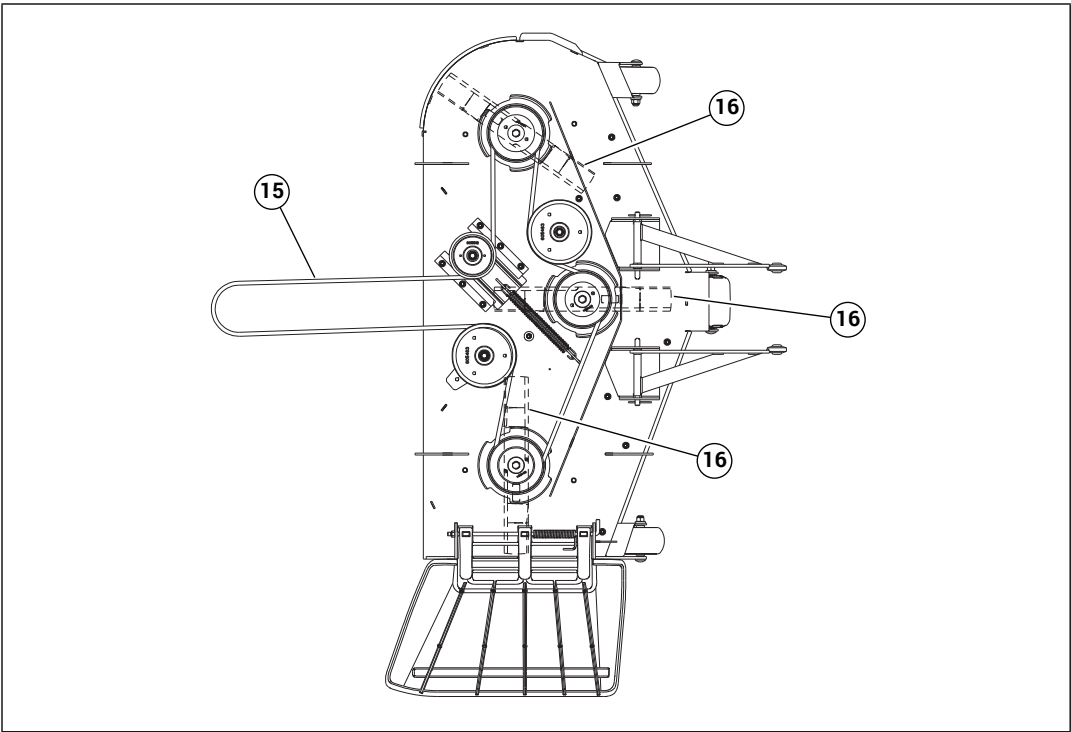

Figure 8-3

- 1. Engine Oil Fill & Dipstick
- 2. Fuel Filter
- 3. Engine Air Cleaner
- 4. Engine Oil Drain Valve
- 5. Battery
- 6. Fuel Tank
- 7. Engine Oil Filter
- 8. Deck Lift Pivot Zerk (4)
- 9. Park Brake Switch (2)
- 10. Drive Tire
- 11. Pump Belt
- 12. Engine Air Intake Screen
- 13. Front Wheel Tires
- 14. Front Wheel Zerks (2)
- 15. Deck Belt
- 16. Blades
- 17. Hydraulic Oil Expansion Tank
- 18. Hydraulic Oil Filter
- 19. Fuel Evaporation System Filter
- 20. Carbon Canister

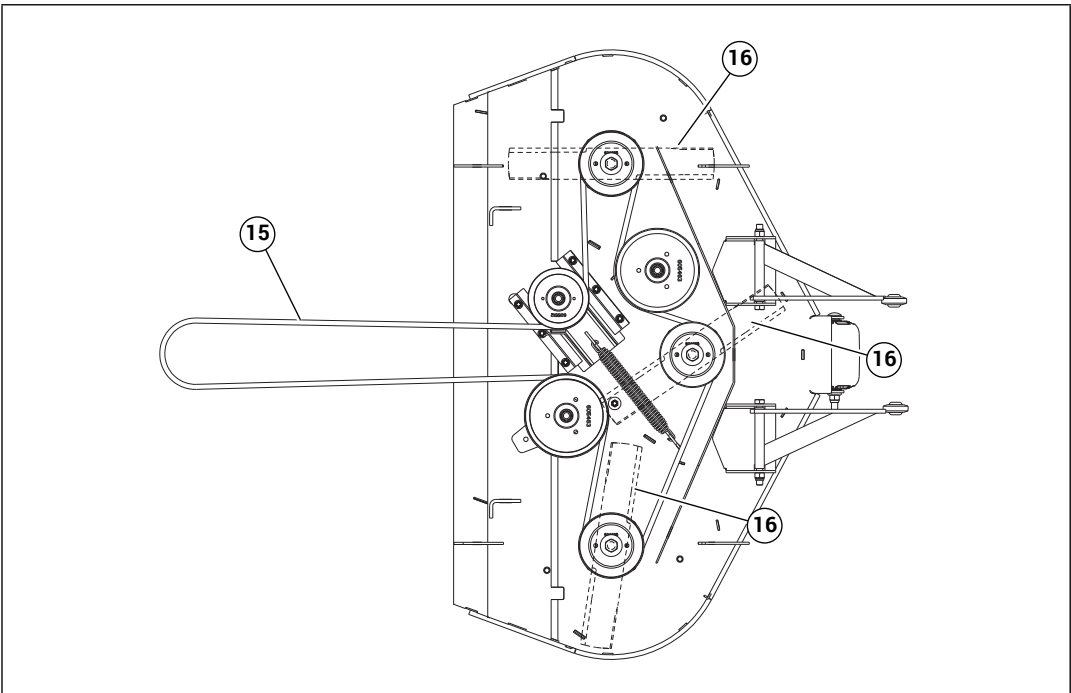

Figure 8-4

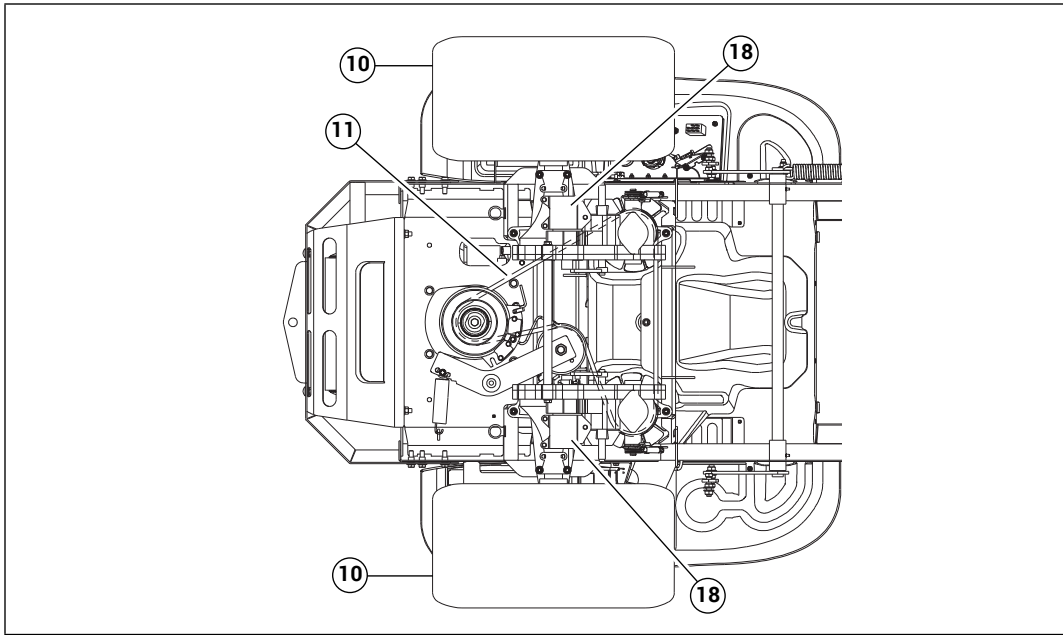

Figure 8-5

1. Engine Oil Fill & Dipstick
2. Fuel Filter
3. Engine Air Cleaner
4. Engine Oil Drain Valve
5. Battery
6. Fuel Tank
7. Engine Oil Filter
8. Deck Lift Pivot Zerk (4)
9. Park Brake Switch (2)
10. Drive Tire
11. Pump Belt
12. Engine Air Intake Screen
13. Front Wheel Tires
14. Front Wheel Zerks (2)
15. Deck Belt
16. Blades
17. Hydraulic Oil Expansion Tank
18. Hydraulic Oil Filter
19. Fuel Evaporation System Filter
20. Carbon Canister

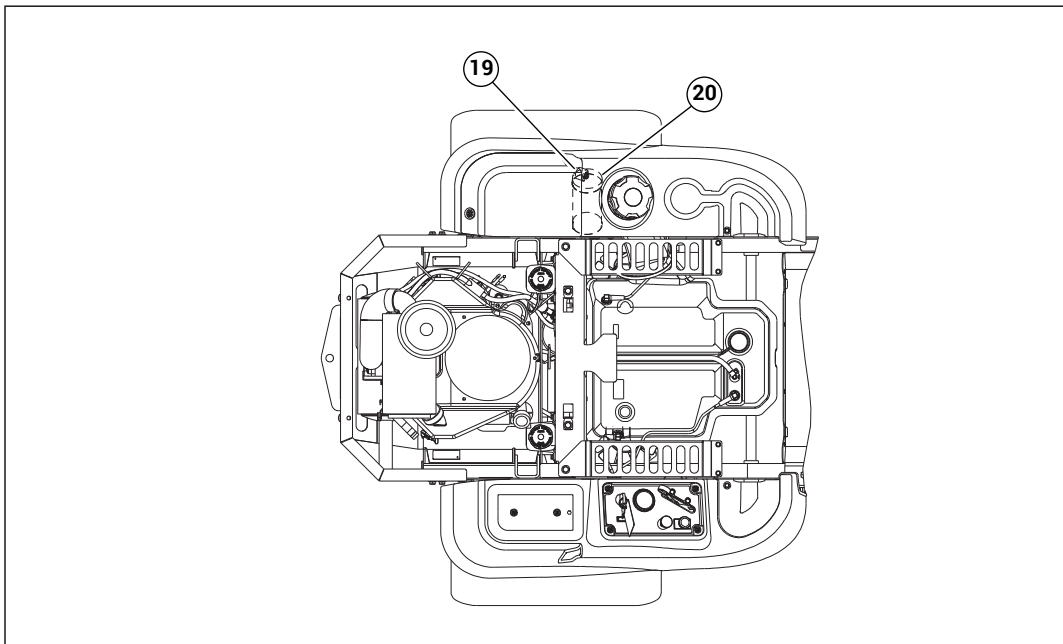

Figure 8-6

TROUBLESHOOTING

SYMPTOMS	PROBABLE CAUSES	SUGGESTED REMEDIES
Starting motor does not crank	Steering control levers not in park brake position or switch not adjusted	Place steering control levers in park brake position or re-adjust switch
	Deck clutch switch engaged	Disengage clutch switch
	Weak or dead battery	Recharge or replace
	Electrical connections are corroded or loose	Check the electrical connections
	Fuse is blown	Check fuses – replace blown fuse
	For additional causes	See engine manual
The engine will not start, starts hard or fails to keep running	No fuel or line plugged	Fill tank or replace line (See <i>Fuel System</i> section for more details)
	Fuel valve is turned off	Open the fuel valve
	There is incorrect fuel in the fuel system	Drain the tank and replace the fuel with the proper type
	There is dirt in the fuel filter	Replace the fuel filter
	Dirt, water or stale fuel in the fuel system	Contact your Dealer
	The choke is not on	Move the choke lever to ON
	Numerous	See engine manual
Engine: Runs with continuous misfiring or engine runs unevenly or erratically	Numerous	See engine manual
Loss of power or system will not operate in either direction	Restrictions in air cleaner	Service air cleaner
	Poor compression	Contact your Dealer
	Steering linkage needs adjustment	Adjust linkage
	Tow valve open	Close tow valve
	The traction drive belt is worn, loose or broken	Install a new traction drive belt
	Air in system	Check filter and fittings
	For additional causes	See engine manual
Air cooled engine overheating	Air intake screen or cleaning fins clogged	Clean screen and fin
	For additional causes	See engine manual
Low engine oil pressure	Low oil level	Add oil
	Oil diluted or too light	Change oil and check for source of contamination
	Failed oil pump	Contact your Dealer
High oil consumption	Numerous	Contact your Dealer
Mower jerky when starting or operates in one direction only	Steering control linkage needs adjustment	Adjust linkage
	Loose steering linkage	Tighten linkage
	Transaxle component faulty	Contact your Dealer

SYMPTOMS	PROBABLE CAUSES	SUGGESTED REMEDIES
Mower creeps when steering control levers are in neutral	Steering linkage needs adjustment	Adjust linkage
Mower circles or veers in one direction	Steering linkage needs adjustment	Adjust linkage
	Loose steering linkage	Tighten linkage
	Tires improperly inflated	Adjust air pressure to 8–12 psi (55–83 KPa)
	Transaxle component faulty	Contact your Dealer
Mower creeps when parking brake engaged	Steering linkage out of adjustment	Adjust steering linkage
	Brakes need adjustment	Adjust parking brakes
There is abnormal vibration	The engine mounting bolts are loose	Tighten the engine mounting bolts
	The engine pulley, idler pulley or blade pulley is loose	Tighten the appropriate pulley
	The engine pulley is damaged	Contact your Dealer
	The cutting blade(s) is/are bent or unbalanced	Install new cutting blade(s)
	A blade mounting bolt is loose	Tighten the blade mounting bolt
	Spindle bearing is worn or loose	Replace or tighten spindle bearing
	A blade spindle mount is bent	Contact your Dealer
Blades do not rotate	The deck drive belt is worn, loose or broken	Install a new deck drive belt
	The deck drive belt is off the pulley	Install the deck drive belt and check for a reason
	Electric clutch is not engaging	Check and/or replace 15 amp fuse. Contact your Dealer
Uneven cutting height	The blade(s) are not sharp	Sharpen the blades
	A cutting blade(s) is/are bent	Install new cutting blade(s)
	The deck is not level	Level the deck per the <i>Deck leveling and height adjustment</i> section of the General Service Manual
	An anti-scalp wheel is not set correctly	Adjust the height of the anti-scalp wheel
	The underside of the deck is dirty	Clean the underside of the deck
	Tires improperly inflated	Adjust air pressure to 8–12 psi (55–83 KPa)
	A blade spindle mount is bent	Contact your Dealer
	Flex Forks® are installed	After initial break-in period, level the deck per the <i>Deck Leveling</i> section of the General Service Manual.

INDEX

	PAGE		PAGE
Avoid Acid Burns	2-4	Maintenance Schedule	8-1
Avoid Fire Hazards	2-2, 2-3	Mower Blade Maintenance	6-2
Belts	4-5, 6-4	Mower Blade Removal	6-3
Blades	6-2	Operate Machine Safely	2-2
Carbon Canister	5-3	Operation Precautions	2-2
Deck Belt Adjustment	6-4	Park Brake Spring Adjustment	4-3
Deck Belt Installation	6-4	Pre-Operation Precautions	2-1
Deck Leveling	6-1	Prepare for Emergencies	2-3
Draining the Engine Oil	5-1	Prevent Battery Explosions	2-3
Engine Oil and Filter	5-1	Purging Procedure	4-7
Engine RPM Settings	5-6	Rear Discharge Deck Belt Routing	6-6
Fluid Changing Procedure	4-6	Safe Servicing Practices	2-1
Fuel & Evaporative System Line Routings	5-4	Service Program	1-1
Fuel Evaporation System Filter	5-4	Side Discharge Deck Belt Routing	6-5
Fuel Handling	2-1	Special Torques	3-1
General Engine Maintenance	5-1	Standard Torques	3-1
General Maintenance Precautions	2-2	Start Engine Safely	2-2
Hydraulic Pump Belt Adjustment	4-5	Steering Adjustments	4-1
Hydraulic System	4-5	Steering Control Lever Neutral Adjustment	4-1
Main Electrical Harness Schematic	7-1, 7-2	Steering Control Lever Stops	4-4
Main Harness to Fuel Gauge Voltage Convertor Schematic	7-3	Tires	4-9
Maintenance Introduction	1-1	Understand Correct Service	2-1
Maintenance Locator Chart	8-2	Understand Machine Operation	2-2
Maintenance Precautions	2-3	Warranty	1-1
		Wear Protective Clothing	2-2

PAGE

PAGE