

Hustler® Parts Manual



HUSTLER®
TURF EQUIPMENT

200 South Ridge Road

Hesston, Kansas

67062



NOTICE OF REQUIREMENT OF SPARK ARRESTER MUFFLER

This equipment may create sparks that can start fires around dry vegetation. California Public Resources Code Section 4442.6 provides that it is unlawful to use or operate an internal combustion engine on any forest-covered, brush-covered, or grass-covered land unless the engine is equipped with a spark arrester maintained in effective working order. A spark arrester is a device constructed of nonflammable materials specifically for the purpose of removing and retaining carbon and other flammable particles over 0.0232 of an inch in size from the exhaust flow of an internal combustion engine that uses hydrocarbon fuels or which is qualified and rated by the United States Forest Service. Other states or federal areas may have similar laws. The Operator Should Contact Local Fire Agencies For Laws or Regulations Relating to Fire Prevention Requirements. **THIS EQUIPMENT DOES NOT HAVE A SPARK ARRESTER AND YOU SHOULD CONTACT YOUR AUTHORIZED DEALER FOR THE PURCHASE OF A SPARK ARRESTER.**

Inspect spark arrester daily; replace every 500 hours or as needed.

The Engine Owner's Manual provides information regarding the U.S. Environmental Protection Agency (EPA) and the California Emission Control Regulation of emission systems, maintenance and warranty.

Keep Engine Owner's Manual with your unit. Should the Engine Owner's Manual become damaged or illegible, replace immediately. Replacements may be ordered per the information found in the Product Information section of the owner's manual.

Federal law and California State law prohibit the following acts or the causing thereof:

1. The removal or rendering inoperative by any person other than for purposes of maintenance, repair, replacement, of any device or element of design incorporated into any equipment for the purposes of emissions control prior to or after its sales or delivery to the ultimate purchaser or while it is in use, or
2. The use of the equipment after such device or element of design has been removed or rendered inoperative by any person.

General Information	1
Frame, Engine Guard & Hitch	
Frame	3-1
Engine Guard & Hitch	3-2
Transmissions, Drive Belt, Steering & Brake	
Transmission Assembly & Drive Belt	4-1
Transmission Service Parts	4-2
Steering & Brake (Multi-Page)	4-3
Steering Cover Assembly	4-4
Steering Box Assembly	4-5
Wheels & Tires	
Wheels & Tires	5-1
Front Wheel Assembly	5-2
Drive Wheel Breakdown	5-3
Engine, Muffler, Clutch & Fuel System	
Engine, Muffler & Clutch	6-1
Engine Service Parts - FX691V	6-2
Fuel System (Multi-Page)	6-3
Fuel Tank Service Parts - 607667	6-4
Fenders, Battery, Instrument Panel & Wire Harness	
Fenders & Battery	7-1
Instrument Panel & Wire Harness	7-2
Deck, Deck Belt, Blades & Deck Lift	
Service Deck	8-1
Deck Pulleys & Spindles	8-2
Spindle Service Parts - 607208	8-3
Deck Belt, Discharge Chute, Pulley Covers & Blades	8-4
Deck Lift & Deck Mounting Hardware (Multi-Page)	8-5
Seat & ROPS	
Seat, Footrest & Floor Pan (Multi-Page)	9-1
Seat Service Parts	9-2
ROPS	9-3

General Information

Note: When ordering parts, you must use the part number as shown for each part, not the index number. Always give the model and serial number to your parts and service representative.

Note: Items sold in bulk such as seals and hoses are sold by the foot.

Using This Manual

This manual is part of a service package for the Hustler® mowers. Use of this manual in conjunction with other Hustler® mower and component manuals will provide the information necessary to service and maintain Hustler® mowers.

This Parts Manual provides a complete parts listing for the unit. Use this manual when ordering parts. Illustrations used were current at the time of printing, but subsequent production changes may cause your machine to vary slightly in detail. Excel Industries, Inc. reserves the right to redesign and change the machine as deemed necessary, without notification. If a change has been made to your machine which is not reflected in this parts manual, see your authorized dealer for current information and parts.

The Service Manual is a service guide for use by Service Technicians. It provides the necessary information needed to perform normal maintenance requirements on these units.

The Operator's Manual provides fundamental operational information and operational safety that is needed when operating the mower.

The component manuals are furnished by the various manufacturers to be used for the troubleshooting and servicing of their products.

Hardware Description Codes & Abbreviations

The following codes are used throughout this parts manual. Refer to this list when ordering parts.

ABBREVIATION	DESCRIPTION	ABBREVIATION	DESCRIPTION
CB	CARRIAGE BOLT	MB	MACHINE BUSHING
CE	CLEVIS PIN	MS	MACHINE SCREW
CN	CLIP NUT	NT	NUT
CP	COTTER PIN	SC	SELF TAPPING CAP SCREW
CS	CAP SCREW	SH	SOCKET HEAD
CW	CUP WASHER	SB	SHOULDER BOLT
FDRW	FENDER WASHER	SS	SET SCREW
FW	FLAT WASHER	OD	OUTSIDE DIAMETER
HX	HEX HEAD	ID	INSIDE DIAMETER
LW	LOCK WASHER	WN	WELD NUT

Standard Torques

The following chart lists the standard torque values for the threaded fasteners found in this manual. Torque all cap screws, nuts and set screws to these values unless a different torque is shown in the Notes section next to the fastener.

SIZE	FT-LBS	N•M	SIZE	FT-LBS	N•M
.250	8.2	11.1	M3	1	1.3
.312	17	23	M4	2.2	3
.375	30	40	M5	4.5	6.1
.438	48	65	M6	7.7	10.4
.500	73	99	M8	18.5	25
.562	105	143	M10	37	50
.625	145	200	M12	64	87
.750	260	350	M14	80	108.5
.875	420	565	M16	160	215
1.00	625	850	M20	320	435
			M24	555	750

This page intentionally left blank

Frame

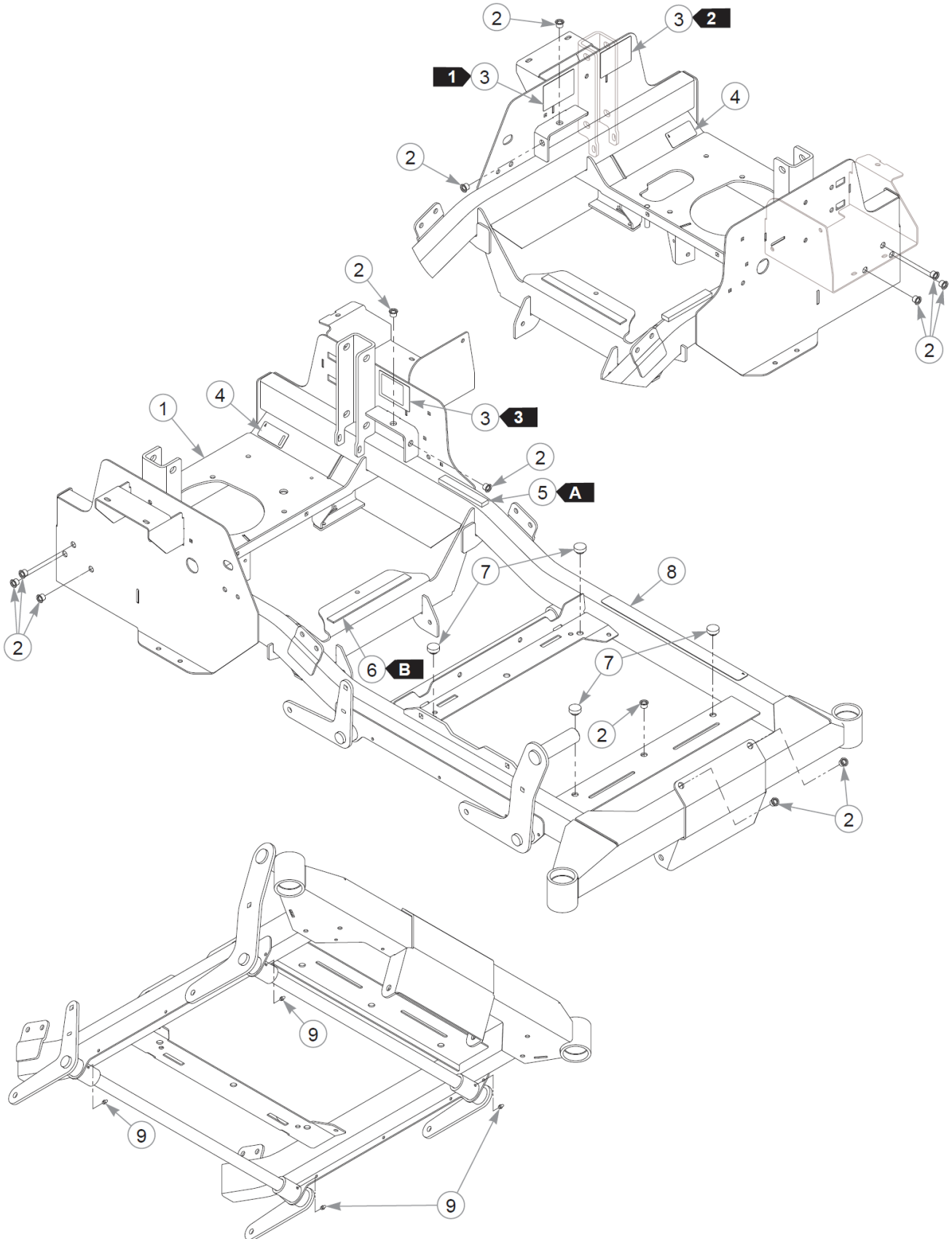

Frame

Item	Part No.	Qty	Name
1	554675	1	SVC FRAME
2	808493	13	RIVET NUT, 3/8-16 THREA
3	N/A	3	SERIAL NUMBER / SPEC DECAL
4	602041	2	DECAL, HOT
5	713198	5"	SEAL 3/8x3/4 SOLD BY FT
6	033035	9"	WEATHERSTRIP .12X.75
7	781880	4	BUMPER, .500x 1.00x .31
8	601993	1	DECAL, SAFE OPERATION
9	015495	4	GREASE FITTING STRAIGHT

Comments for Page: Frame

1. Serial number decal. In the event the serial number decal becomes damaged or illegible, please contact your dealer to order a replacement.
2. EPA compliance decal.
3. Patent numbers decal.
4. The frame includes the decals and hardware.

SEAL/WEATHERSTRIP LENGTHS

A: 5.0"

B: 9.0"

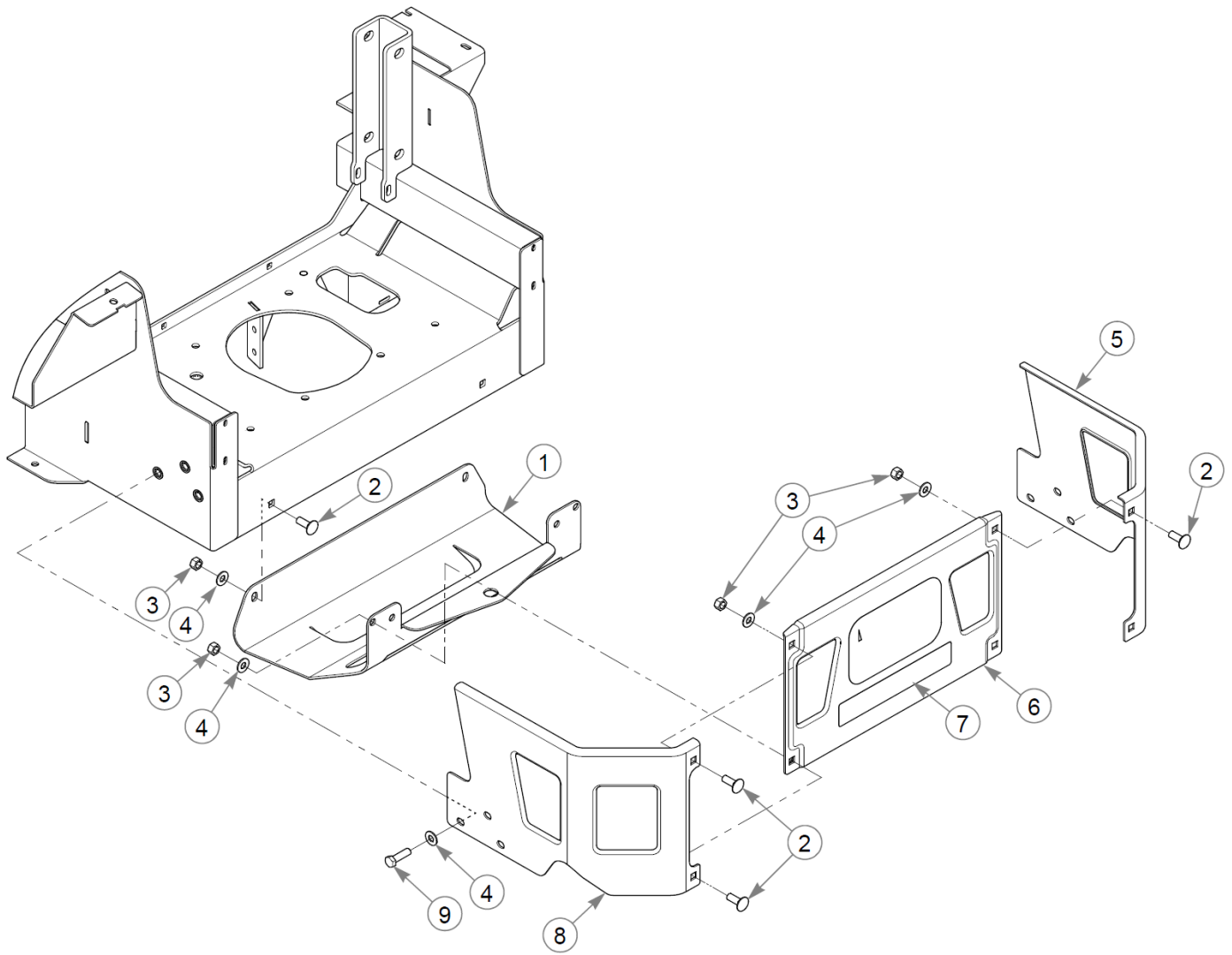

Engine Guard & Hitch

Item	Part No.	Qty	Name
1	119977	1	HITCH PLATE
2	025395	6	CB .375-16X 1.00 G5 ZN
3	054502	6	NT .375-16HXG5
4	767954	12	FW 0.379X.82X.06 HD ZN
5	121134	1	GUARD, RH
6	553123	1	SVC PART, STAMPED BUMPER
7	604770	1	DECAL, "H" LOGO
8	121133	1	GUARD, LH
9	052860	6	CS .375-16X1.25 HX G5 ZN

Comments for Page: Engine Guard & Hitch

1. The center guard includes the decal.

Transmission Assembly & Drive Belt

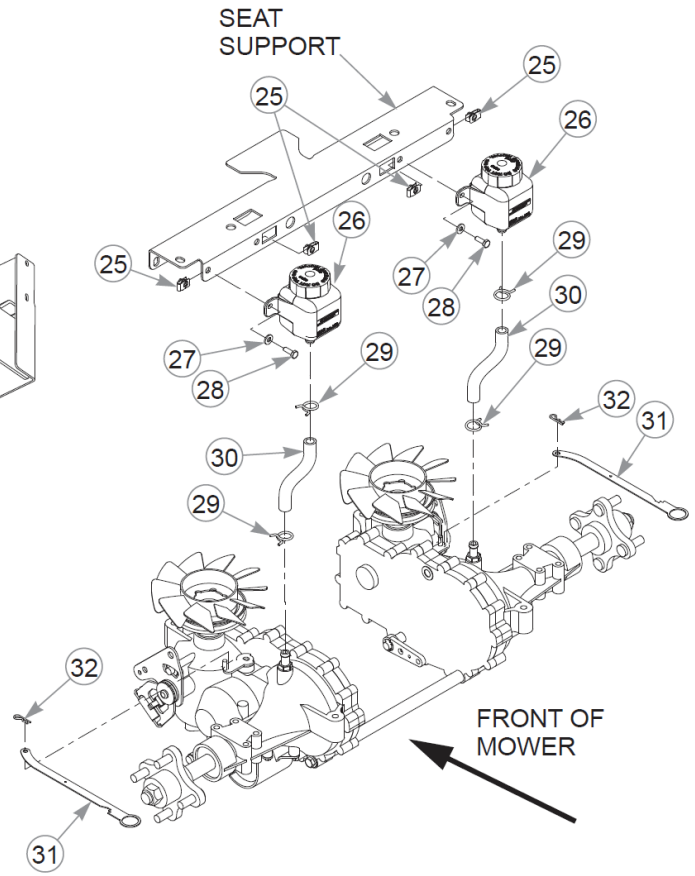
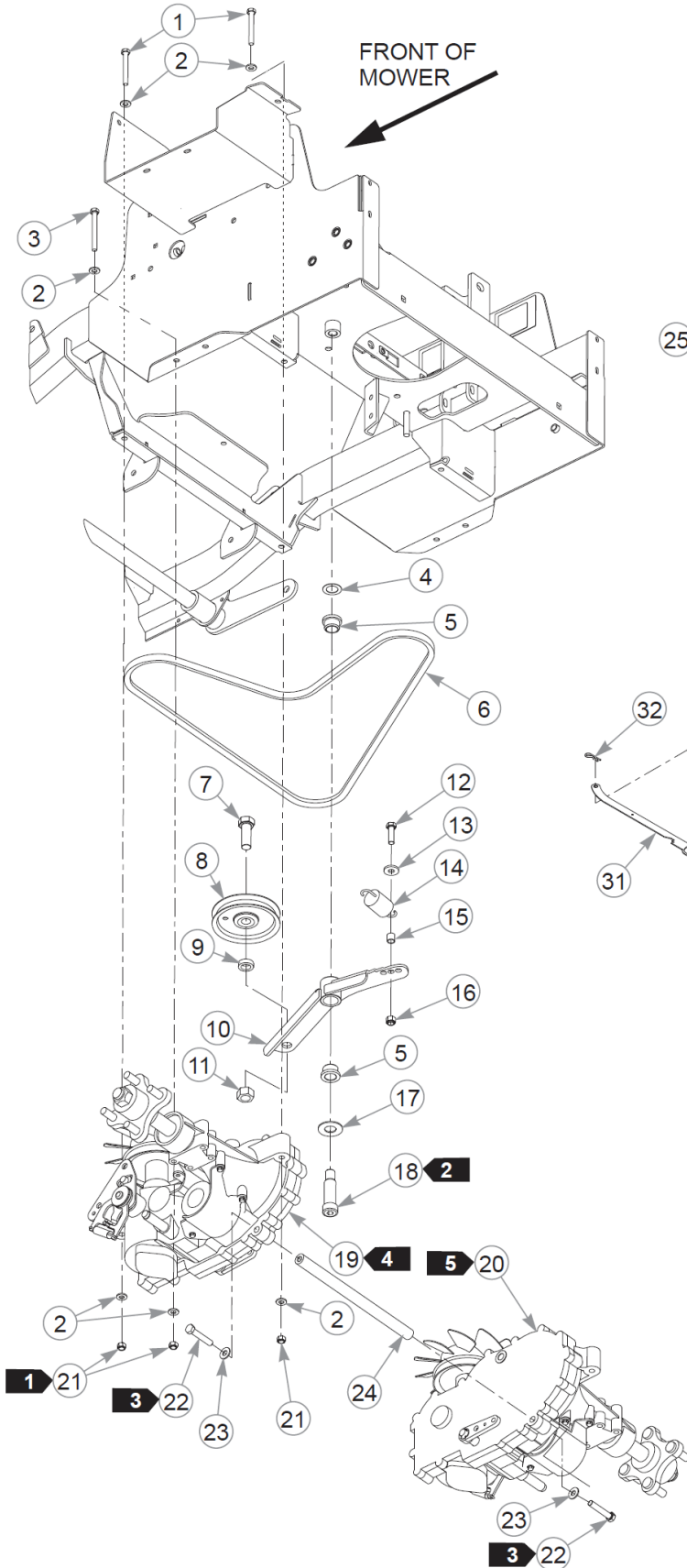

Transmission Assembly & Drive Belt

Item	Part No.	Qty	Name
1	710087	4	CS .312-18X2.500HXG5
2	768523	16	FW 0.343SAE
3	043067	4	CS .312-18X3.000HXG5
4	704791	1	FW .781X1.25X.02 ZN
5	781153	2	BUSHING, UHMW
6	605468	1	DRIVE BELT
7	025007	1	CS .62511X1.750HXG5
8	607525	1	PULLEY, IDLER
9	600296	1	SPACER, DECK IDLER
10	122722	1	KIT, TENSION ARM
11	016972	1	NT .625-11 HX G5 ZN
12	052860	1	CS .375-16X1.25 HX G5 ZN
13	712919	1	FW 0.406X1.00X.12 HD ZN
14	036384	1	SPRING 1/4 COIL PL 1.23
15	605481	1	BUSHING
16	086660	1	NT .375-16NLG8
17	025296	1	FW .760X1.63X0.08 ZN
18	601084	1	SB .750X 2.000 SH.625-11
19	605500	1	ZT3400, 21.04:1
20	605501	1	ZT3400, 21.04:1
21	058776	8	NT .312-18NLG5
22	608241	2	CS .375-16X2.250HXG8
23	712919	2	FW 0.406X1.00X.12 HD ZN
24	600987	1	ZT SPACER TUBE
25	601982	4	CN .250-20X .150 MAX THK
26	605217	2	RESERVOIR, SINGLE FTNG
Not Shown	600767	2	CAP, OVERFLOW TANK
27	768515	4	FW 0.281SAE
28	055939	4	CS .250-20X0.75 HX G5 ZN
29	601001	4	SPRING CLAMP, .75" DIA
30	605218	2	OVERFLOW HOSE, FST
31	120126	2	LINK, TOW VALVE
32	706549	2	HP0.080X1.190

Comments for Page: Transmission Assembly & Drive Belt

Transmission Assembly & Drive Belt

1. Torque to 17 ft-lbs.
2. Torque to 100 ft-lbs.
3. Torque to 30 ft-lbs.
4. Left side transmission.
5. Right side transmission.
6. P/N 605217 RESERVOIR includes 600767 CAP.

This page intentionally left blank

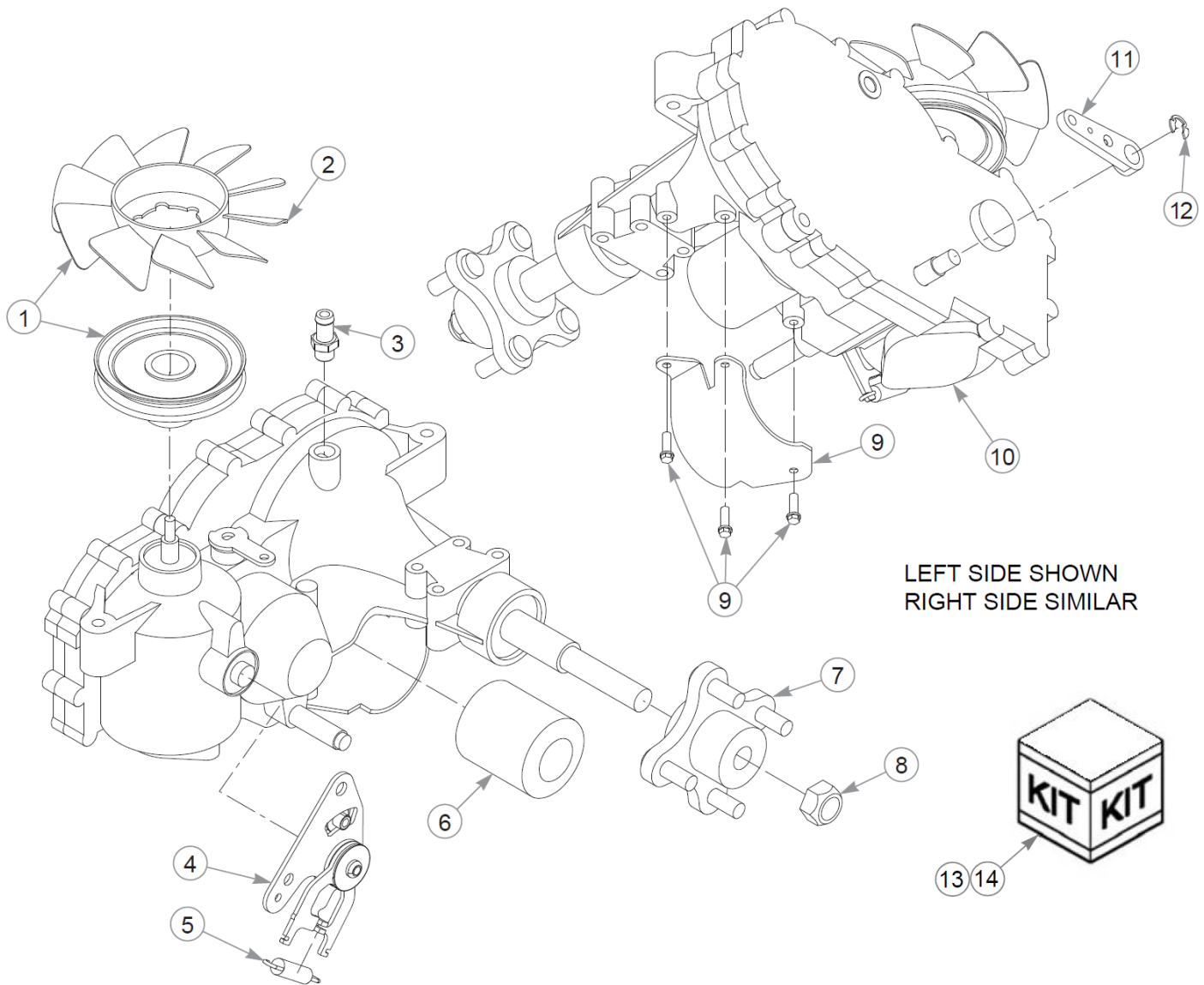

Transmission Service Parts

Item	Part No.	Qty	Name
1	603866	1	FAN/PULLEY KIT
2	607728	1	FAN - 7.0" (10 BLADE)
3	605608	1	FITTING, TRANSMISSION
4	605778	1	RTN, LEFT
Not Shown	605779	1	RTN, RIGHT
5	604903	1	HG RTN SPRING
6	600976	1	HYDRAULIC OIL FILTER
7	601433	1	KIT, HUB 4 BOLT
<p>Comments for Part Num. 601433</p> <p>CUSTOMER SERVICE NOTE: Lug Studs are not sold separately.</p>			
8	788877	1	NUT, H-G ZT HUB
9	600975	1	GUARD, TRANS FILTER
Not Shown	600974	1	GUARD, TRANS FILTER
10	603572	1	COVER, ZT3100 CHRGR PUMP
11	601221	1	ZT2800 BRAKE ARM - 2007
12	600972	1	CLIP, RETAINING
13	606830	1	OIL RETENSION KIT,
14	607200	1	SEAL KIT 72994 HYDRO-G
15	603223	1	O-RING, ZT28/3100 CHARGE

Comments for Page: Transmission Service Parts

1. The hub kit (601433) includes the nut.
2. The filter guard kits and the charge cover kit include bolts.
3. The left and right returns (605778 & 605779) include springs.

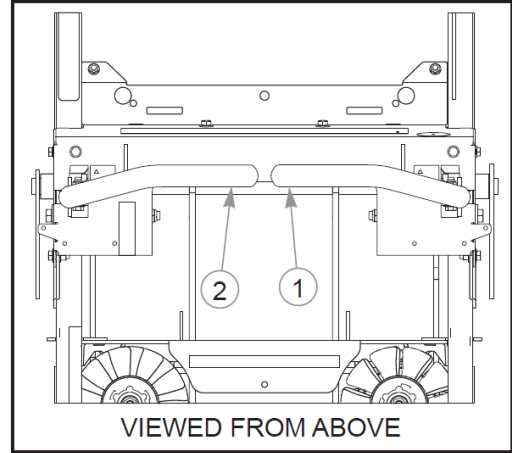
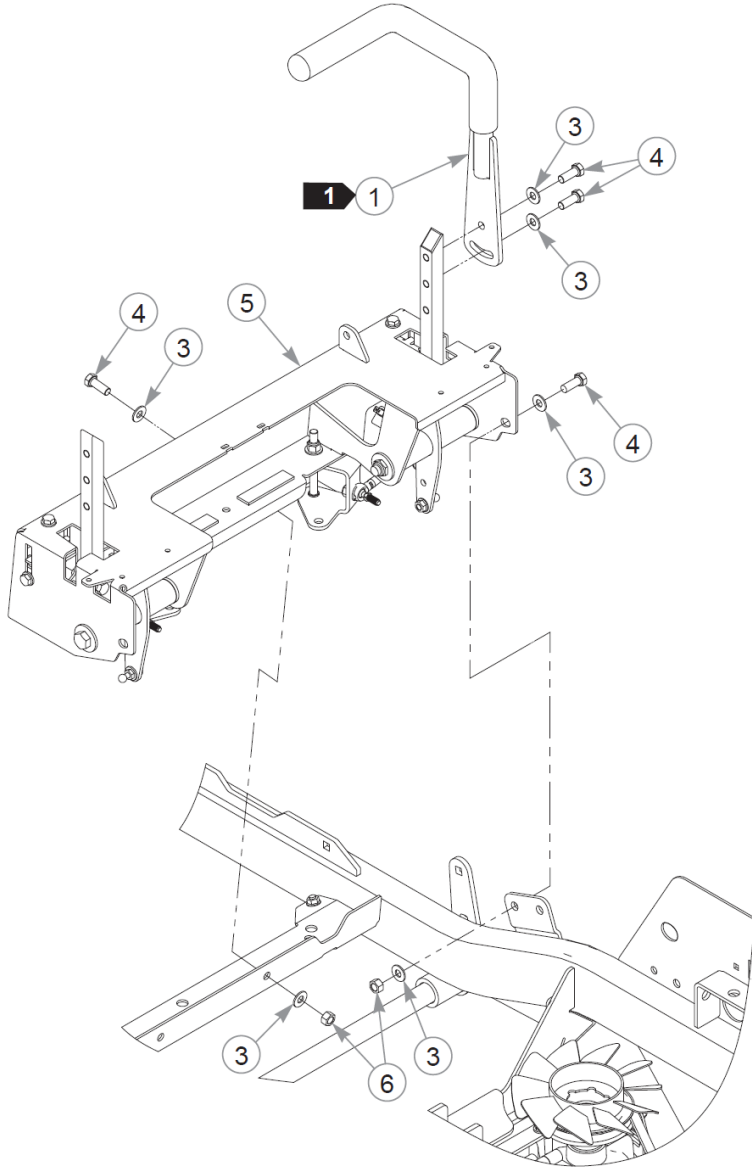

RIGHT SIDE SHOWN
LEFT SIDE SIMILAR

FRONT OF MOWER

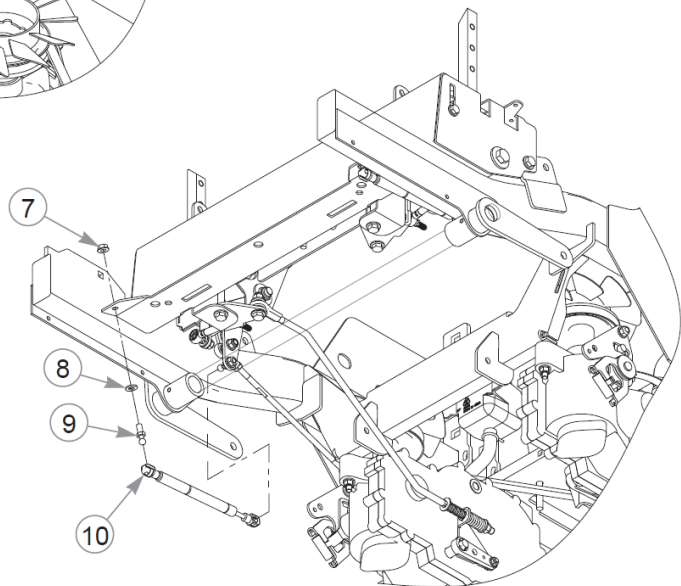

This page intentionally left blank

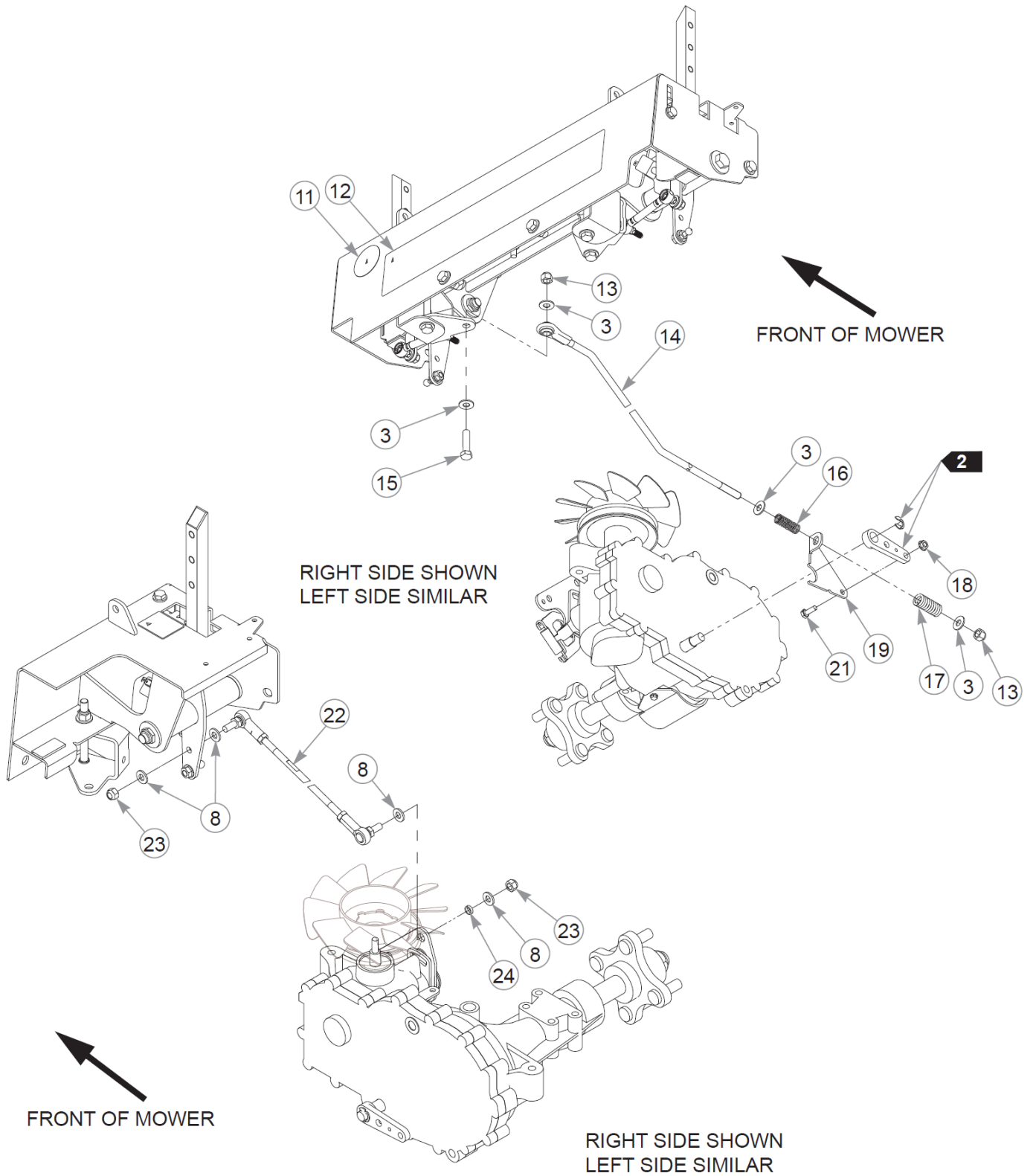

Steering & Brake (Multi-Page)

Item	Part No.	Qty	Name
1	605383	1	STEERING BAR W/A, RH
Not Shown	781260	1	GRIP, STEERING BAR
2	605384	1	STEERING BAR W/A, LH
Not Shown	781260	1	GRIP, STEERING BAR
3	767954	20	FW 0.379X.82X.06 HD ZN
4	036244	8	CS .375-16X1.00 HX G5 ZN
5	N/A	1	REFER TO "STEERING COVER ASSEMBLY"
6	054502	4	NT .375-16HXG5
7	016832	2	NT .312-18FLKG5
8	768523	10	FW 0.343SAE
9	781922	2	BALL STUD
10	603983	2	DAMPER
11	608127	1	DECAL, USA, F&D
12	608097	1	DECAL, FASTRAK SDX
13	086660	4	NT .375-16NLG8
14	605145	2	BRAKE ROD ASSEMBLY
15	080655	2	CS .375-16X1.500HXG5
16	601131	2	SPRING, BRAKE ARM RET.
17	601051	2	OVERTRAVEL SPRING
18	016816	2	NT .250-20FLKG5
19	120671	1	BRAKE SPRING LINK, RS
20	120672	1	BRAKE SPRING LINK, LS
21	055939	2	CS .250-20X0.75 HX G5 ZN
22	600981	2	PUMP ROD ASSEMBLY
23	023655	4	NT 0.312-24 NL G8
24	604456	2	SPACER, PUMP ARM

Comments for Page: Steering & Brake (Multi-Page)

1. The steering arms include the grips.
2. Part of the transmission.

Steering Cover Assembly

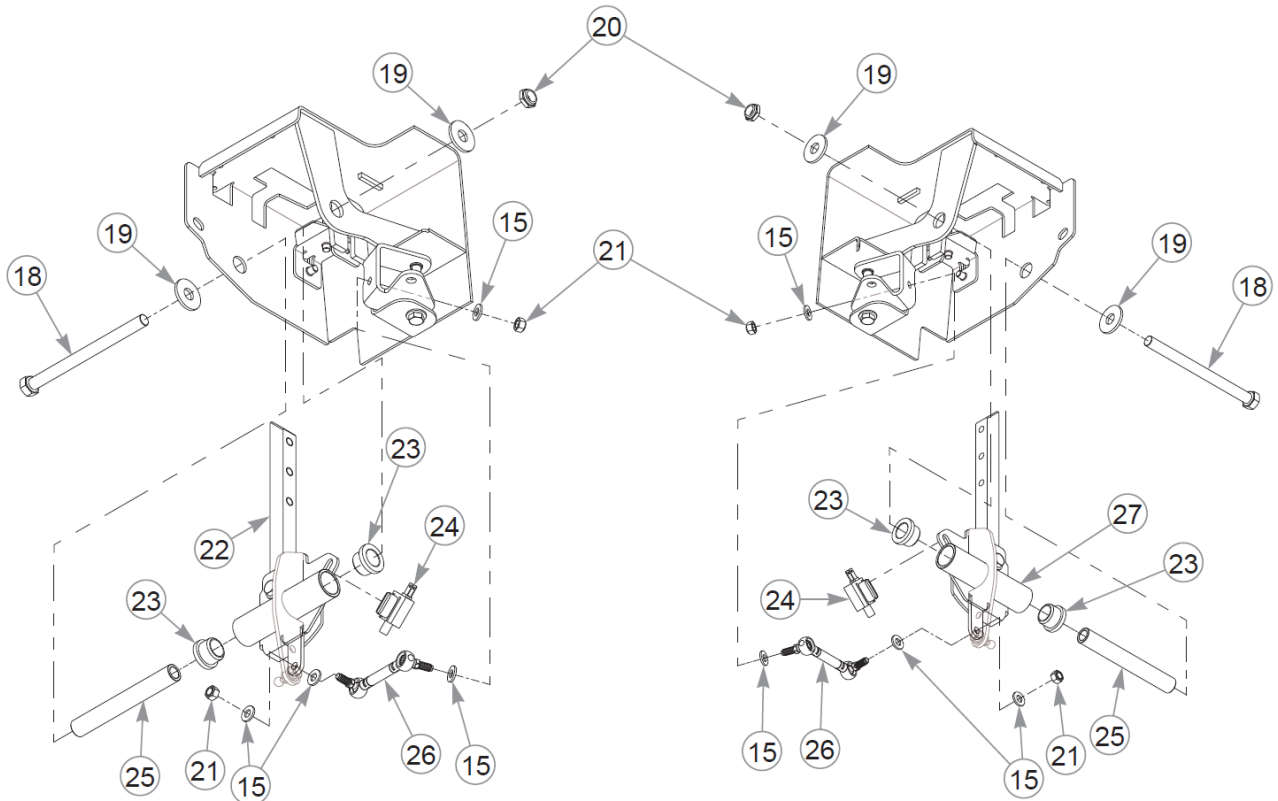
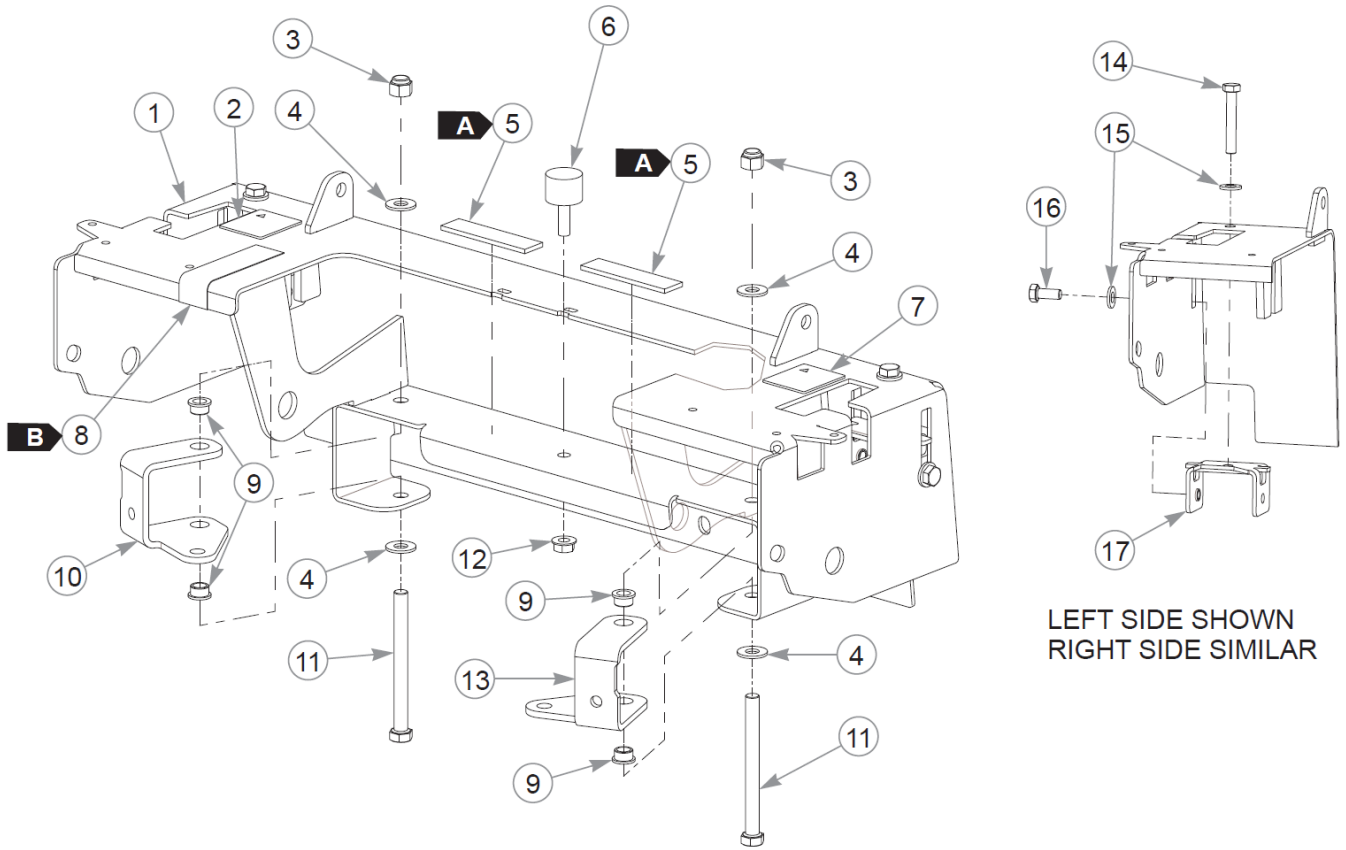

Steering Cover Assembly

Item	Part No.	Qty	Name
1	554690	1	SVC STEERING COVER
2	785139	1	DECAL, STEERING L.S.
3	086660	2	NT .375-16NLG8
4	767954	4	FW 0.379X.82X.06 HD ZN
5	033035	6"	WEATHERSTRIP .12X.75
6	605542	1	ISOLATOR
7	785220	1	DECAL, STEERING R.S.
8	607286	4"	PROTECTIVE TAPE
9	765339	4	BUSHING,IGUS#0608 (FS)
10	124352-1	1	BRAKE BELL CRANK, LS
11	725796	2	CS .375-16X4.000HXG5
12	016832	1	NT .312-18FLKG5
13	124353-1	1	BRAKE BELL CRANK, RS
14	064345	2	CS .312-18X2.000HXG5
15	768523	12	FW 0.343SAE
16	034280	2	CS .312-18X0.750HXG5
17	605518	2	STOP, STEERING
18	042630	2	CS .500-13X6.500HXG5
19	712976	4	FW 0.531X1.38X.12 ZN
20	707398	2	NT .500-13 JAM NY LK
21	058776	4	NT .312-18NLG5
22	N/A	1	REFER TO "STEERING BOX ASSEMBLY"
23	608000	4	BUSHING
24	601087	2	SWITCH, PLUNGER N.O.
25	119811	2	SPACER, STEERING
26	604179	2	BRAKE LINK
27	N/A	1	REFER TO "STEERING BOX ASSEMBLY"

Comments for Page: Steering Cover Assembly

1. The steering cover includes the decals.

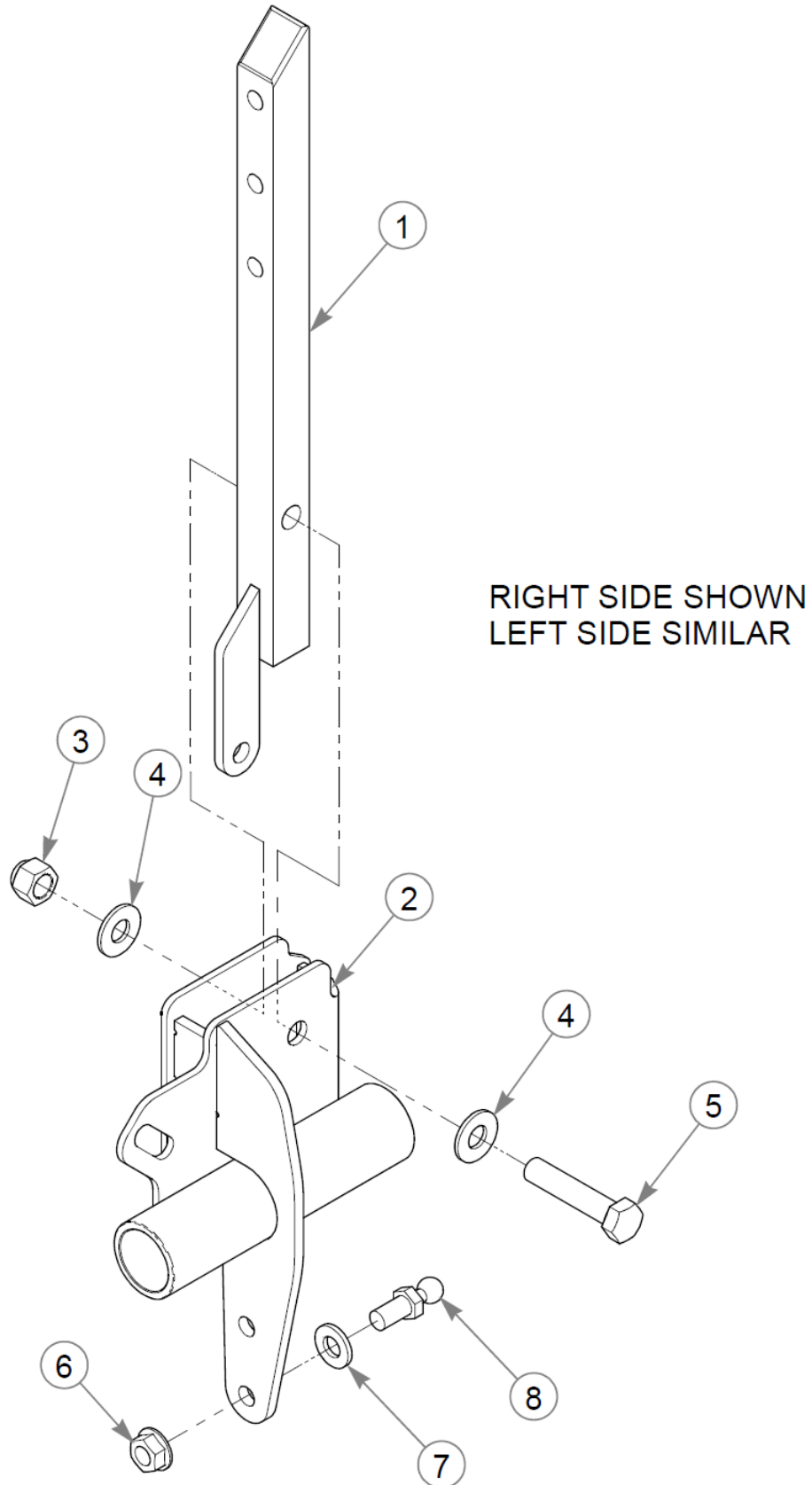

Steering Box Assembly

Item	Part No.	Qty	Name
1	119807	1	STEER LEVER W/A
2	119750	1	STEER PIVOT W/A, RS
Not Shown	119749	1	STEER PIVOT W/A, LS
3	086660	1	NT .375-16NLG8
4	767954	2	FW 0.379X.82X.06 HD ZN
5	705178	1	CS .375-16X1.750HXG5
6	016832	1	NT .312-18FLKG5
7	768523	1	FW 0.343SAE
8	781922	1	BALL STUD

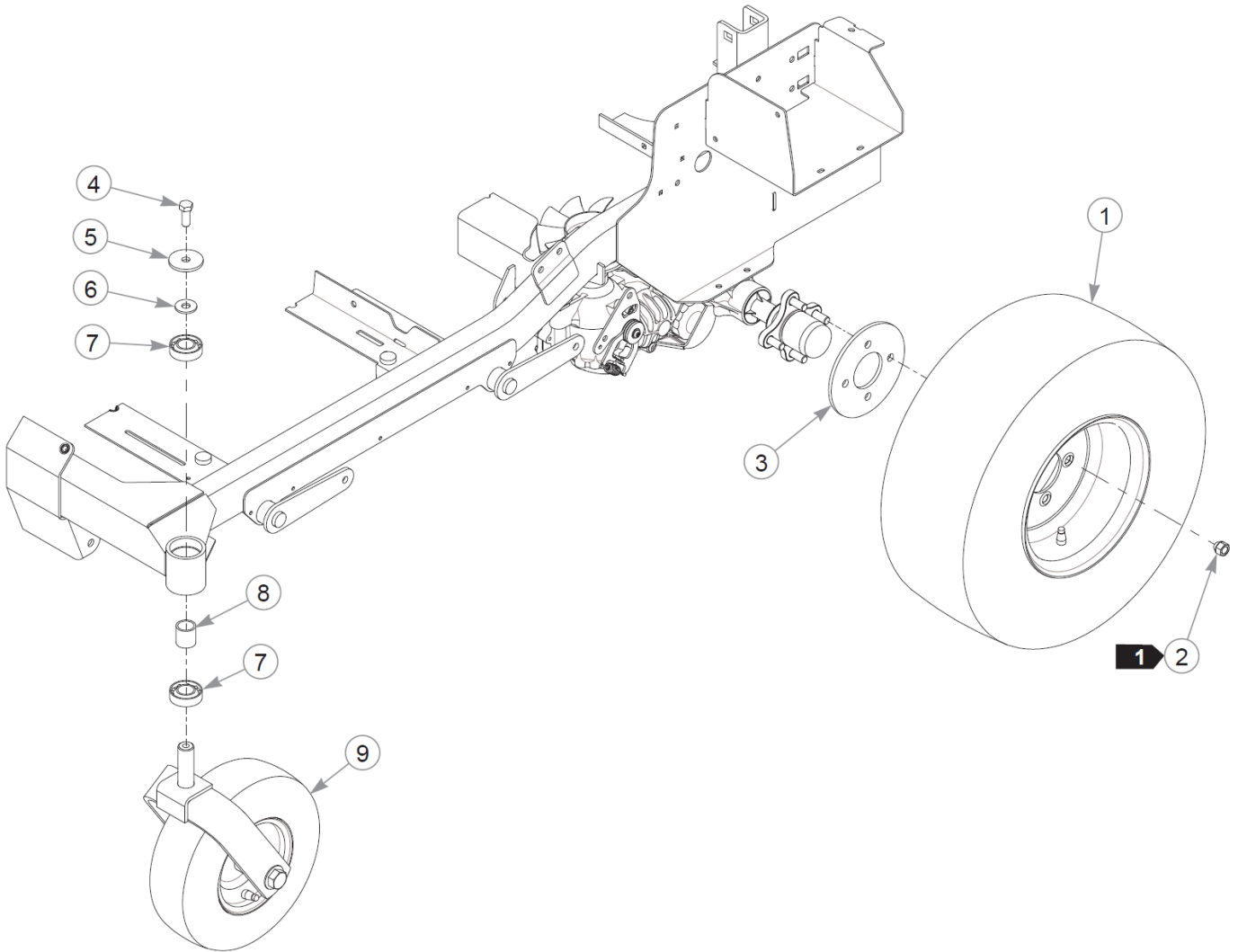

Wheels & Tires

Item	Part No.	Qty	Name
1	607817	2	TIR/WHL 23X9.50-10 BLK
2	061077	8	WHEEL NUT
3	111875-1	2	BACKUP PLATE, WHEEL
4	705954	2	CS .500-13X1.25 HX G5 ZN
5	344267	2	FW .510X2.15X.19 ZN
6	712976	2	FW 0.531X1.38X.12 ZN
7	784223	4	BEARING
8	784603	2	SPACER
9	N/A	2	REFER TO "FRONT WHEEL ASSEMBLY"

Comments for Page: Wheels & Tires

1. Torque to 65–75 ft-lbs.

Front Wheel Assembly

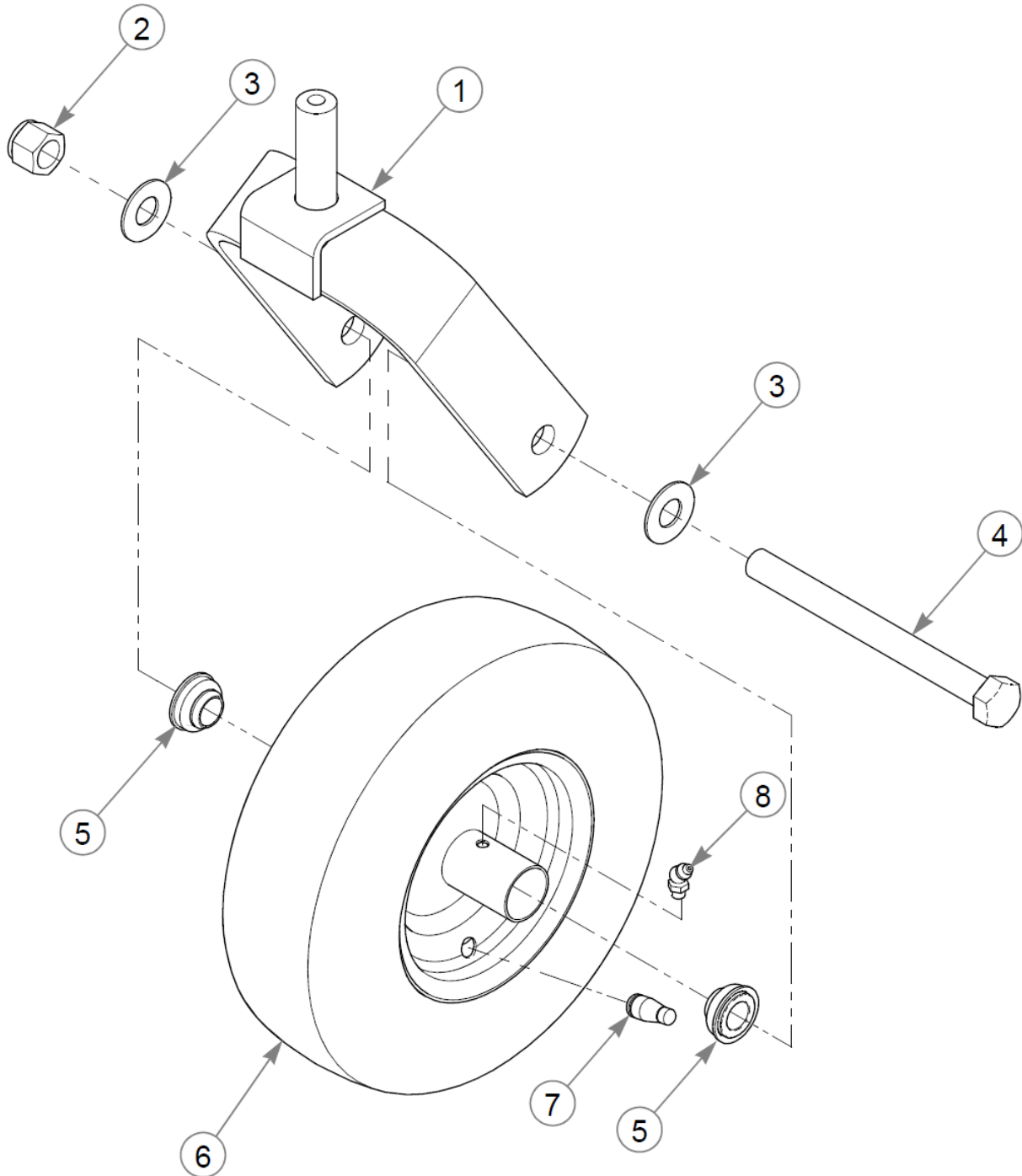

Front Wheel Assembly

Item	Part No.	Qty	Name
1	366625	1	FORK W/A
2	061101	1	NT .750-10 HX ZN NL GR B
3	025296	2	FW .760X1.63X0.08 ZN
4	786731	1	CS .750-10X8.000HXG5
5	786103	2	WHEEL BEARING
6	605049	1	TIR/WHL 13X5.00-6 BLK
7	019521	1	TIRE VALVE TR-412 GOODY
8	606126	1	GREASE FITTING, M8X1.0

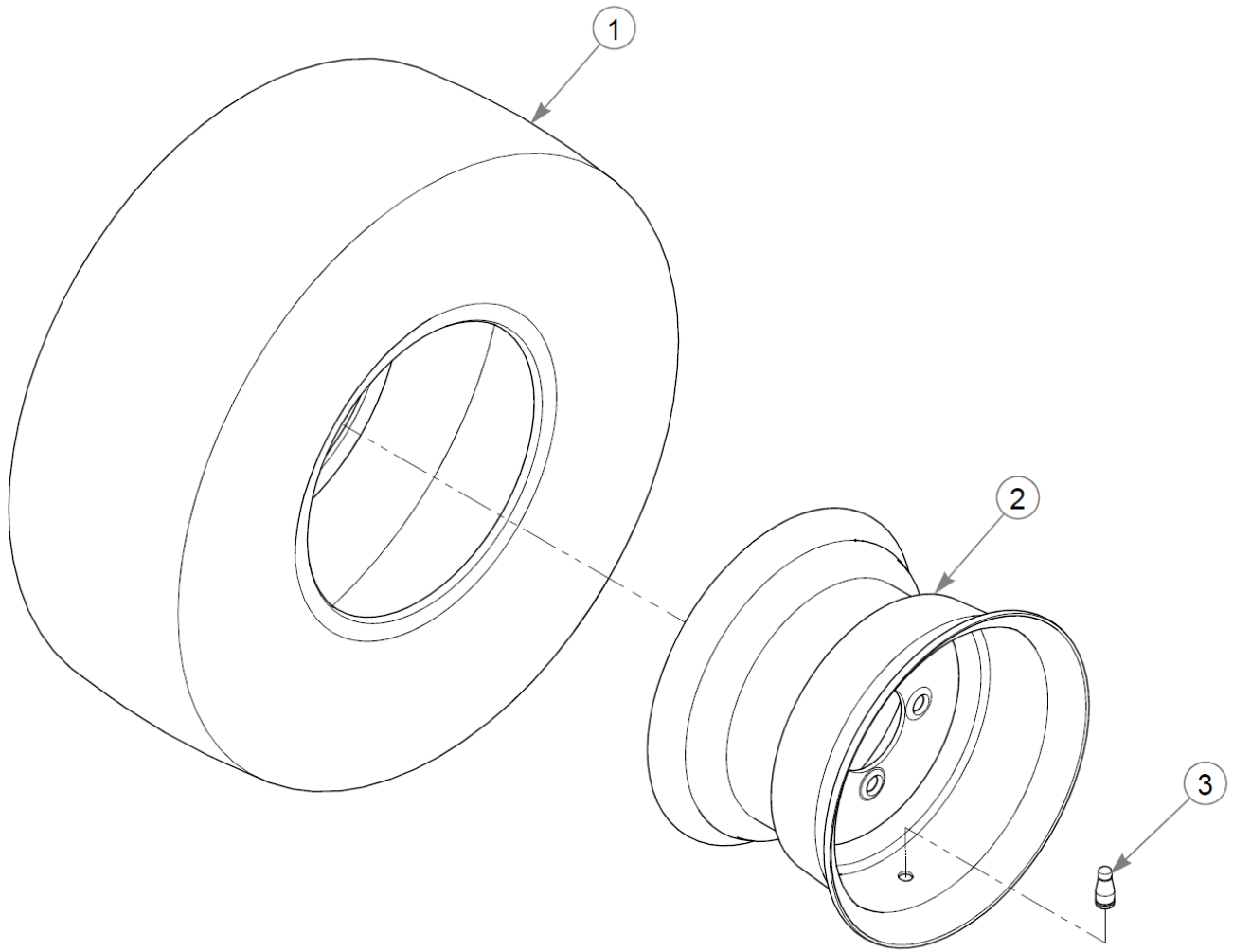

Drive Wheel Breakdown

Item	Part No.	Qty	Name
1	607801	1	TIR 23X9.50-10 B4R BGBT
2	605151	1	WHL 10X7.00 4X4.0 BLK
3	019521	1	TIRE VALVE TR-412 GOODY

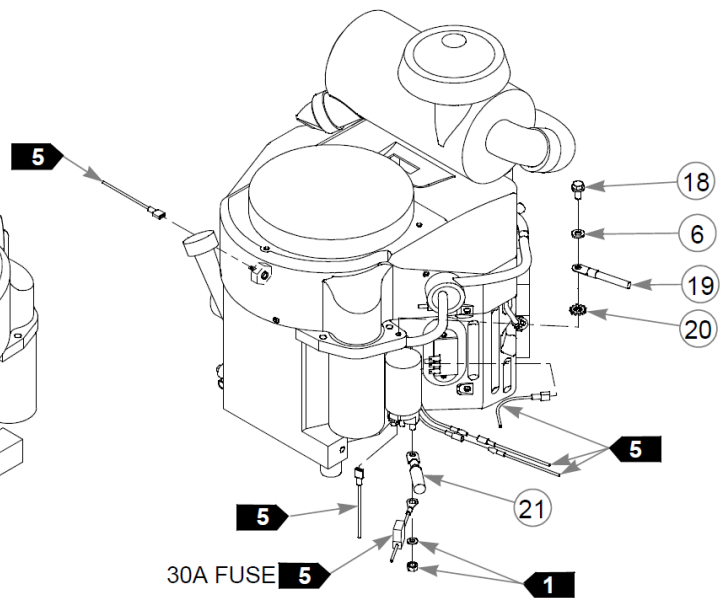
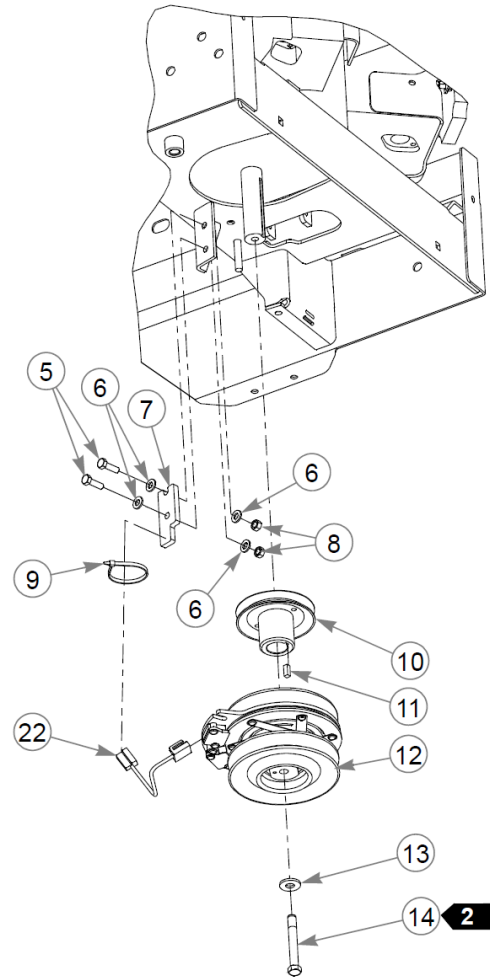
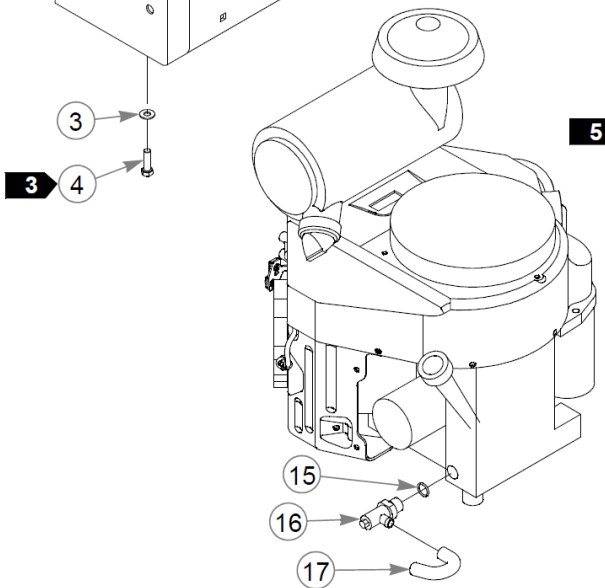
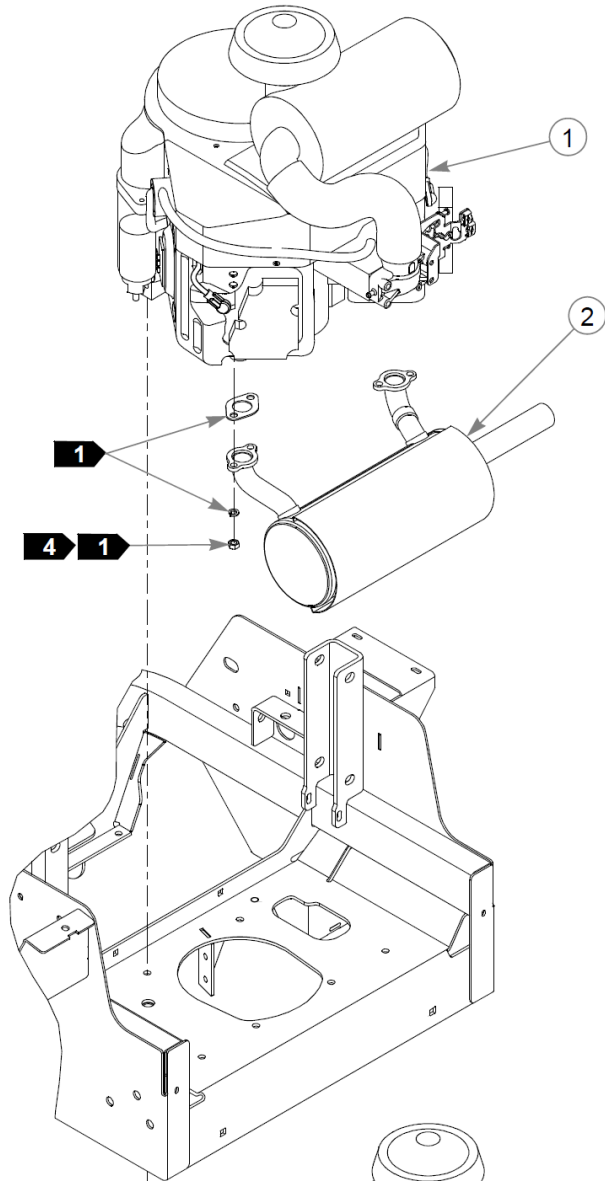

Engine, Muffler & Clutch

Item	Part No.	Qty	Name
1		1	KAWASAKI FX691V ENGINE
2	604250	1	MUFFLER
3	767954	4	FW 0.379X.82X.06 HD ZN
4	602580	4	CS .375-16X1.25HXG8ZYP85
5	036236	2	CS .312-18X1.000HXG5
6	768523	5	FW 0.343SAE
7	113946	1	CLUTCH ANCHOR
8	034272	2	NT .312-18HXG5
9	000331	4	WIRE TIE, SMALL/SHORT
10	605490	1	PULLEY, ENG 4.58OP
11	712372	1	KEY 1/4 SQ X 0.66 LG(FS)
12	121809K	1	CLUTCH KIT
13	602680	1	FW .453X1.12X.12 HRD ZN
14	601834	1	CS .437-20X3.25 HXG5 P85
15	604369	1	O-RING
16	604350	1	VALVE, OIL DRAIN
17	605317	1	HOSE, OIL DRAIN
18	720516	1	CS M8-1.25X16HX FL10.9
19	601841	1	BATTERY CABLE, NEG.
20	029876	1	LW .312 INTEXT ZN
21	785063	1	BATTERY CABLE, POSITIVE
22	791251	1	HARNES, CLUTCH PIGTAIL

Comments for Part Num. 791251

Pigtail was updated with epoxy to hold the wires steady. The wire sheath was also updated to a more flexible material.

Comments for Page: Engine, Muffler & Clutch

1. Supplied with the engine.
2. Torque to 45–48 ft-lbs.
3. Torque to 30–35 ft-lbs.
4. Torque to 17 ft-lbs.
5. Part of the wire harness.

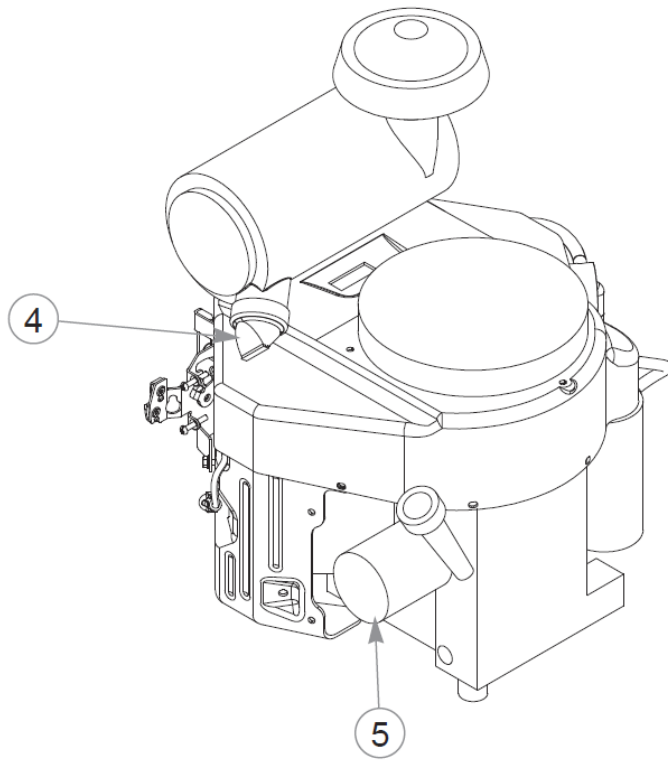
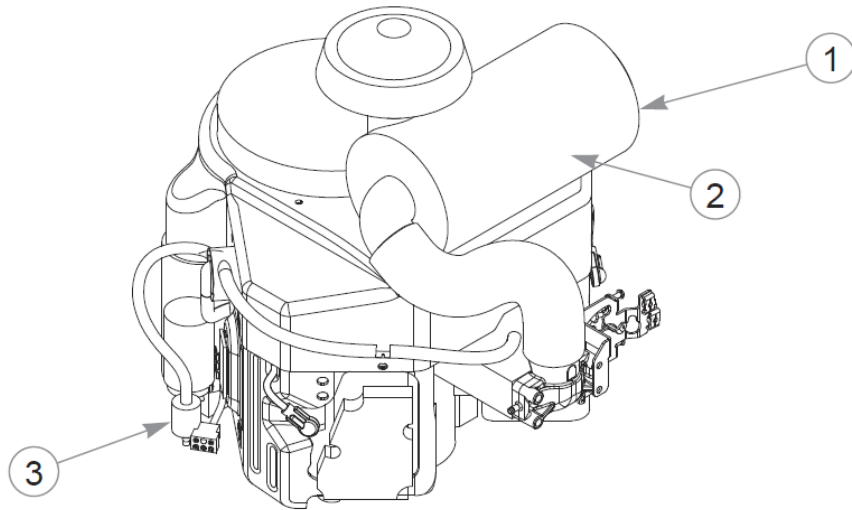

Engine Service Parts - FX691V

Item	Part No.	Qty	Name
1	785261	1	AIR FILTER - MAIN
2	785279	1	AIR FILTER - SAFETY
3	068478	1	FUEL FILTER - IN LINE
4	763318	1	VALVE, VACUATOR
5	602581	1	ENGINE OIL FILTER

Comments for Page: Engine Service Parts - FX691V

1. 602581 is used on FX691V & FX730V engines.
2. 603138 is used on FX850V engine.

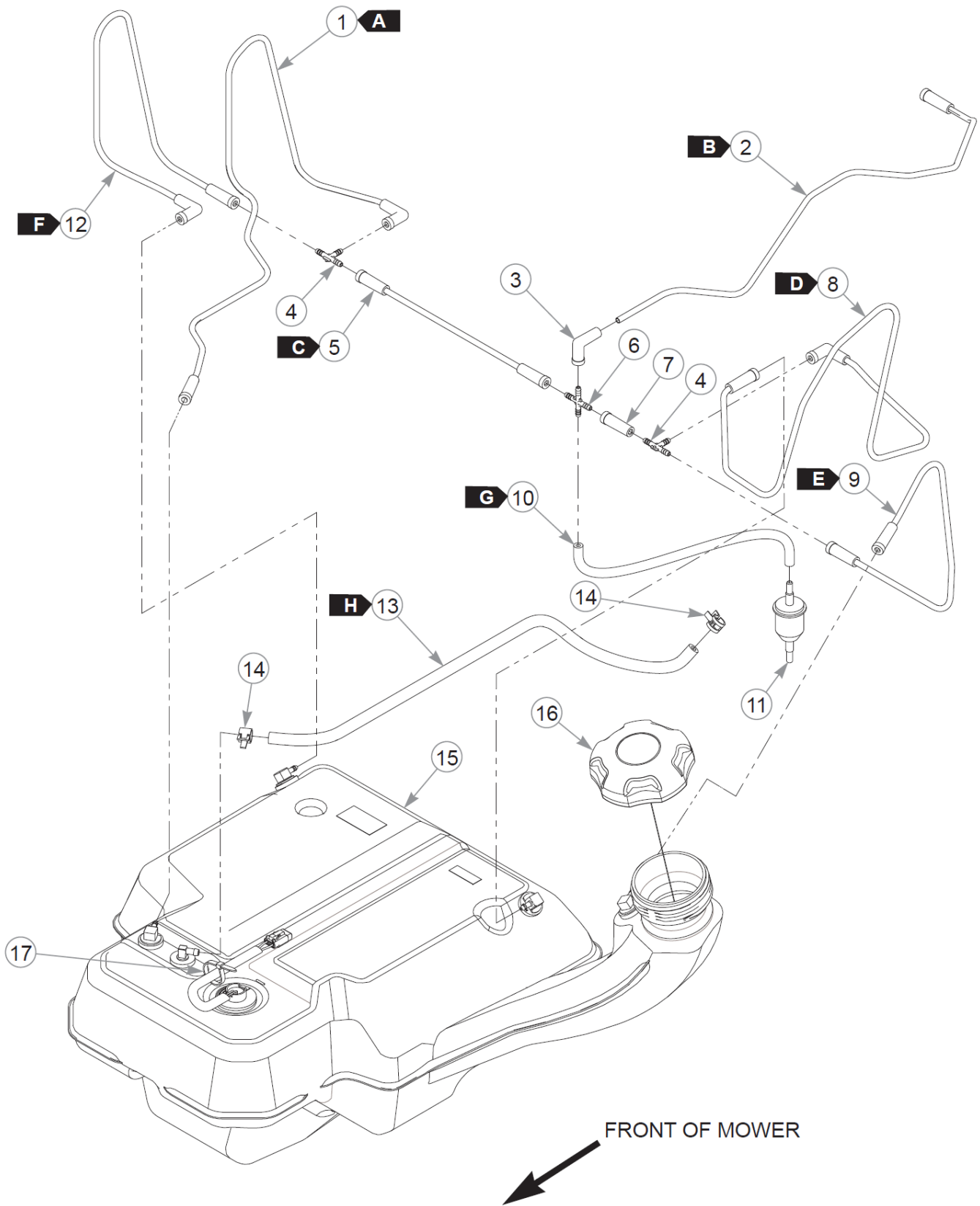

This page intentionally left blank

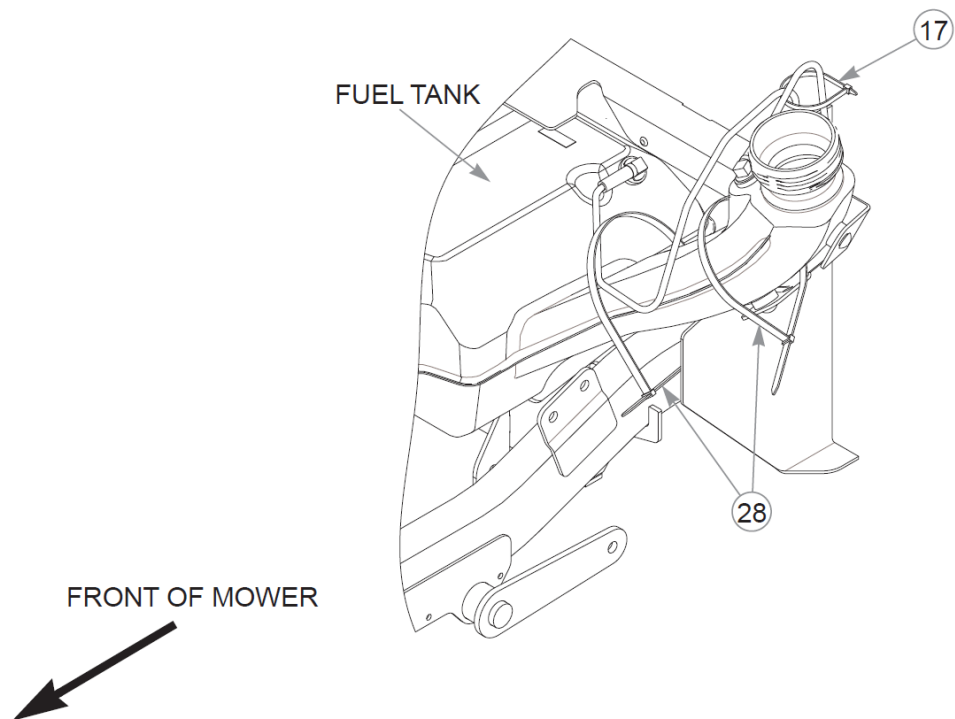
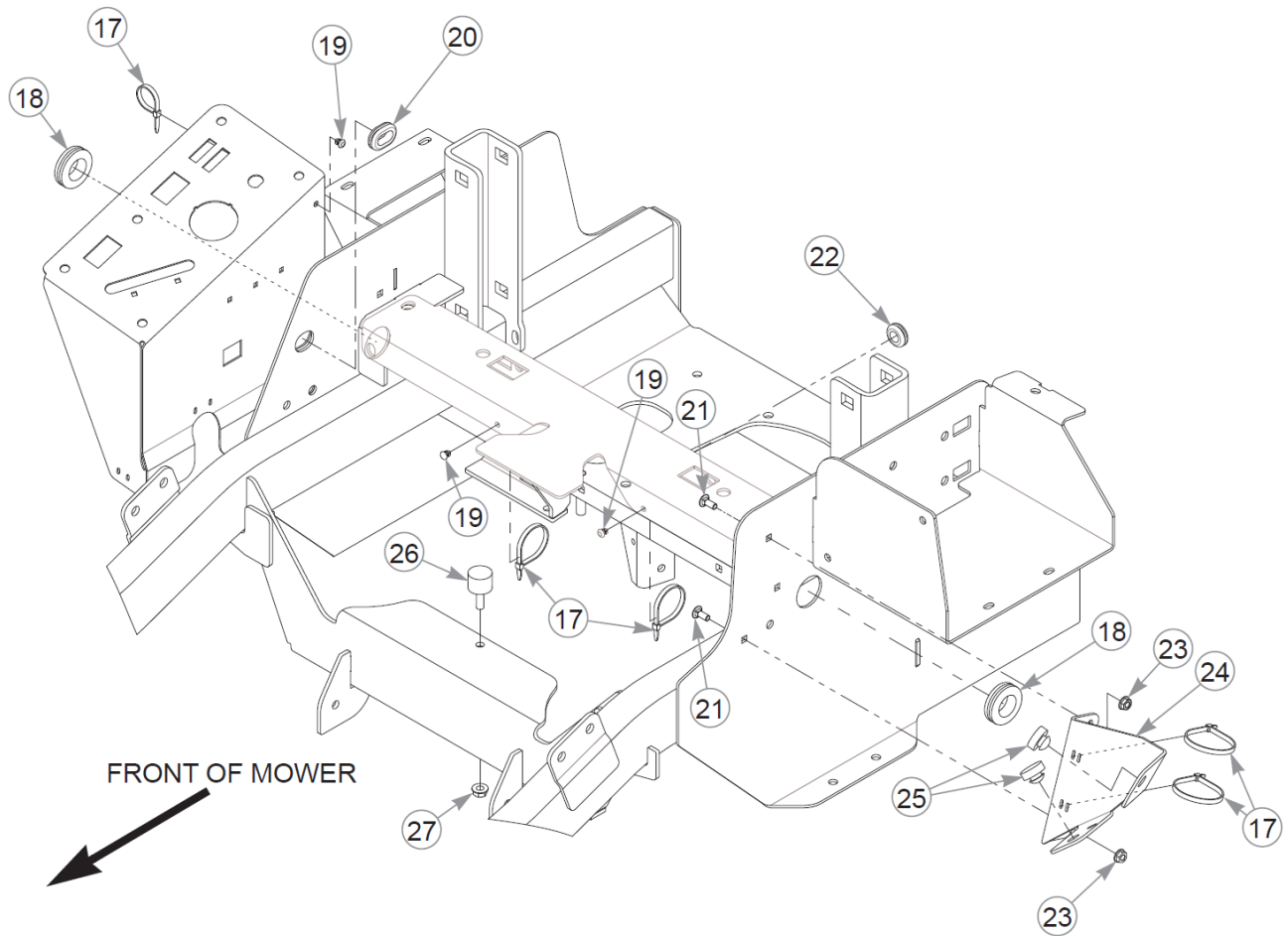

Fuel System (Multi-Page)

Item	Part No.	Qty	Name
1	605491	1	VAPOR LINE, 3/16 FORMED
2	605493	1	VAPOR LINE, 3/16 FORMED
3	605565	1	BOOT, 3/16 TO 3/16
4	605690	2	TEE, 3/16" PLASTIC
5	605535	1	VAPOR LINE, 3/16 FORMED
6	605425	1	CROSS, 3/16" PLASTIC
7	605564	1	BOOT, 3/16 TO 3/16
8	605534	1	VAPOR LINE, 3/16 FORMED
9	605492	1	VAPOR LINE, 3/16 FORMED
10	603326	12"	VAPOR LINE, 3/16"
Comments for Part Num. 603326			
Sold by the foot.			
11	604323	1	VAPOR SYSTEM FILTER
12	605533	1	VAPOR LINE, 3/16 FORMED
13	015818	23"	FUEL LINE, 1/4"
Comments for Part Num. 015818			
Sold by the foot.			
14	000323	2	CLIP, HOSE CLAMP
15	607667	1	FUEL TANK ASSY
16	603807	1	CAP, 3.5" RATCHETING GAS
17	000331	10	WIRE TIE, SMALL/SHORT
18	706531	2	GM 1.12X1.75X1.37X.12
19	604307	3	MOUNT, PUSH BUTTON
20	047456	1	GM .750X.188X1.00X.12
21	601503	2	CB .250-20 X .625 ZN
22	080358	1	GM .50X1.00X.75X.12
23	016816	2	NT .250-20FLKG5
24	124348-1	1	TANK NECK SUPPORT
25	781880	2	BUMPER, .500x 1.00x .31
26	605542	1	ISOLATOR
27	016832	1	NT .312-18FLKG5
28	602725	2	WIRE TIE,

Comments for Page: Fuel System (Multi-Page)

Fuel System (Multi-Page)

FUEL & VAPOR LINE LENGTHS

A: FRONT RIGHT SIDE PORT TO TEE (VAPOR)

B: ENGINE TO CROSS (VAPOR)

C: TEE TO CROSS (VAPOR)

D: LEFT BACK PORT TO TEE (VAPOR)

E: FILLER NECK PORT TO TEE (VAPOR)

F: RIGHT BACK PORT TO TEE (VAPOR)

G: 12" CROSS TO FILTER (VAPOR)

H: 23" TANK TO FUEL FILTER

This page intentionally left blank

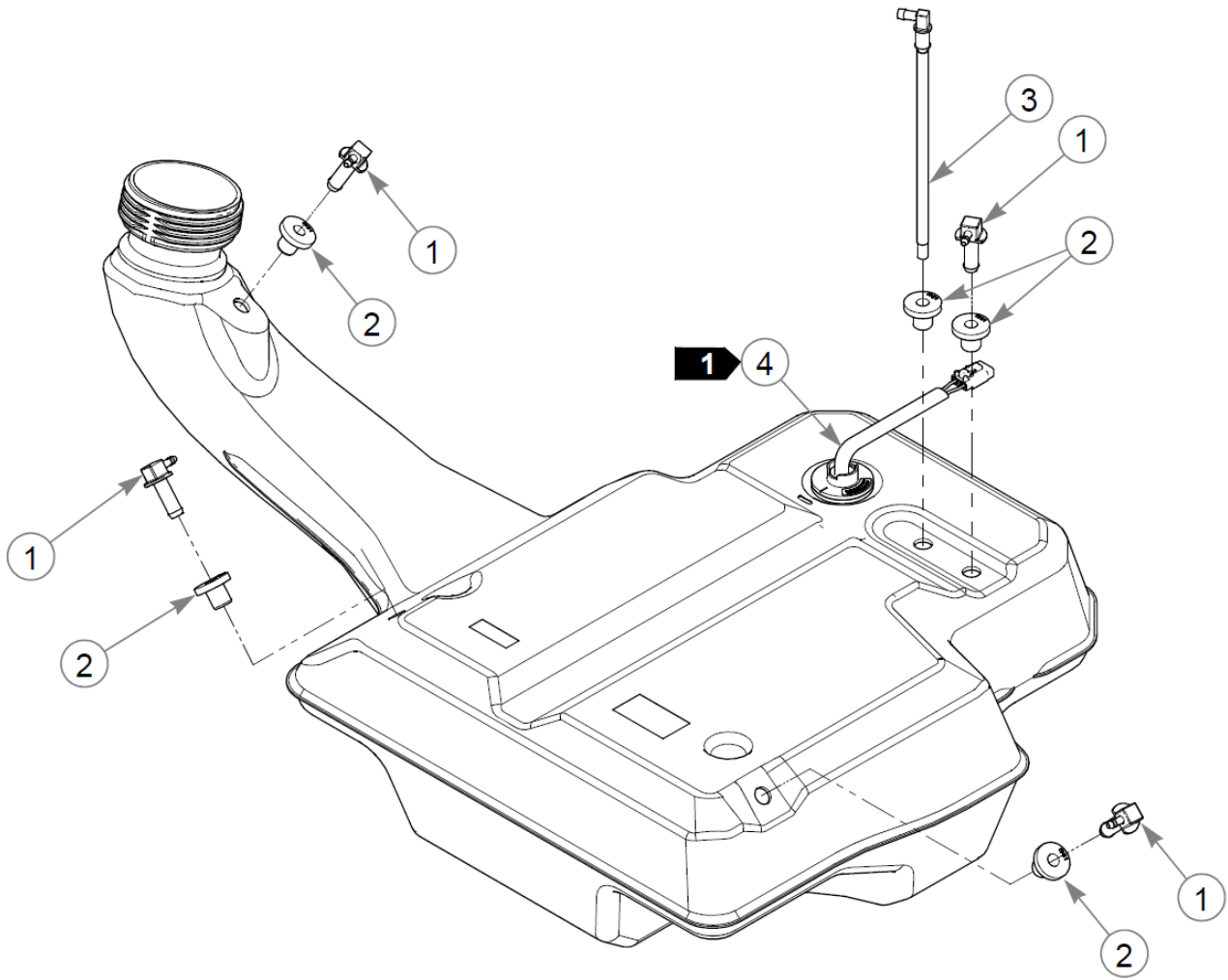

Fuel Tank Service Parts - 607667

Item	Part No.	Qty	Name
1	604287K	3	VENT FITTING SVC KIT
2	604200K	5	GROMMET SVC KIT
3	605126K	1	SUCTION HOSE SVC KIT
4	607453K	1	SENDER SVC KIT
Not Shown	608043	1	FUEL GAUGE & SENDER KIT

Comments for Page: Fuel Tank Service Parts - 607667

1. 607453 is used on mowers S/N 20054498 & HIGHER.

608043 is used on mowers S/N PRIOR TO 20054498.

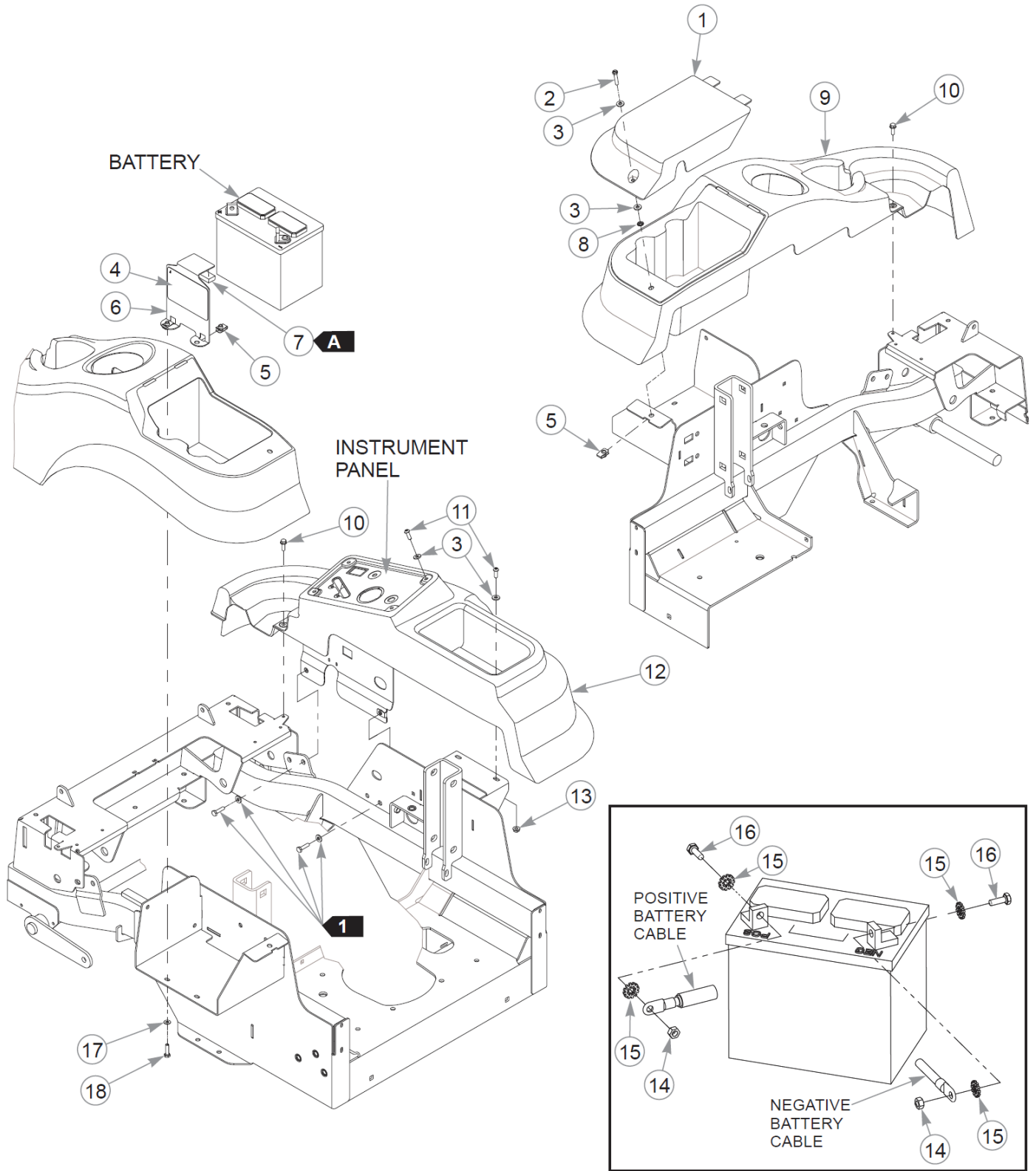

Fenders & Battery

Item	Part No.	Qty	Name
1	605558	1	FENDER LID
2	605627	1	CS .250-20 X 1.25 HX
3	605628	8	FW 0.281X.63X.07 ZB
4	601815	1	DECAL, BATTERY WARNINGS
5	601982	3	CN .250-20X .150 MAX THK
6	552858	1	BATTERY HOLD DOWN
7	713198	2.5"	SEAL 3/8x3/4 SOLD BY FT
8	605629	1	UNTHREADED PN 0.250 ID
9	605522	1	LH FENDER
<p>Comments for Part Num. 605522</p> <p>The 'decals' which are on this fender are 'in-mold labels' and not available for purchase separately.</p>			
10	604324	2	CS .250-20 X .75 HX FLG
11	605473	6	CS .250-20X0.75 BH TX BZ
12	605521	1	RH FENDER
<p>Comments for Part Num. 605521</p> <p>The 'decals' which are on this fender are 'in-mold labels' and not available for purchase separately.</p>			
13	016816	2	NT .250-20FLKG5
14	024927	2	NT .250-20HXG5
15	029868	4	LW .250 INTEXT ZN
16	055939	2	CS .250-20X0.75 HX G5 ZN
17	017079	2	FW .250SAE
18	056077	2	CS .250-20X1.000HXG5

Comments for Page: Fenders & Battery

1. Part of the Instrument Panel assembly.
2. When performing service on the mower, disconnect the negative battery cable (black) and do not reconnect it to the battery until ready to start the engine.
3. The battery hold down includes the seal and decal.

SEAL LENGTH

A : 2.5"

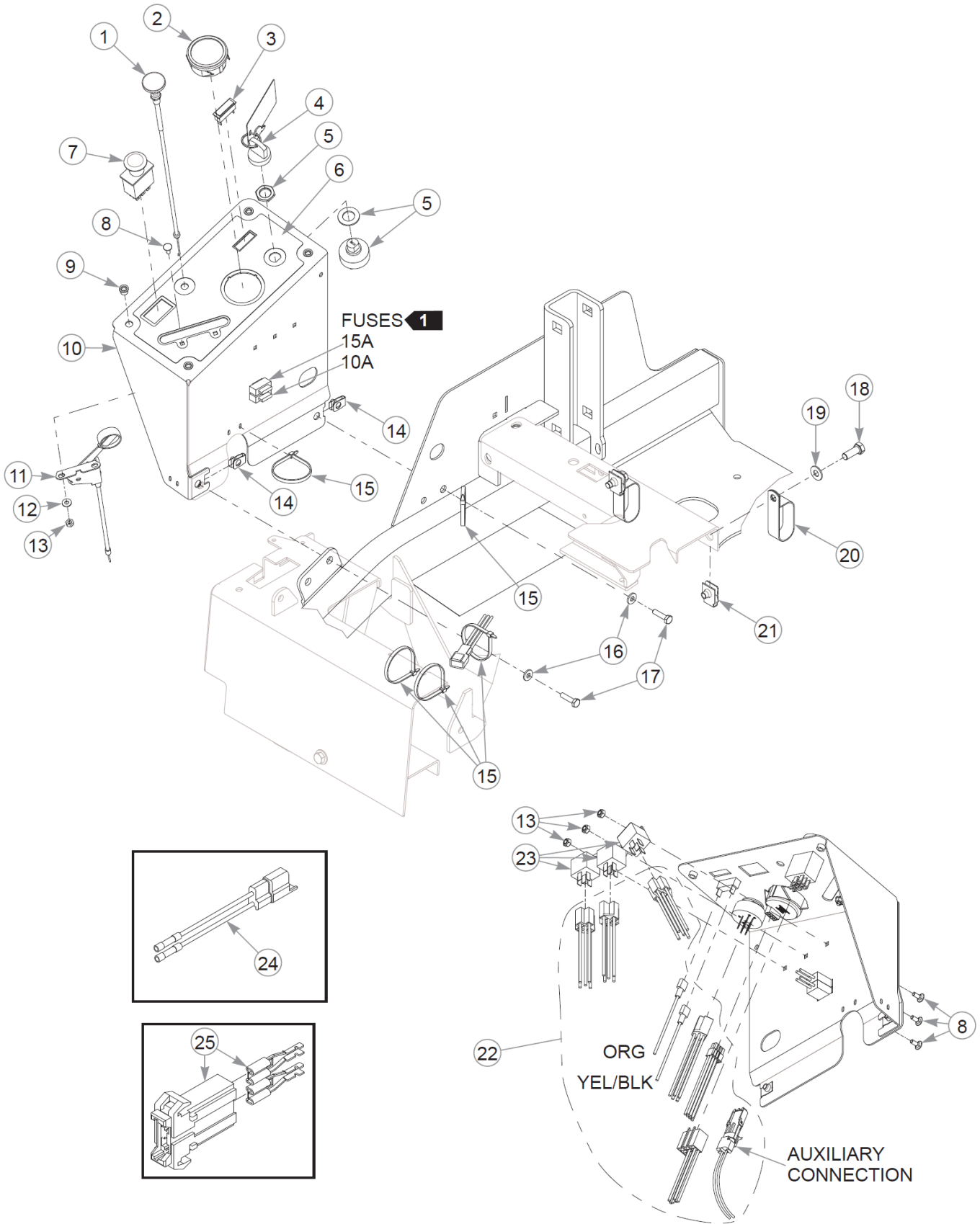

Instrument Panel & Wire Harness

Item	Part No.	Qty	Name
1	786657	1	CABLE, CHOKE
2	607452	1	GAUGE, SING NEEDLE 12V
3	712257	1	INDICATOR LIGHT, RED(FS)
4	785808	1	KEY ASSEMBLY
5	045898	1	IGNITION SWITCH
6	605605	1	DECAL, INST PANEL
7	776476	1	SWITCH, PTO 6201-321
8	601098	5	CB 10-24 X .500 ZYNC
9	808477	4	RIVET NUT, 1/4-20 THREA
10	552854	1	INSTR PANEL (W/DECAL)
11	778365	1	CABLE, THROTTLE
12	704932	2	FW 0.219X.50X.05 ZN
13	059832	5	NT #10-24 HX NL ZN
14	601982	2	CN .250-20X .150 MAX THK
15	000331	7	WIRE TIE, SMALL/SHORT
16	768515	2	FW 0.281SAE
17	056077	2	CS .250-20X1.000HXG5
18	036244	2	CS .375-16X1.00 HX G5 ZN
19	767954	2	FW 0.379X.82X.06 HD ZN
20	045088	2	HOSE CLAMP 1" (FS)
21	601758	2	CN .375-16x.200 MAX THK
22	605458	1	WIRE HARNESS, FSD/SMP
23	601053	3	RELAY, SEALED W/BRACKET
24	114052	1	KIT, CLUTCH CONN. REP.
25	601047	1	HOLDER, FUSE

Comments for Page: Instrument Panel & Wire Harness

1. Part of the wire harness.
2. The instrument panel includes the decal.
3. The sealed relay includes a bracket.

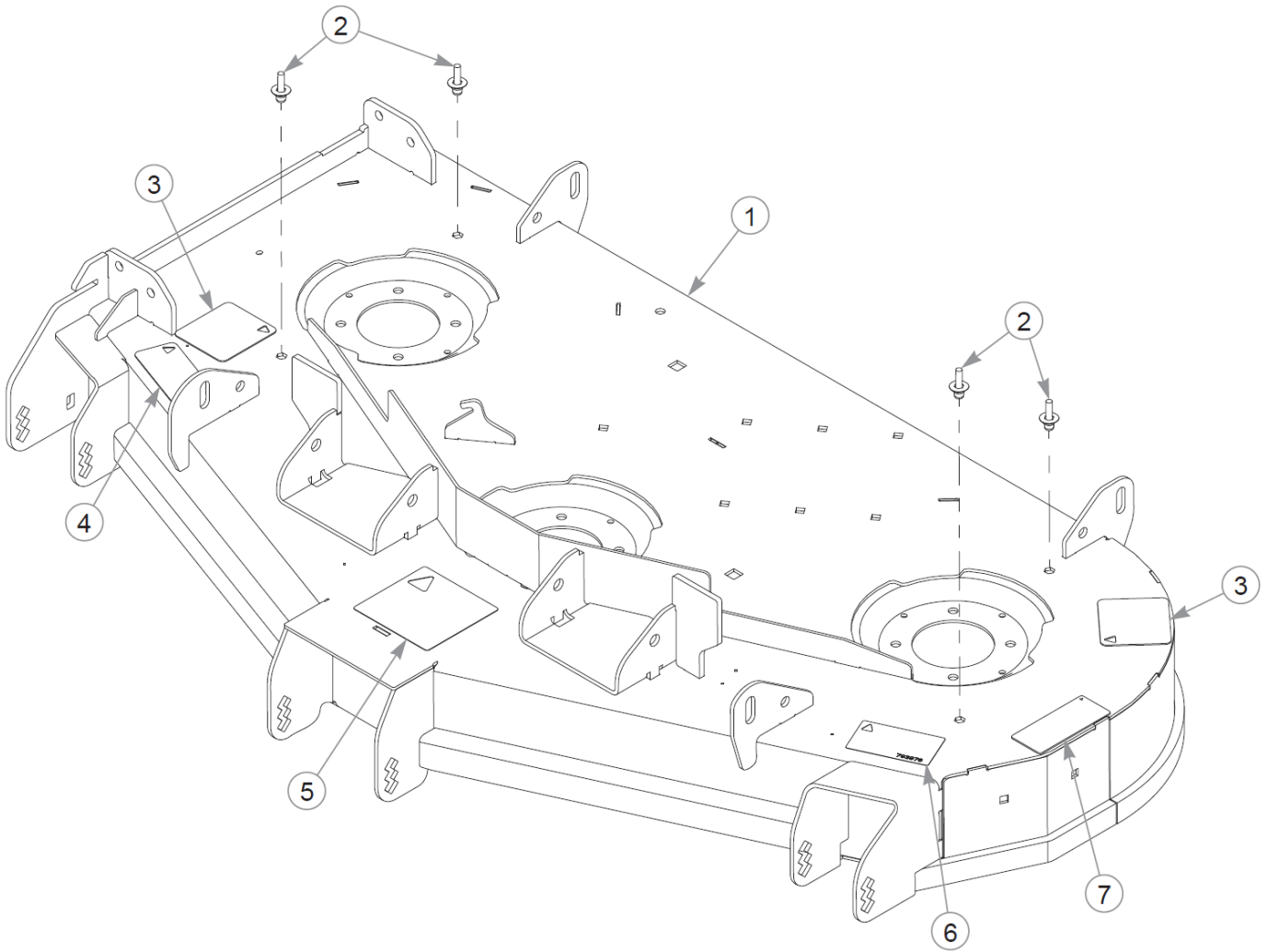

Service Deck

Item	Part No.	Qty	Name
1	554857	1	48" SERVICE DECK
2	607583	4	0.25-20 X 0.625
3	601837	2	DECAL, DECK DANGERS
4	601624	1	DECAL, DISCHARGE CHUTE
5	781419	1	DECAL, BELT ROUTING
6	793976	1	DECAL,48"DECK ID
7	601892	1	DECAL, THROWN OBJECTS

Comments for Page: Service Deck

1. The deck includes the decals and threaded studs.

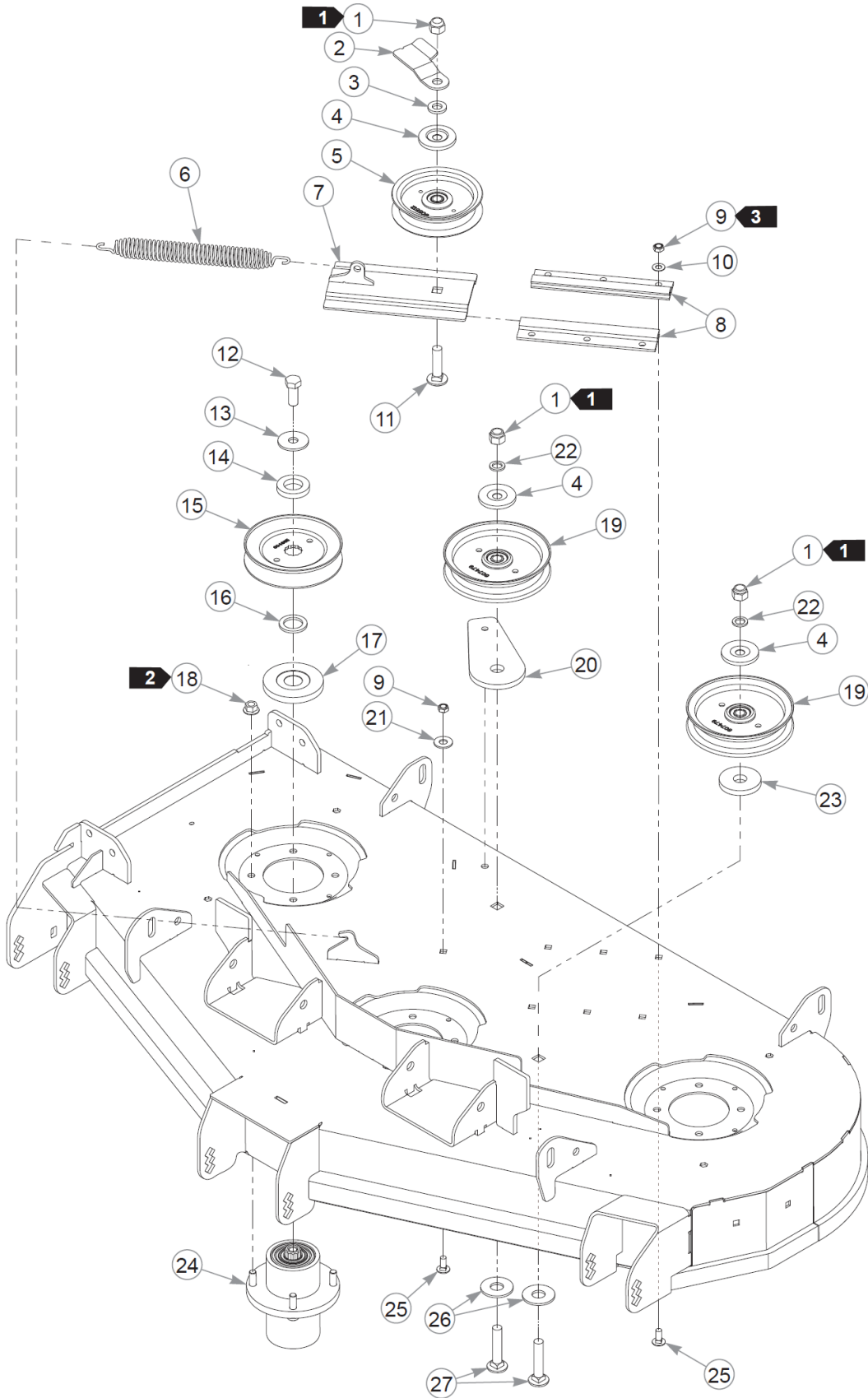

Deck Pulleys & Spindles

Item	Part No.	Qty	Name
1	781567	3	NT .500-13NLG5
2	125847-4	1	BELT GUIDE, 4.00" IDLER
3	607428	1	FW 0.531 X 0.90 X 0.134
4	605467	3	DUST SHIELD
5	605512	1	4" IDLER PULLEY
6	607616	1	SPRING, DECK IDLER
7	121052	1	SLED, TENSIONER
8	604790	2	IDLER SLIDE, EXTRUDED
9	604251	7	NT .312-18 HXNL JAM G2ZN
10	604252	6	FW .340X.68X.04 ZN
11	604253	1	CB .50-13 X 2.00 STD ZN
12	705954	3	CS .500-13X1.25 HX G5 ZN
13	798603	3	FW .515X1.65X.12 HD ZN
14	604777	3	SPINDLE SPACER
15	604665	3	PULLEY, DECK DRIVE B-SEC
16	045765	3	FW 1.030X1.50X.13 HD ZN
17	606362	3	DUST SHIELD
18	604515	12	NT .375-16 FL NY GF
19	607479	2	IDLER PULLEY, 5.00"
20	605465	1	BASE, IDLER PULLEY MOUNT
21	017129	1	FW .440X1.00X0.08 ZN
22	604486	2	FW .531X.812X.089 HD
23	605508	1	FW .73X2.25X.31 ZN
24	607208	3	BLADE SPINDLE ASSY
25	016253	7	CB .312-18X .750 FUL ZN
26	608374	2	FW 0.719 X 1.75 X 0.125
27	604254	2	CB .50-13 X 2.50 STD ZN

Comments for Page: Deck Pulleys & Spindles

1. Torque to 73 ft-lbs.
2. Torque to 30 ft-lbs.
3. Torque to 3–6 ft-lbs.

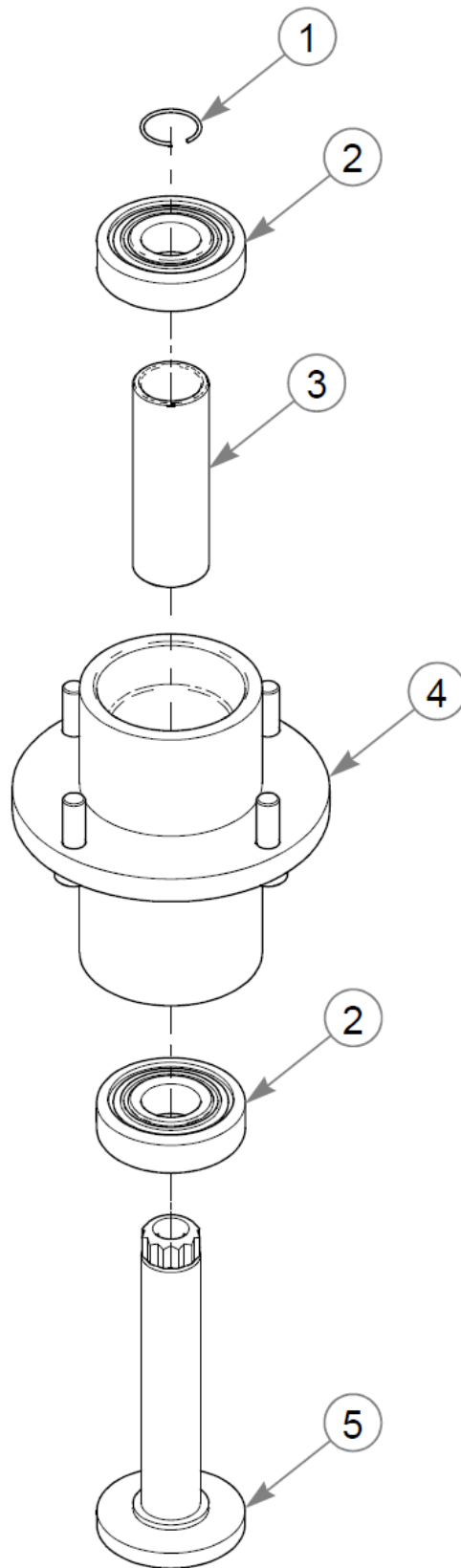

Spindle Service Parts - 607208

Item	Part No.	Qty	Name
1	783548	1	RING, BLADE SPINDLE RET
2	607275	2	BLADE SPINDLE BEARING
3	607210	1	BLADE SPINDLE SPACER
4	607417	1	SVC, SPINDLE HOUSING
5	607211	1	BLADE SPINDLE SHAFT

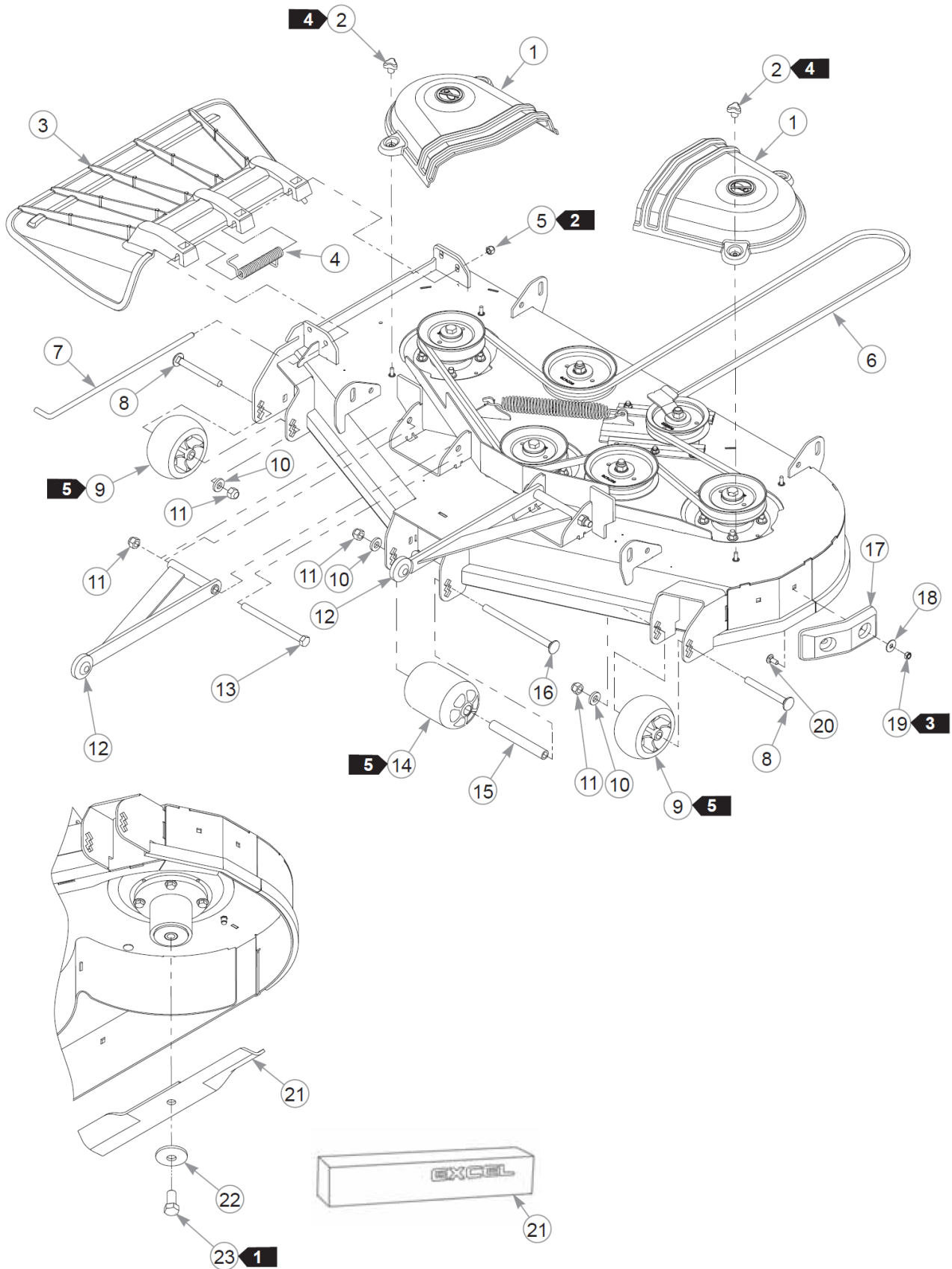

Item	Part No.	Qty	Name
1	605867	2	PULLEY COVER, UNIVERSAL
2	607186	4	.25-20 FEMALE KNOB
3	605469	1	DISCHARGE CHUTE
4	602435	1	SPRING, TORSION
5	086660	1	NT .375-16NLG8
6	791335	1	DECK BELT
7	602432	1	PIN, CHUTE
8	602339	2	CB .50-13 X 4.50 STD ZN
9	604780	2	WHEEL, ANTI-SCALP
10	767962	3	FW .531 x 1.063 x .175
11	781567	5	NT .500-13NLG5
12	113717	2	PULLER W/A 14.53" C/C
13	042630	2	CS .500-13X6.500HXG5
14	602341	1	WHEEL, ANTI-SCALP
15	602344	1	SPACER, ANTI- SCALP 5.73
16	602338	1	CB .50-13 X 7.50 STD ZN
17	605376	1	DECK BUMPER
18	079210	2	FW 0.344X1.0X0.06 ZN
19	604251	2	NT .312-18 HXNL JAM G2ZN
20	016253	2	CB .312-18X .750 FUL ZN
21	606252	3	BLADE, 16.5"-H-F-CW
Not Shown	606252X	1	10PK BLADE 16.50"-H-F-CW
Not Shown	795757	3	BLADE, F16.50"-H-F-CW
Not Shown	795757X	1	10PK BLADE, F16.50"-H-F-
Not Shown	601014	3	BLADE, F16.50"-L-F-CW
Not Shown	601014X	1	10PK BLADE, F16.50-L-F-C
Not Shown	601123	3	BLADE, 16.50"-L-F-CW
Not Shown	601123X	1	10PK BLADE, 16.50"-L-F-C
Not Shown	796623	3	BLADE, 16.50"-MUL-F-CW
Not Shown	796623X	1	10PK BLADE, 16.50"-MUL-F
Not Shown	796631	3	BLADE, 16.50"-GAT-F-CW
Not Shown	796631X	1	10PK BLADE, 16.50"-GAT-F
22	782474	3	CW .678 X 2.250 X .187
23	781872	3	CS .625-11X1.250HXG5

Comments for Page: Deck Belt, Discharge Chute, Pulley Covers & Blades

1. Torque to 118 ft-lbs.
2. Do not torque; the discharge chute must pivot freely.
3. Torque to 3–6 ft-lbs.
4. Torque these knobs to 15 in-lbs.
5. Tighten to remove play in the bolt; the anti-scalp wheels and puller brackets must pivot freely.

This page intentionally left blank

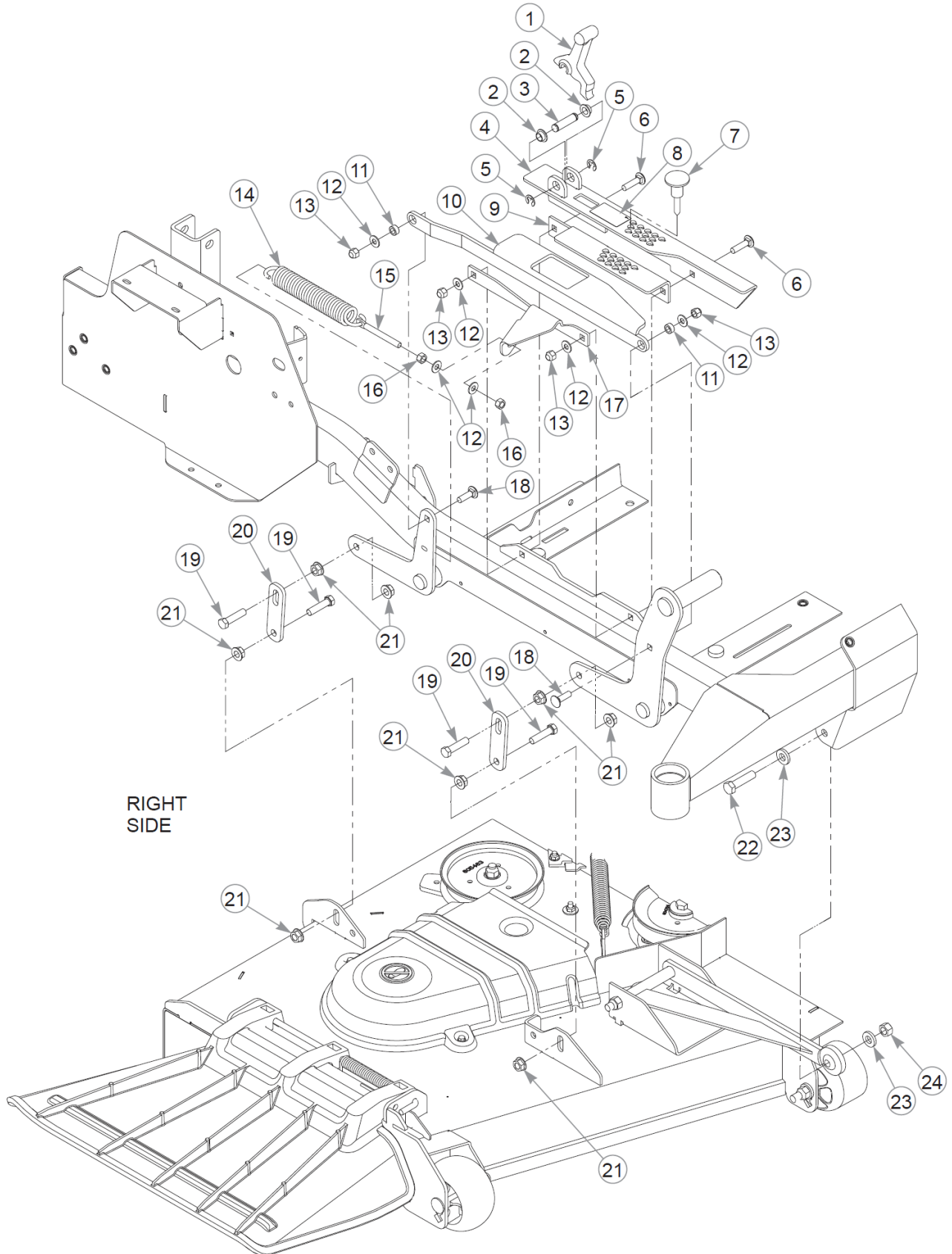

This page intentionally left blank

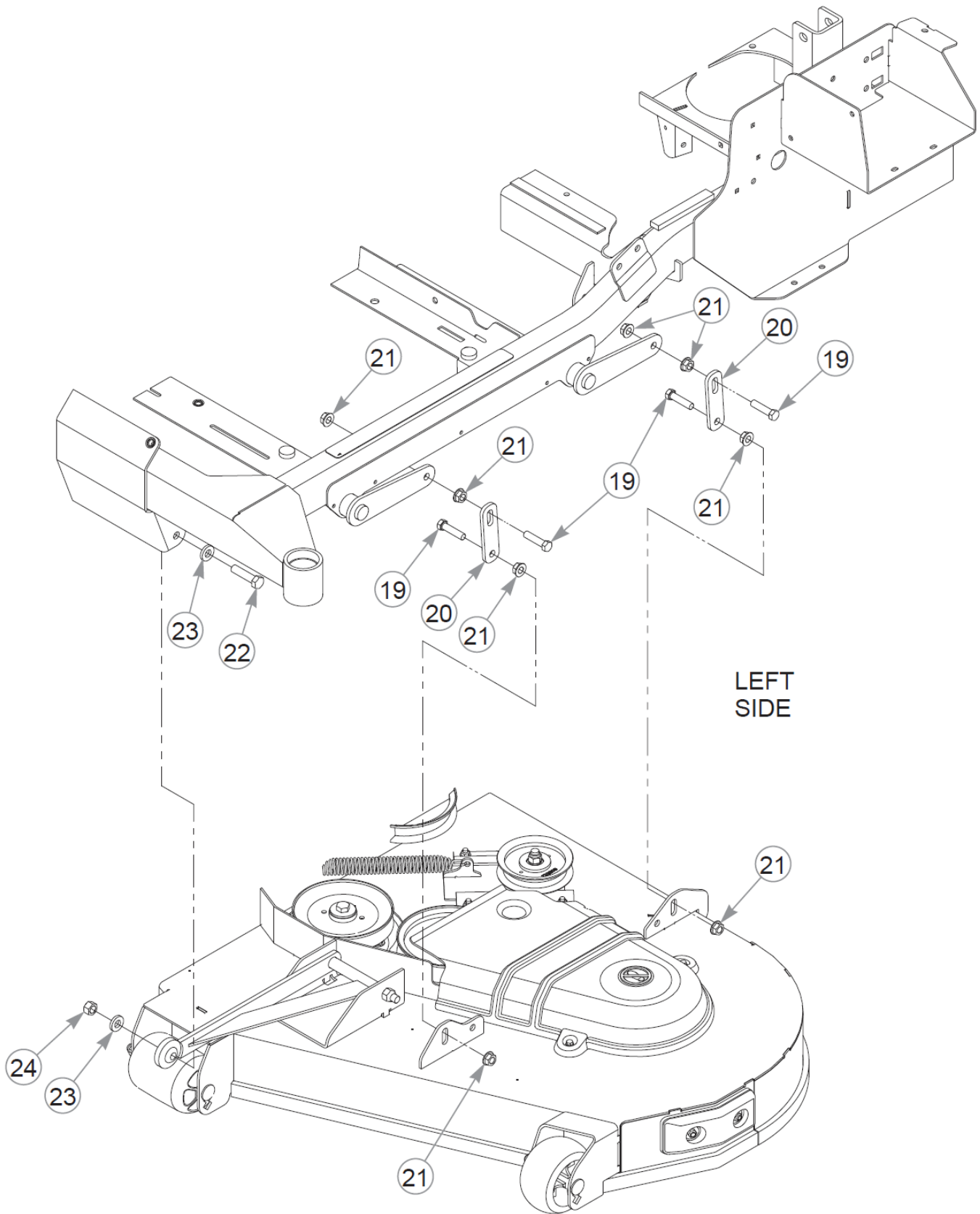

Deck Lift & Deck Mounting Hardware (Multi-Page)

Item	Part No.	Qty	Name
1	605466	1	TRANSPORT LATCH
2	768259	2	BUSHING,IGUS#0810 (FS)
3	605470	1	CE .500X2.00X1.63
4	552859	1	INDICATOR PLATE
5	793059	2	CLIP E,(1/2"),.80X.396X.
6	710194	2	CB .375-16X 1.50 STD G5
7	607039	1	PIN, .375X1.62 MAGNETIC
8	605538	1	DECAL, DECK HEIGHT
9	119970	1	CUT HEIGHT BRKT, INNER
10	119969	1	INDICATOR BRACKET
11	118900	2	SPACER, DECK LIFT LINK
12	767954	6	FW 0.379X.82X.06 HD ZN
13	086660	4	NT .375-16NLG8
14	008938	1	TENSION SPRING-PLATED
15	601486	1	EB, .375-16X3.00 FULTHD
16	054502	2	NT .375-16HXG5
17	120779	1	ASSIST SPRING BRKT
18	603113	2	CB .375-16X1.250 G5 ZN
19	055749	8	CS .437-14X1.750HXG5
20	124354-1	4	DECK LIFT LINK
21	704643	16	NT .437-14FLKG5
22	078949	2	CS .500-13X2.000 FUL HX
23	767962	4	FW .531 x 1.063 x .175
24	008193	2	NT .500-13HXG5

Comments for Page: Deck Lift & Deck Mounting Hardware (Multi-Page)

1. The indicator plate includes the decal.

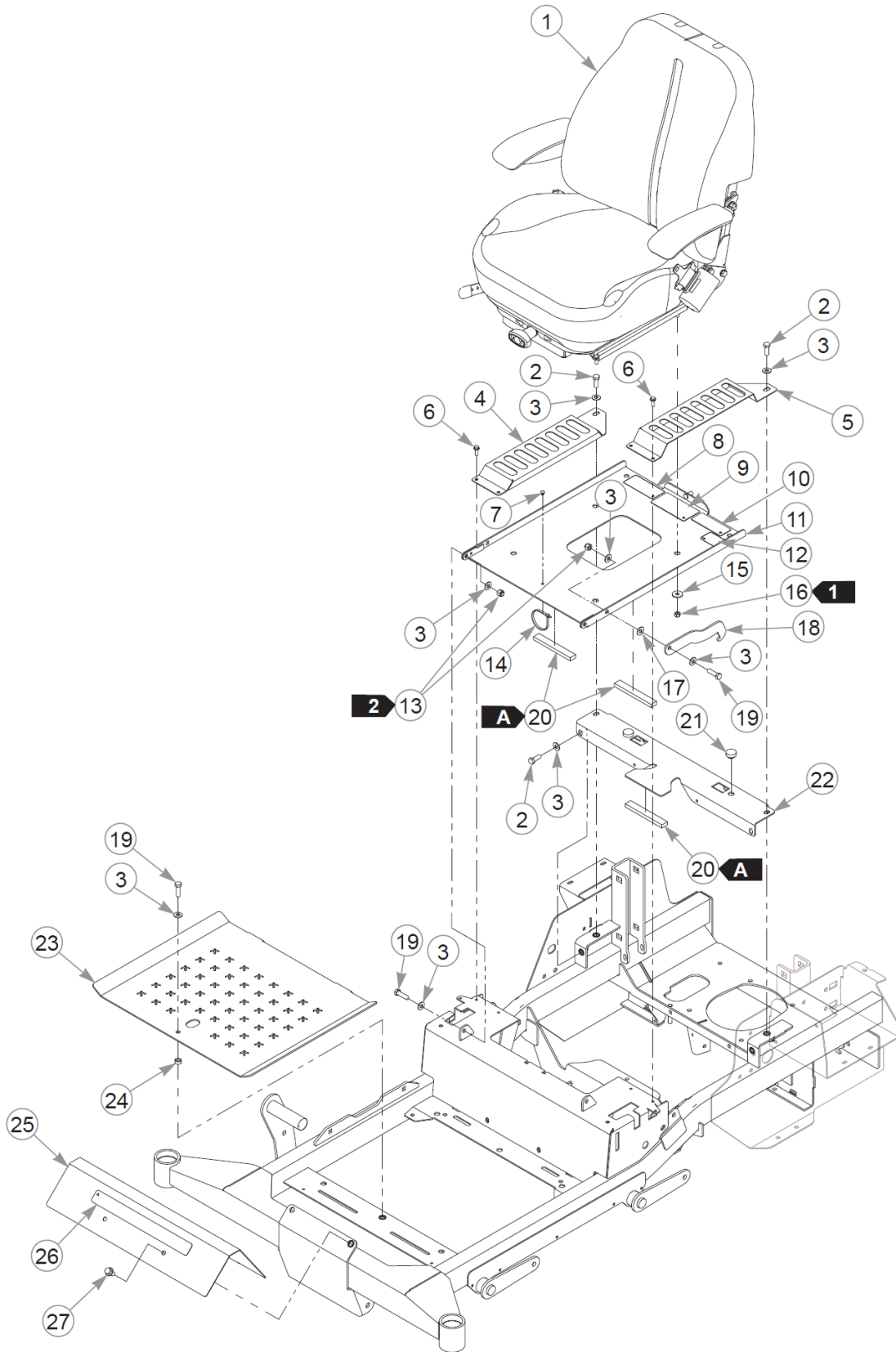

This page intentionally left blank

SEAT SUPPORT

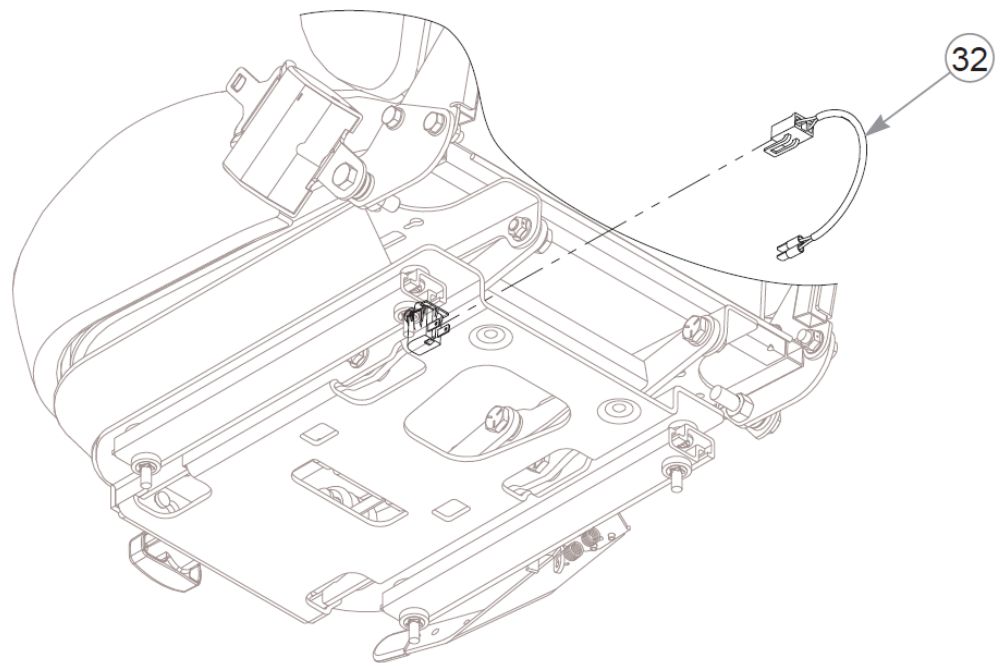
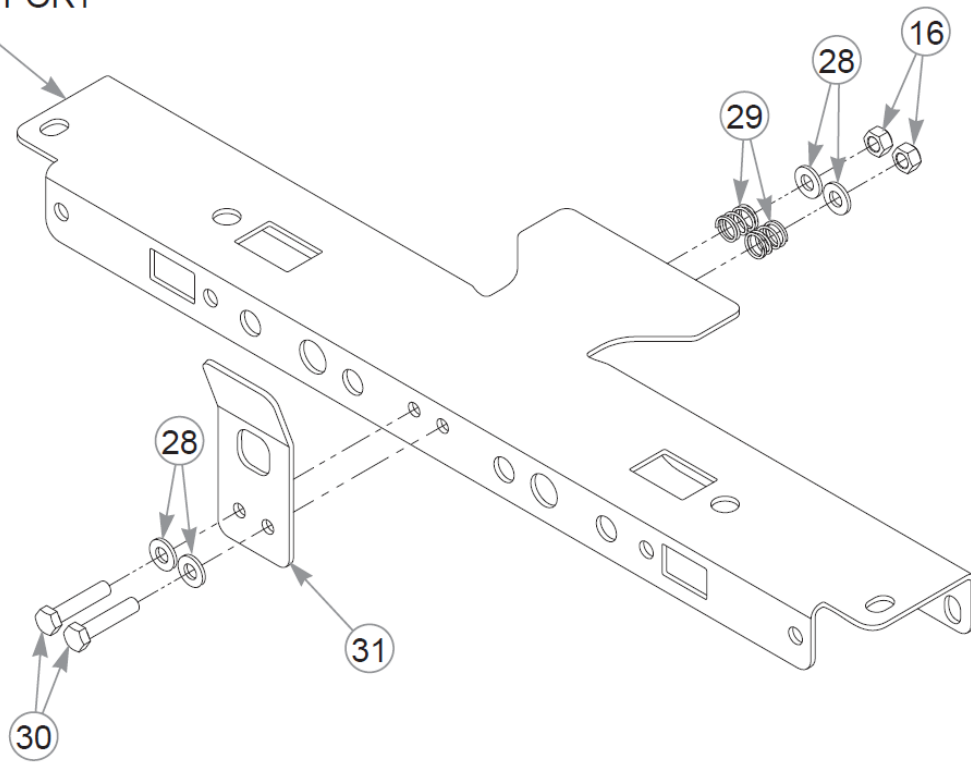

Item	Part No.	Qty	Name
1	608048	1	SEAT, SEATS INC 1110
2	036244	4	CS .375-16X1.00 HX G5 ZN
3	767954	11	FW 0.379X.82X.06 HD ZN
4	123688-1	1	HYDRO GUARD, RH
5	123689-1	1	HYDRO GUARD, LH
6	604324	4	CS .250-20 X .75 HX FLG
7	604307	1	MOUNT, PUSH BUTTON
8	601967	1	DECAL, ENGINE COMPART
9	600899	1	DECAL, PUMP BELT WARNING
10	779280	1	DECAL, HOT & HYD OIL
11	554679	1	SVC SEAT PAN
12	605782	1	DECAL, LEVEL FUEL BLOWM
13	086660	3	NT .375-16NLG8
14	000331	1	WIRE TIE, SMALL/SHORT
15	712927	4	FW 0.344X1.00X.12 HD ZN
16	058776	6	NT .312-18NLG5
17	724716	1	WASHER, FIBER (FS)
18	124558-4	1	SEAT STOP
19	052860	4	CS .375-16X1.25 HX G5 ZN
20	713198	15"	SEAL 3/8x3/4 SOLD BY FT
21	781880	2	BUMPER, .500x 1.00x .31
22	552848	1	SEAT SUPPORT (WITH TAPE)
23	124567-1	1	FLOOR PAN
24	118900	1	SPACER, DECK LIFT LINK
25	554682	1	SVC FOOT REST
26	602407	1	DECAL, HUSTLER ID
27	029629	2	CS .375-16X0.75 HXF G5ZN
28	768523	4	FW 0.343SAE
29	607046	2	SPRING, COMPRESSION
30	756270	2	CS .312-18X1.500HXG5
31	124572-4	1	LATCH, SEAT
32	607088	1	JUMPER HARNESS

Comments for Page: Seat, Footrest & Floor Pan (Multi-Page)

1. Torque to 17 ft-lbs.

Seat, Footrest & Floor Pan (Multi-Page)

2. Do not torque; the seat pan and seat stop must pivot freely.
3. The seat pan and footrest include the decals.
4. The seat support includes the seal.

SEAL LENGTH

A: 5.0"

This page intentionally left blank

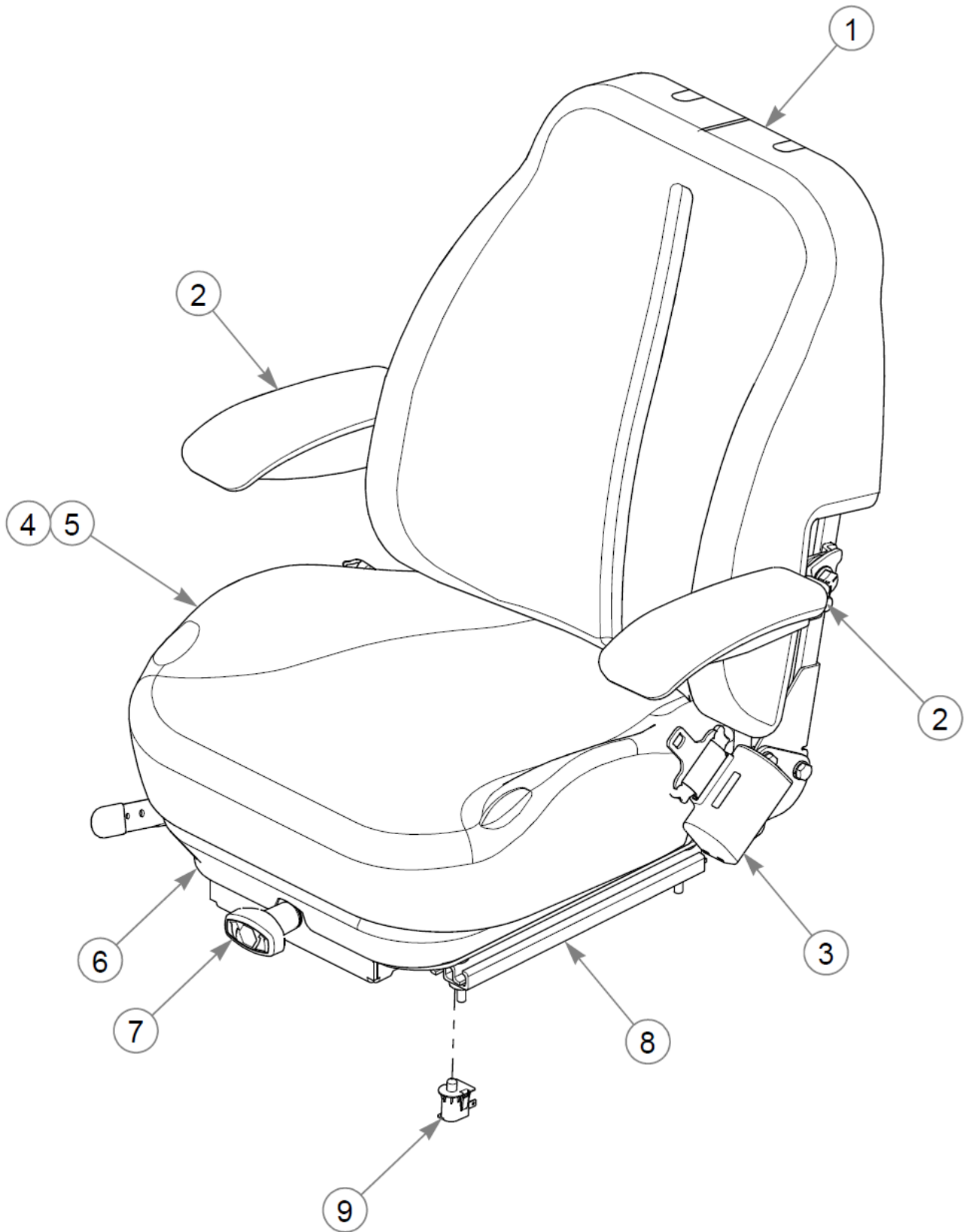

Seat Service Parts

Item	Part No.	Qty	Name
Not Shown	608048	1	SEAT, SEATS INC 1110
1	608051	1	SVC, MID BACK COVER
2	606080	1	SVC, ARMREST SET
3	607461	1	SVC, SEAT BELT KIT
4	608350	1	SVC, SEAT FOAM 1110
5	608049	1	SVC, SEAT CUSHION COVER
6	607460	1	SVC, RUBBER BELLOW
7	607214	1	SVC RIDE ADJUST KNOB
8	607459	1	SVC, SEAT TRACK KIT
9	606082	1	SVC, OPS

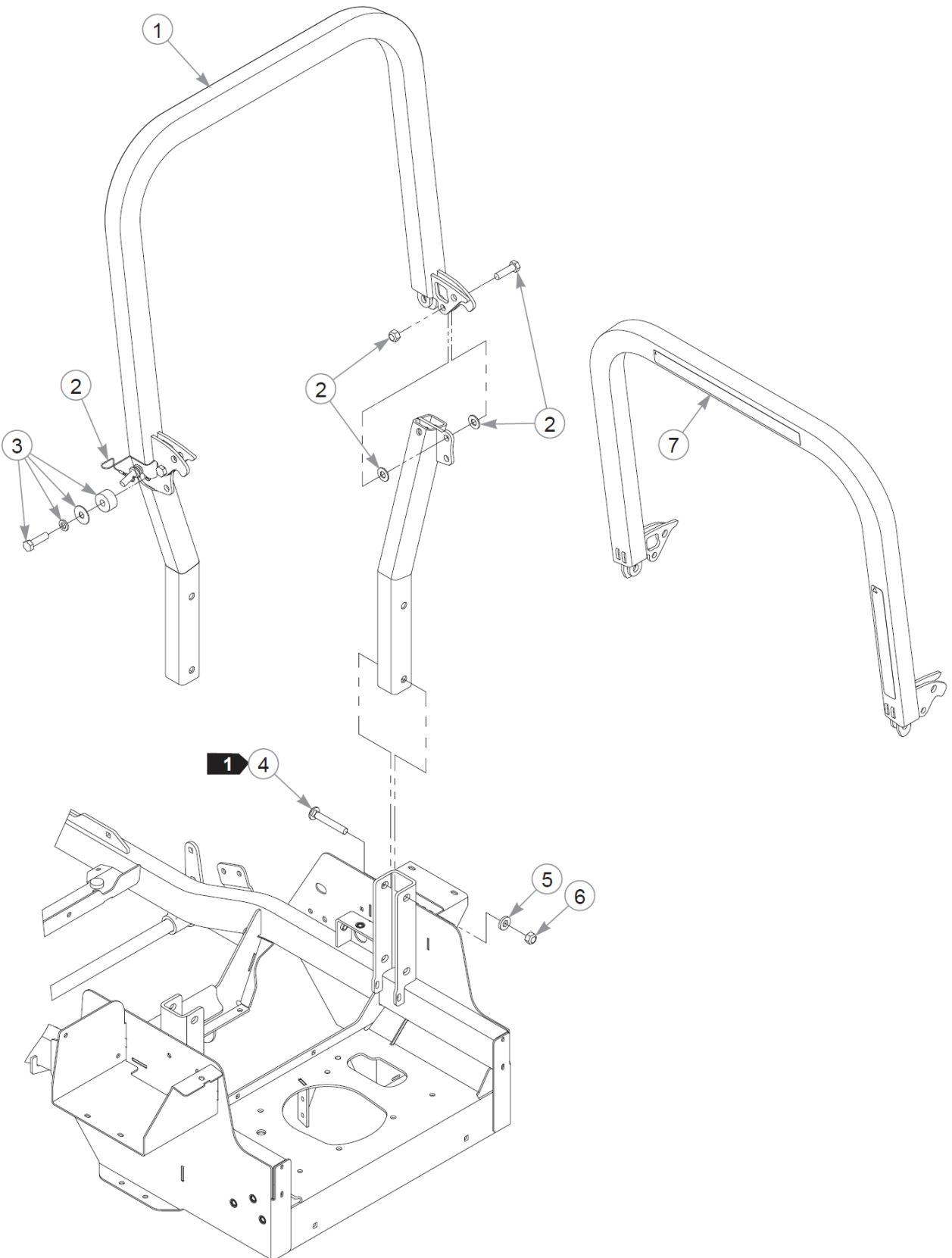

ROPS

Item	Part No.	Qty	Name
1	605479	1	ROPS ASSY
2	605044	1	KIT, ROPS HARDWARE
3	605646	2	KIT, POLY STOP (PAIR)
4	607008	4	CB .50-13 X 3.25 GR5
5	767962	4	FW .531 x 1.063 x .175
6	023317	4	NT .500-13UNTG8
7	605691	1	DECAL, COMMERCIAL DUTY

Comments for Page: ROPS

1. Torque to 73 ft-lbs.