



HUSTLER[®] X-RIDE[™] OPERATOR'S MANUAL



WARNING

The engine exhaust from this product contains chemicals known to the state of California to cause cancer, birth defects or other reproductive harm.

NOTICE OF REQUIREMENT OF SPARK ARRESTER MUFFLER

This equipment may create sparks that can start fires around dry vegetation. California Public Resources Code Section 4442.6 provides that it is unlawful to use or operate an internal combustion engine on any forest-covered, brush-covered, or grass-covered land unless the engine is equipped with a spark arrester maintained in effective working order. A spark arrester is a device constructed of nonflammable materials specifically for the purpose of removing and retaining carbon and other flammable particles over 0.0232 of an inch in size from the exhaust flow of an internal combustion engine that uses hydrocarbon fuels or which is qualified and rated by the United States Forest Service. Other states or federal areas may have similar laws. The Operator Should Contact Local Fire Agencies For Laws or Regulations Relating to Fire Prevention Requirements. **THIS EQUIPMENT DOES NOT HAVE A SPARK ARRESTER AND YOU SHOULD CONTACT YOUR AUTHORIZED DEALER FOR THE PURCHASE OF A SPARK ARRESTER.**

Inspect spark arrester daily; replace every 500 hours or as needed.

The Engine Owner's Manual provides information regarding the U.S. Environmental Protection Agency (EPA) and the California Emission Control Regulation of emission systems, maintenance and warranty.

Keep Engine Owner's Manual with your unit. Should the Engine Owner's Manual become damaged or illegible, replace immediately. Replacements may be ordered per the information found in the Product Information section of the owner's manual.

Federal law and California State law prohibit the following acts or the causing thereof:

- 1. The removal or rendering inoperative by any person other than for purposes of maintenance, repair, replacement, of any device or element of design incorporated into any equipment for the purposes of emissions control prior to or after its sales or delivery to the ultimate purchaser or while it is in use, or**
- 2. The use of the equipment after such device or element of design has been removed or rendered inoperative by any person.**

GENERAL INFORMATION

To the New Owner

Read the manual carefully. It contains operation and maintenance information that will help you achieve years of dependable service. The Engine Owner's Manual, included in the owner's packet, contains engine information that will not be repeated in this manual. The owner's responsibilities include, but are not limited to, making sure that the operators and mechanics:

- read and understand the engine owner's manual before attempting to operate or repair the engine.
- read and understand the mower's operator manual and all decals before operating this machine.
- are qualified and physically able individuals, properly trained in the operation and maintenance of this equipment.
- before they are allowed to operate or maintain this machine, they must be familiar with its safe operation, operator controls, and decals.
- know they are responsible for their own safety as well as the safety of other persons within the vicinity.
- the operator is responsible for accidents or hazards occurring to other people or their property.
- who cannot read and understand English have this material explained to them.

IMPORTANT: As the owner/operator you can prevent accidents. You are responsible for accidents or injuries occurring to yourself and other people or property. Never let children or untrained people operate or service the equipment. Local regulations may restrict the age of the operator. For more detailed maintenance and adjustment information refer to the proper General Service Manual for your machine. Refer to the Product Literature section of this manual for information on how to obtain this manual.

Using this Manual

This manual contains general operation information as well as basic adjustment and maintenance information. Since operating conditions vary considerably, all conditions cannot be addressed individually. Through training and experience, operators should develop safe operating practices suitable to most conditions. Directions used in this manual, for example RIGHT or LEFT, refer to directions when in the operator position and facing forward, unless otherwise stated. Though current at the time of printing, photographs and illustrations shown may vary slightly from your mower due to subsequent production changes. Hustler® Turf Equipment, Inc. reserves the right to redesign and change the machine as deemed necessary, without notification. If a change has been made to your machine which is not reflected in this manual, contact your Hustler® Dealer for current information.

Warranty Registration

There are several ways to register the mower with Hustler® Turf Equipment:

Hustler® Dealers must register the unit on-line at Hustler® Turf Dealer Login within ten (10) days following date of purchase.

Customer may register the unit on-line at Hustler® Turf Equipment or by mailing in the Warranty Registration Card, included in the owner's packet, within ten (10) days following date of purchase.

As the new equipment owner, you should confirm that your mower has been registered with Hustler® Turf Equipment.

The mower and any attachment that displays a model and serial identification number plate must be registered with Excel Industries, Inc., manufacturer of Hustler® Turf Equipment, Inc mowers ("Manufacturer").

Any unauthorized modification, alteration, or use of non-approved attachments voids the warranty and releases Manufacturer from any liability arising from subsequent use of this equipment. Do not use or operate any attachment not approved by Hustler® Turf Equipment, Inc.

Damage caused by unauthorized replacement parts is not covered by this warranty. Manufacturer expressly excludes liability for defects or damage caused by such 'unauthorized' articles or service.

Model and Serial Number

Mower model and serial numbers are found on the serial identification plate.

These numbers are required when the unit is registered with Hustler® Turf Equipment. They will also assure you of the correct service parts when replacement becomes necessary.

Shown below is an example of a serial identification plate and how to interpret it. (illustration of serial number plate)

Parts and Service

Use only original Hustler® Mower replacement parts available from your local Hustler® Dealer. Use original Hustler® replacement parts, or parts that are equivalent in overall performance, that are available from your local Hustler® Dealer. For prompt, efficient service, always provide the following information when ordering parts: Correct part description. Correct part number. Correct model number. Correct serial number. All arrangements for warranty repair and service must be handled through an authorized Hustler® Dealer.

WARNING



This symbol points out important safety instructions which, if not followed, could endanger the personal safety and/or property of yourself and others. Read and follow all instructions in this manual before attempting to operate this machine. Failure to comply with these instructions may result in personal injury. When you see this symbol, HEED ITS WARNING!

DANGER

This machine was built to be operated according to the safe operation practices in this manual. As with any type of power equipment, carelessness, or error on the part of the operator can result in serious injury. This machine is capable of amputating hands and feet and throwing objects. Failure to observe the following safety instructions could result in serious injury or death.

Training

1. Read the Operator's Manual and other training material. If the operator(s) or mechanic(s) cannot read English it is the owner's responsibility to explain this material to them.
2. Become familiar with the safe operation of the machine, operator controls, and safety signs.
3. All operators and mechanics should be trained to operate or service the equipment. The owner is responsible for training them.
4. Never let children under the age of 16 or untrained people operate or service the equipment. Local regulations may further restrict the age of the operator.
5. The owner/operator can prevent, and is responsible for, accidents or injuries occurring to them, other people, or property.

General Operation

1. Read, understand, and follow all instructions on the machine and in the manual(s) before attempting to assemble and operate. Keep this manual in a safe place for future and regular reference by each operator and for ordering replacement parts.
2. Be familiar with all controls and their proper operation. Know how to stop the machine and disengage the controls quickly.
3. Do not allow anyone to operate or maintain this machine who has not read the manual. Never permit children under the age of 16 to operate this machine.
4. Do not remove any shields, guards, labels, or safety devices. If a shield, guard, label, or safety device is damaged or does not function, repair or replace it before operating the machine.
5. To help avoid blade contact or a thrown object injury, keep bystanders, helpers, children, and pets at least 75 feet (23 meters) from the machine while it is in operation. Stop machine if anyone enters the area.
6. Thoroughly inspect the area where the equipment is to be used. Remove all stones, sticks, wire, bones, toys, and other foreign objects that could be picked up and thrown by the blade(s). Thrown objects can cause serious personal injury.
7. Evaluate the terrain to determine what accessories and attachments are needed to properly and safely perform the job. Only use accessories and attachments approved by the machine manufacturer.
8. Plan your mowing pattern to avoid discharge of material toward roads, sidewalks, bystanders, and the like. Also, avoid discharging material against a wall or obstruction which may cause discharged material to ricochet back toward the operator.
9. Always wear appropriate clothing and personal protective equipment (e.g. safety glasses, long pants, gloves, hearing

- protection, safety shoes, hard hat) when operating or maintaining this machine. Long hair, loose fitting clothing, or jewelry may get entangled in moving parts. Follow all federal, state, and local guidelines regarding the use of personal protective equipment.
10. For extended use of this product, hearing protection is recommended.
11. Be aware of the mower and attachment discharge direction and do not point it at anyone. Do not operate the mower without the discharge cover or entire grass catcher in its proper place.
12. Do not put hands or feet near rotating parts or under the cutting deck. Contact with the blade(s) can amputate hands and feet.
13. A missing or damaged discharge cover can cause blade contact or thrown object injuries.
14. Stop the blade(s) when crossing gravel drives, walks, or roads and while not cutting grass.
15. Watch for traffic when operating near or crossing roadways. This machine is not intended for use on any public roadway.
16. Do not operate the machine while under the influence of alcohol or drugs.
17. Mow only in daylight or good artificial light.
18. Never carry passengers.
19. Back up slowly. Always look down and behind before and while backing to avoid a back-over accident.
20. Slow down before turning. Operate the machine smoothly. Avoid erratic operation and excessive speed. Be aware of your direction of travel to avoid accidents.
21. Disengage blade(s), set parking brake, stop engine, and wait until the blade(s) come to a complete stop before removing grass catcher, emptying grass, unclogging chute, removing any grass or debris, or making any adjustments.
22. Never leave a running machine unattended. Always stop on level ground, turn off blade(s), place drive control levers in neutral, set parking brake, stop engine, and remove key before leaving the operator position.
23. Use extra care when loading or unloading the machine on a trailer or truck. The machine should not be driven on unstable, unsecured, or inadequate ramps because the machine could tip over causing serious personal injury.
24. Check overhead clearances carefully before driving under low hanging tree branches, wires, door openings, etc., where the operator and/or ROPS may be struck which could result in serious injury and/or machine tip over.
25. Muffler and engine become hot and can cause a burn. Do not touch.
26. Disengage the blades, set the parking brake to the 'on' position, and make sure the drive control levers are in the

SAFE OPERATION PRACTICES

- neutral position before attempting to start the engine. Only start the engine from the operator's position.
27. Do not attempt to mow unusually tall, dry grass (e.g., pasture) or piles of dry leaves. Dry grass or leaves may contact the engine exhaust and/or build up on the mower deck presenting a potential fire hazard.
 28. Do not stop or park the machine over dry leaves, grass, debris, or other combustible material.
 29. Never attempt to operate the machine without the mowing deck attached; the machine could tip over.
 30. Keep the machine and especially the engine exhaust system and hydraulic components clean and free of grease, grass, and leaves to reduce the potential for overheating and fire.
 31. Allow the machine to cool at least 5 minutes before storing.
 32. Use only accessories and attachments approved for this machine by the machine manufacturer. Read, understand, and follow all instructions provided with the approved accessory or attachment.
 33. Data indicates that operators, age 65 years and above, are involved in a large percentage of mower-related injuries. Operators should evaluate their ability to operate this machine safely enough to protect themselves and others from serious injury.
 34. Do not operate or start machine if there are fuel or oil leaks; repair immediately.
 35. When looking for oil leaks, never run your hand over hydraulic hoses, lines, or fittings. Never tighten or adjust hydraulic hoses, lines, or fittings while the system is under pressure. If high-pressure oil penetrates the skin seek immediate medical attention or gangrene and permanent damage may result. Do not check for hydraulic leaks with your hands, use paper or cardboard instead. Wear gloves and safety glasses when checking for leaks.
 36. Do not operate machines that have been damaged or have not been properly maintained. If the machine has been damaged, have it repaired.
 37. When operating this machine in the forward direction, do not allow the drive control levers to return to the neutral position on their own. Always operate them smoothly and avoid any sudden movements of the levers when starting or stopping.
 38. If situations occur which are not covered in this manual use care and good judgement. Contact your customer service representative for assistance.
3. Use slow speed. Choose a low enough speed so that you will not have to stop while on the slope. Avoid starting or stopping on a slope. If the tires are unable to maintain traction, disengage the blades and proceed slowly and carefully straight down the slope.
 4. Keep all movements on slopes slow and gradual. Do not make sudden changes in speed or direction. Rapid acceleration could cause the front of the machine to lift and rapidly flip over backwards, which could cause serious injury or death.
 5. Follow the manufacturer's recommendations for wheel weights or counterweights to improve stability.
 6. Use extra care with grass catchers or other attachments. These can change the stability of the machine.

Do Not:

1. Do not turn on slopes unless necessary; then turn slowly uphill and use extra care while turning.
2. Do not mow near drop-offs, ditches, or embankments. The machine could suddenly turn over if a wheel is over the edge of a cliff, ditch, or if an edge caves in.
3. Do not operate on slopes or near the edge of water such as a lake, pond, river, or stream where the machine could slip, tip, or roll-over into the water.
4. Do not try to stabilize the machine by putting your foot on the ground.
5. Use extra care while operating mower with grass catcher or other attachment(s). They can affect the stability of the mower. Do not use grass catcher on slopes greater than 10° (17%).
6. Do not mow on wet grass. Reduced traction could cause sliding and/or loss of control.
7. Do not tow heavy pull behind attachments (e.g. loaded dump cart, lawn roller, etc.) on slopes greater than 5° (9%). When going downhill, the extra weight tends to push the machine and may cause loss of traction and loss of control (e.g. machine may speed up, braking and steering ability are reduced, attachment may jack-knife and cause machine to overturn).

Slope gauge (back cover)

⚠ WARNING

Slopes are a major factor related to slip and fall accidents which can result in severe injury or death. All slopes require extra caution. If you feel uneasy on the slope, do not mow it. Do not mow on slopes greater than 15° (26%). Do not mow up and down slopes, only mow across slopes

USE THE SLOPE GAUGE ON THE BACK COVER AS SHOWN TO DETERMINE IF A SLOPE IS TOO STEEP FOR SAFE OPERATION!

To check the slope, proceed as follows:

1. Open manual to the back cover and fold along the dashed line.
2. Locate a vertical object on or behind the slope (e.g., a pole, building, fence, tree, etc.).
3. Align either side of the slope gauge with the object.
4. Adjust gauge up or down until the left corner touches the slope.
5. If there is a gap below the gauge, the slope is too steep for safe operation.

Children

1. Tragic accidents can occur if the operator is not alert to the presence of children. Children are often attracted to the

Slope Operation

Slopes are a major factor related to loss of control and tip-over accidents that can result in severe injury or death. All slopes require extra caution. If you cannot back up the slope or if you feel uneasy on it, do not mow it or drive on the slope.

For your safety, use the slope gauge included as part of this manual to measure slopes before operating this machine on a sloped or hilly area. If the slope is greater than 15° (26%) as shown on the slope gauge, do not operate this machine on that area or serious injury could result.

Do:

1. Mow across slopes, not up and down. Exercise extreme caution when changing direction on slopes.
2. Watch for holes, ruts, bumps, rocks, or other hidden objects. Uneven terrain could overturn the machine. Tall grass can hide obstacles.

SAFE OPERATION PRACTICES

- machine and the mowing activity. They do not understand the dangers. Never assume that children will remain where you last saw them.
- Keep children out of the mowing area and in watchful care of a responsible adult other than the operator.
 - Be alert and turn machine off if a child enters the area.
 - Always look behind and down for small children. Use slow speed.
 - Never carry children, even with the blade(s) shut off. They may fall off or interfere with safe mower operation, causing serious injury or death.
 - Use extreme care when approaching blind corners, doorways, shrubs, trees, or other objects that may block your vision of a child who may run into the path of the machine.
 - To avoid back-over accidents, always disengage blades before traveling in reverse.
 - Keep children away from hot or running engines. They can suffer burns from a hot muffler.
 - Remove key when machine is unattended to prevent unauthorized operation.
2. Never allow children under 16 years of age to operate this machine. Children 16 and over should read and understand the instructions and safe operation practices in this manual and on the machine and should be trained and supervised by an adult

Towing

1. Do not tow heavy tow-behind attachments (e.g. loaded dump cart, lawn roller, etc.) on slopes greater than 5° (9%).
2. Tow only with a machine that has a hitch designed for towing. Do not attach towed equipment except at the hitch point.
3. Follow the manufacturer's recommendation for weight limits for towed equipment and towing on slopes.
4. Never allow children or others in or on towed equipment.
5. On slopes, the weight of the towed equipment may cause loss of traction and loss of control.
6. Travel slowly and allow extra distance to stop.
7. Make wide turns to avoid jack knifing.

Transporting Machines

1. This machine is not intended for use on public roads. Machines operated on public roads must comply with state and local ordinances, SAE J137, and ANSI/ASABE S279 (lighting and marking requirements).
2. Use care when loading or unloading machines onto trailers and trucks.
3. If ramps are used, they must be full width, stable, have an adequate capacity rating, and be secured to the trailer or truck. Ramp angle should not exceed 15° (26%) and trailer or truck should be parked on level terrain.
4. Machines must be secured onto trailers and trucks with straps, chains, cables, ropes, or other means deemed adequate for that purpose. The front and rear of the machines must be secured to the trailer or truck in both the lateral and vertical directions.

Operator Protective System (OPS)

1. This machine is equipped with an Operator Protective System (OPS), which includes:

- A Roll Over Protective Structure (ROPS) of the fixed or folding configuration.
 - Seat belt assembly with retractable function.
2. ROPS are structures designed to provide a crush-resistant space for the operator when properly seat-belted within the designated seating area of the machine in the event of a machine tip-over or roll-over. Folding ROPS shall be used in their fully upright and locked configurations except in those circumstances whereby they need to be momentarily folded-down to avoid contact with items such as tree limbs, clothes lines, guy wires, utility poles, buildings, etc. At other times and conditions, ROPS shall be in their fully upright and locked configurations.

⚠ DANGER

Damaged ROPS must be replaced prior to operator use.

3. Seat belts shall be used and shall be properly fastened about the operator's waist at all times, except when the ROPS are:
 - Not properly installed and/or not properly secured onto the machine.
 - Damaged in such manner that their structural integrity has been compromised.
 - Not in their fully upright and locked position.
4. Seat belts are attached to the movable portion of the seat when suspension seats are utilized, and therefore the seat-mounting base must be secured to its pivot means and the pivot means latched to the frame of the machine. Seat belts are attached to the seat or the frame of the machine when non-suspension (standard) seats are provided, however, if a suspension kit is added to a seat, the seat belt must be attached to the movable portion of the seat or suspension mechanism, the seat-mounting base must be secured to its pivot means, and the pivot means be latched to the frame of the machine.

⚠ DANGER

If ROPS are folded down or missing, seat belts shall not be fastened. Worn or damaged seat belt assemblies must be replaced prior to operator use.

5. A brush guard or canopy may deflect tree limbs, clothes lines, and other obstacles that otherwise could come in contact with the ROPS. Contact of ROPS and/or canopies by items such as tree limbs, clothes lines, guy wires, and buildings, could create hazardous conditions whereby the machine could experience a tip-over or roll-over. A canopy may provide protection for the operator from some environmental exposure (sunlight, rain, etc.).
6. The ROPS and seat belt are integral parts of this machine and should not be tampered with, modified in any manner, or removed.
7. Inspect the ROPS and seat belt assemblies on a regular basis for damage and improper operation. Replace all components that are damaged or are not functioning properly with authorized replacement parts.
8. The ROPS extends above and behind the operator position, and therefore the operator must be aware of potential contact of the ROPS with items such as trees, buildings, doorways, clothes lines, utility wires, etc., that could cause the machine to tip-over or rollover. Use caution in (or avoid) areas where the ROPS could come in contact with any structures, trees, etc.

9. Inspect the ROPS and seat belt assemblies on a regular basis for damage and improper operation. Replace all components that are damaged or are not functioning properly with authorized replacement parts.
10. Failure to use the seat belt properly could result in serious injury or death if an accidental overturn occurs. In order for the ROPS to be effective, the seat belt must be securely fastened around the operator at all times when the operator is on the machine. Contact with the ROPS during an overturn could cause serious injury or death.
11. The ROPS will not prevent machine from tip-overs or roll-overs.
12. Do not assume ROPS will protect you in a tip-over or roll-over. Injuries may still occur.

Hydraulic Devices and Systems

Hydraulic fluid escaping under pressure may have sufficient force to penetrate skin and cause serious injury. If foreign fluid is injected into the skin or eyes, seek immediate medical attention or gangrene and permanent damage may result.

⚠ WARNING

Keep body and hands away from pinholes or nozzles that could inject hydraulic fluid under high pressure. Use paper or cardboard, not your hands, to search for leaks! Wear gloves and safety glasses.

Safely relieve all pressure in the system before performing any work on the system, and make sure that:

- The ignition switch is OFF.
- The key is removed.
- The engine spark plug wire(s) is removed.
- All connections to the negative terminal of the battery are removed.
- The park brake is set.
- All by-pass valves, if so equipped, are open.
- Hydraulic controls are actuated to release pressure on pumps, cylinders, etc. If "float" positions are available, they should be used.

After the above operations are completed, it should be safe to begin disconnecting the lines or components. It is still a good idea to cover the connection with a cloth shield and then gently loosen connections.

⚠ WARNING

Make sure all hydraulic fluid connections are tight and all hydraulic hoses and lines are in good condition before applying pressure to the system.

Service

Safe Handling of Fuel

To avoid personal injury or property damage use extreme care in handling fuel. Fuel is extremely flammable and the vapors are explosive. Serious personal injury can occur when fuel is spilled on yourself or your clothes, which can ignite. Wash your skin and change your clothes immediately.

- Use only approved containers.
- Never fill containers inside a vehicle or a truck or trailer bed with a carpeted or plastic liner. Always place containers on the ground away from your vehicle before fueling.

- When practical, remove machine from the truck or trailer and refuel it on the ground. If this is not possible, then refuel equipment on a trailer with a portable container rather than from a fuel dispenser nozzle.
- Keep nozzle in contact with the rim of the fuel tank or container opening at all times until fueling is complete. Do not use a nozzle lock-open device.
- Extinguish all cigarettes, cigars, pipes, and other sources of ignition.
- Never fuel machine indoors or near ignition sources.
- Never remove fuel cap or add fuel while the engine is hot or running. Allow engine to cool at least 5 minutes before refueling.
- Never over fill fuel tank. Fill tank to no more than 1/2" below bottom of filler neck to allow space for expansion.
- If necessary, use a funnel to avoid spillage.
- Replace fuel cap and tighten securely.
- If fuel is spilled, wipe off the engine and equipment. Wait 5 minutes before starting the engine.
- To reduce fire hazards, keep machine free of grass, leaves, or other debris build-up. Clean up oil and fuel spillage and remove any fuel-soaked debris.
- Never store the machine or fuel container inside where there is an open flame, spark, or pilot light as on a water heater, space heater, furnace, clothes dryer, or other gas appliance

General Service

1. Never run an engine indoors or in a poorly ventilated area. Engine exhaust contains carbon monoxide, an odorless and deadly gas.
2. Before cleaning, repairing, or inspecting, make certain the blade(s) and all moving parts have stopped. Disconnect the spark plug wires and remove the key from the ignition to prevent unintended starting.
3. Periodically check to make sure the blades come to a complete stop within approximately 7 seconds after operating the blade disengagement control. If the blades do not stop within this time frame, your machine should be serviced.
4. Never tamper with the safety interlock system or other safety devices.
5. Regularly check the safety interlock system for proper function, as described later in this manual. If the safety interlock system does not function properly, have your machine serviced.
6. Check brake operation frequently as it is subjected to wear during normal operation. Adjust and service as required.
7. Check the blade(s) and engine mounting bolts at frequent intervals for proper tightness. Also, visually inspect blade(s) for damage (e.g., excessive wear, bent, cracked). Replace the blade(s) with the original equipment manufacturer's (O.E.M.) blade(s) only, listed in this manual. Use of parts which do not meet the original equipment specifications may lead to improper performance and compromise safety!
8. Mower blades are sharp. Wrap the blade or wear gloves, and use extra caution when servicing them.
9. Keep all nuts, bolts, and screws tight to be sure the equipment is in safe working condition.
10. After striking a foreign object (or if abnormal vibration occurs), stop the blades and engine and thoroughly inspect the machine for any damage. Make necessary repairs before resuming operation.







11. Never attempt to make adjustments or repairs to the machine while the engine is running.
12. Grass catcher components and the discharge cover are subject to wear and damage which could expose moving parts or allow objects to be thrown. For safety protection, frequently check components and replace immediately with original equipment manufacturer's (O.E.M.) parts only, listed in this manual. Use of parts which do not meet the original equipment specifications may lead to improper performance and compromise safety!
13. Do not change the engine governor settings or over-speed the engine. The governor controls the maximum safe operating speed of the engine.
14. Maintain or replace safety and instruction labels, as necessary.
15. Observe proper disposal laws and regulations for gas, oil, etc., to protect the environment.



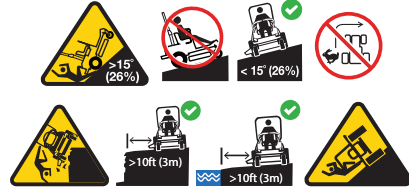

Do Not Modify Engine

To avoid serious injury or death, do not modify engine in any way. Tampering with the governor setting can lead to a runaway engine and cause it to operate at unsafe speeds. Never tamper with factory setting of engine governor.

Safety Symbols

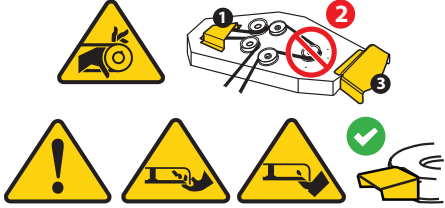
This table depicts and describes safety symbols that may appear on this product. Read, understand, and follow all instructions on the machine before attempting to assemble and operate.

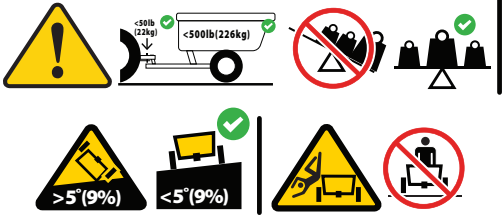
Symbol	Description
 <p>OPESymbol.com</p>	<p>WARNING - READ OPERATOR'S MANUAL - Read, understand, and follow all the safety rules and instructions in the manual(s) and on the mower before attempting to operate this mower. Failure to comply with this information may result in personal injury or death. Keep this manual in a safe location for future and regular reference. Using a Smart Phone, scan the QR code symbol to learn more information concerning the warnings contained on this mower. You can also go to www.OPESymbol.com for more information.</p>
	<p>WARNING - TRAINING - Read the Operator's Manual and other training material. It is the owner's responsibility to provide training to operate or service the equipment.</p>
	<p>WARNING - AVOID THROWN OBJECTS INJURY - Keep helpers at least 75 feet (23 meters) from machine during operation. Remove all stones, sticks, wire, bones, toys, and other foreign objects which could be picked up and thrown by the blade(s). Do not operate the mower without the discharge cover or entire grass catcher in its proper place.</p>
	<p>WARNING - AVOID CHILD BACKOVER/RUNOVER/BLADE INJURY - To avoid back-over accidents, always look behind and down for small children. Never carry children, even with the blade(s) shut off. Keep bystanders, children, and pets inside during operation under the watchful care of a responsible adult other than the operator. Stop mower if anyone enters the area.</p>
	<p>WARNING - AVOID TIP-OVER/ROLL-OVER INJURY - Do not operate machine on a slope greater than 15° (26%). Do not mow up or down slopes, only mow across slopes that are less than 15° (26%). Use low speeds and avoid sudden turns on slopes. Stay at least 10 feet (3 meters) from drop-offs, ditches, embankments, or the edge of water.</p>
	<p>WARNING - AVOID FIRES - Your mower is designed to cut normal residential grass of a height no more than 10" (25 cm). Do not attempt to mow through unusually tall, dry grass (e.g., pasture), or piles of dry leaves. Allow mower to cool at least 5 minutes before fueling or storing inside an enclosed garage or storage shed.</p>

Symbol	Description
	<p>WARNING - AVOID AMPUTATION INJURY - Do not put hands or feet near rotating parts or under the cutting deck. Contact with the blade(s) can amputate hands and feet. Ensure that all safety devices (guards, shields, switches, etc.) are in place and working. Belt and/or blade spindle contact can crush or injure body parts.</p>
	<p>WARNING - REMOVE KEY - Always turn off blade(s), move the drive control levers outward into park position, stop engine, and remove key before dismounting. If you are leaving the mower unattended, always remove the key to prevent unauthorized use by children or others.</p>
	<p>WARNING - AVOID TOWING RELATED INJURY - Do not tow a load that exceeds 500 lbs (226 kg) rolling weight and never exceed 50 lbs (22 kg) tongue weight. Never allow children or others in or on towed equipment. Do not tow on slopes greater than 5° (9%). On slopes, the weight of the towed equipment may cause loss of traction, loss of control, and/or loss of the ability to stop. Travel slowly and allow extra distance to stop.</p>
	<p>WARNING - Avoid Serious Injury Or Death From Roll Over - Keep roll bar in the raised upright position with your seat belt fastened. Lower roll bar and do not fasten seat belt in low clearance situations. Raise roll bar and fasten seat belt as soon as clearance permits.</p>

⚠ WARNING

Your Responsibility—Restrict the use of this power machine to persons who read, understand, and follow the warnings and instructions in this manual and on the machine - **SAVE THESE INSTRUCTIONS!**

Operation Illustrations

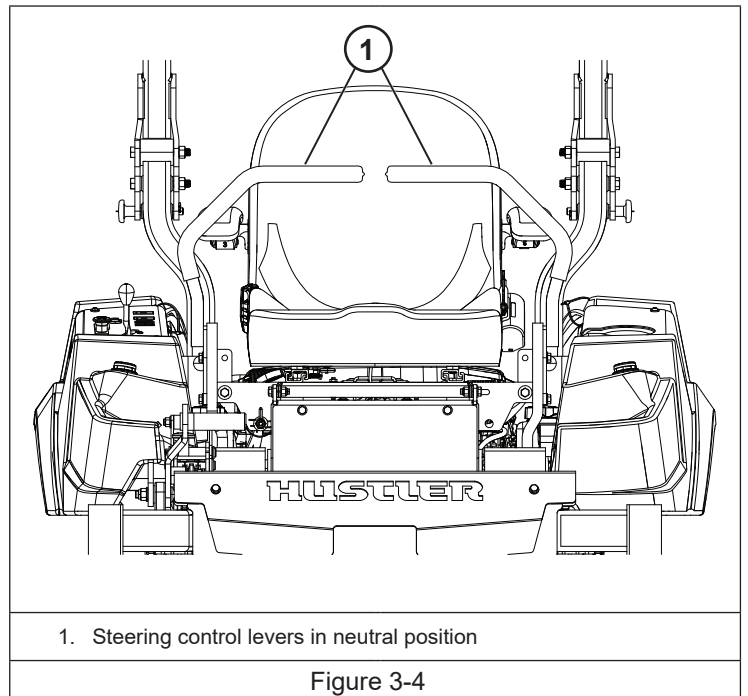
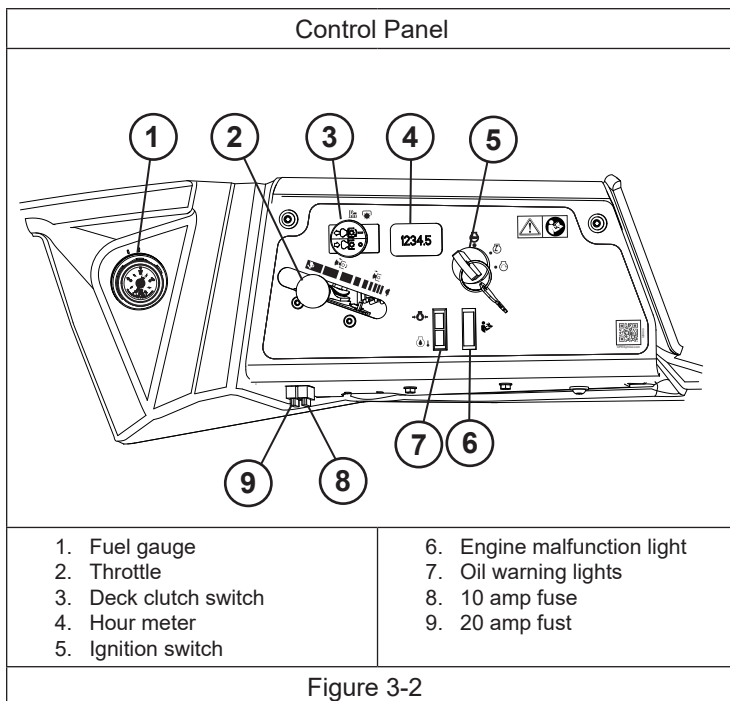
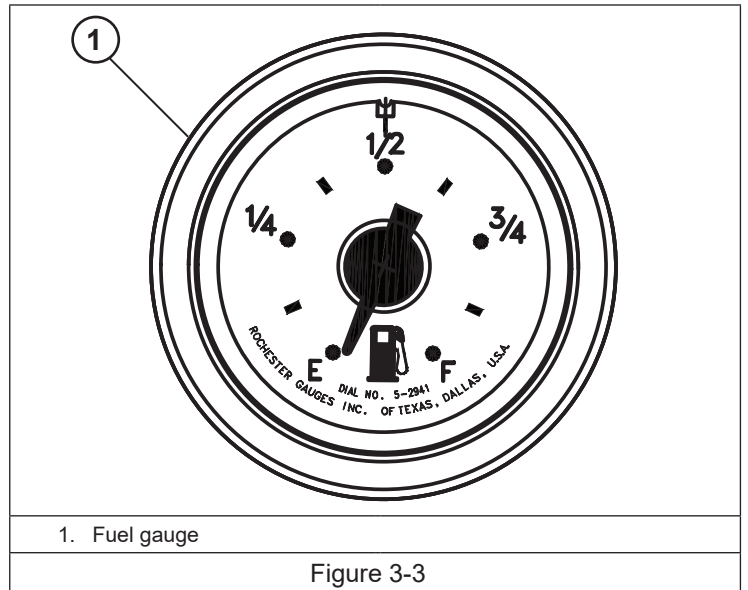
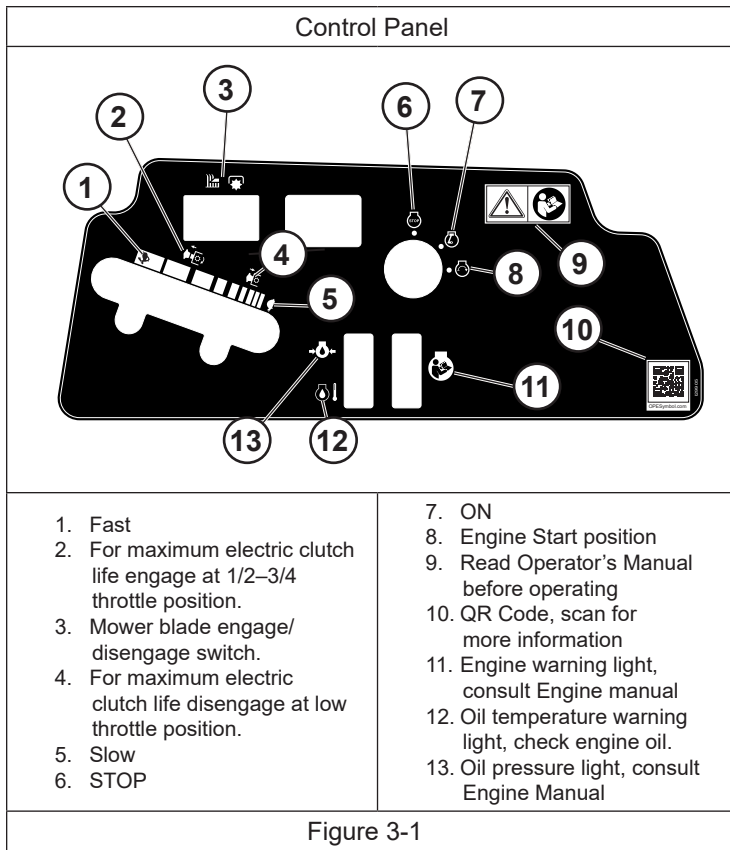

Shown with steering control levers in park brake position

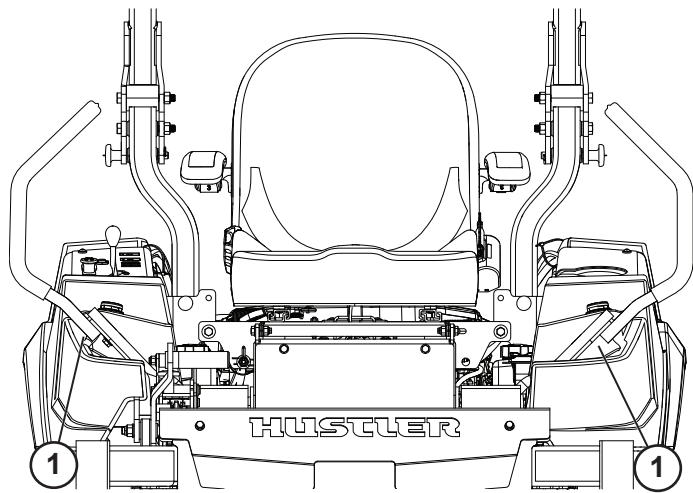

1. Steering control lever

Figure 3-5

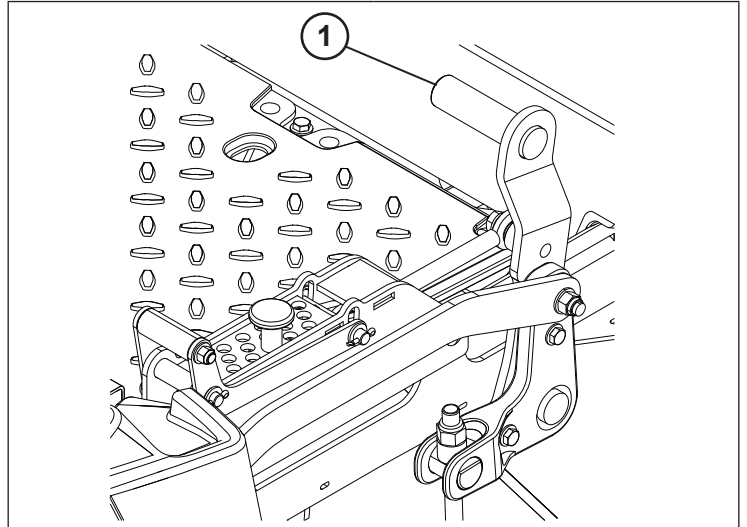

1. Deck lift pedal

Figure 3-7

Steering Direction

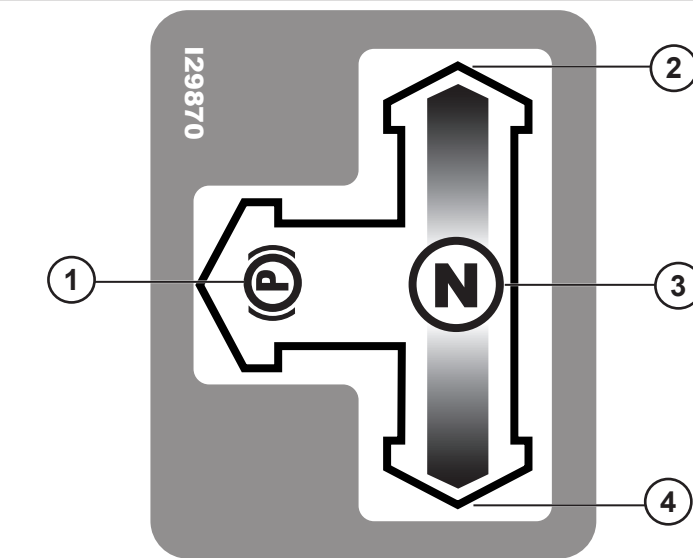

1. Park
2. Forward

3. Neutral
4. Reverse

Figure 3-6

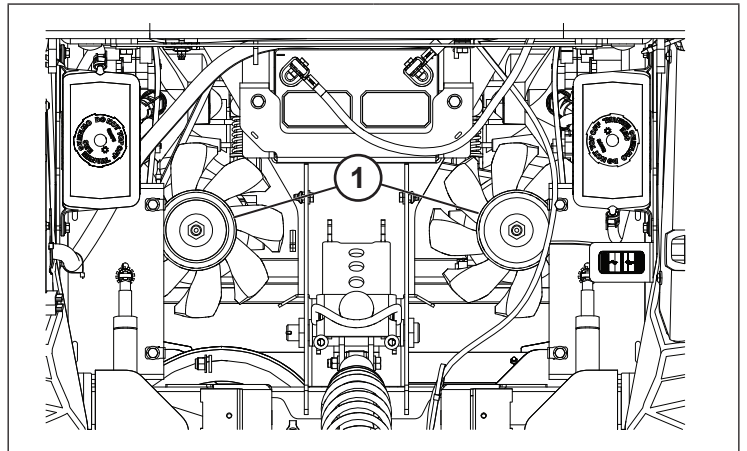

1. Integrated transmission

Figure 3-8

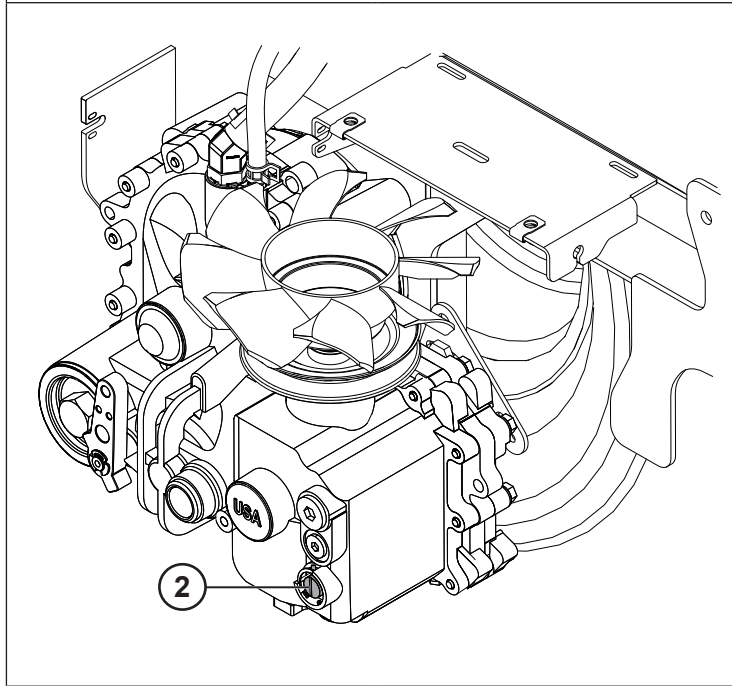
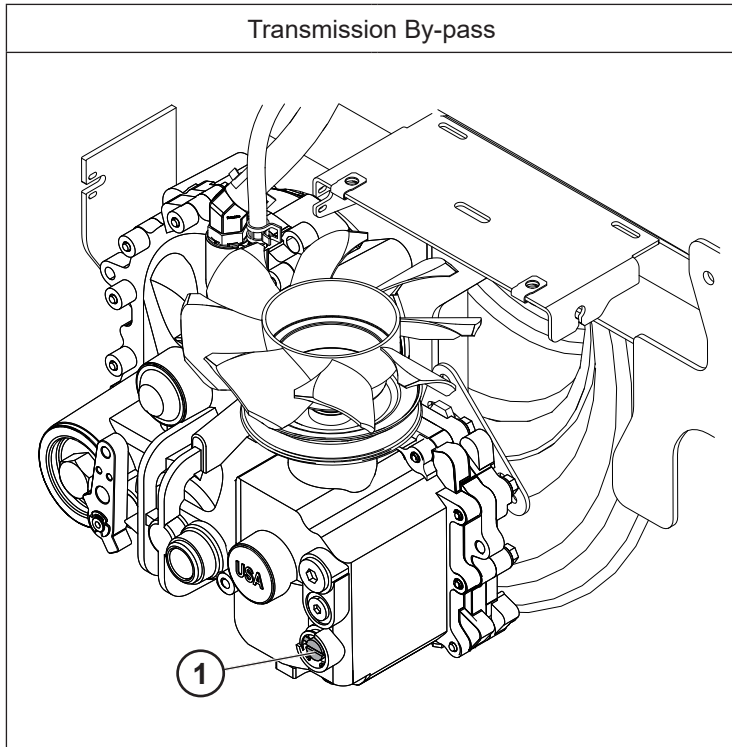

1. Closed	2. Open
-----------	---------

Figure 3-9

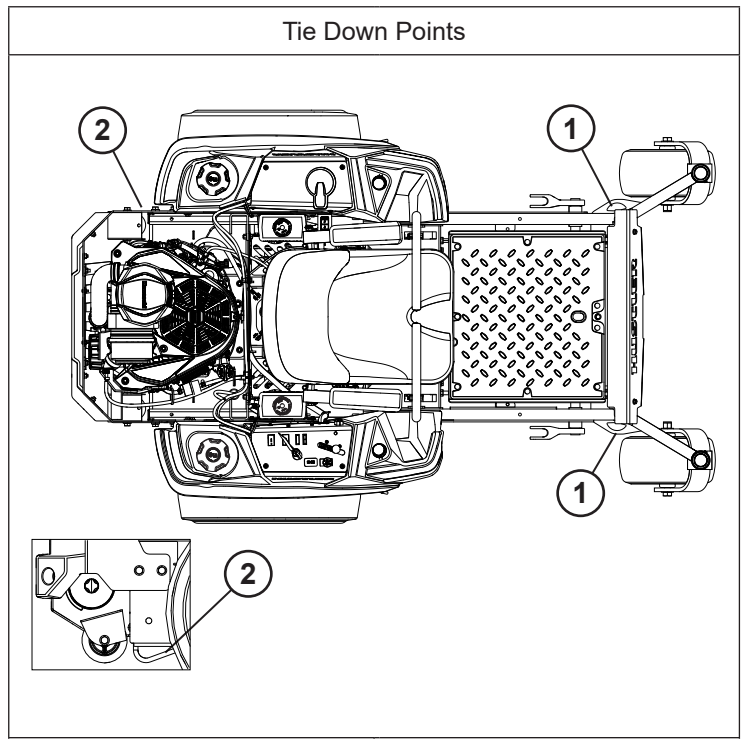

1. Tie down - Front	2. Tie down - Rear
---------------------	--------------------

Figure 3-10

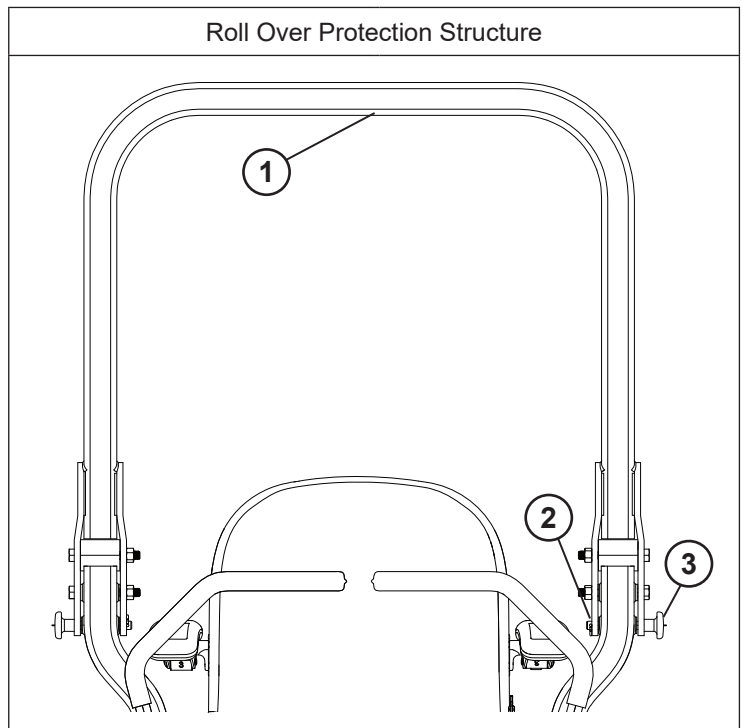

1. ROPS 2. Hair pin	3. Pin
------------------------	--------

Figure 3-11

Roll Over Protection Mount

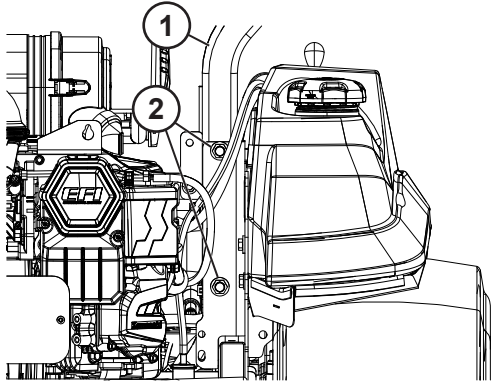

- | | |
|--------------|----------------------|
| 1. ROPS post | 2. Mounting hardware |
|--------------|----------------------|

Figure 3-12

VX4 Deck Configuration - Air Baffles

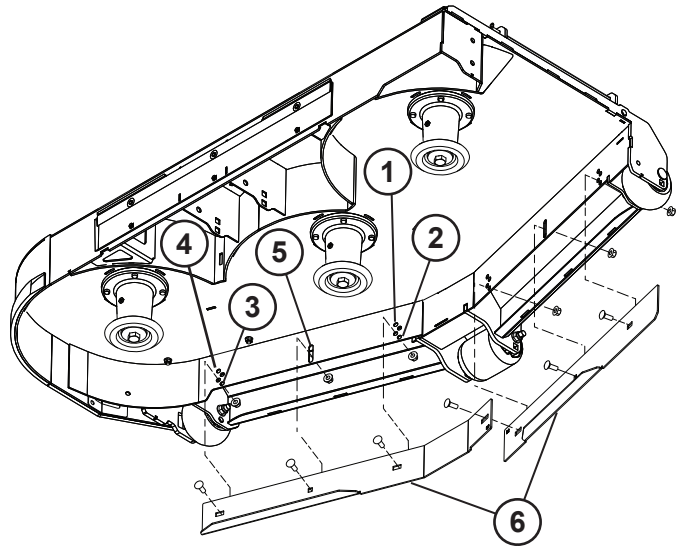

- | | |
|------------------------|---------------------|
| 1. Bottom set of holes | 4. Top set of holes |
| 2. 2nd set of holes | 5. Slot |
| 3. 3rd set of holes | 6. Baffles |

Figure 3-15

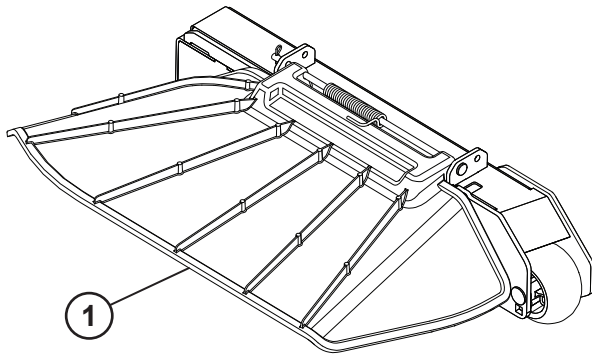

1. Discharge chute

Figure 3-13

Deck Height Adjustment

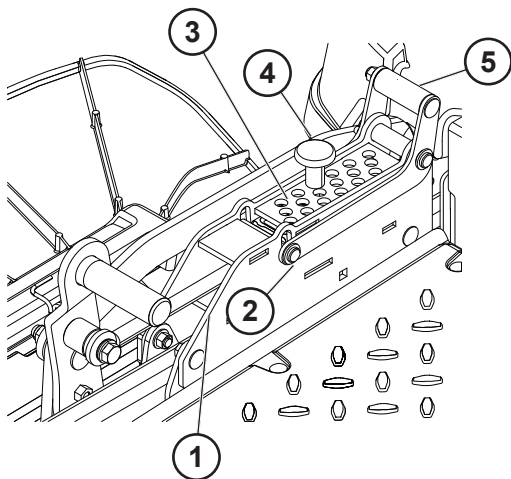

- | | |
|----------------------------------|---------------------------|
| 1. Cutting height adjustment bar | 4. Cutting height pin |
| 2. Transport lever pin | 5. Transport lever handle |
| 3. Cutting height holes | |

Figure 3-14

Anti-scalp Wheels

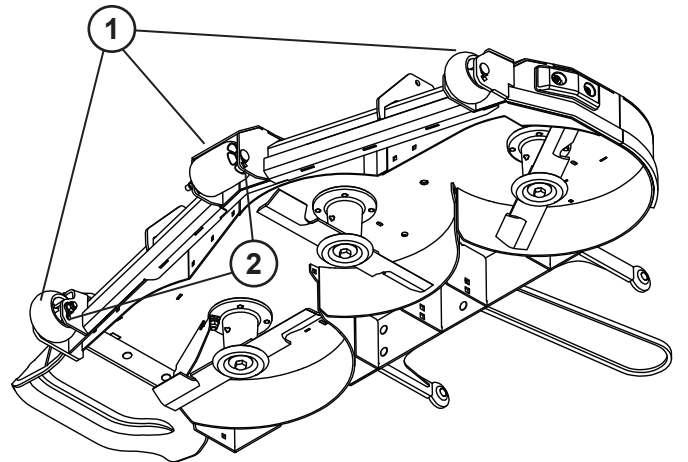

- | | |
|---------------------|--------------------|
| 1. Anti_scalp wheel | 2. Adjusting holes |
|---------------------|--------------------|

Figure 3-16

STEERING INSTRUCTIONS
FRONT OF MOWER FACES THIS DIRECTION

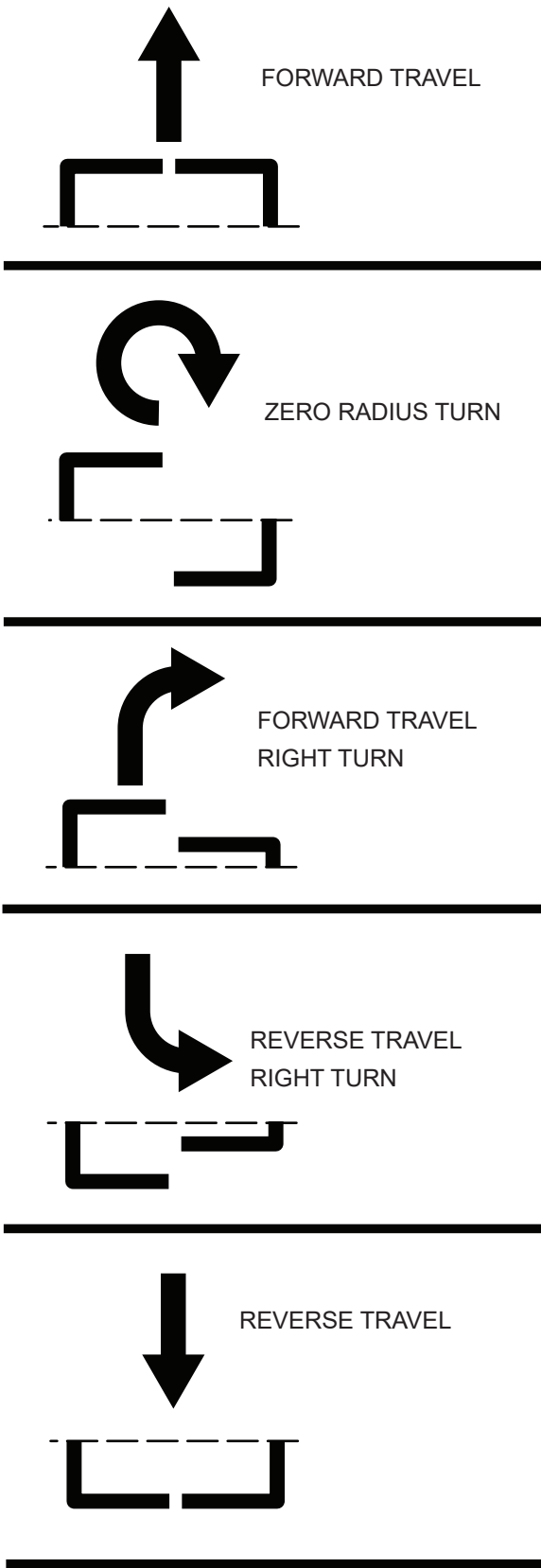

Figure 3-17

THREE POINT TURN

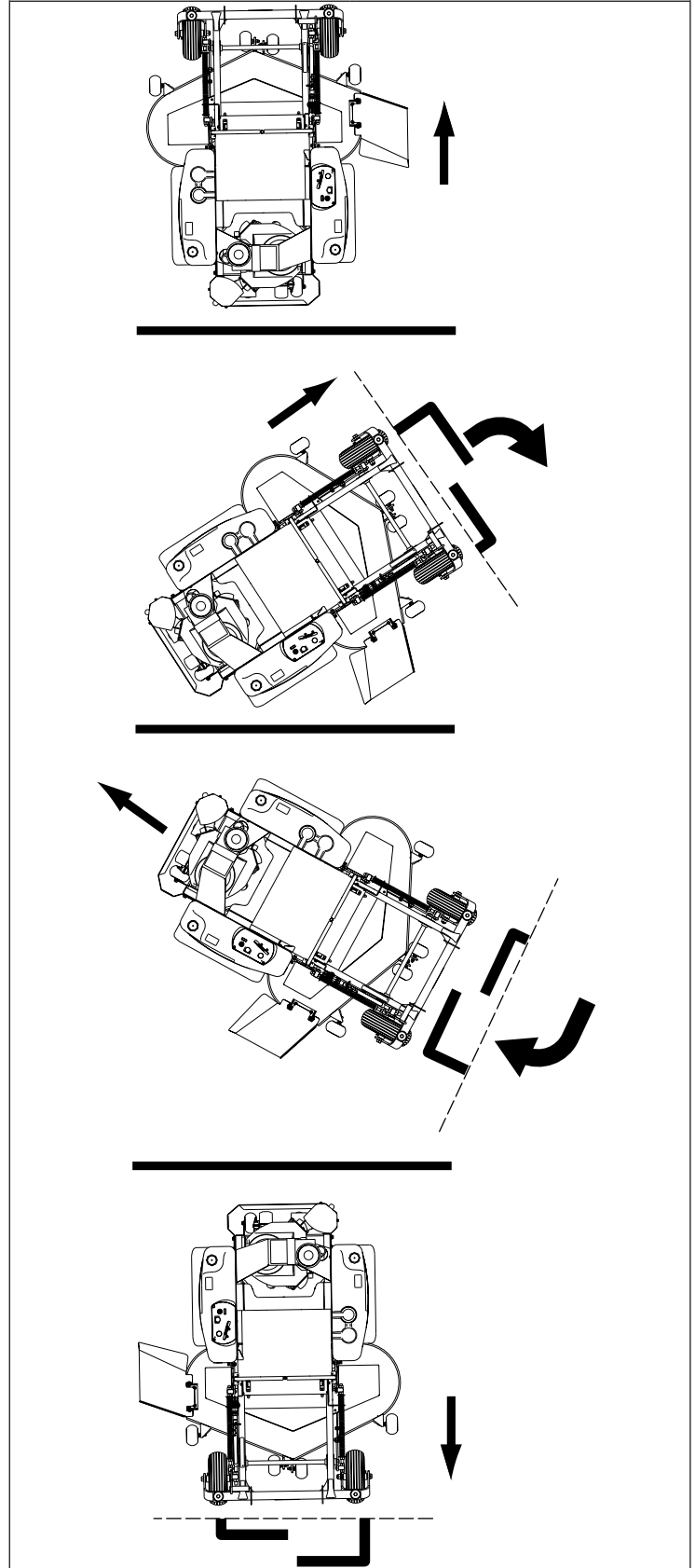

Figure 3-18

OPERATION

Safe Operating Practices

Refer to the Safety Precautions section of this manual for operational and personal safety information.

Control Panel

1. Fuel tank gauge (Figure 3-2 & Figure 3-3) — this gauge shows the fuel level for each fuel tank. There is one on each tank.
2. Throttle control (Figure 3-1 & Figure 3-2) — Move the lever forward to increase engine rpm, move the lever rearward to decrease engine rpm.
3. Deck clutch switch (Figure 3-1 & Figure 3-2) — this switch engages the deck. Pull the switch up to engage and push switch down to disengage the clutch. For additional clutch information refer to the Mower Deck Operation section of this manual.
4. Electronic hour meter (Figure 3-2) — registers 1/10 hour increments up to 9,999.9 total hours. It is connected to the ignition switch. It records the accumulative time while the ignition key is switched to the “RUN” position.
5. Ignition switch (Figure 3-1 & Figure 3-2) — a three position switch: “OFF”, “RUN”, and “START”. With key inserted, rotate it clockwise to the “START” position; release the key when the engine starts, and the switch will automatically return to the “RUN” position.
6. Engine malfunction light (Figure 3-2) — this light comes on when there has been an engine malfunction on mowers with electronic fuel injected engines. Refer to the engine owner’s manual for more details.
7. Oil pressure light (Figure 3-1 & Figure 3-2) — this light comes on when the ignition switch is placed in the “RUN” position and stays lit until the engine is running and a safe oil pressure is developed. If the light comes on during operation, shut the engine off immediately and locate and correct the problem.
8. Oil Temperature light (Figure 3-1 & Figure 3-2) - this light comes on when the oil temperature is too high. Refer to engine’s owner’s manual for more details.
9. 10 amp fuse (Figure 3-1 & Figure 3-2) — ignition system & safety system - 10 amp, blade-type.
10. 20 amp fuse (Figure 3-1 & Figure 3-2) — Controller - 20 amp, blade-type.

Controls

⚠ WARNING

The parking brake may not hold the mower if parked on a slope. Block the machine when parked on a slope

1. Steering control levers (Figure 3-4, Figure 3-5 & Figure 3-6) — these levers control the mower’s speed, direction, stopping, and park brake.
2. Deck lift pedal (Figure 3-7) — the deck lift pedal is used to raise or lower the deck. Push on the pedal to raise the deck and then place the adjusting pin into the desired cutting height hole. Release the pedal. Push the deck lift pedal to raise the deck when going over obstructions.

Safety Start Interlock System

The mower’s safety start interlock system consists of the park brake switches, seat switch, and deck clutch switch.

IMPORTANT: Repair this important safety feature immediately if it malfunctions.

This safety feature prevents mower runaway or accidental entanglement during operation.

Check the mower’s safety start interlock system daily, prior to operation.

To inspect the system:

1. Sit on the seat when testing the seat switch.
2. Set both steering control levers in the park brake position.
3. Start the engine and allow it to warm up to operating temperature.
4. With the deck clutch switch down and the steering control levers in the park brake position, slowly rise off of the seat. The engine should continue to run.
5. With the deck clutch switch up and/or the steering control levers in the neutral position, slowly rise off of the seat. The engine should stop.
6. If the engine fails to stop when:
 - the deck clutch switch is up, or
 - one or both of the steering control levers is in the up (out of neutral position), and
 - the operator is off the seat, then
 - check the function of the seat switch. Replace the seat switch if it is not operating properly (is not opening or closing) and if the cause can not be determined.

If you cannot locate the problem contact your Hustler® Dealer

⚠ WARNING

The safety interlock system should always function per steps 4 and 5. If it does not function properly, correct it immediately. Do not operate machine without a properly functioning seat safety switch

Engine Starting

The mower’s safety start interlock system is also designed to protect the operator and others from accidental injury due to unintentional engine starting. The engine starting motor will not engage until:

1. Steering control levers are in the park brake position.
2. Deck clutch switch is in the down (OFF) position.

⚠ WARNING

The safety interlock system must not be disconnected or bypassed. Doing so could cause the machine to operate unexpectedly resulting in personal injury

Start the engine by following these steps. If you encounter difficulty, contact your Hustler® Dealer.

1. Make sure the steering control levers are in the park brake position and the deck clutch switch is disengaged. Start the engine from the operator’s position only.
2. Use the choke, if the unit is equipped with one, when the engine is cold, or if a warm engine fails to start within 5 seconds of cranking. Avoid flooding by operating the engine without choking as soon as possible.
3. Set the throttle at approximately the 1/2 open position.
4. Insert the key in the ignition switch and rotate it clockwise to engage the starting motor. Release the key when the engine starts.

IMPORTANT: The engine starter should not be operated for periods longer than 30 seconds at a time. At least two minutes

OPERATION

between such cranking periods to protect the starter from overheating and burning-out.

5. As soon as the engine begins to run, check to make sure all engine warning lights are off. If not, stop the engine immediately and check for the cause.
6. Perform the test shown in the Safety Start Interlock System section to make sure the safety start interlock system operates properly.
7. Allow the engine to idle two minutes before advancing the throttle and/or engaging the deck clutch.

Stopping the Engine

Use the following procedure to shut the engine off.

1. Place the steering control levers in the park brake position.
2. Throttle the engine back to low idle, then disengage the deck clutch. Refer to the Mower Deck Operation section for more details.
3. Let the engine run at low idle for two minutes.
4. Rotate the ignition key counter-clockwise to the "OFF" position. Remove the key from the switch before leaving the mower.

Moving the Mower with Stalled Engine

If it becomes necessary to move the mower when the engine is inoperative, the integrated transmissions are equipped with bypass valves. Figure 3-7, Figure 3-8 & Figure 3-9 Before moving the unit, remove ignition key from mower. The by-pass is located on the front side of the transmission and is activated by rotating the valve body one quarter turn. The valve body in a horizontal position indicates it is in "run" mode. Vertical position indicates the hydraulics are in by-pass mode. The steering control levers must be placed in the neutral position, to release the park brakes, so that the mower can be moved.

Do not tow the machine. Move it by hand or use a winch to load on a trailer for transporting.

When transporting on another vehicle, the mower should be facing forward and it must be secured using the tie-down points. Figure 3-10

Always make sure the two bypass valves are returned to their operating position before running the mower following repairs.

ROPS (Roll Over Protective Structure)

A ROPS may minimize the chance of injury or death from rollover.

A ROPS, when used with a seat belt, is effective in reducing injuries during unit overturn accidents. Overturning the unit without a ROPS or without the ROPS locked in the raised position Figure 3-11 can result in serious injury or death.

Pivot the two-post ROPS down by removing the right and left hair pins Figure 3-11, and pulling out on the pins to allow the machine to operate under low hanging tree limbs or other obstructions.

NOTE: When the ROPS is locked in the raised position make sure the hair pins are inserted into the holes in the end of the pins.

Do not wear the seat belt when the ROPS is in the lowered position. Use the ROPS in the "folded" position only when absolutely necessary.

⚠ WARNING

Do not operate the mower with the ROPS folded down (lowered position) as a standard operating mode. A folded down ROPS does not provide rollover protection.

⚠ WARNING

Always wear your seat belt unless the mower is not equipped with a ROPS or if the ROPS is folded down. In this case, the seat belt should never be worn

⚠ WARNING

To minimize chance of injury or death from rollover:

- Keep ROPS in the raised and locked position and use the seat belt.
- Never operate the machine on a slope with the ROPS folded down (lowered position).
- There is no roll over protection when the ROPS is in the lowered position.
- Lower the ROPS only when absolutely necessary. Drive slowly and carefully. Raise the ROPS as soon as clearance permits. Read and follow slope operation instructions and warnings.
- Do not wear seat belt when the ROPS is in the lowered position or if it is not equipped with one.

⚠ WARNING

Do not attach chains or ropes to the ROPS for pulling purposes, as the machine can tip backwards.

Always pull from the mower hitch

Always fasten the seat belt during mower operation (mower equipped with a ROPS in the "raised/up" position).

Inspect the area prior to mowing for proper overhead clearance (tree limbs, guy wires, doorways, etc).

Do not contact any overhead object with the ROPS.

Seat Belt Maintenance

Inspect the seat belt system (all seat, seat belt parts, and seat platform) daily prior to mowing for signs of any damage. Replace any parts with signs of:

- cuts,
- fraying,
- extreme or unusual wear,
- significant discoloration due to UV exposure,
- dirt or stiffness,
- abrasion to the seat belt webbing,
- damage to the buckle, latch plate or hardware,
- any other problem.

Use soap and water to clean the seat belt. Do not use carbon tetrachloride, naphtha, or other chemical cleaning agents, as these will weaken the webbing. For the same reason, do not bleach or dye the webbing. Replace the seat belt if worn or damaged.

Possible Damage to ROPS

If the unit has rolled over or the ROPS has been in some other type of accident (such as hitting an overhead object during transport), replace the ROPS to retain the best protection.

Following an accident, check the ROPS, the operator's seat, the seat belt, seat belt mountings and seat platform for possible damage. Before operating the machine, replace all damaged parts.

IMPORTANT: Do not attempt to weld or straighten the ROPS.

⚠ WARNING

The ROPS structure's protective capability may be impaired by structural damage, overturn or alteration. Do not remove or alter any of the ROPS parts. Do not attempt to weld or straighten ROPS. Failure to adhere to these instructions could result in severe injury or death.

If the ROPS is replaced, make sure to use the proper hardware and apply the recommended torque values to the attaching bolts

ROPS Inspection

Inspect the ROPS after the first 20 hours of operation. Following the initial inspection, check the ROPS after every 500 hours of operation or every six months, whichever comes first.

1. Check the torque of the ROPS mounting bolts. Tighten the bolts to the correct torques as shown below if necessary. Figure 3-12 Inspect the operator's seat and the mounting parts for the seat belt. Tighten the bolts to the correct torque as shown below if necessary and replace parts that show wear or damage.
2. Check the seat platform to make sure it is secured properly. Adjust or repair it as necessary.

⚠ WARNING

Never operate the mower with the seat platform improperly secured. The seat platform must be securely latched to prevent seat from moving/tilting in the event of mower tipping or rollover

Torque values are given below:

	ft-lbs	N•m
ROPS mounting hardware.	73	99
Seat belt mounting hardware.	48	65

Mower Operation

This mower features the SmoothTrak™ steering system. The following provides you with detailed information on how to operate the mower efficiently.

Driving the Mower

⚠ DANGER

Never make sudden stops or reverse direction, especially when maneuvering on a slope. The steering is designed for sensitive response. Rapid movement of the control levers in either direction could result in a reaction of the mower that can cause serious injury.

After starting the engine, engage the steering control levers and steer as follows:

To go forward, push the steering control levers forward an equal distance. Figure 3-17

To go in reverse, pull the steering control levers rearward an equal distance. Figure 3-17

To turn left, move the right steering control lever farther forward from neutral than the left steering control lever.

To turn right, move the left steering control lever farther forward from neutral than the right steering control lever. Figure 3-17

Zero radius turn, move one steering control lever forward and the other steering control lever back of neutral. This allows the drive wheels to counter-rotate. Figure 3-17

To stop or decrease speed, move steering control levers to neutral. When going forward pull back gently on steering control levers. When going in reverse push forward gently on steering control levers.

For emergency stops, when traveling forward or rearward, place the steering control levers in the park brake position immediately

⚠ DANGER

When moving in the rearward direction push forward gently on steering control levers and avoid sudden movement. Any sudden movement could cause the front of the mower to come off of the ground resulting in possible loss of control, causing serious injury or death.

To make a three point turn to the right:

1. Move the left steering control lever farther forward from neutral than the right steering control lever and start the turn. Figure 3-18
2. Next, pull back on the steering control levers until they pass neutral and the machine starts to go rearward. Figure 3-18
3. Pull the right steering control lever farther rearward from neutral than the left steering control lever until the rear of the machine pivots around. Figure 3-18
4. Then, push the steering control levers forward until they both pass neutral and the machine starts to go forward. Figure 3-18
5. Push the left steering control lever farther forward from neutral than the right steering control lever and finish the turn. Figure 3-18

⚠ DANGER

Always be aware of what is behind the machine before backing up. Do not mow in reverse unless absolutely necessary. Always look down and behind before and while backing up

IMPORTANT: Damage to the hydraulic system components may occur with rapid movement of the steering controls.

To increase speed, increase the steering control lever's distance from neutral. The farther forward the steering control levers are from neutral, the faster the mower will travel forward. The farther back the steering control levers are from neutral, the faster the mower will go in reverse.

Operating Suggestions

⚠ WARNING

An inexperienced operator should not mow on slopes or on uneven terrain.

Before attempting normal speed operation an inexperienced operator should: • be thoroughly familiar with the proper use and operation of the equipment, • read the manual completely and thoroughly, • have attempted slow moving maneuvers

⚠ WARNING

If you lose steering control while operating the machine, place the steering control levers in the park brake position immediately. Inspect the machine and involve your Hustler® Dealer to resolve the problem before continuing to operate

⚠ WARNING

The unit's steering control levers are very responsive: Easy does it! For smooth operation, move the levers slowly, avoiding sudden movement. Skill and ease of operation come with practice and experience. The machine can spin very rapidly. Use caution when making turns and slow down before making sharp turns.

⚠ WARNING

Sharp depressions or raised obstacles (such as gutters or curbs) should not be directly approached at high speed in an attempt to "jump" them as the operator could be thrown from the equipment. Approach at a slow speed and angle one drive wheel at the obstruction. Continue at an angle until the wheel clears and then pivot the opposite wheel around.

Inexperienced operators may have a tendency to oversteer and lose control. Practice slow maneuvers at low engine rpm (idle) on a flat open area before attempting normal speed operation.

When turning on soft wet turf, keep both wheels rolling either forward or backward. Pivoting on one stopped wheel can damage turf, especially when mowing.

Set the throttle at full rpm for maximum performance. This gives maximum power to the drive wheels and deck when needed. The throttle setting directly controls blade speed. Use the control levers to control ground speed rather than engine rpm.

Keep blades sharp. Many problems with incorrect cutting patterns are due to dull blades or blades which have been sharpened incorrectly. Information on sharpening blades is listed in this manual's maintenance section. Blade sharpness should be checked daily.

⚠ WARNING

Never work with blades while the engine is running or deck clutch switch is engaged (on).

Always place the deck clutch switch in the disengaged position, place steering control levers in the park brake position, turn the engine off and disconnect the negative battery cable.

Block the mower up when you must work under it.

Wear gloves when handling blades.

Always check for blade damage if the mower strikes a rock, branch or other foreign object during mowing!

SIDE DISCHARGE DECK – Direct grass discharge to the right, away from the unmowed area. Generally, this means using a pattern of left turns. Avoid throwing grass discharge onto unmowed area. Mowing clippings puts an unnecessary load on the unit and reduces mowing efficiency.

When mowing a lawn for the first time cut grass slightly longer than normal to avoid scalping uneven terrain. When cutting grass taller than six inches, you may want to mow the lawn twice to achieve a better quality of cut.

During normal mowing cut only about 1/3 of the grass blade.

Alternate the mowing direction to keep the grass growing straight and for better dispersion of the clippings.

Remember, grass grows at different rates at different times of the year. Mow more often in the early spring to maintain the same cutting height. As the growth rate slows in midsummer, mow

less frequently. If you cannot mow at a regular interval, mow at a high cutting height; then mow again two days later at a lower cutting height.

Raise the cutting height of the mower if the cutting width of the mower is wider than the previous mower. This ensures that uneven turf is not cut too short.

Raise the cutting height of the mower if the grass is slightly taller than normal or if it contains a high degree of moisture. Then mow it again with the cutting height set lower.

If the machine's forward motion must be stopped while mowing, a clump of grass clippings may drop onto your lawn. To avoid this, move onto a previously cut area with the blades engaged.

⚠ DANGER

Side Discharge Decks – Never direct the discharge of material from the mower deck toward bystanders. Never operate the mower deck with the discharge chute damaged, altered, removed, or in the raised position, except when the entire grass catcher attachment or mulching system is being used. Figure 3-13

⚠ DANGER

Never attempt to make any adjustments to the mower deck while the engine is running or with the deck drive clutch engaged. Mower blades cannot be seen and are located very close to the deck housing. Fingers and toes can be cut off instantly

Flex Forks

New Flex Forks® require a brief break-in period. Refer to the Maintenance and Adjustments section of this manual for more details.

Deck Clutch Operation

Before beginning operation, check to make sure the deck clutch switch is engaging and disengaging the blades properly.

⚠ WARNING

Make sure that the area around and under the deck is clear and that there are no bystanders in the immediate area before proceeding

To check the deck clutch switch:

1. Start the engine and engage the deck clutch.
2. With the deck clutch switch up (clutch engaged) and the engine running, listen to confirm that the mower blades are rotating.
3. Now, push the deck clutch switch down (clutch disengaged), and with the engine running, listen to confirm that the blades have stopped rotating.
4. If the mower blades continue to rotate with the deck clutch switch down, discontinue operation immediately and contact your Hustler® Dealer.

Follow these procedures to maximize clutch life:

1. Engage the clutch only when the throttle is set at approximately 1/2 - 3/4 throttle and there is no load on the blades. After clutch engagement, advance the engine throttle to full rpm. Engaging the deck clutch at high engine rpm or when under heavy load (in tall grass, for example) can cause belts and/or electric clutch to slip, resulting in premature wear or possible damage.
2. Disengage the clutch only when the throttle is set at less than 1/2 throttle. Never disengage the clutch with the engine

OPERATION

running at high rpm. Setting the throttle to less than 1/2 throttle when disengaging the clutch will help extend clutch life.

Warranty will not be allowed for deck clutches that fail due to improper engagement and disengagement practices.

Deck Cutting Height Adjustment

The deck cutting height is adjustable in 1/4" (6.3 mm) increments. The holes in the height adjusting bar are spaced at 1/4" (6.3 mm) intervals. Figure 3-14

To set the deck cutting height:

1. Push on the deck lift pedal to release pressure from the cutting height pin.
2. Place the pin in the desired cutting height hole.
3. Release the deck lift pedal.

To place the deck in the transport position:

1. Push on the deck lift pedal until the transport lever pin slips into the slot in the top of the height adjusting bar.
2. Release the deck lift pedal. Figure 3-14

To release the deck from the transport position:

1. Push on the deck lift pedal.
2. Pull on the transport lever handle until the transport lever pin lifts out of the slot.
3. Release the deck lift pedal to lower the deck to the desired cutting height.

Air Flow Baffles

Some decks are equipped with front adjustable air flow baffles. The baffles can be adjusted up or down, depending upon the mowing conditions, to provide the best quality of cut.

Setting	Condition
1. Bottom set of holes	Dry, sparse grass. Particularly useful when mowing at a height of cut of 3" (76.2 mm) or higher. This setting provides the maximum vacuum and minimal blowout.
2. Second set of holes	Manicured lawns. Provides the best vacuum for the best cut when removing weekly/bi-weekly growth.
3. Third set of holes	Tall and stemmy grasses. The higher inner wall allows grasses to snap back up before contacting the blades to produce a cleaner cut.
4. Top set of holes	Very tall and stemmy grasses. Allows the maximum height for grass to recoil before cutting. Well suited for utility cutting of overgrown grass.

NOTE: The air flow baffles are preset at the factory in the second setting.

Some decks come with three sets of mounting hardware for each air flow baffle. The middle set of hardware does not need to be removed when changing the baffle setting. This is a slot and the hardware only needs to be loosened enough to allow the baffle to slide. The other hardware on the ends of the baffles will need to be removed. After the baffles have been adjusted, re-install and tighten the outer hardware and tighten the middle hardware. Figure 3-15

Anti-scalp Wheels

Anti-scalp wheels are standard on these mowers. These wheels are designed to minimize scalping when mowing on rough uneven terrain. Figure 3-16

There are two height adjustment settings for the anti-scalp wheels/rollers. The upper hole positions the wheels/rollers 1" (25.4mm)

below the cutting blades and the lower hole positions them 2" (50.8mm) below the cutting blades. Figure 3-16

When the mowing height is set at 1" (25.4 mm) to 3" (76.2 mm) the anti-scalp wheels/rollers should be in the upper position.

When the mowing height is set at 3-1/4" (82.6 mm) to 5" (127 mm) the anti-scalp wheels/rollers should be in the lower position.

Maintenance Illustrations

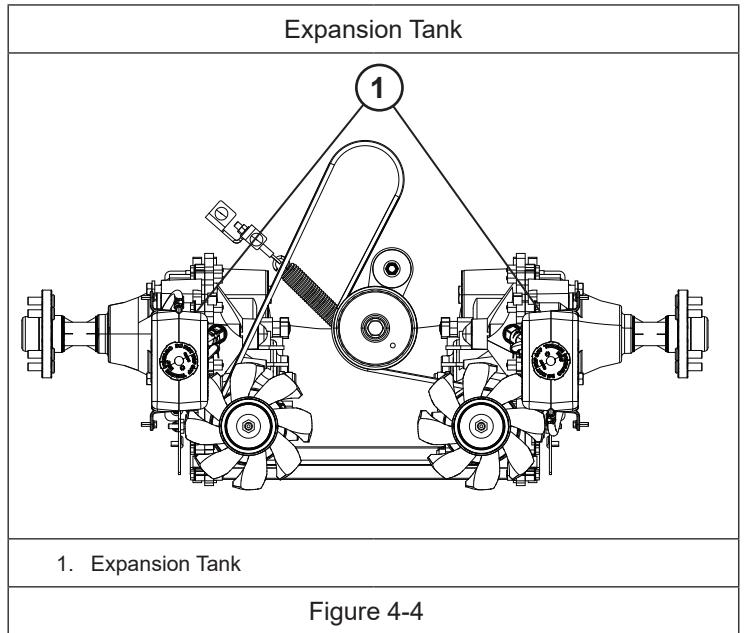
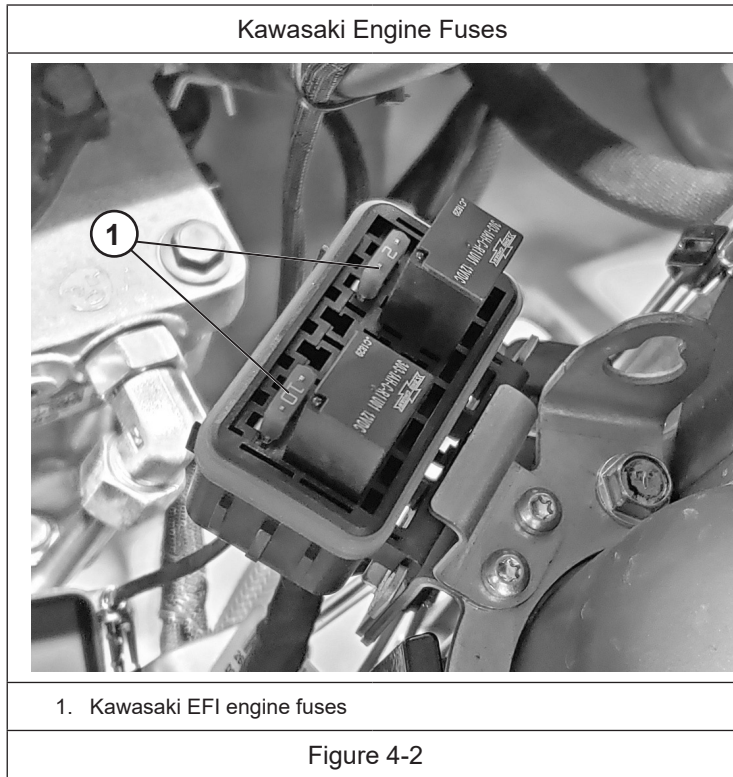
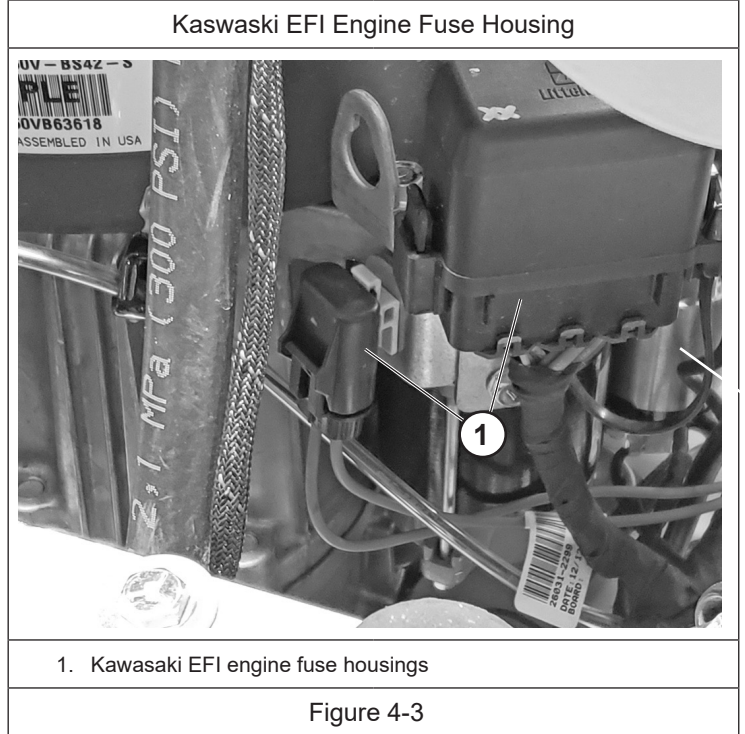
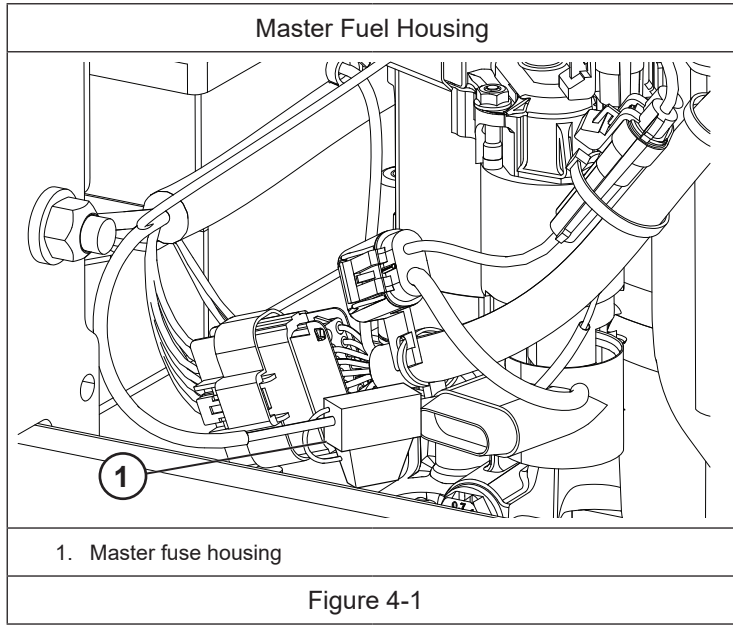

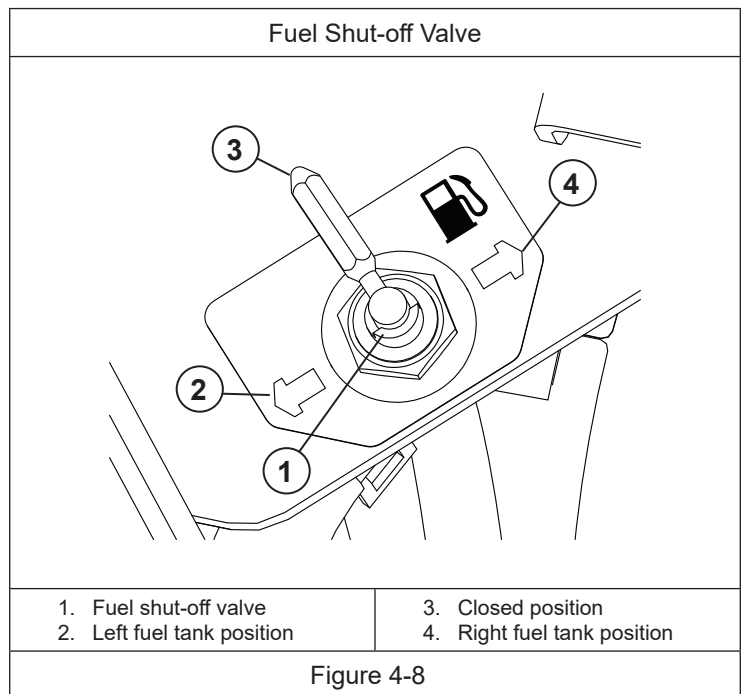
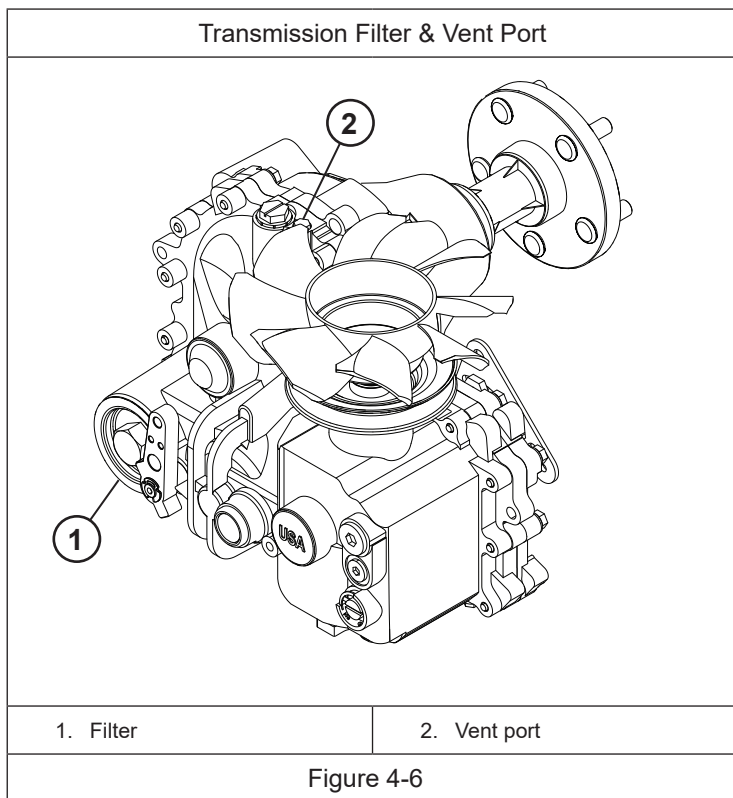
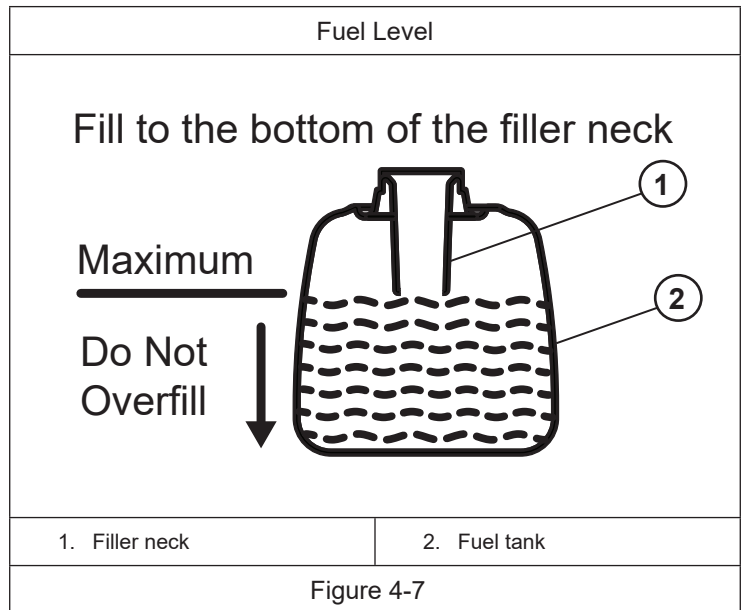
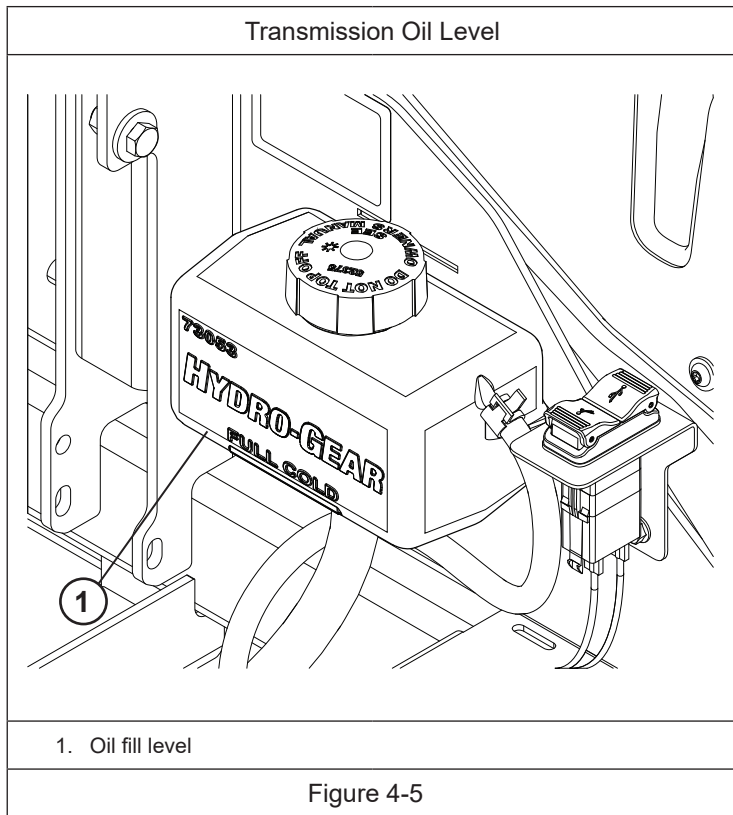

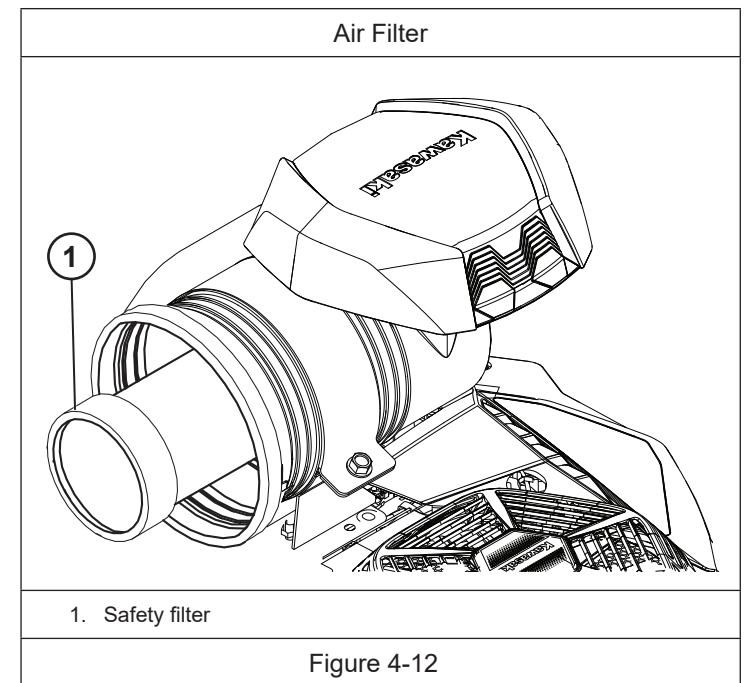
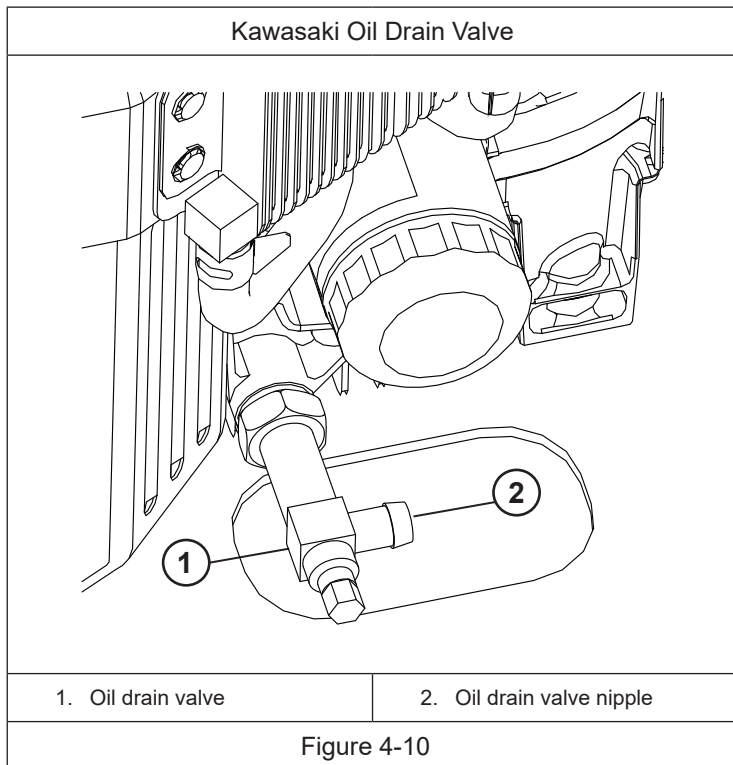
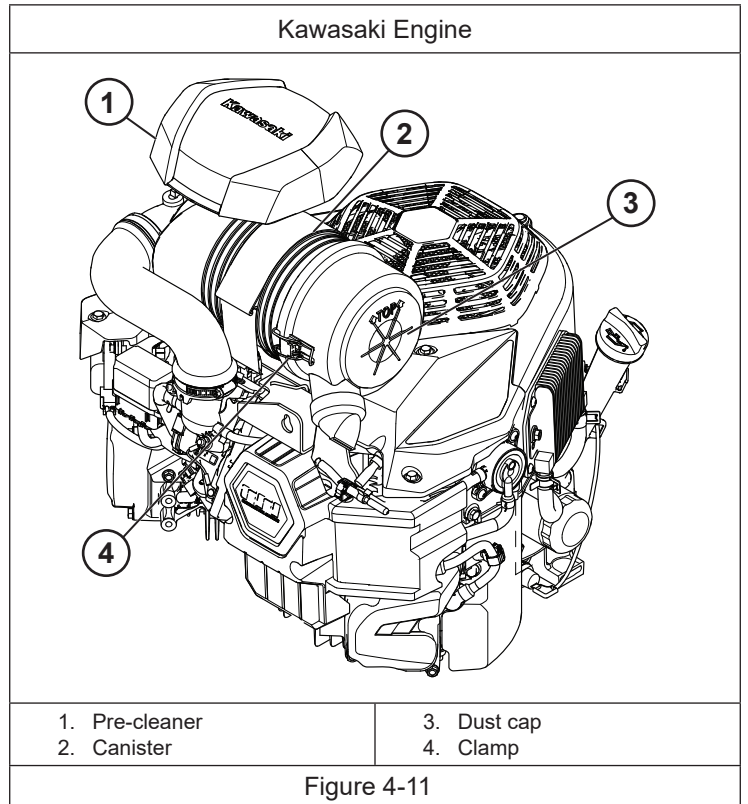
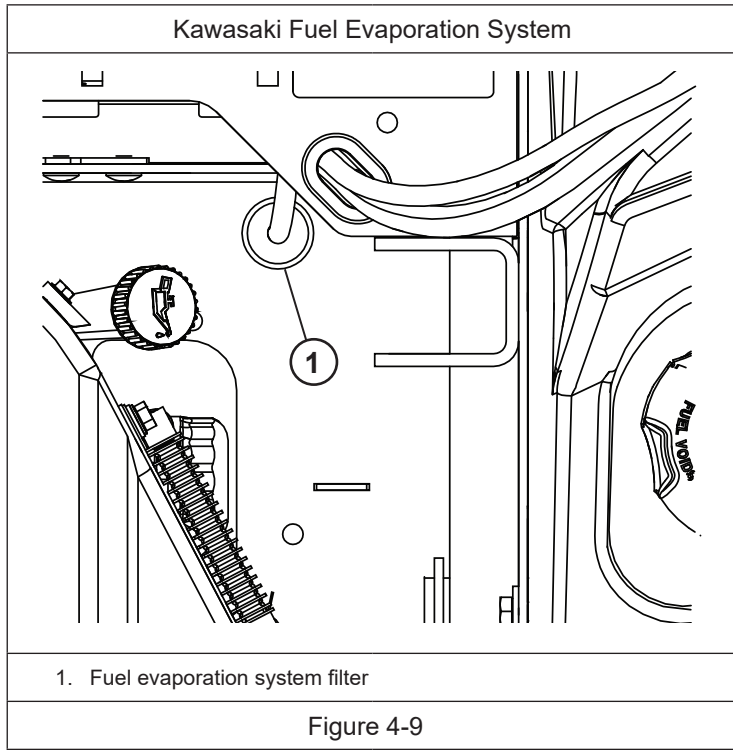

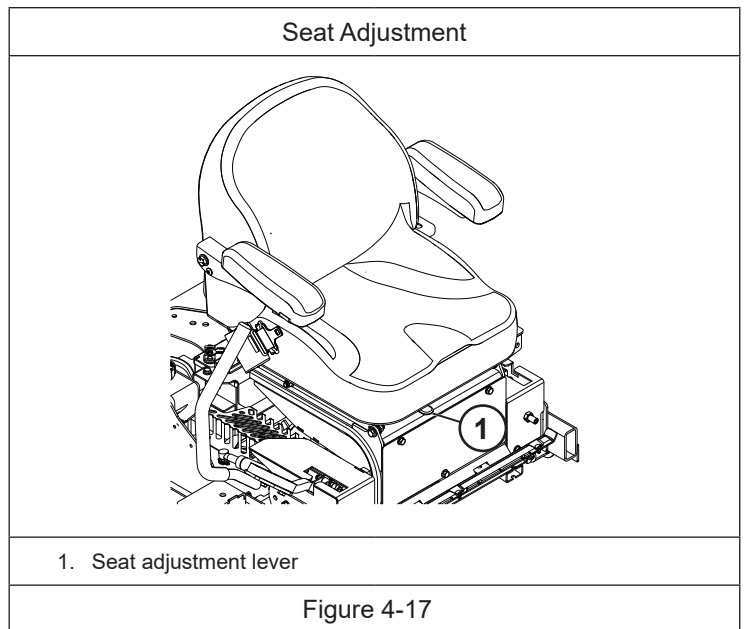
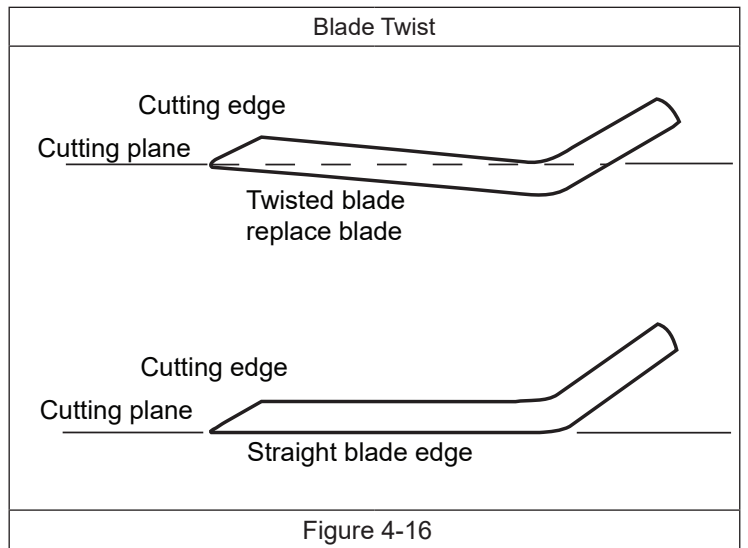
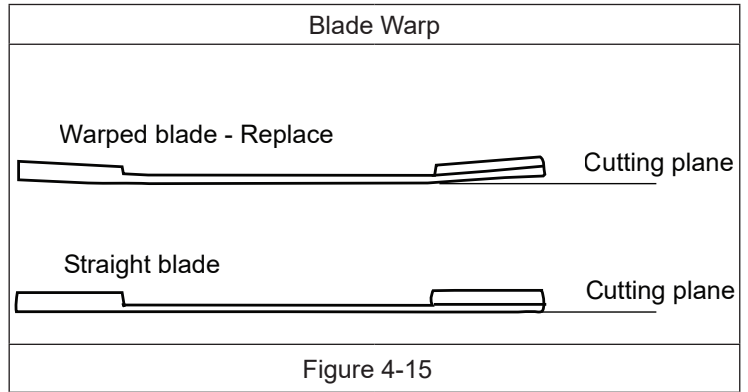
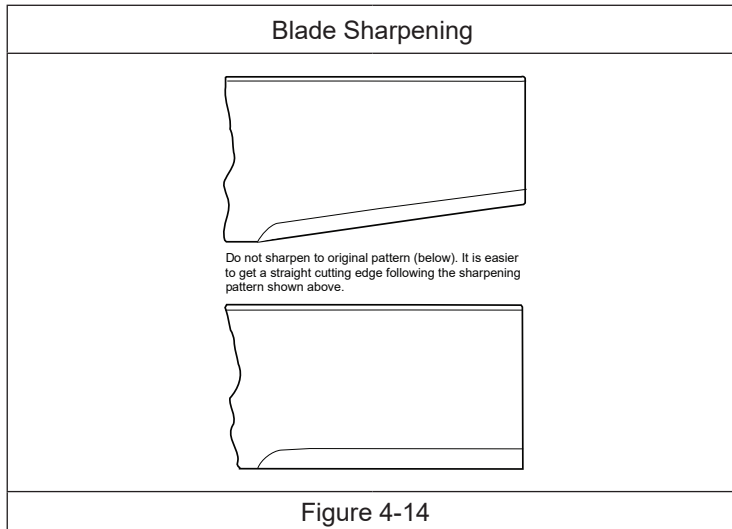
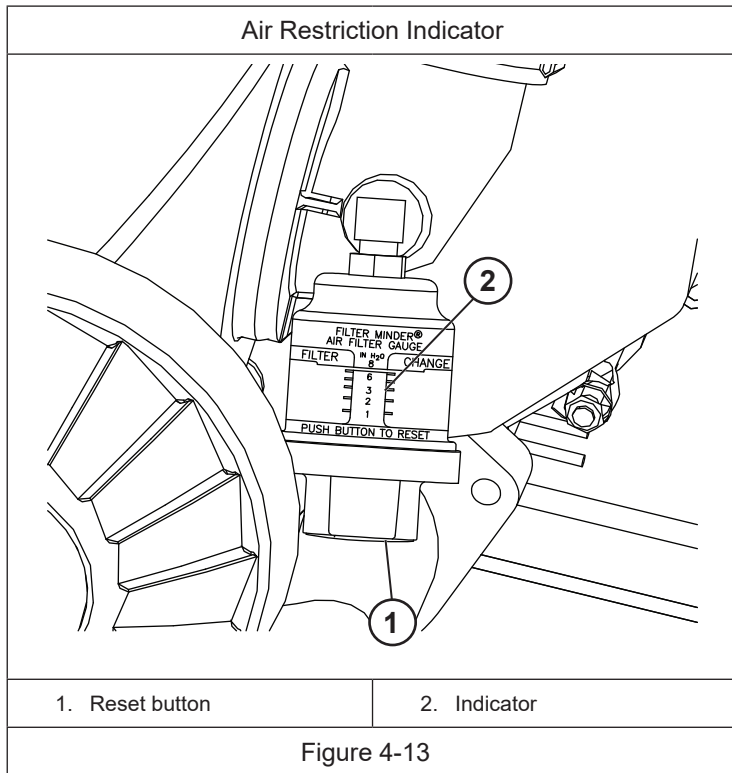

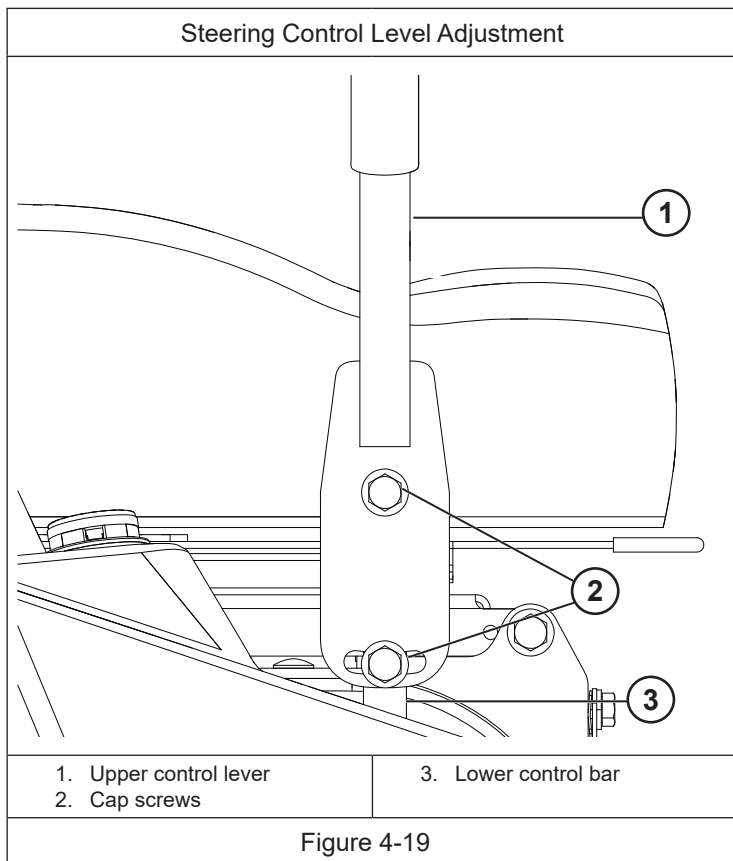
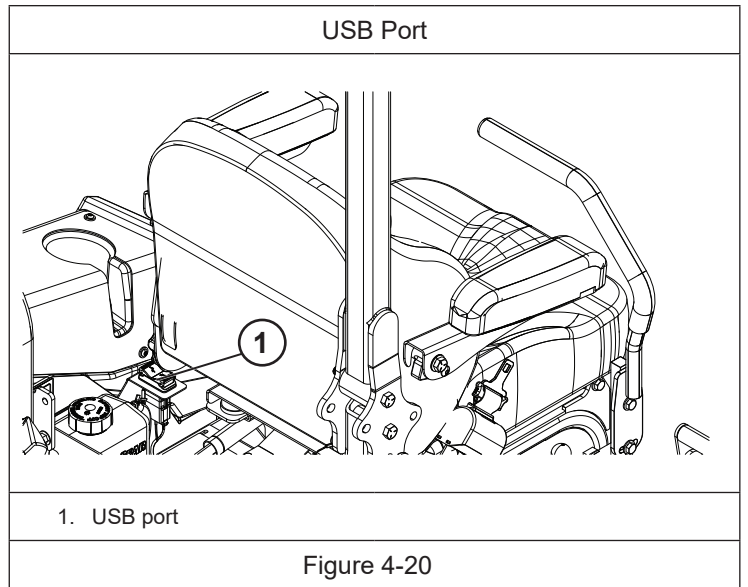
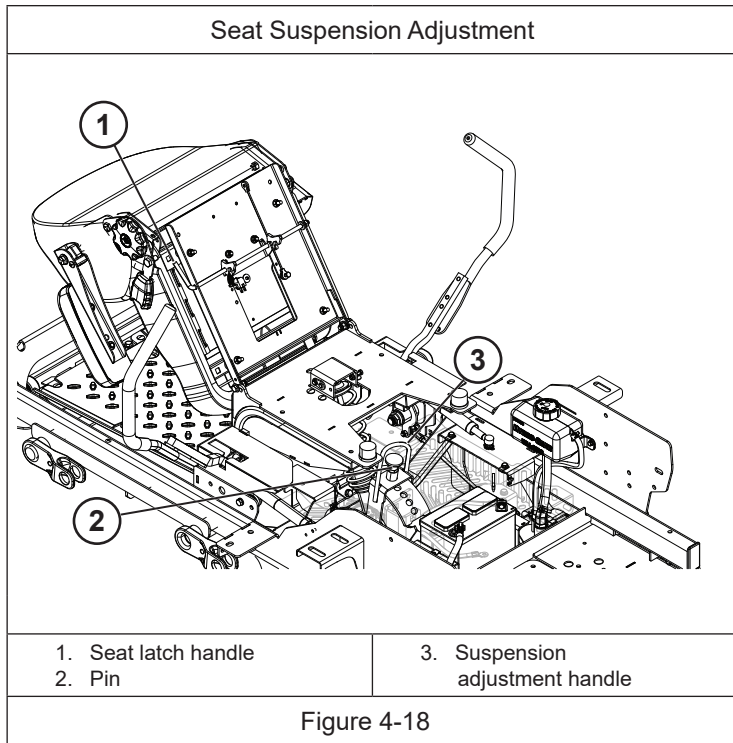

MAINTENANCE

Service Introduction

Regular maintenance is the best prevention for costly downtime or expensive, premature repair. The following pages contain suggested maintenance information and schedules which the operator should follow on a routine basis. For more detailed information order the correct Parts Manual and General Service Manual for your unit. Refer to the Product Literature section of this manual for more information.

Remain alert for unusual noises, which could signal a problem. Visually inspect the machine for any abnormal wear or damage. A good time to detect potential problems is while performing scheduled maintenance service. Correcting the problem as quickly as possible is the best insurance.

Clear away heavy build-up of grease, oil and dirt, especially in the engine and hydraulic component areas; minute dust particles are abrasive to close-tolerance engine and hydraulic assemblies.

Inspect mower daily for grass clippings and wire or string tangles. The underside of the mower deck will collect a build-up of grass clippings and dirt, especially when grass is wet or has high moisture content. This build-up will harden, restricting blade and air movement which will probably result in a poorer quality of cutting. Therefore it should be removed routinely. To do this it will be necessary to raise and block the deck using jack stands or blocks in the full up position. Scrape the build-up off from underneath.

IMPORTANT: Seat arm rests – Place the steering control levers in the park brake position and pivot the arm rests upward before lifting the seat platform to prevent arm rest damage.

Some repairs require the assistance of a trained service mechanic and should not be attempted by unskilled personnel. Consult your Hustler® service center when assistance is needed.

Torque Values

⚠ WARNING

Particular attention must be given to tightening the drive wheel lug nuts and blade spindle bolts. Failure to correctly torque these items may result in the loss of a wheel or blade, which can cause serious damage or personal injury

Torque values are given below:

	ft-lbs	N•m
Wheel (lug) nuts	.70	.95
Blade spindle bolt top	.70	.95
Blade spindle bolt bottom	.118	.160
Wheel motor nut	.230	.312

Lug nuts only - It is recommended that these be checked after the first 2 hours of operation, initially, every 50 hours and following removal for repair or replacement.

For all other torques refer to the mower's General Service Manual for standard torque chart. See Product Literature section for ordering information.

For engine torque values, refer to the engine owner's manual.

Tires

It is important for level mowing that the tires have the same amount of air pressure. The recommended pressures are:

	psi	KPa
Drive wheels	8–12 psi	55–83
Front wheels	8–12 psi	55–83

If you wish to use non-pneumatic tires on your Hustler® mower, the tire must be a Hustler® approved tire. Warranty claims will be denied on any mower equipped with unapproved non-pneumatic tires.

Flex Forks Break-In

Flex Forks® may raise the front of the mower approximately 1" (25.4 mm) when first installed. It is not necessary to re-level the deck at this time. Drive the mower for approximately 20 minutes, stop the mower and check to see if the deck is level. If adjustment is required, refer to the mower's General Service Manual for deck leveling procedures.

⚠ DANGER

Never attempt to make any adjustments to the mower deck while the engine is running or with the deck drive clutch engaged. Mower blades cannot be seen and are located very close to the deck housing. Fingers and toes can be cut off instantly

Lubrication

Use SAE multi-purpose grease.

Electrical System

IMPORTANT: Refer to the Safety section of this manual for detailed battery servicing safety information.

The electrical system is a 12 volt, negative ground. The recommended battery size is:

Garden tractor BCI group U1 with a 225 or better cranking AMP rating.

A maintenance-free battery is recommended. Otherwise, follow battery manufacturer's maintenance, safety, storing and charging specifications.

Master in-line fuse

These mowers have a master in-line fuse (40 amp) in the electrical system. This is the main fuse to protect the complete electrical system. It is located next to the starter solenoid which is mounted on the left front of the engine. Figure 4-1

Kawasaki EFI Engine Fuses

Mowers equipped with the Kawasaki EFI engines have three (3) engine fuses. Refer to the Kawasaki engine owner's manual for detailed information. Figure 4-2 & Figure 4-3

Hydraulic System

IMPORTANT: Refer to the General Service Manual (P/N 129595) for complete hydraulic oil and filter change procedures

IMPORTANT: Never use hydraulic or automatic transmission fluid in this system; use only motor oil as specified. Remember, dirt is the primary enemy of any hydraulic system.

⚠ WARNING

Hydraulic fluid escaping under pressure may have sufficient force to penetrate skin and cause serious injury. Foreign fluid injected into the skin must be surgically removed within a few hours by a doctor, familiar with this form of injury, or gangrene may result

Before applying pressure to hydraulic system, make sure all connections are tight and all hoses and lines are in good condition. To find a leak under pressure, use a piece of cardboard or wood — never use your hands. Relieve all pressure in the system before disconnecting or working on hydraulic lines. To relieve pressure, lower all attachments and shut off engine.

Check oil level in hydraulic system after every 50 hours of operation or weekly, whichever occurs first. Check more often if system appears to be leaking or otherwise malfunctioning.

The mower ships from the factory with SAE 20W50 oil in the system. Use SAE 20W50 oil, 15W50 synthetic oil, or 20W50 synthetic oil when changing the system oil and filter. Hustler® Full Synthetic 20W50 Hydrostatic Transmission Oil is recommended.

When Checking the hydraulic system's oil level:

1. Always check oil level with the mower on level ground.
2. Always check oil level when the oil is cold (mower has not run for at least 1.5 hours).
3. Always check oil level on side of expansion tank. Figure 4-4 & Figure 4-5

Initial system oil and filter change must be after the first 100 hours of mower operation. Thereafter, replace filter and oil in reservoir annually or every 400 hours, whichever comes first.

The system filter is located inside the transmission underneath the expansion tank. Use a Hustler® approved filter element only. When changing the filter use a 1-1/8" socket. The threads are right hand. Figure 4-6

Fuel and Evaporative Emissions Control System

IMPORTANT: Refer to the Safety section of this manual for fuel handling safety information.

IMPORTANT: Refer to the engine owner's manual for additional emissions control information.

Use only Hustler® approved replacement parts.

Your evaporative emission control system may include parts such as:

- fuel tanks
- fuel lines
- fuel line fittings
- fuel caps
- carbon canisters
- canister mounting brackets
- carburetor purge port connection
- filters
- vapor hoses

- clamps, control valves
- control solenoids
- electronic controls
- vacuum control diaphragms
- purge valves
- liquid/vapor separator
- other associated components

The fuel tanks are located in the mower's fenders.

⚠ WARNING

Use of replacement parts not equivalent to the original parts may result in system failure and pose a safety hazard.

Park the mower on level ground before filling the fuel tank. Clean the area around the fuel cap before removing the cap. Remove the fuel cap slowly.

When threading the fuel cap onto the filler neck, tighten the cap until it begins to click, then, continue to turn it until at least three clicks are heard.

IMPORTANT: Do not overfill the fuel tanks. The fuel tanks should be filled no higher than the bottom of the fill neck. Figure 4-7 The fuel system is designed to leave room for the fuel to expand with fuel temperature changes.

⚠ WARNING

Overfilling the fuel tank may cause the following:

- Engine damage
- Fire hazard!

Use regular unleaded gasoline with an octane rating of 87 or higher. Maximum of 10% ethanol (E10) in fuel. Fuels with greater than 10% ethanol (such as E15, E20 and E85) voids warranty. Fuels with greater than 10% ethanol are not approved for use and such illegal use could cause equipment failure and pose a fire hazard. Refer to the Engine Owner's Manual for additional fuel specification requirements.

Fuel Shut-off Valve

A fuel shut-off valve is located on each mower. The location and operation of the fuel valve will vary depending upon the unit. Close the fuel valve to prevent fuel flow to the engine. The valve's two other positions will allow fuel to be drawn from either one or the other fuel tank. Figure 4-8

Fuel Evaporation System Filter

These mowers have a fuel evaporation system filter. This filter must be checked and replaced every 500 hours or annually, whichever comes first. Figure 4-9

⚠ WARNING

Allow the engine to cool before changing the engine oil. If the engine has been running, use caution when changing the engine oil as it will be very hot. You should wear the appropriate protective gear to avoid being burned or exposed to engine oil

Check engine oil daily and after every 4 hours of operation. Machine must be sitting level when checking oil. Refer to engine manual and maintenance schedule for oil recommendation and capacities. Hustler® 15W-50 Engine Oil is recommended.

MAINTENANCE

Change the engine oil and filter per the engine manufacturer's recommendations. If mower is being operated in extremely dirty conditions, then it is recommended oil and filter be changed more frequently.

Kawasaki engine — Change the engine oil and filter after the first 100 hours of operation and per the engine manufacturer's recommendations after that. Refer to the engine owner's manual for detailed information. If mower is being operated in extremely dirty conditions, then it is recommended oil be changed more frequently.

IMPORTANT: After the new oil filter has been installed, clean up any oil which may have spilled onto the engine plate, engine exhaust system, and muffler guard.

Draining the engine oil (Kawasaki):

1. Locate the oil drain valve on the engine or at the bottom of the oil reservoir. Figure 4-10
2. Use a piece of 1/2" hose to drain oil into oil drain pan.
3. Attach one end of the hose onto the oil drain valve nipple. Make sure the hose is pushed all the way onto the valve. Figure 4-10
4. Position the loose end of the hose so that it can drain into a suitable oil drain container.

IMPORTANT: Make sure the oil does not come in contact with the belts or clutch.

5. Position a suitable oil drain container under the machine below the end of the hose.
6. Use a 10 mm wrench or socket and open the valve approximately 4 turns in the counterclockwise direction. Allow 10 minutes for engine oil to adequately drain.
7. After the oil is drained, close the valve by twisting clockwise.
8. Once the valve is closed, carefully remove the oil drain hose and clean up any spilled oil.

IMPORTANT: All oil drips or spills must be cleaned off of the engine plate, engine exhaust system, and muffler guard before operating the machine.

IMPORTANT: Clean the oil drain hose and store it appropriately before operating the machine.

Engine Air Filter

Perform engine air filter maintenance per the Maintenance Schedule shown elsewhere in this manual.

A specially designed dry filter is standard equipment on these mowers and supplies clean combustion air to the engine. Figure 4-11

These mowers are equipped with a safety filter. The filter element slides over the safety filter. Figure 4-12

The safety element does not require servicing unless it becomes contaminated with dirt or moisture.

Recommended Service Procedure

Release clamps and remove element. Clean the air cleaner canister with a damp cloth.

Before installing a new element, inspect it by placing a bright light inside and rotating the element slowly, looking for any holes or tears in the paper. Also check gaskets for cuts or tears. Do not attempt to use a damaged element which will allow abrasive particles to enter the engine.

Install the dust cap. Make sure it seals all the way around the air cleaner canister, then tighten the clamps.

Check all fittings and clamps periodically for tightness and inspect hoses for holes or cracks.

Periodically check the intake hose for signs of ingested dust. Locate and repair the source of ingested dirt.

Never operate the machine without an air filter installed.

Over servicing

Over servicing occurs when an air filter element is removed for cleaning or replacement before it is necessary. Each time the filter is removed a small amount of dirt and dust could fall in the intake system. This accumulated dirt can cause a dusted engine. It only takes a few grams of ingested dirt over the normal service life of an engine to cause a dusted engine.

Do not clean the element, replace with a new element only. Cleaning used air filter elements, through improper cleaning procedures, can get dust on the inside of the filter causing dirt ingestion and engine failure.

It is important to note that whenever an air filter element is cleaned by any method, the person or company performing the cleaning assumes responsibility for the integrity of the filter from then on. The warranty for air filters expires upon cleaning or servicing in any manner because the condition of the filter after servicing is completely out of the filter manufacturer's control. NOTE: On a dust ingested engine failure, there will be no warranty consideration if the air filter element has been cleaned or serviced in any manner.

A partially dirty air filter element works better than a new element. A dirty filter element is not bad for the engine unless it is excessively restricting the air flow and engine performance is affected. The media in the filter must be porous to allow air to pass through it. When dirty air passes through the filter, the dirt plugs some of the holes in the media and actually acts as part of the filter media. When the next round of dirt enters, the first dirt helps filter out even smaller particles making the filter more efficient at stopping dirt from entering the engine. This is referred to as barrier filtration. At some point the filter media becomes too clogged to allow air to pass. The mowing conditions will determine the frequency of air filter element changing.

Air Restriction Indicator

Some mowers have engines with an air restriction indicator installed in the air cleaner. Figure 4-13

Replace the element when the restriction indicator reaches the change filter red line. Check the indicator daily and replace element as needed or annually whichever occurs first.

Reset the indicator by pushing in on the yellow button after each element change. Figure 4-13

MAINTENANCE

General Engine Maintenance

Detailed instructions and recommendations for break-in and regular maintenance are specified in the Engine Owner's Manual. Please refer to the Engine Owner's Manual for engine servicing, lubricating oil levels with quality and viscosity recommendations, bolt torques, etc.

Belts

Inspect belts frequently for wear and serviceability. Replace a belt that shows signs of:

- severe cuts
- tears
- separation
- weather checking
- cracking
- burns caused by slipping.

Slight raveling of belt covering does not indicate failure, trim ravelings with a sharp knife.

⚠ WARNING

If the pump belt fails, loss of control will occur especially when operating on a slope. If you lose steering control while operating the machine, place the steering control levers in the park brake position immediately. Inspect the machine and involve your Hustler® Dealer to resolve the problem before continuing to operate

Inspect the belt pulley grooves and flanges for wear. A new belt, or one in good condition, should never run against the bottom of the groove. Replace the pulley when this is the case, otherwise the belt will lose power and slip excessively.

Never pry a belt to get it on a pulley as this will cut or damage the fibers of the belt covering.

Keep oil and grease away from belts, and never use belt dressings. Any of these will destroy the belt composition in a very short time.

Mower Blade Maintenance

IMPORTANT: Refer to the Safety section of this manual for blade handling safety information.

Refer to the Mower Blade Replacement section for blade removal and installation.

⚠ WARNING

Mower blades are sharp and can cut. Wrap the blade(s) or wear gloves and use extra caution when servicing them.

Check the mower blades daily, they are the key to power efficiency and well groomed turf. Keep the blades sharp. A dull blade will tear rather than cut the grass, leaving a brown ragged top on the grass within a few hours. A dull blade also requires more power from the engine.

Replace any blade which is bent, cracked or broken.

⚠ WARNING

Always check for blade damage:

- if mower strikes a rock, branch or other foreign object during mowing!
- or if an abnormal vibration occurs while operating

Make all necessary repairs before resuming operation.

Sharpen the blades following the pattern shown. Touch-up sharpening can be done with a file. Figure 4-14

After grinding the blades, check for balance. Blade balancing can be done by placing the blade on an inverted line punch or 5/8" bolt. A commercial balancing tool is also available through most hardware supply stores.

The blade should not lean or tilt. When spinning the blade slowly it should not wobble. Balance the blade before reinstalling.

Lay the blade on a flat surface and check for distortion. Replace any distorted blade. Figure 4-15 & Figure 4-16

Mower Blade Replacement

IMPORTANT: Refer to the Safety section of this manual for blade handling safety information.

⚠ WARNING

Mower blades are sharp and can cut. Wrap the blade(s) or wear gloves and use extra caution when servicing them.

A 15/16" wrench is required to remove the 5/8" cap screw holding the blade to the spindle shaft. NOTE: A blade holding tool (P/N 381442) is available from Hustler® Turf Equipment. It is designed to prevent the blades from rotating when they are being removed or installed on the spindle. Contact your Hustler® Dealer for more information.

Do not re-use spindle bolts which have stripped, worn or undercut threads. Torque bolts on spindles to 118 ft-lbs (160 N•m) when reinstalling blades.

⚠ WARNING

Failure to correctly torque the bolt may result in the loss of the blade which can cause serious injury.

Properly compressed cup washers maintain the correct compression load on the blades. Replace the cup washers if they are cracked or flattened.

IMPORTANT: The blade sail (curved part) must be pointing upward toward the inside of the deck to make sure of proper cutting.

When mounting blades, rotate them after installation to make sure blade tips do not touch each other or sides of the mower.

Seat Adjustment

IMPORTANT: Any maintenance operation that requires the removal of safety covers must be performed by a trained service technician.

This seat can be adjusted two different ways to obtain the most comfortable position:

1. Use the seat release lever to slide the seat forward and rearward. Figure 4-17

Seat Suspension Adjustment

1. Locate the seat latch on the left side of the mower seat. Figure 4-18
2. Grasp the seat latch and pull straight up and rotate seat forward until the seat is fully open.
3. Pull upward on the selection pin to release pressure from the suspension mechanism. Figure 4-18
4. Grasp handle and move to selection hole.
5. Place the pin over the desired suspension hole.

MAINTENANCE

6. Release the selection pin.
7. For a lighter ride select a lower number. The higher the number provides a more rigid ride.
8. Grasp the seat latch and rotate seat backwards until you hear a click indicating it is secured.
9. Check the seat belt. Make sure it will retract properly into the housing when it is released.

Steering Control Lever Adjustment

The steering control levers can be adjusted for operator comfort.

To pivot the upper control levers forward or rearward, loosen the cap screws that attach the upper control lever to the lower lever. Then, pivot the upper control lever. Tighten the cap screws. Figure 4-19

To lower and raise the control levers, remove the cap screws. Slide the upper control lever up or down and align the holes in it with the holes in the lower lever. Re-install the cap screws and tighten. Figure 4-19

The steering control levers should be adjusted so that they align with each other when in the neutral position.

USB Port

Two USB power sources are located on the left side between the seat and instrument panel. The ports are rated 2.1A total, and can be used to charge your phone or other USB devices. Figure 4-20

WARNING

Do not have any devices plugged into your USB charging port when starting the tractor. Doing so may cause damage to your device.

STORAGE

When storing the unit at the end of the mowing season, the mower, engine, and battery should have the following items serviced before storage.

If the mower has been stored for an extended period of time, follow the new season preparation steps before beginning operation.

General Mower Preparation for Storage

1. Remove all grass, dirt, and trash from mower and cutting units.
IMPORTANT: Wash the machine with a mild detergent and water. Do not pressure wash the machine. Avoid excessive use of water, especially near the control panel and engine.
2. Clean mower and deck and touch up all scrapes with touch-up paint.
3. Replace air filter element.
4. Check thoroughly for any worn or damaged parts that need replacing and order them from your dealer.
5. Thoroughly lubricate machine, according to the Maintenance section.
6. Block mower up so weight is off tires. Check tire pressure and inflate to proper operating pressure.

NOTE: Do not deflate tires.

7. Perform separate engine and battery preparation as listed below.
8. Store mower in a clean, dry place.

Preparation of Engine for Storage

If the mower is to be unused for an extended period of time (30 days or more), the engine will need to be prepared for storage. Use the following procedures before storing the mower.

IMPORTANT: Refer to the Fuel Handling Precautions section of this manual for important safety information before proceeding.

1. Add a Hustler® approved fuel stabilizer to the fuel system. Refer to the instructions shown on the fuel stabilizer bottle for proper usage. Hustler® Fuel Stabilizer with Cleaner is recommended. For detailed information consult with your Dealer.
2. Fill the fuel tank(s) with fresh fuel.

NOTE: Use non-ethanol fuel if possible.

⚠ WARNING

Failure to correctly torque the bolt may result in the loss of the blade which can cause serious injury.

WARNING: To prevent carbon monoxide poisoning, operate the engine in a well ventilated area only.

3. Run the engine for a minimum of 10 minutes.

⚠ WARNING

Failure to correctly torque the bolt may result in the loss of the blade which can cause serious injury

WARNING: Allow the engine to cool before changing the engine oil. Use caution when changing the engine oil as it will be very hot. You should wear the appropriate protective gear to avoid being burned or exposed to engine oil.

4. Drain the oil from the crankcase while the engine is still warm.
5. Replace the engine oil filter.
6. Refill with fresh oil of the proper viscosity. Hustler® Synthetic 15W-50 engine oil is recommended.

7. Close the fuel shut-off valve (if equipped).
8. Check the oil filler cap and fuel tank cap(s) to make sure they are securely in place.
9. Refer to the engine manual for more information.

Preparation of Battery for Storage

When the machine is to be unused for long periods, it is best to disconnect the battery and remove it from the unit. At this time perform the following battery maintenance:

1. Remove the battery from machine.
NOTE: Always disconnect the negative (black) battery cable(s) before disconnecting the positive (red) cable(s).
2. Clean the battery, terminals, and cable connectors.
3. Charge the battery, if necessary.
4. Store the battery in a cool, dry place (do not expose to freezing temperatures).
5. Always keep the battery fully charged. Especially important to prevent battery damage when the temperature is below 32°F (0°C).

New Season Preparation

Before starting the mower following post season storage, the following service is required:

1. Clean mower, removing trash and dirt accumulation.
2. Check engine oil and hydraulic oil levels.
3. Install fully charged battery and attach the battery cables.
IMPORTANT: Always connect the positive (red) battery cable(s) before connecting the negative (black) cable(s).
4. Fill fuel tank(s) with fresh fuel. Run machine at half speed for 5 minutes, checking operation of steering control levers. Stop engine and check for oil leaks, loose fittings and so forth.
5. Tighten any bolts that have loosened and make sure all hair pins, cotter pins and clevis pins are in place.

⚠ WARNING

At start of new season always check that fresh oil has been added to machine. If oil is drained at season's end and not replaced, engine damage will result.

7. Install all safety shields and review safety precautions listed in this manual.
8. Check and inflate tires to 8–12 psi (55–83 KPa).
9. Refer to engine manual for more information.

MAINTENANCE

Maintenance Schedule

SERVICE AT INTERVALS INDICATED	FREQUENCY	NOTES:
Verify safety start interlock system	Prior to each use	
Visually inspect unit for loose hardware &/or damaged parts	Prior to each use	
Visually inspect tires	Prior to each use	
Clean air intake screen	Prior to each use	Service more often under dusty or dirty conditions and during hot weather. Refer to Engine Owner's Manual
Check fuel level	Prior to each use	
Blades - sharpen & fastened securely	Prior to each use	
Discharge chute - securely in place & in lowest position	Prior to each use	
Check tire pressure with a gauge	Prior to each use	
Clean engine and pump/transaxle/transmission compartment (as equipped)	After each use	Any maintenance operation that requires the removal of safety covers must be performed by a trained service technician. Refer to the General Service Manual.
Check air cleaner service indicator	After each use	Service more often under dusty or dirty conditions and during hot weather. Refer to Engine Owner's Manual
Caster fork tapered bearings	Regular maintenance not required	Any maintenance operation that requires the removal of safety covers must be performed by a trained service technician. Refer to the General Service Manual.
Tighten lug nuts/axle bolts on wheels	Weekly or 40 hours	Torque initially and after first 2 hours of operation.
Check battery connections	Weekly or 50 hours	Any maintenance operation that requires the removal of safety covers must be performed by a trained service technician. Refer to the General Service Manual.
Check hydraulic oil level	Weekly or 50 hours	Any maintenance operation that requires the removal of safety covers must be performed by a trained service technician. Refer to the General Service Manual.
Check pump and deck belt tension and condition	Monthly or 100 hours	Pump drive belt only - Inspect every month and replace if worn or cracking is noticed. Otherwise, replace every 2 years. Pump drive belt only - Inspect every 6 months or 100 hours and replace if worn or cracking is noticed. Otherwise, replace every 200 hours or 2 years whichever comes first. Refer to Cold weather pump clutch section for tensioning information. Service more often under dusty or dirty conditions and during hot weather.
Check fuel tank grommets	Monthly or 100 hours	
Grease deck height pivots	Monthly or 100 hours	Service more often under dusty or dirty conditions and during hot weather. Refer to General Service Manual.
Grease front wheel bearings	Monthly or 100 hours	Refer to General Service Manual.
Check fuel valve	Monthly or 100 hours	Check fuel system for any cracks or leaks including, but not limited to, fuel line hoses, fuel valve, vent line hoses, vent valve, vapor valve, carbon canister, and grommets. Replace as needed.
Grease deck pusher arms	Monthly or 100 hours	Service more often under dusty or dirty conditions and during hot weather. Refer to Engine Owner's Manual
Grease pump belt idler pivot	Monthly or 100 hours	Service more often under dusty or dirty conditions and during hot weather. Refer to Engine Owner's Manual
Check ROPS mounting hardware	Annually or 300 hours	Any maintenance operation that required the removal of safety covers must be performed by a trained service technician. Refer to the General Service Manual."
Change hydraulic filter & oil	Annually or 400 hours	Refer to General Service Manual
Grease deck spindle housings	Annually or 500 hours	
Replace fuel evaporation system filter (if equipped)	As needed or annually, depending on usage.	
Check engine oil level	Refer to Engine Owner's Manual	
Replace engine air cleaner element	Refer to Engine Owner's Manual	
Change engine oil & filter	Refer to Engine Owner's Manual	
Clean cylinder & head fins (as equipped)	Refer to Engine Owner's Manual	
Clean engine exterior	Refer to Engine Owner's Manual	
Clean & gap spark plugs	Refer to Engine Owner's Manual	
Check fuel system	Refer to Engine Owner's Manual	
Change fuel filter	Refer to Engine Owner's Manual	
Replace spark plugs	Refer to Engine Owner's Manual	

MAINTENANCE

Maintenance Locator

MAINTENANCE LOCATOR

- | | |
|--|---|
| <ol style="list-style-type: none">1. Engine Oil Fill & Dipstick2. Fuel Filter3. Engine Oil Drain Valve4. Engine Oil Filter5. Engine Air Cleaner6. Fuel Tanks7. Drive Tires8. Hydraulic Oil Reservoir9. Battery10. Hydraulic Oil Filter11. Park Brake Switch12. Deck Height Pivot Grease fitting (4) | <ol style="list-style-type: none">13. Front Wheel Tires14. Front Wheel Bearing Grease fitting (2)15. Caster Fork Tapered Grease fitting16. Fuel Evaporation System Filter17. Pump Idler Grease fitting18. Pump Belt19. Deck Pusher Arm Grease fitting (2)20. Deck Belt21. Spindle Housing Grease fitting (3)22. Blades |
|--|---|

KAWASAKI ENGINE

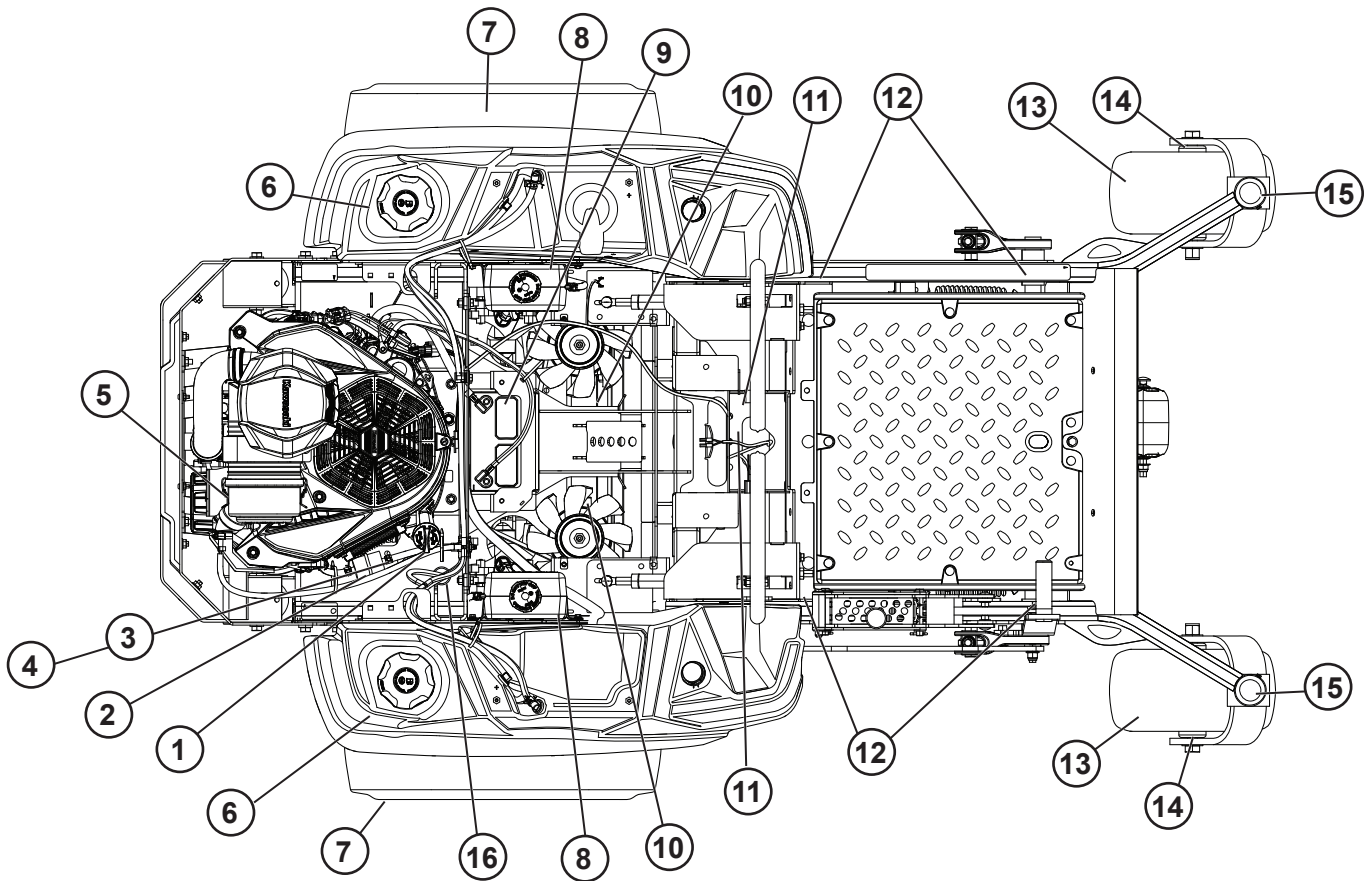

Figure 7-1

PUMP BELT ROUTING

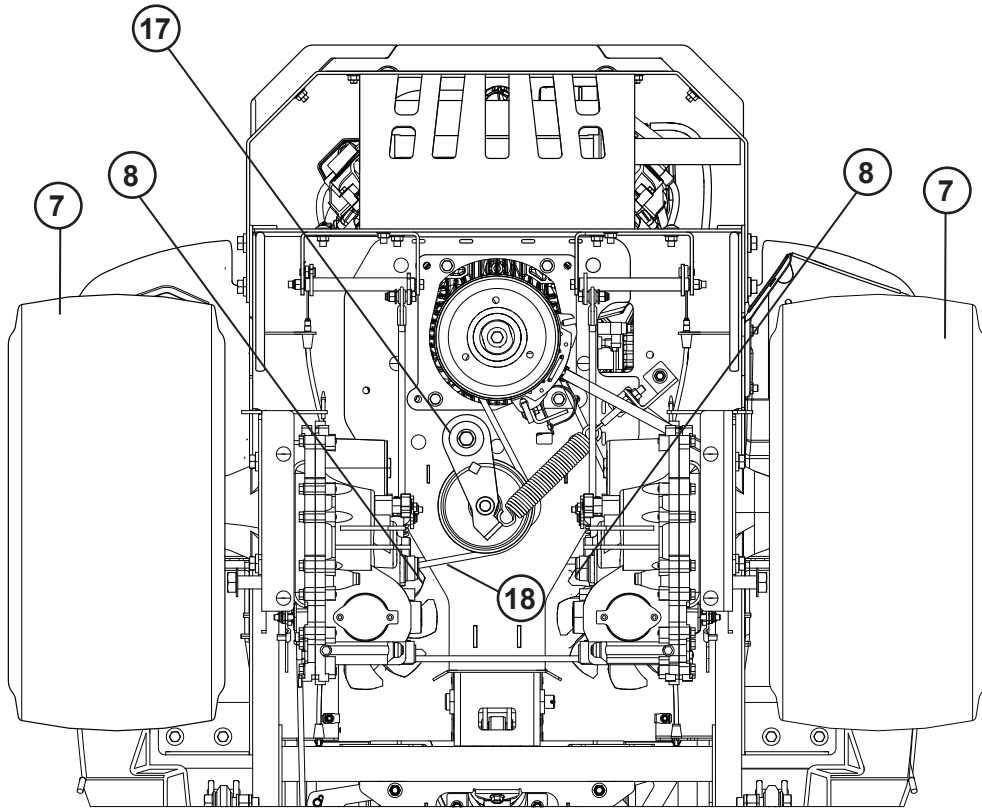

Figure 7-2

60" VX4 DECK

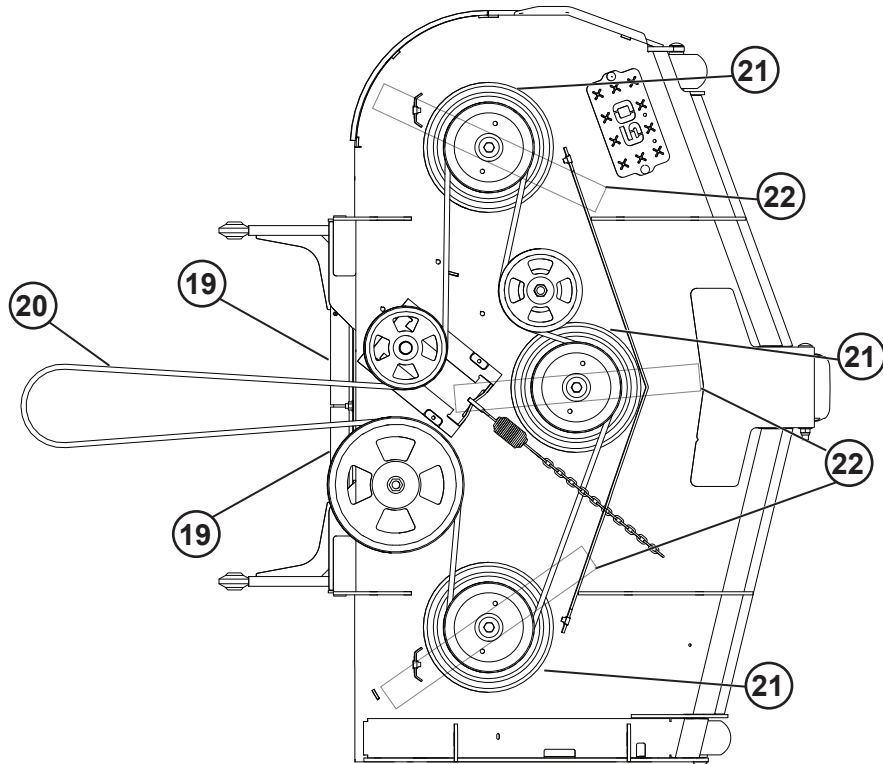

Figure 7-3

TROUBLESHOOTING

Troubleshooting:

The majority of operating problems that occur with a system can be traced to improper adjustments or delayed service. A consistently applied preventative maintenance program, as outlined in the Maintenance section of this manual, will prevent many problems. The following chart is designed to help you locate a problem by suggesting probable causes and the recommended solutions.

Symptoms	Probable Causes	Suggested Remedies
Starting motor does not crank	Steering control levers not in park brake position or switch not adjusted	Place steering control levers in park brake position or adjust switch.
	Deck clutch switch engaged	Disengage clutch switch
	Weak or dead battery	Recharge or replace
	Electrical connections are corroded or loose	Check the electrical connections
	Fuse is blown	Check fuses – replace blown fuse
	For additional causes	See engine manual
The engine will not start, starts hard or fails to keep running	No fuel or line plugged	Fill tank or replace line (See Fuel System section for more details)
	Fuel valve is turned off	Open the fuel valve
	There is incorrect fuel in the fuel system	Drain the tank and replace the fuel with the proper type
	There is dirt in the fuel filter	Replace the fuel filter
	Dirt, water or stale fuel in the fuel system	Contact your dealer
	The choke (if equipped) is not on	Move the choke lever to ON
	Numerous	See engine manual
Engine: Runs with continuous misfiring or engine runs unevenly or erratically	Numerous	See engine manual
Loss of power or system will not operate in either direction	Restrictions in air cleaner	Service air cleaner
	Internal interference or leakage in transaxle	See your dealer
	Poor compression	See your dealer
	Steering linkage needs adjustment	Adjust linkage
	Tow valve open	Close tow valve
	The traction drive belt is worn, loose or broken	Install a new traction drive belt
	Air in system	Check filter and fittings
	For additional causes	See engine manual
Low engine oil pressure	Low oil level	Add oil
	Oil diluted or too light	Change oil and check for source of contamination
	Failed oil pump	Contact your dealer
High oil consumption	Numerous	Contact your dealer
Mower jerky when starting or operates in one direction only	Steering control linkage needs adjustment	Adjust linkage
	Transaxle component faulty	Contact your dealer
	Tow valves not closed completely	Close tow valves
	Loose steering linkage	Tighten linkage

Symptoms <i>continued</i>	Probable Causes	Suggested Remedies
Mower creeps when steering control levers are in neutral	Steering linkage needs adjustment	Adjust linkage
Mower circles or veers in one direction	Steering linkage needs adjustment	Adjust linkage
	Loose steering linkage	Tighten linkage
	Tires improperly inflated	Adjust air pressure to 8–12 psi (55–83 KPa)
	Transaxle component faulty	Contact your dealer
Mower creeps when parking brake engaged	Steering linkage out of adjustment	Adjust steering linkage
	Brakes need adjustment	Adjust parking brakes
There is abnormal vibration	The engine mounting bolts are loose	Tighten the engine mounting bolts
	The engine pulley, idler pulley or blade pulley is loose	Tighten the appropriate pulley
	The engine pulley is damaged	Contact your dealer
	The cutting blade(s) is/are bent or unbalanced	Install new cutting blade(s)
	A blade mounting bolt is loose	Tighten the blade mounting bolt
	Spindle bearing is worn or loose	Replace or tighten spindle bearing
Blades do not rotate	A blade spindle is bent	Contact your dealer
	The deck drive belt is worn, loose or broken	Install a new deck drive belt
	The deck drive belt is off the pulley	Install the deck drive belt and check for a reason
	Electric clutch is not engaging	Check and/or replace 10 amp fuse. Contact your dealer
	Uneven cutting height	The blade(s) are not sharp
A cutting blade(s) is/are bent	The deck is not level	Level the deck per the Deck leveling and height adjustment section of the General Service Manual
	An anti-scalp wheel is not set correctly	Adjust the height of the anti-scalp wheel
	The underside of the deck is dirty	Clean the underside of the deck
	Tires improperly inflated	Adjust air pressure to 8–12 psi (55–83 KPa)
	A blade spindle is bent	Contact your dealer
	Flex Forks® are installed	After initial break-in period, level the deck per the Deck Leveling section of the General Service Manual.

INDEX

GENERAL INFORMATION

To the New Owner	1
Using this Manual	1
Warranty Registration	1
Model and Serial Number	1
Parts and Service	1

SAFE OPERATION PRACTICES

Training	2
General Operation	2
Slope Operation	3
Slope gauge (back cover)	3
Children	3
Towing	4
Transporting Machines	4
Operator Protective System (OPS)	4
Hydraulic Devices and Systems	5
Service	5
General Service	5
Do Not Modify Engine	6
Safety Symbols	6

OPERATION

Operation Illustrations	8
Safe Operating Practices	13
Control Panel	13
Controls	13
Safety Start Interlock System	13
Engine Starting	13
Stopping the Engine	14
Moving the Mower with Stalled Engine	14
ROPS (Roll Over Protective Structure)	14
ROPS Inspection	15
Mower Operation	15
Driving the Mower	15
Operating Suggestions	15
Flex Forks	16
Deck Clutch Operation	16
Deck Cutting Height Adjustment	17
Air Flow Baffles	17
Anti-scalp Wheels	17

MAINTENANCE

Maintenance Illustrations	18
Service Introduction	23
Torque Values	23
Tires	23
Flex Forks Break-In	23
Lubrication	23
Electrical System	23
Master in-line fuse	23
Hydraulic System	23
Fuel and Evaporative Emissions Control System	24
Fuel Shut-off Valve	24
Fuel Evaporation System Filter	24
Engine Air Filter	25
Air Restriction Indicator	25
General Engine Maintenance	26
Belts	26
Mower Blade Maintenance	26
Mower Blade Replacement	26
Seat Adjustment	26
Seat Suspension Adjustment	26
Steering Control Lever Adjustment	27
USB Port	27

STORAGE

General Mower Preparation for Storage	28
Preparation of Engine for Storage	28
Preparation of Battery for Storage	28
New Season Preparation	28

MAINTENANCE

Maintenance Schedule	29
Maintenance Locator	30

TROUBLESHOOTING

Troubleshooting:	32
----------------------------	----

SLOPE GUIDE

Slope Guide	35
-----------------------	----

SLOPE GUIDE

Slope Guide

Use this diagram when determining the degree of slope to be mowed.

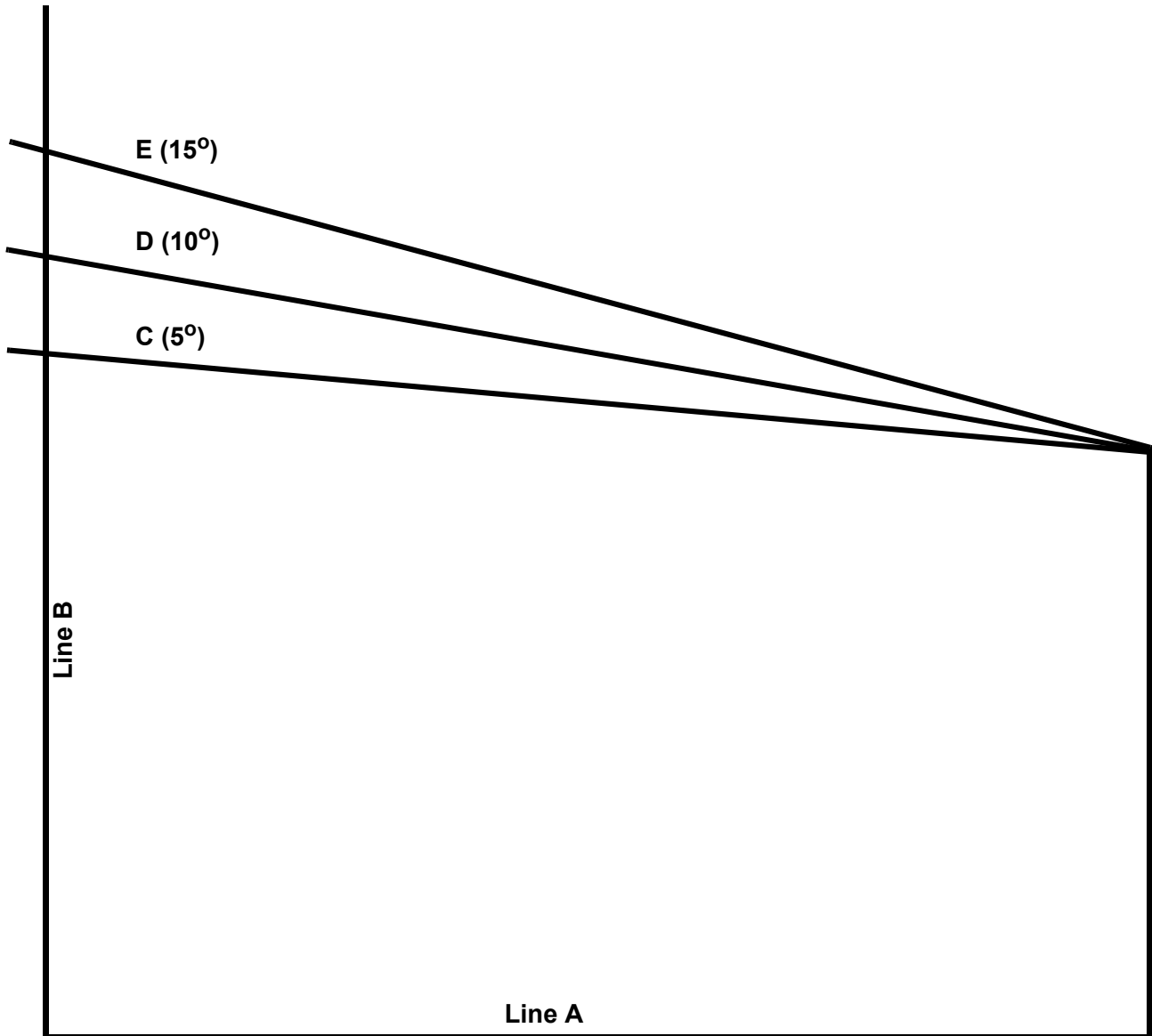

1. Hold this sheet of paper in front of you. Make sure that Line A is horizontal.
2. Align Line B with a vertical surface such as pole, tree or building.
3. Fold the paper along the slope guide lines (C, D or E).
4. Align the closest slope guide line with the ground slope. This will give you a close estimation of the ground slope to be mowed.