

# Hustler® Parts Manual



**HUSTLER®**  
TURF EQUIPMENT

200 South Ridge Road

Hesston, Kansas

67062



#### NOTICE OF REQUIREMENT OF SPARK ARRESTER MUFFLER

This equipment may create sparks that can start fires around dry vegetation. California Public Resources Code Section 4442.6 provides that it is unlawful to use or operate an internal combustion engine on any forest-covered, brush-covered, or grass-covered land unless the engine is equipped with a spark arrester maintained in effective working order. A spark arrester is a device constructed of nonflammable materials specifically for the purpose of removing and retaining carbon and other flammable particles over 0.0232 of an inch in size from the exhaust flow of an internal combustion engine that uses hydrocarbon fuels or which is qualified and rated by the United States Forest Service. Other states or federal areas may have similar laws. The Operator Should Contact Local Fire Agencies For Laws or Regulations Relating to Fire Prevention Requirements. **THIS EQUIPMENT DOES NOT HAVE A SPARK ARRESTER AND YOU SHOULD CONTACT YOUR AUTHORIZED DEALER FOR THE PURCHASE OF A SPARK ARRESTER.**

Inspect spark arrester daily; replace every 500 hours or as needed.

The Engine Owner's Manual provides information regarding the U.S. Environmental Protection Agency (EPA) and the California Emission Control Regulation of emission systems, maintenance and warranty.

Keep Engine Owner's Manual with your unit. Should the Engine Owner's Manual become damaged or illegible, replace immediately. Replacements may be ordered per the information found in the Product Information section of the owner's manual.

Federal law and California State law prohibit the following acts or the causing thereof:

1. The removal or rendering inoperative by any person other than for purposes of maintenance, repair, replacement, of any device or element of design incorporated into any equipment for the purposes of emissions control prior to or after its sales or delivery to the ultimate purchaser or while it is in use, or
2. The use of the equipment after such device or element of design has been removed or rendered inoperative by any person.

Catcher Frame	1
Catcher Lid - 552396	2
Catcher Chute & Blades	3
Catcher Bag Assembly - 552460	4



Item	Part No.	Qty	Name
1	023036	2	HP 0.148X2.690
2	604887	2	CE .375 X 3.00 W/BALE
3	117394	1	CATCHER FRAME
4	029629	6	CS .375-16X0.75 HXF G5ZN
5	016899	6	NT .375-16 FLKG5
6	604301	2	TIE ROD
7	086660	2	NT .375-16NLG8
8	117303	1	SUPPORT GUSSET LH
9	117304	1	SUPPORT GUSSET, RH
10	054502	4	NT .375-16HXG5
11	767954	4	FW 0.379X.82X.06 HD ZN
12	025395	4	CB .375-16X 1.00 G5 ZN
13	120864	1	LATCH SUPPORT W/A
14	604475	1	BUNGEE
15	068551	1	NT .250-20 HXZY NL
16	768515	2	FW 0.281SAE
17	704916	1	CS .250-20X1.250HXG5
18	604375	1	WEIGHT 18 LBS
19	122390	1	WEIGHT TRAY W/A
20	122393	1	WEIGHT TRAY
21	792002	1	KNOB,5/16-18 X 3/4"MALE

Comments for Page: Catcher Frame

1. The catcher frame (552148) includes the decal.

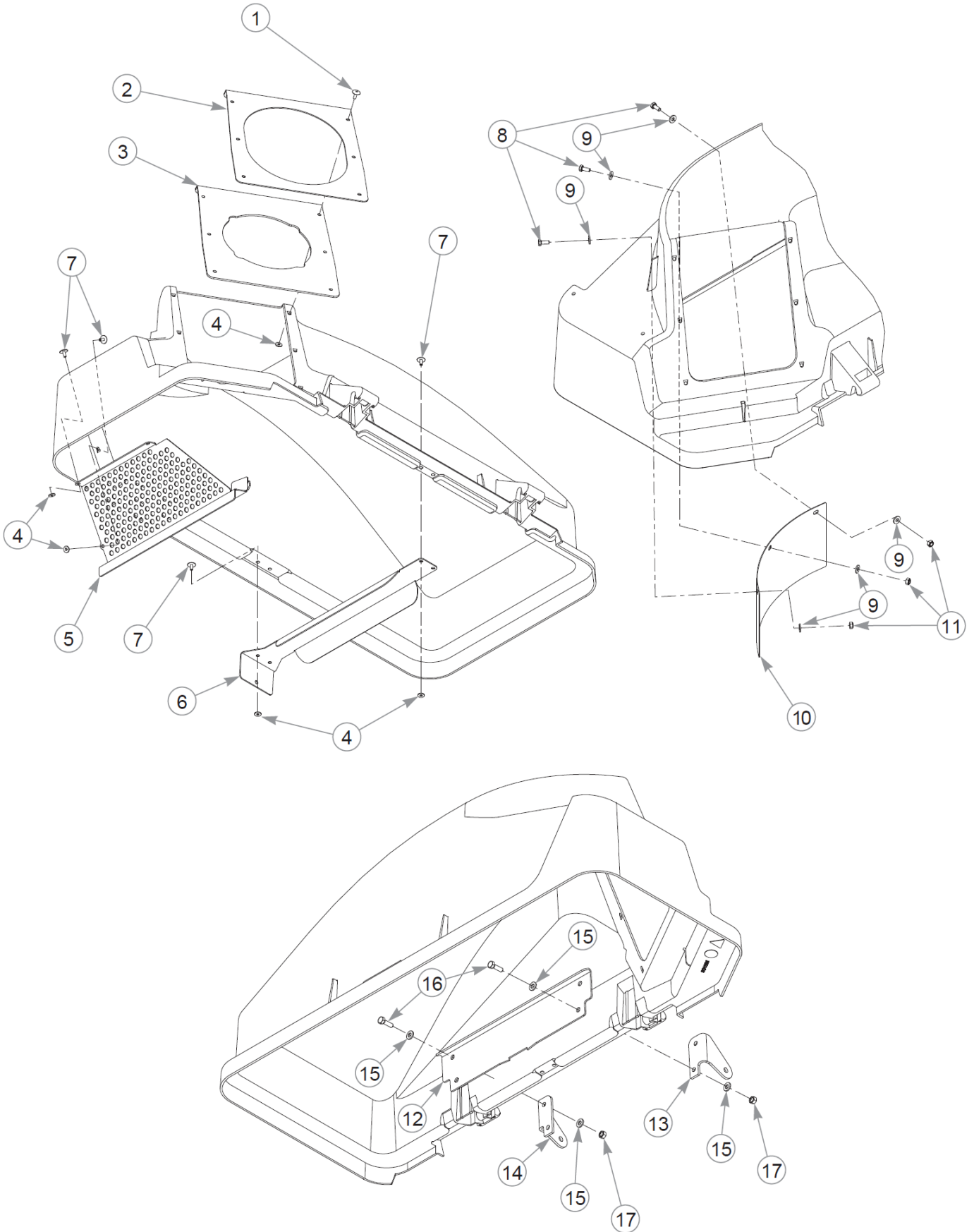

Item	Part No.	Qty	Name
Not Shown	552396	1	SERVICE LID
<p>Comments for Part Num. 552396</p> <p>552396 CATCHER LID comes assembled with the bag divider, catcher vent, stiffener plate, debris guide, hinge brackets, catcher inlet seal and hardware.</p>			
1	603398	6	RIVET, BLIND
2	117501	1	CATCHER INLET
3	604394	1	INLET SEAL
4	603400	13	FW .188"X .50"X .060
5	117678	1	CATCHER VENT
6	117584	1	BAG DIVIDER
7	604805	7	BLIND RIVET ALUM/STEEL
8	064329	3	CS .250-20X0.625HXG5
9	768515	6	FW 0.281SAE
10	118562	1	DEBRIS GUIDE
11	068551	3	NT .250-20 HXZY NL
12	120884	1	STIFFENER PLATE
13	120882	1	HINGE BRACKET RS
14	120883	1	HINGE BRACKET LS
15	768523	8	FW 0.343SAE
16	036236	4	CS .312-18X1.000HXG5
17	034272	4	NT .312-18HXG5

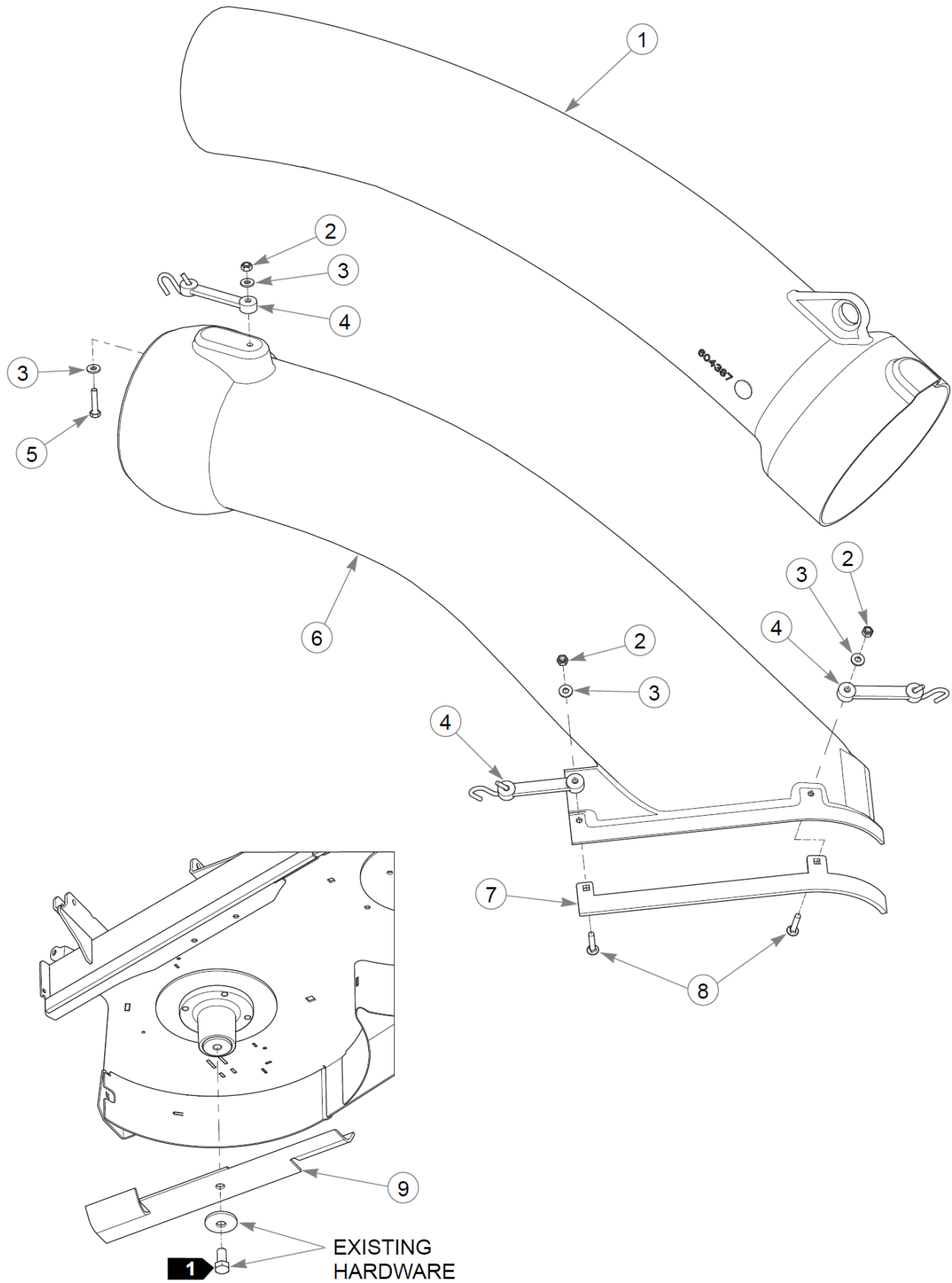



Item	Part No.	Qty	Name
1	604387	1	CATCHER CHUTE, LID SIDE
2	068551	3	NT .250-20 HXZY NL
3	768515	4	FW 0.281SAE
4	604475	3	BUNGEE
5	704916	1	CS .250-20X1.250HXG5
6	606932	1	RSD CATCHER CHUTE
7	124495-3	1	RSD CATCHER GUARD
8	606945	2	CB .250-20 X 1.50 FUL ZN
9	793935	1	BLADE,20.50"-CAT-F-CW
Not Shown	603848	1	BLADE, 17.86"-CAT-F-CW

Comments for Page: Catcher Chute & Blades

1. Torque to 118 ft-lbs (160 N•m).

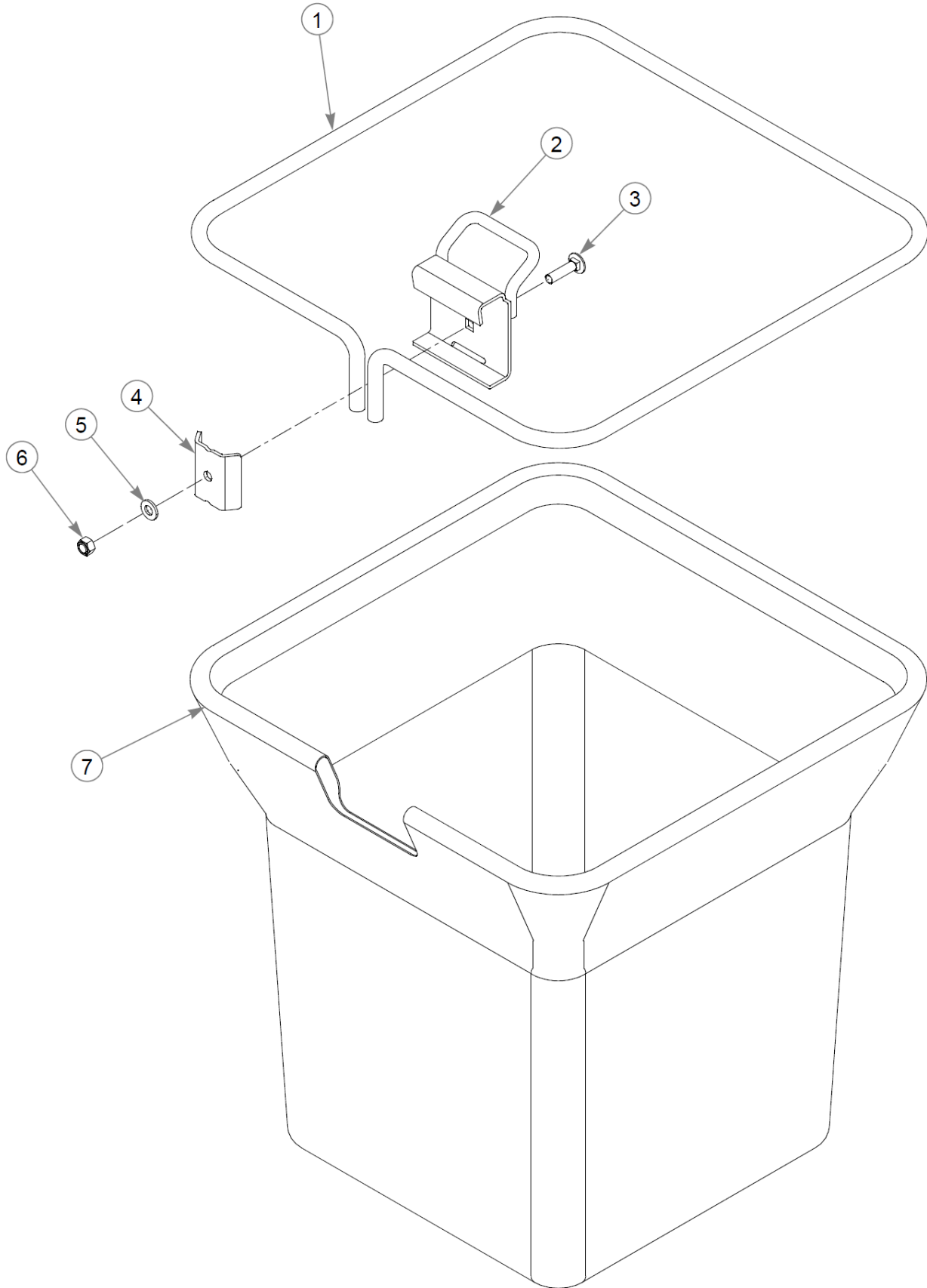

Item	Part No.	Qty	Name
Not Shown	552460	1	SVC CATCHER BAG
1	117393	1	BAG SUPPORT
2	117390	1	BAG CATCH
3	602827	1	CB .312-18X 1.250 ZN
4	117401	1	CLAMP BRACKET
5	768523	1	FW 0.343SAE
6	058776	1	NT .312-18NLG5
7	604389	1	1.6 BUSHEL BAG