

JETSON

Leo Folding Kick Scooter.

A guide for your ride.

IMPORTANT, RETAIN FOR FUTURE REFERENCE: READ CAREFULLY

MODEL: JLEO-BLU | JLEO-PNK | JLEO-RED | JLEO-GRN



**Remember to be safe and,
most importantly, have fun!**

Table of Contents

Safety Warnings	4
What's in the Box	6
Specs & Features	9
Unfolding / Folding the Leo	10
Assembly	13
Adjusting the Handlebar	14
Using the Brake	16
Riding the Leo	17
Helmet Safety	18
Care & Maintenance	19

Safety Warnings

- Before use, please read the user manual and safety warnings carefully, and make sure you understand and accept all the safety instructions. The user will be responsible for any loss or damage caused by improper use.
- Before each cycle of operation, the operator shall perform the preoperation checks specified by the manufacturer: That all guards and pads originally supplied by the manufacturer are in proper place and in serviceable condition; That the braking system is functioning properly; That any and all axle guards, chain guards, or other covers or guards supplied by the manufacturer are in place and in serviceable condition; That tires are in good condition, inflated properly, and have sufficient tread remaining; The area that the product is to be operated should be safe and suitable for safe operation.
- Components shall be maintained and repaired in accordance with the manufacturer's specifications and using only the manufacturer's authorized replacement parts with installation performed by dealers or other skilled persons.
- Warning against recharging non-rechargeable batteries.
- Don't allow hands, feet, hair, body parts, clothing, or similar articles to come in contact with moving parts, wheels, or drive train, while the motor is running.
- This product should not be used by children or persons with reduced physical, sensory or mental capabilities, or lack of experience and knowledge, unless they have been given supervision or instruction (IEC 60335-1/A2:2006).
- Unsupervised children should not play with the product (IEC 60335-1/A2:2006).
- Adult supervision is required.
- The rider should not exceed 132 lb.
- Units shall not be operated to perform racing, stunt riding, or other maneuvers, which may cause loss of control, or may cause uncontrolled operator/passenger actions or reactions.
- Never use near motor vehicles.
- Avoid sharp bumps, drainage grates, and sudden surface changes. Scooter may suddenly stop.
- Avoid streets and surfaces with water, sand, gravel, dirt, leaves, and other debris. Wet weather impairs traction, braking, and visibility.
- Avoid riding around flammable gas, steam, liquid, or dust that could cause fire.
- Operators shall adhere to all of the manufacturer's recommendations and instructions, as well as comply with all laws and ordinances: Units without headlights shall be operated only with adequate daylight conditions of visibility, and; Owners shall be encouraged to highlight (for conspicuity) using lighting, reflectors, and for low-riding units, signal flags on flexible poles.
- Persons with the following conditions shall be cautioned not to operate: Those with heart conditions; Pregnant women; Persons with head, back, or neck ailments, or prior surgeries to those areas of the body; and persons with any mental or physical conditions that may make them susceptible to injury or impair their physical dexterity or mental capabilities to recognize, understand, and perform all of the safety instructions and to be able to assume the hazards inherent in unit use.
- Do not ride at night.
- Do not ride after drinking or taking prescription medication.
- Do not carry items when riding.
- Never operate the product barefooted.
- Always wear shoes and keep shoelaces tied.
- Make sure your feet are always placed securely on the deck.
- Operators always shall use appropriate protective clothing, including but not limited to a helmet, with appropriate certification, and any other equipment recommended by the manufacturer: Always wear protective equipment such as helmet, knee pads, and elbow pads.
- Always give way to pedestrians.
- Be alert to things in front and far away from you.
- Do not allow distractions when riding, such as answering the phone or engaging in any other activities.
- The product cannot be ridden by more than one person.
- When you ride the product along with other riders, always keep a safe distance to avoid a collision.
- When turning, be sure to maintain your balance.
- Riding with improperly adjusted brakes is dangerous and can result in serious injury or death.
- The brake may become hot while operating, do not touch the brake with your bare skin.

- Applying brakes too hard or too suddenly can lock up a wheel, which could cause you to lose control and fall. Sudden or excessive application of the brake may result in injury or death.
- If the brake loosens, please adjust with the hexagon wrench, or please contact Jetson Customer Care.
- Replace worn or broken parts immediately.
- Check whether all safety labels are in place and understood before riding.
- The owner shall allow the use and operation of the unit after a demonstration that such operators can understand and operate all components of the unit before use.
- Do not ride without proper training. Do not ride at high speeds, on uneven terrain, or on slopes. Do not perform stunts or turn abruptly.
- Recommended for indoor use.
- Prolonged exposure to UV rays, rain and the elements may damage the enclosure materials, store indoors when not in use.

California Proposition 65

WARNING:

This product can expose you to a chemical such as Cadmium that is known to the state of California to cause cancer or birth defects or other reproductive harm. For more information go to www.p65warnings.ca.gov/product

MODIFICATIONS

Do not attempt to disassemble, modify, repair, or replace the unit or any components of the unit without instruction from Jetson Customer Care. This will void any warranty, and can lead to malfunctions which may cause injury.

ADDITIONAL OPERATION CAUTIONS

Do not lift the product off the ground while it is on and the wheels are in motion. This can result in freely spinning wheels, which may cause injury to yourself or others nearby. Do not jump on or off the product, and do not jump while using it. Always keep your feet firmly planted on the foot rest while in operation. Always check the battery charge before using.

What's in the Box

1. HANDLEBAR
2. STEM CLAMP
3. STEM
- 4 FRONT WHEEL
5. FOLDING LEVER
6. LOCKING LEVER
7. DECK
8. REAR FOOT BRAKE
9. REAR WHEEL

TOOLS INCLUDED:



*ADULTS MUST ASSIST CHILDREN IN THE INITIAL ADJUSTMENT PROCEDURES OF THE PRODUCT.

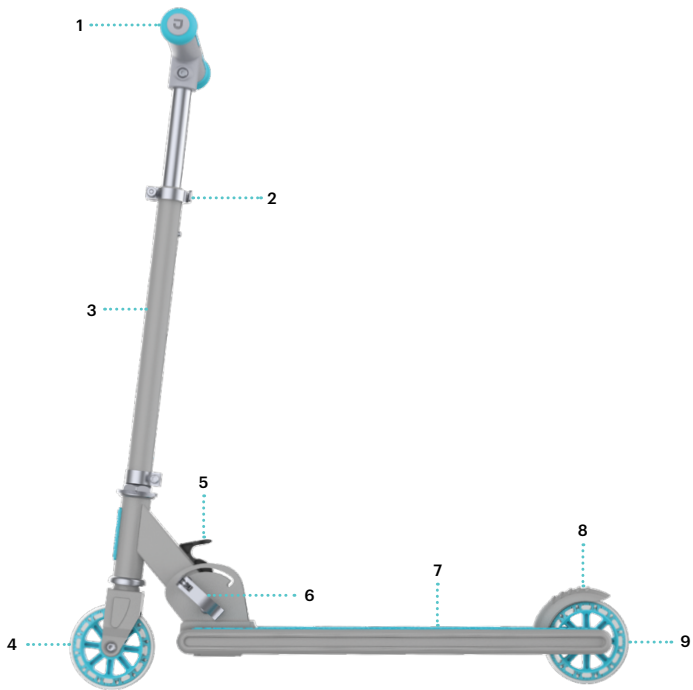

PLEASE NOTE: IMAGES MAY NOT REFLECT EXACT APPEARANCE OF ACTUAL PRODUCT.

Specs & Features

- WEIGHT LIMIT: 110 LB
- PRODUCT WEIGHT: 6 LB
- WHEEL SIZE: 4"
- FOLDED DIMS: 24.8" X 11.4" X 6"
- UNFOLDED DIMS: 24.8" X 11.4" X 27"
- DECK DIMS: 24" X 4"
- STEM HEIGHT: 27" - 31.5"
- RECOMMENDED AGE: 5+

1. Get Started

1.1 Unfolding / Folding the Leo

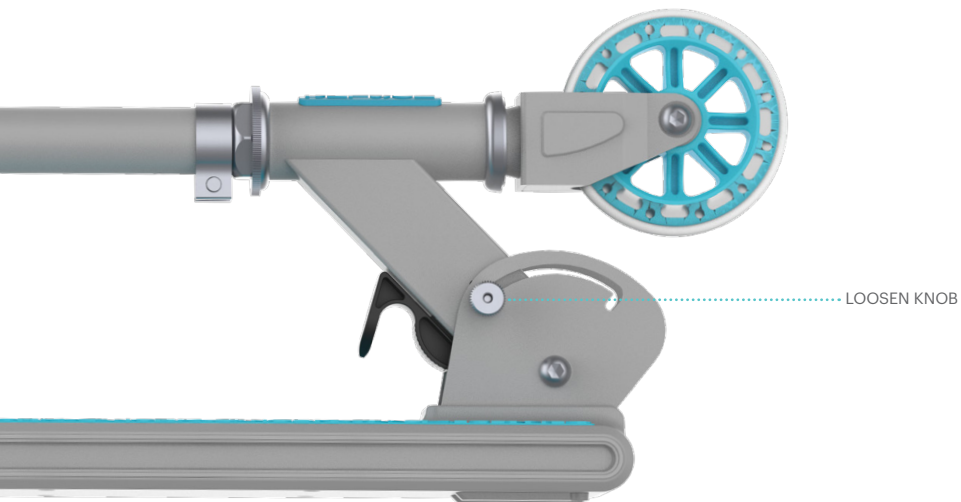

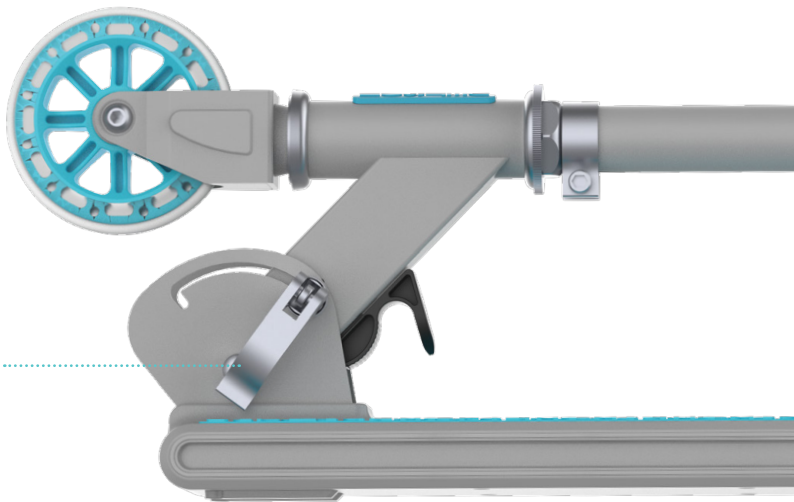

OPEN THE LOCKING LEVER
(LOCATED ON THE RIGHT
SIDE OF THE LEO)

- LIFT FOLDING LEVER AND RAISE STEM UP. ONCE YOU HEAR IT CLICK, IT'S FULLY UNFOLDED.
- TIGHTEN THE KNOB AND CLOSE THE LOCKING LEVER.
- REVERSE THESE STEPS TO FOLD THE LEO.

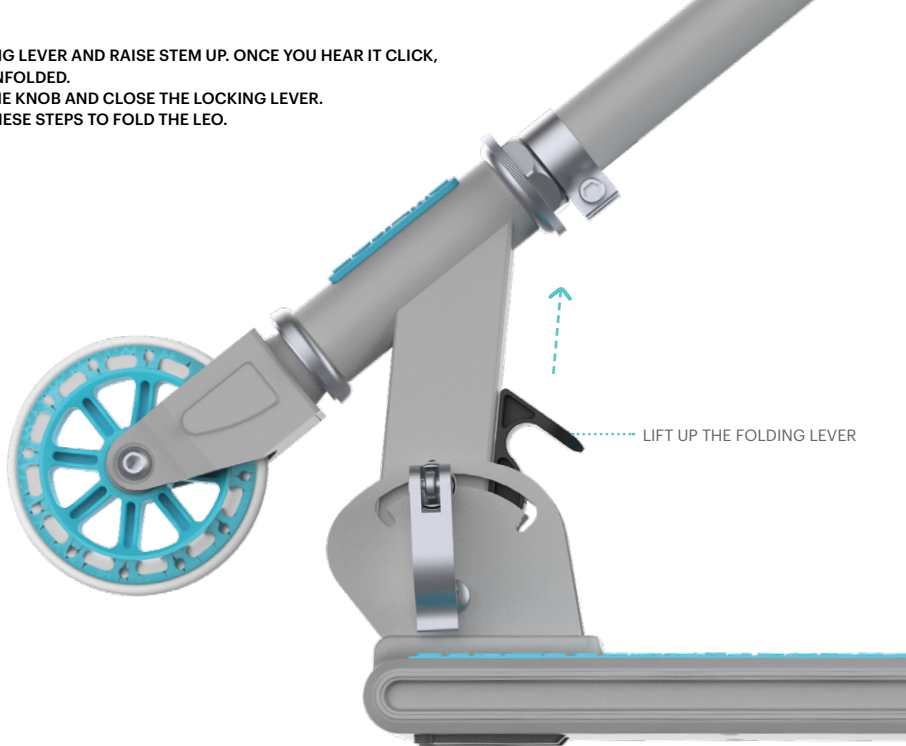

1.2 Assembly

- TIGHTEN USING BOLT AND NUT

NOTE: PLACE THE NUT ON THE RIGHT SIDE WHEN FACING THE FRONT OF THE LEO.

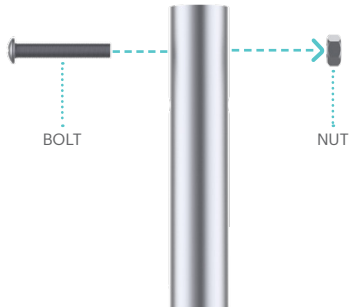
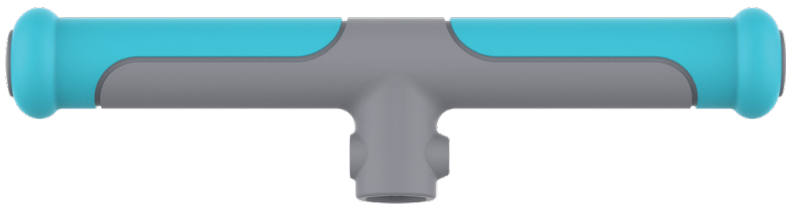



STEM CLAMP

BUTTON

1.3 Adjusting the Handlebar

- OPEN THE STEM CLAMP.
- WHILE PRESSING DOWN THE BUTTON, LIFT OR LOWER THE HANDLEBAR.

• WHEN YOU HEAR IT CLICK, TIGHTEN & CLOSE STEM CLAMP TO LOCK. MAKE SURE THE HANDLEBAR IS SECURE.

CAUTION: THE STEM PIN WILL NOT KEEP THE STEM SECURE, PLEASE MAKE SURE THE STEM CLAMP IS TIGHTENED AND CLOSED BEFORE RIDING.



1.4 Using the Brake

PRESS DOWN TO COME TO A COMPLETE STOP

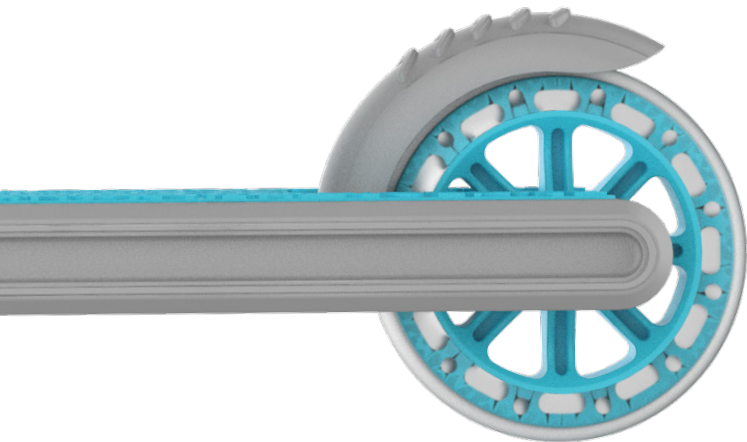

2. Make Moves

2.1 Riding the Leo

- PLACE ONE FOOT IN FRONT.
- PLACE THE OTHER FOOT IN BACK AT 70 - 90° ANGLE.
- TURN THE HANDLEBAR TO THE LEFT OR RIGHT TO MAKE TURNS.



2.3 Helmet Safety



THE FOREHEAD IS COVERED
BY THE HELMET.



THE FOREHEAD IS EXPOSED.
COULD CAUSE SERIOUS INJURY.

Care & Maintenance

CLEANING THE LEO

TO CLEAN THE LEO, CAREFULLY WIPE WITH A DAMP CLOTH, THEN DRY WITH A DRY CLOTH. DO NOT USE WATER TO CLEAN THE LEO, THIS MAY DAMAGE THE FRAME.

FEW MUST-DO'S

- KEEP AWAY FROM FIRE AND EXCESSIVE HEAT.
- AVOID INTENSE PHYSICAL IMPACT AND / OR SEVERE VIBRATION.
- PLEASE RIDE THE LEO ON A SMOOTH, FLAT SURFACE.
- PROTECT FROM WATER OR MOISTURE.
- CONTACT JETSON CUSTOMER CARE IF THERE ARE ANY ISSUES WITH THE LEO.

STORAGE

- STORE THE LEO INDOORS IN A DRY PLACE.
- COVER THE LEO TO PROTECT AGAINST DUST.

Enjoying the ride?

Leave a review on ridejetson.com/reviews or share your photos with us online using the #RideJetson hashtag!



Follow us **@ridejetson**
#MakeMoves

JETSON

Questions? Let us know.

support.ridejetson.com

Hours of Operation:
7 Days a Week, 10am-6pm

Manufactured by Yongkang, China
Imported by Jetson Electric Bikes LLC.
86 34th Street 4th Floor, Brooklyn, New York 11232

www.ridejetson.com



Made in China
Date Code: 09/2021