

JETSON

JLR M Light-Up Kids Bicycle.

A guide for your ride.

IMPORTANT, RETAIN FOR FUTURE REFERENCE: READ CAREFULLY

MODEL: JLUN16-BLK | JLUN16-PUR



**Remember to be safe and,
most importantly, have fun!**

Table of Contents

Safety Warnings	5
Safety Checklist	9
What's in the Box	10
Specs & Features	12
Training Wheels Assembly	13
Front Wheel Assembly	16
Handlebar Assembly	19
Inserting the Seat	21
Pedals Assembly	24
Battery Installation	27
LED Lights	29
Wheel Lights	30
Operating the Coaster Brake	32
Helmet Safety	33
Riding the JLR M	34
Care & Maintenance	35

Safety Warnings

- Before use, please read the user manual and safety warnings carefully, and make sure you understand and accept all the safety instructions. The user will be responsible for any loss or damage caused by improper use.
- Before each cycle of operation, the operator shall perform the preoperation checks specified by the manufacturer:
 - That all guards and pads originally supplied by the manufacturer are in proper place and in serviceable condition;
 - That the braking system is functioning properly;
 - That any and all axle guards, chain guards, or other covers or guards supplied by the manufacturer are in place and in serviceable condition;
 - That tires are in good condition, inflated properly, and have sufficient tread remaining; The area that the product is to be operated should be safe and suitable for safe operation.
- Components shall be maintained and repaired in accordance with the manufacturer's specifications and using only the manufacturer's authorized replacement parts with installation performed by dealers or other skilled persons.
- Don't allow hands, feet, hair, body parts, clothing, or similar articles to come in contact with moving parts, wheels, or drive train, while the bike is in use.
- This product should not be used by children or persons with reduced physical, sensory or mental capabilities, or lack of experience and knowledge, unless they have been given supervision or instruction (IEC 60335-1/A2:2006).
- Unsupervised children should not play with the product (IEC 60335-1/A2:2006).
- Adult supervision is required.
- The rider should not exceed 110 lb.
- Never use near motor vehicle.
- Units shall not be operated to perform racing, stunt riding, or other maneuvers, which may cause loss of control, or may cause uncontrolled operator/passenger actions or reactions.
- Avoid sharp bumps, drainage grates, and sudden surface changes. Bike may suddenly stop.
- Avoid streets and surfaces with water, sand, gravel, dirt, leaves, and other debris. Wet weather impairs traction, braking and visibility.
- Avoid riding around flammable gas, steam, liquid, or dust that could cause fire.
- Operators shall adhere to all of the manufacturer's recommendations and instructions, as well as comply with all laws and ordinances: Units without headlights shall be operated only with adequate daylight conditions of visibility, and; Owners shall be encouraged to highlight (for conspicuity) using lighting, reflectors, and for low-riding units, signal flags on flexible poles.
- Do not ride at night.
- Only ride the product with adequate daylight conditions for visibility.
- Persons with the following conditions shall be cautioned not to operate: Those with heart conditions; Pregnant women; Persons with head, back, or neck ailments, or prior surgeries to those areas of the body; and persons with any mental or physical conditions that may make them susceptible to injury or impair their physical dexterity or mental capabilities to recognize, understand, and perform all of the safety instructions and to be able to assume the hazards inherent in unit use.
- Do not ride after drinking or taking prescription medication.
- Do not carry items when riding.
- Never operate the product barefooted.
- Always wear shoes and keep shoelaces tied.

- Make sure your feet are always placed securely on the deck.
- Operators always shall use appropriate protective clothing, including but not limited to a helmet, with appropriate certification, and any other equipment recommended by the manufacturer: Always wear protective equipment such as helmet, knee pads, and elbow pads.
- Always give way to pedestrians.
- Be alert to things in front and far away from you.
- Do not allow distractions when riding, such as answering the phone or engaging in any other activities.
- The product cannot be ridden by more than one person.
- When you ride the product along with other riders, always keep a safe distance to avoid a collision.
- When turning, be sure to maintain your balance.
- Riding with improperly adjusted brakes is dangerous and can result in serious injury or death.
- Applying brakes too hard or too suddenly can lock up a wheel, which could cause you to lose control and fall. Sudden or excessive application of the brake may result in injury or death.
- If the brake loosens, please adjust with the hexagon wrench, or please contact Jetson Customer Care.
- Replace worn or broken parts immediately.
- The area that the product is to be operated should be safe and suitable for safe operation.
- Check whether all safety labels are in place and understood before riding.
- The owner shall allow the use and operation of the unit after a demonstration that such operators can understand and operate all components of the unit before use.
- Recommended for indoor use.
- Use caution when changing the batteries. Do not change batteries near flammable materials. Remove batteries from the bike when not in use for long periods of time.
- Prolonged exposure to UV rays, rain and the elements may damage the enclosure materials, store indoors when not in use.

MODIFICATIONS

Do not attempt to disassemble, modify, repair, or replace the product or any components of the unit without instruction from Jetson Customer Care. This will void any warranty, and can lead to malfunctions which may cause injury.

ADDITIONAL OPERATION CAUTIONS

- Do not lift the product off the ground while it is on and the wheels are in motion. This can result in freely spinning wheels, which may cause injury to yourself or others nearby.
- Do not jump on or off the product, and do not jump while using it.
- Always keep your feet firmly planted on the pedals while in operation.
- The Consumer Product Safety Commission advises that the riding of small wheel diameter bicycles at excessive speeds can lead to instability and is not recommended.
- Always wear a properly fitted helmet when you ride your bicycle. Do not ride at night. Avoid riding in wet conditions.

MAINTENANCE CAUTIONS

For all maintenance repairs and needs beyond the capability of the consumer which may include but not limited to such as proper maintenance of brakes, control cables, bearing adjustments, wheel adjustments, lubrication, reflectors, tires and handlebar and seat adjustments, please contact Jetson Customer Care for assistance at:

support.ridejetson.com

US & Canada 1-(888) 976-9904

Hours of Operation: 7 days a week 10am-6pm EST

DISPOSAL OF USED BATTERY



Battery may contain hazardous substances which could endanger the environment and human health. This symbol marked on the battery and/ or packaging indicates that used battery shall not be treated as municipal waste. Batteries should be disposed of at an appropriate collection point for recycling. By ensuring the used batteries are disposed of correctly, you will help preventing potential negative consequences for the environment and human health. The recycling of materials will help to conserve natural resources. For more information about recycling of used batteries, please contact your local municipality waste disposal service.

California Proposition 65



This product can expose you to a chemical such as Cadmium that is known to the state of California to cause cancer or birth defects or other reproductive harm. For more information go to www.p65warnings.ca.gov/product

LIMITED LIFETIME WARRANTY

Limited Life Time Warranty only applies to the Frame & Fork for manufacture defects. Contact Jetson Customer Care for detailed information via support.ridejetson.com

Limited Lifetime Warranty does NOT cover:

- Normal wear and tear
- Improper assembly
- Corrosion
- Improper maintenance
- Installation of components, parts, or accessories not originally intended for or compatible with the bicycle as sold
- Damage or failure due to accident, misuse, abuse, or neglect
- Labor charges for part replacement or changeover
- Non-proprietary products (any other original part or component) covered by the original manufacturer's warranty
- Any accessories, brakes, tires

Safety Checklist

IT'S ALWAYS IMPORTANT TO DO A FEW BUT IMPORTANT SAFETY CHECKS BEFORE EVERY RIDE.
LET'S GO THROUGH THEM:

BRAKES

CHECK THE BRAKE IS IN GOOD WORKING ORDER. MAKE SURE PEDALS ROTATE BACKWARDS SMOOTHLY AND THAT THE REAR AXLE IS LUBRICATED.

STEERING

CHECK THAT THE HANDLEBAR AND STEM ARE SECURELY TIGHTENED.

CRANKS AND PEDALS

CHECK THAT THE PEDALS ARE SECURELY TIGHTENED TO THE CRANKS AND THAT THE CRANKS ARE TIGHTENED TO THE AXLE.

WHEELS AND TIRES

MAKE SURE THAT THE TIRES ARE INFLATED TO WITHIN THEIR MAXIMUM RECOMMENDED TIRE PRESSURE. CHECK TIRES FOR EXCESSIVE WEAR OR ANY DAMAGE AND THAT THE WHEEL RIMS ARE NOT DAMAGED. CHECK THAT THE WHEEL SPOKES ARE NOT BROKEN AND THAT THE AXLE NUTS ARE TIGHT.

CHAIN

MAKE SURE ALL BEARINGS ARE LUBRICATED AND RUN SMOOTHLY.

FRAME AND FORK

CHECK THAT THE FRAME AND FORK ARE NOT IN ANY WAY DAMAGED OR BROKEN.

What's in the Box

1. BIKE FRAME
2. TRAINING WHEELS (2X)
3. FRONT WHEEL
4. HANDLEBAR
5. SEAT
6. PEDALS (2X)
7. WHITE VALVE LED LIGHTS (2X)
8. MULTICOLOR VALVE LED LIGHTS (2X)

TOOLS INCLUDED:



DOUBLE-SIDED WRENCH

*ADULTS MUST ASSIST CHILDREN IN THE INITIAL ADJUSTMENT PROCEDURES OF THE PRODUCT.

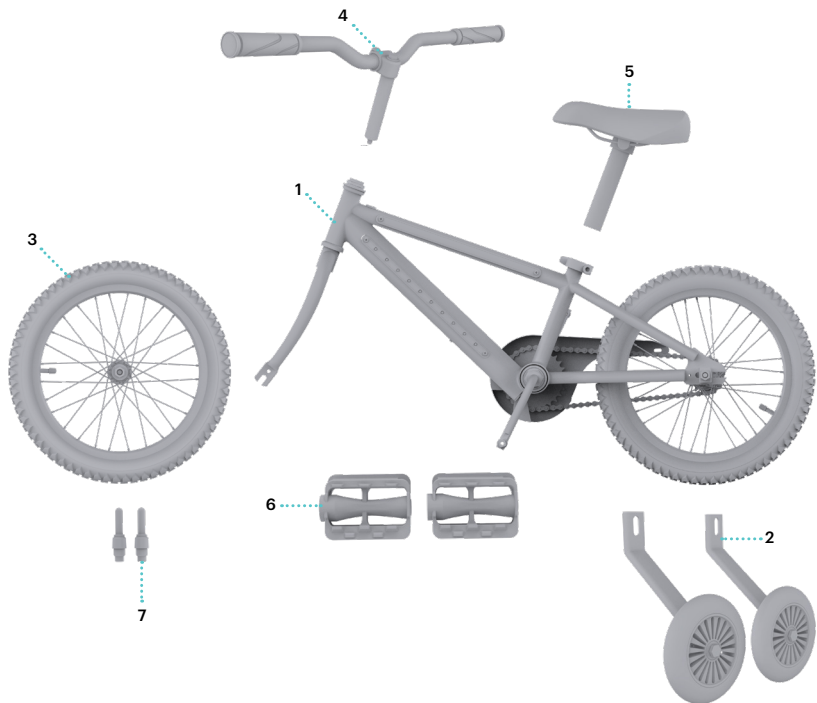

Specs & Features

- PRODUCT DIMENSIONS: 47" x 21" x 28.5"
- PRODUCT WEIGHT: 22 LB
- TIRE SIZE: 16 IN
- BATTERY: 3AA
- BRAKE TYPE: COAST BRAKE
- WEIGHT LIMIT: 110 LB
- RECOMMENDED AGE: 3+

Correct Frame Size

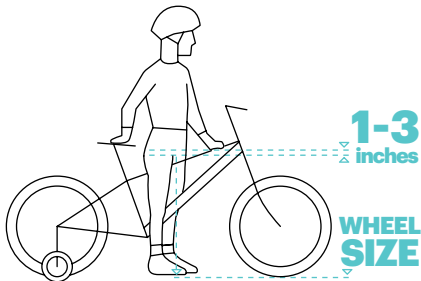

FOR SAFE AND COMFORTABLE RIDING THERE SHOULD BE A CLEARANCE OF AT LEAST 1-3 INCHES BETWEEN THE CROTCH AND THE TOP TUBE OF THE BICYCLE FRAME, WHILE THE RIDER STRADDLES THE BICYCLE WITH BOTH FEET FLAT ON THE GROUND.

⚠ WARNING:

FAILURE TO COMPLY WITH THE FOLLOWING INSTRUCTIONS MAY RESULT IN INJURY TO THE CHILD OR OTHERS.

- KEEP SMALL PARTS AWAY FROM CHILDREN DURING ASSEMBLY.
- ACCESSORY MUST BE ASSEMBLED AND REMOVED BY AN ADULT.
- FREQUENTLY INSPECT THE PRODUCT FOR DAMAGE.

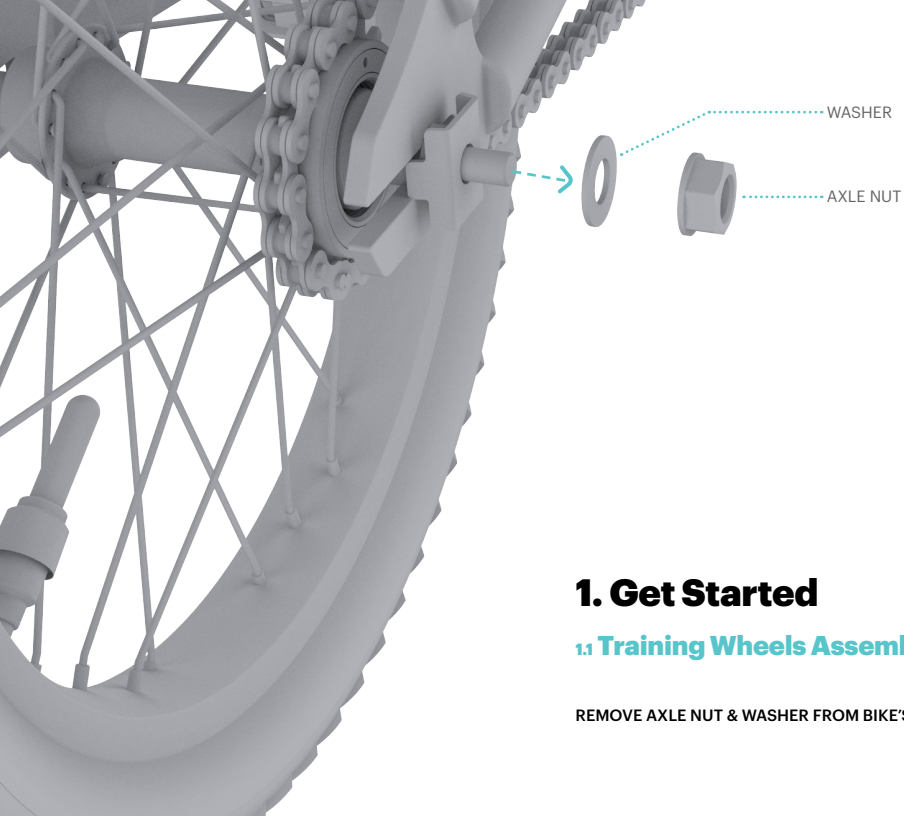

1. Get Started

1.1 Training Wheels Assembly

REMOVE AXLE NUT & WASHER FROM BIKE'S REAR WHEEL

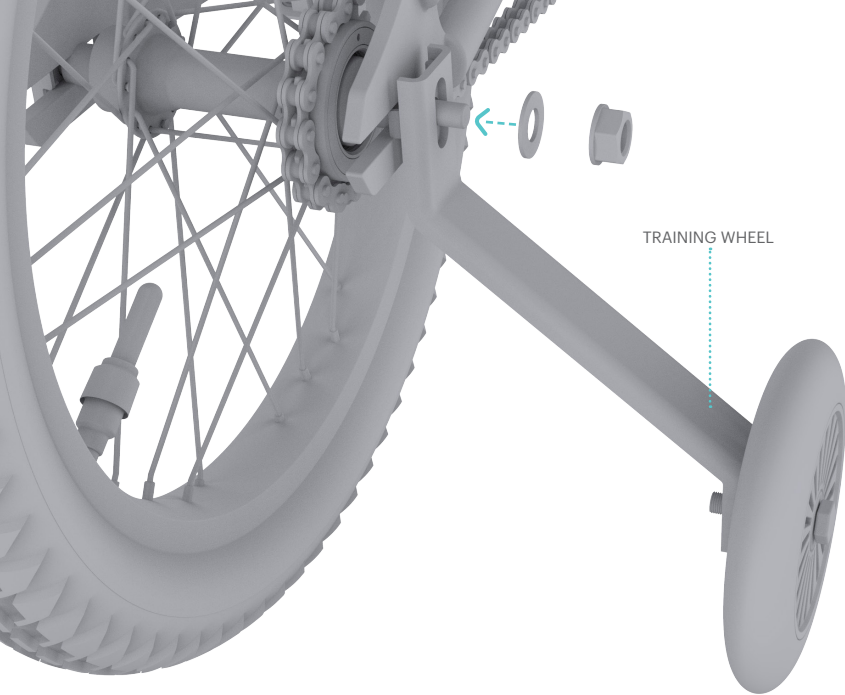

- PLACE TRAINING WHEEL BRACKET ONTO THE AXLE
- PLACE WASHER & AXLE NUT ONTO WHEEL BRACKET AND TIGHTEN SECURELY

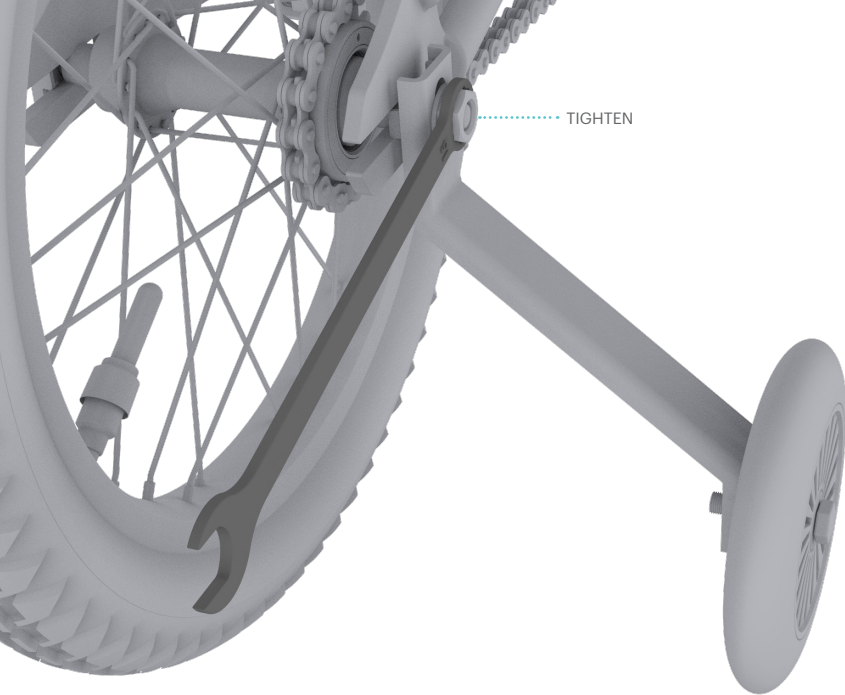

TIGHTEN

• REPEAT ON THE OTHER SIDE OF THE BICYCLE. ONCE BOTH BRACKETS ARE CONNECTED, TIGHTEN SECURELY

1.2 Front Wheel Assembly



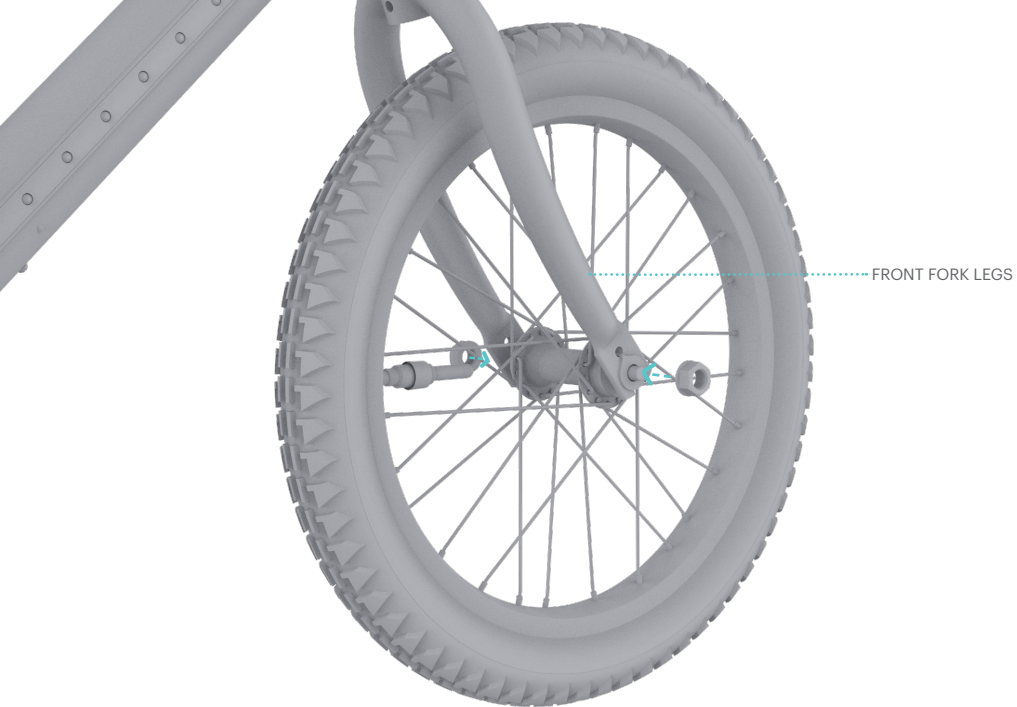

FRONT FORK LEGS

- PLACE WHEEL BETWEEN THE FRONT FORK LEGS
- MAKE SURE THE WHEEL IS CENTERED AND THAT THE AXLE FITS INTO THE WEDGES OF THE FORK LEGS

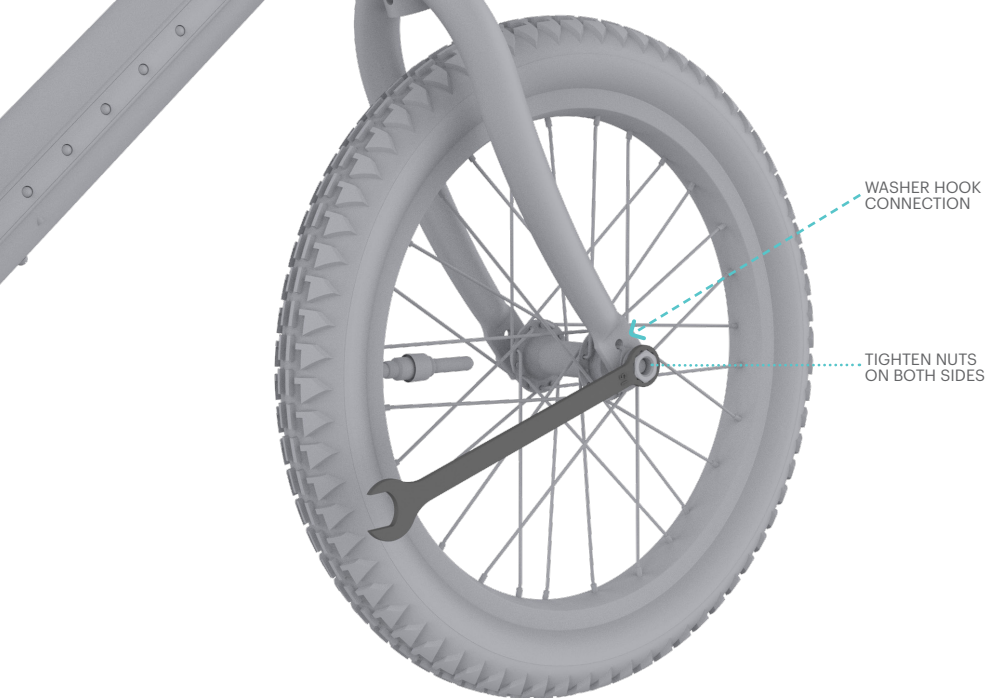

WASHER HOOK
CONNECTION

TIGHTEN NUTS
ON BOTH SIDES

- CONNECT HOOK ON THE WASHER INTO THE HOLE ON AXLE.
- TIGHTEN NUT
- REPEAT ON THE OTHER SIDE OF THE AXLE

1.3 Handlebar Assembly

- ADJUST HEIGHT TO SUIT THE SIZE OF THE RIDER
- MAKE SURE THAT THE "MIN INSERTION" MARK IS NOT SHOWING

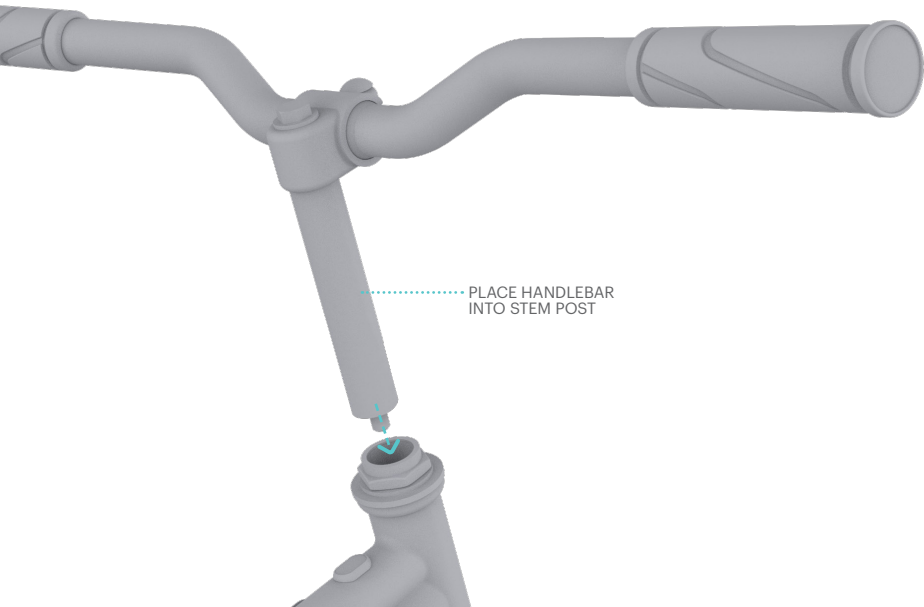

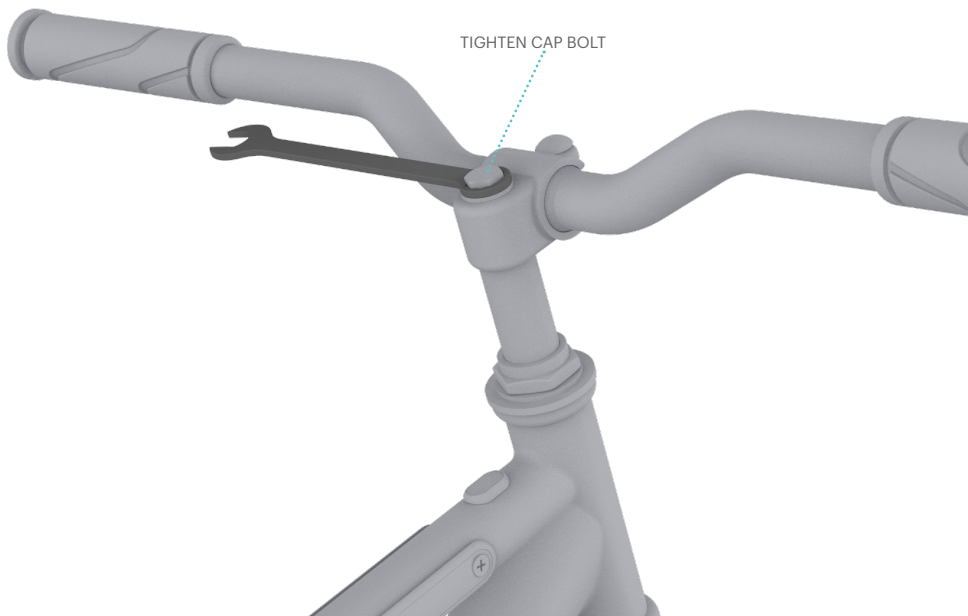

TIGHTEN CAP BOLT

1.3 Inserting the Seat

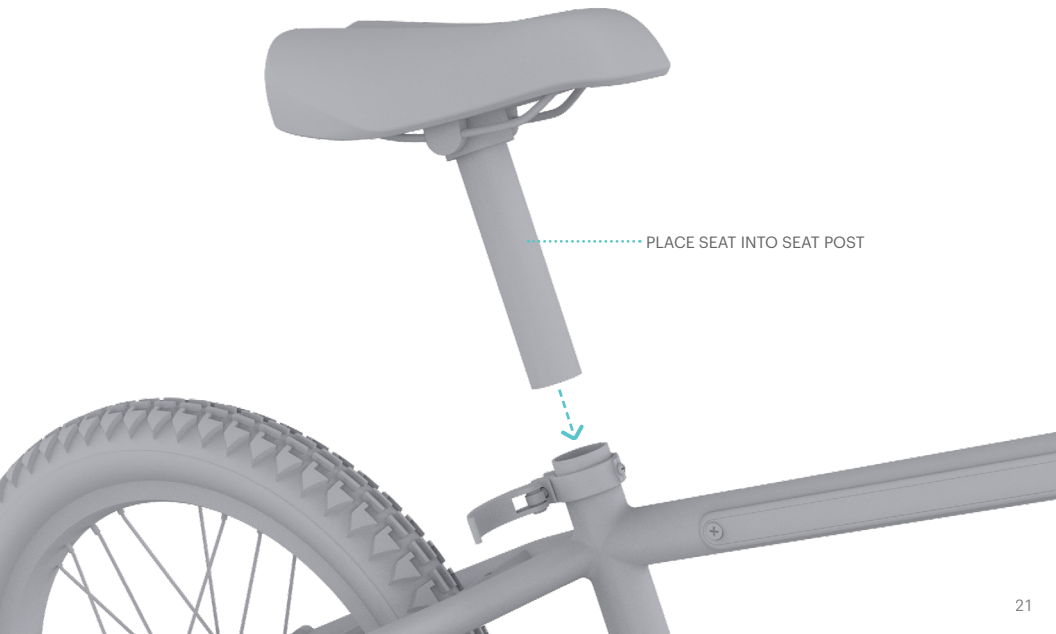

PLACE SEAT INTO SEAT POST

- ADJUST HEIGHT TO SUIT THE SIZE OF THE RIDER
- MAKE SURE THAT THE "MIN INSERTION" MARK IS NOT SHOWING

TIGHTEN & CLOSE
SEAT CLAMP

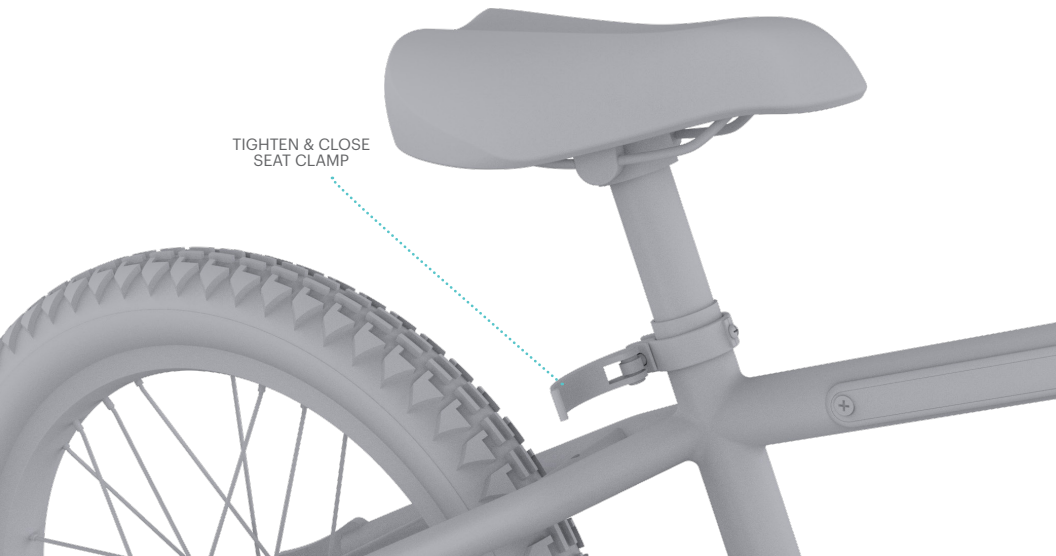



MAKE SURE SEAT CLAMP IS
SECURED AND SEAT IS STABLE

1.3 Pedals Assembly

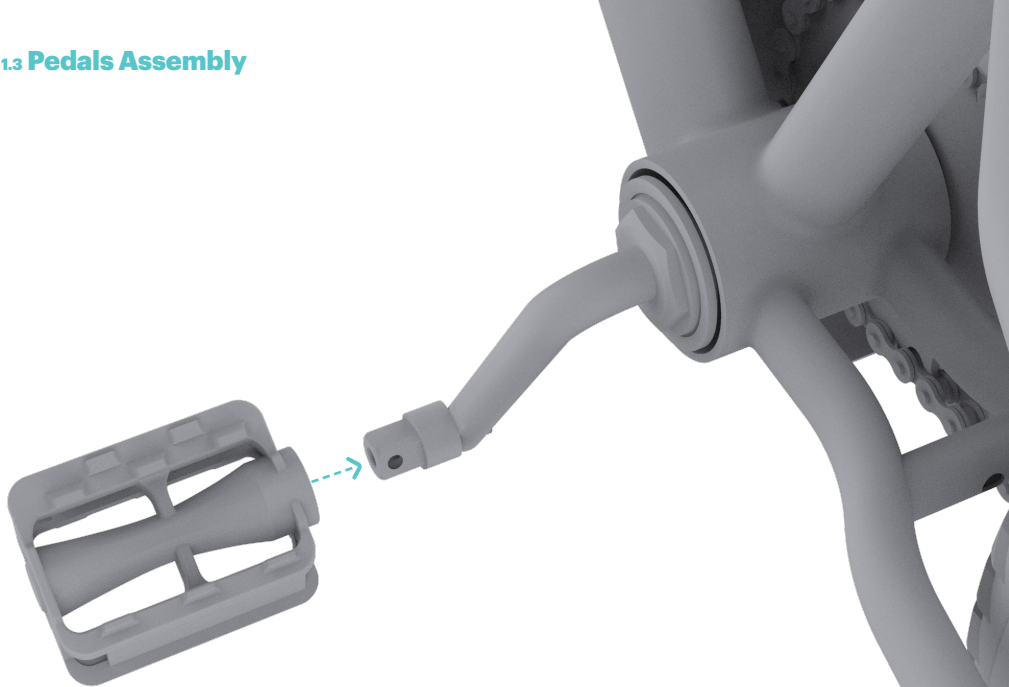

INSERT PEDAL MARKED "R" INTO THE RIGHT-HAND CRANK ARM

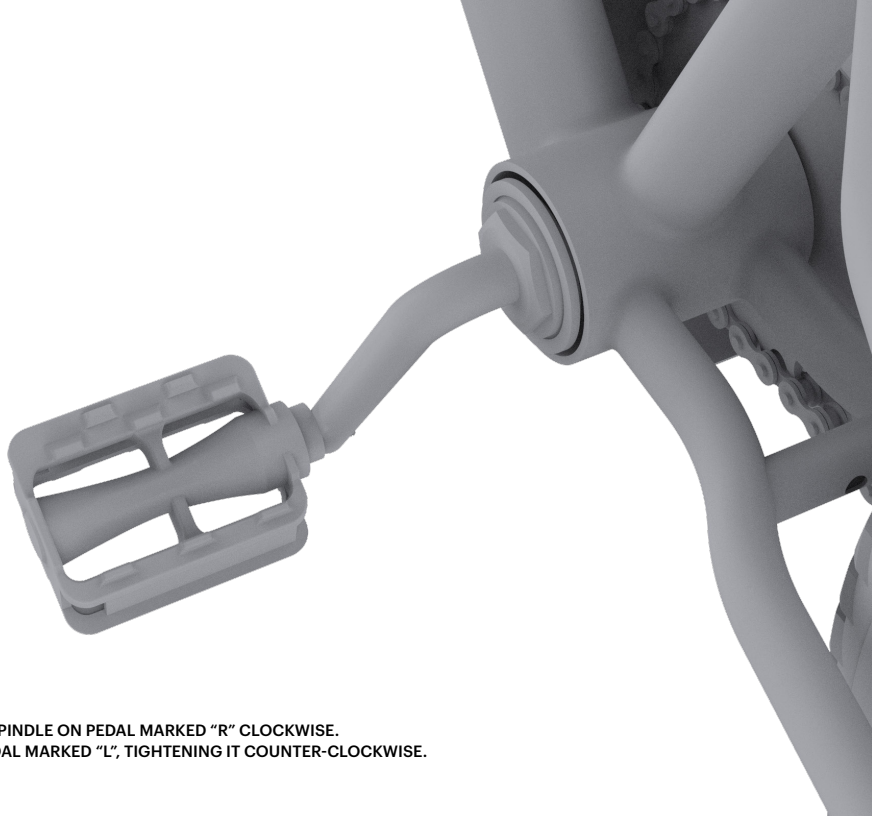

**HAND TIGHTEN SPINDLE ON PEDAL MARKED "R" CLOCKWISE.
REPEAT WITH PEDAL MARKED "L", TIGHTENING IT COUNTER-CLOCKWISE.**

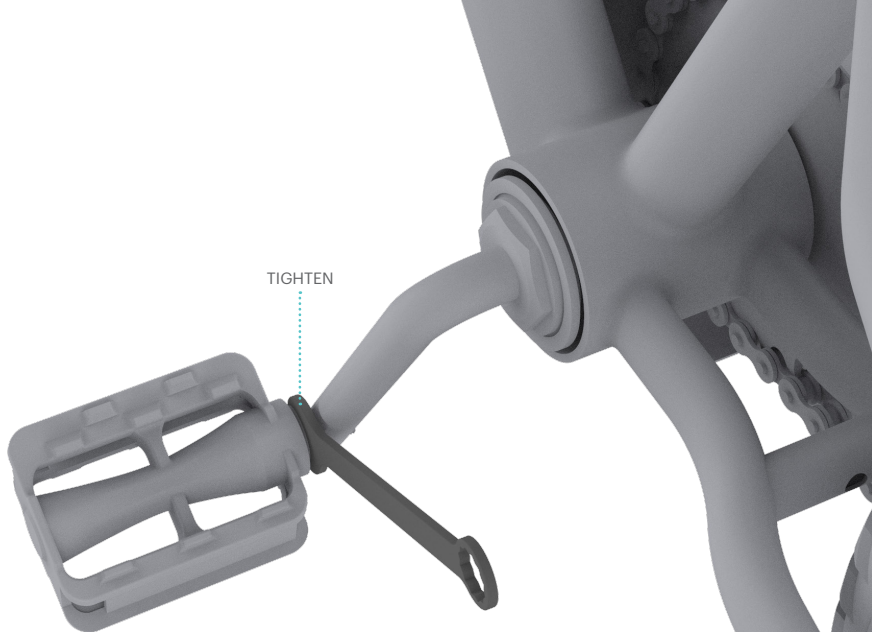

TIGHTEN

ONCE BOTH PEDALS ARE ON, TIGHTEN WITH WRENCH.

CAUTION: IT'S IMPORTANT TO STOP IF YOU FEEL RESISTANCE WHEN PUTTING ON THE PEDALS. IT COULD MEAN THE SPINDLE IS ENTERING THE CRANK ARM AT AN ANGLE.

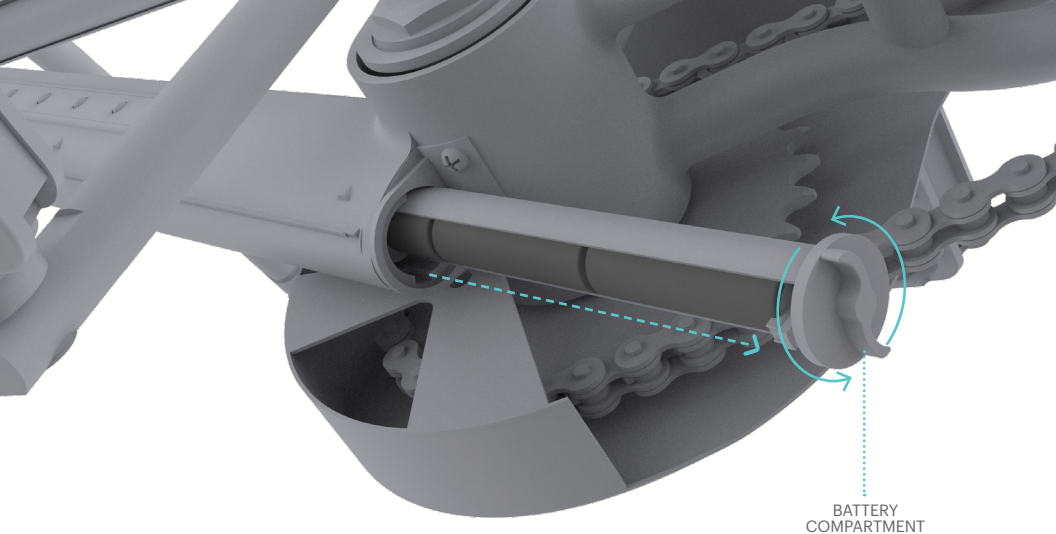

BATTERY
COMPARTMENT

2. Light Assembly

2.1 Battery Installation

TWIST TO UNLOCK BATTERY COMPARTMENT. INSERT BATTERIES.

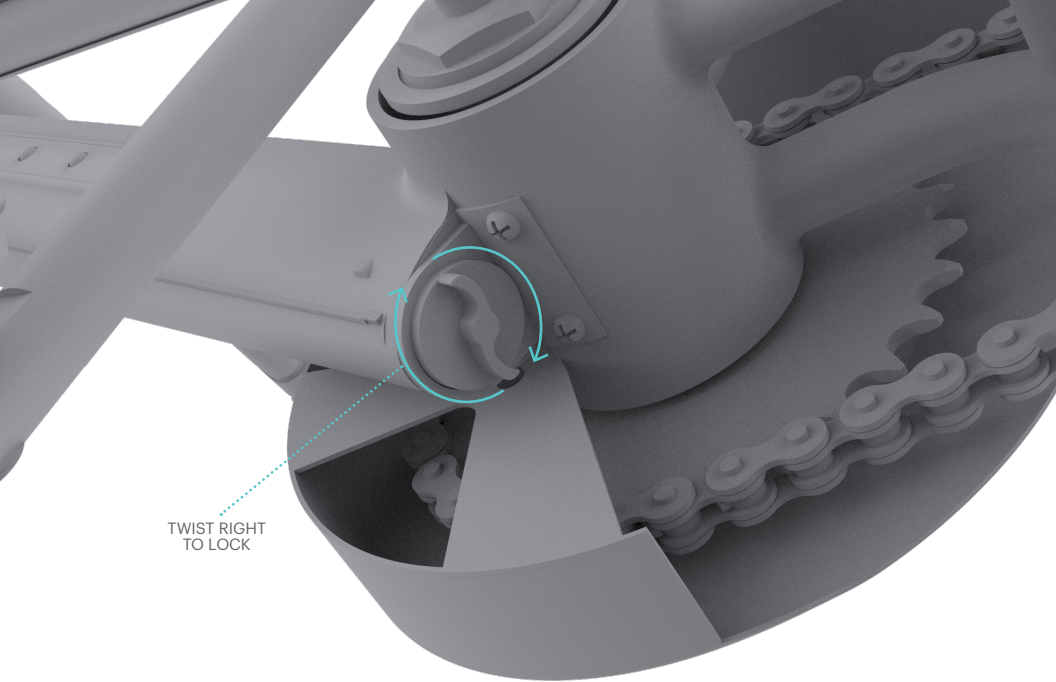

TWIST RIGHT
TO LOCK



2.2 LED Lights

- PRESS POWER BUTTON FOR 2 SECONDS TO CHANGE LIGHT MODE.
- TO CHANGE THE COLOR PATTERN PRESS POWER BUTTON QUICKLY.
- HOLD FOR 5 SECONDS TO TURN ON/OFF.

PLEASE NOTE: TO CONSERVE BATTERY POWER, LIGHTS WILL AUTOMATICALLY TURN OFF AFTER 10 MINUTES. PRESS POWER BUTTON TO TURN LIGHTS BACK ON.

..... POWER BUTTON

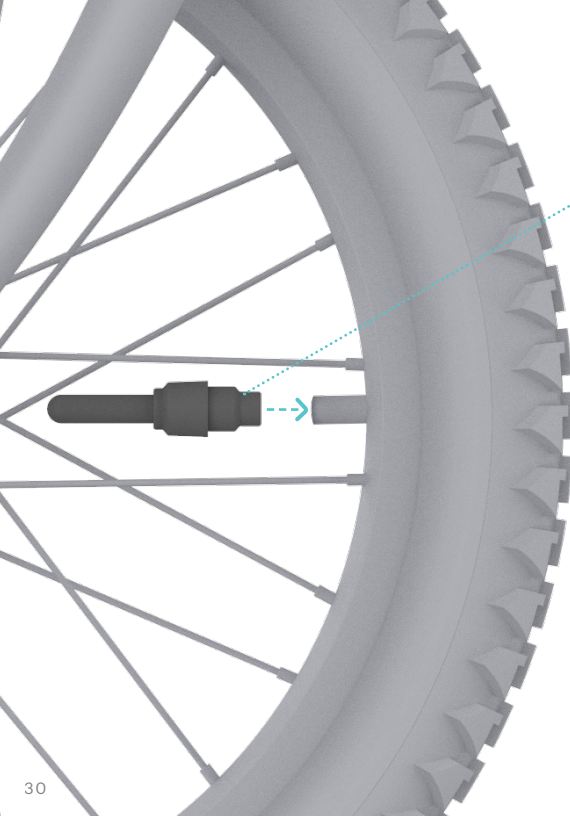

VALVE LED LIGHT

2.3 Wheel Light

TO ACTIVATE VALVE LIGHT:

- SCREW OFF TOP OF VALVE LIGHT.
- REMOVE PAPER COVERING 3 BATTERIES (AG10, 1.5V).
- SCREW BACK ON TOP OF VALVE LIGHT.

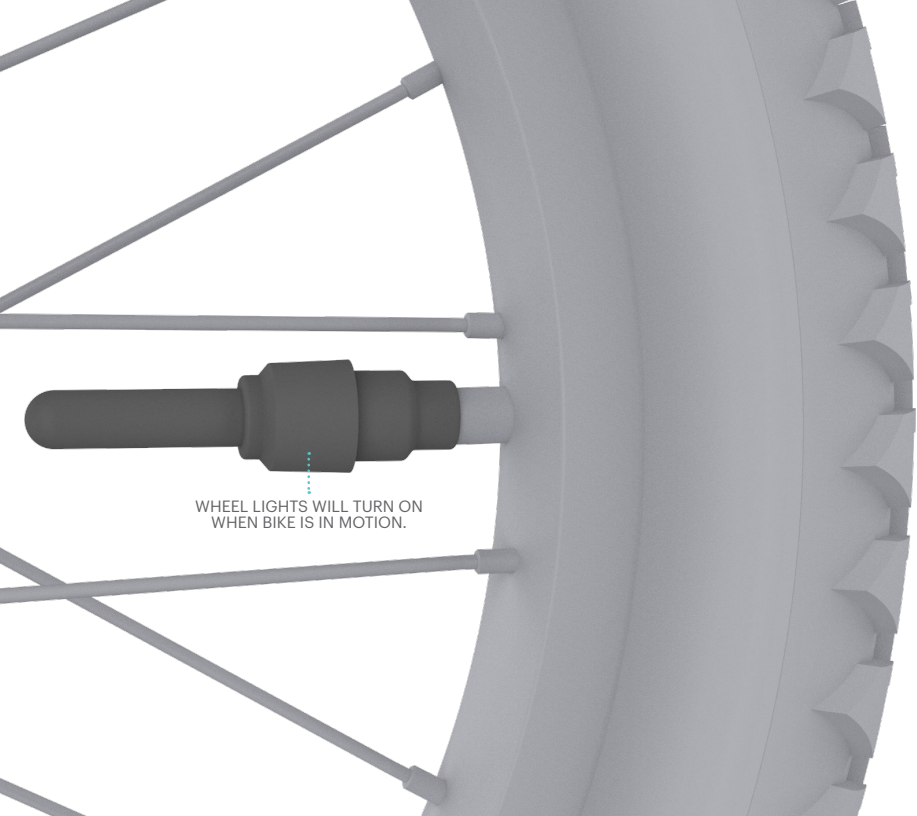

WHEEL LIGHTS WILL TURN ON
WHEN BIKE IS IN MOTION.

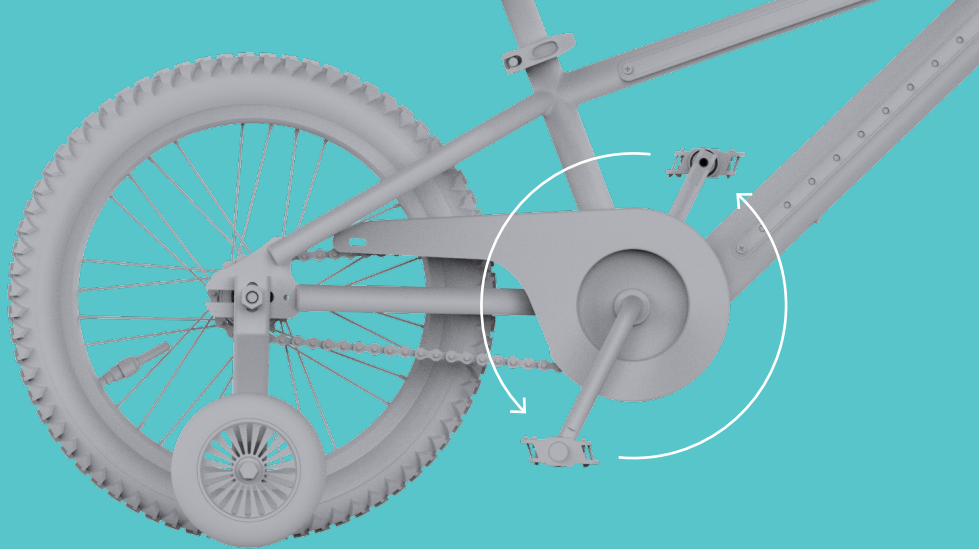

3. Make Moves

3.1 Operating the Coaster Brake

PEDAL IN REVERSE TO ENGAGE COASTER BRAKE. THE FASTER YOU PEDAL BACKWARDS, THE QUICKER THE BRAKING ACTION OF THE COASTER BRAKE WILL BE.

3.2 **Helmet Safety**



THE FOREHEAD IS COVERED
BY THE HELMET.



THE FOREHEAD IS EXPOSED.
COULD CAUSE SERIOUS INJURY.



3.3 Riding the JLR M

NOW YOU HAVE YOUR JLR M SAFELY ASSEMBLED, IT'S TIME TO RIDE OUT AND LIGHT UP THE WORLD.

PLEASE NOTE: IMAGES MAY NOT REFLECT EXACT APPEARANCE OF ACTUAL PRODUCT.

Care & Maintenance

CLEANING THE JLR M

- Carefully wipe with a damp cloth, then dry with a dry cloth.
- Do not use water to clean the JLR M, as the electrical and electronic systems may get wet, resulting in personal injury or malfunction of the JLR M.

BATTERY

- Keep away from fire and excessive heat.
- Avoid intense physical impact and / or severe vibration.
- Protect from water or moisture.
- Do not disassemble.
- If there are any issues with the battery, please contact Jetson Customer Care. We'd love to help!

STORAGE

- Remove batteries before storing.
- Cover to protect against dust.
- Store indoors, in a dry place and at a suitable temperature.

CHAIN ADJUSTMENT

The chain must remain on the sprockets. If the chain comes off the sprockets, the coaster brake will not operate.

ADJUSTMENT:

- The chain must be at the correct tightness.
- If too tight, the bicycle will be difficult to pedal.
- If too loose, the chain can come off the sprockets.

When the chain (C) is at the correct tightness, you can rotate the crank freely and you can pull it no more than one-half inch (A) away from a straightedge (B) as shown.

Adjust the tightness of the chain as follows:

- Loosen the axle nuts of the rear wheel.
- Move the rear wheel forward or backward as necessary.

NOTE: Make sure the rear wheel is in the center of the bicycle frame.

- Hold the wheel in this position and tighten the axle nuts.

WARNING:

Do not attempt chain repairs. If there is a problem with the chain, have a bicycle service shop make any repairs.

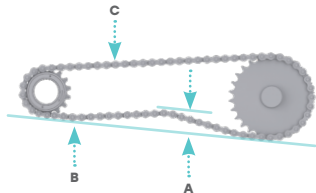

Enjoying the ride?

Leave a review on ridejetson.com/reviews or share your photos with us online using the #RideJetson hashtag!



Follow us **@ridejetson**
#MakeMoves

JETSON

Questions? Let us know.

support.ridejetson.com

Hours of Operation:
7 Days a Week, 10am-6pm

Imported by Jetson Electric Bikes LLC.
86 34th Street 4th Floor, Brooklyn, New York 11232

www.ridejetson.com



Made in China
Date Code: 07/2021