

JETSON

Rear Basket for the Haze Electric Bike*

A guide for your accessory.

IMPORTANT: READ CAREFULLY AND RETAIN FOR FUTURE REFERENCE.

MODEL: JHBSKT-BLK

*COMPATIBLE ONLY WITH THE JETSON HAZE ELECTRIC BIKE (MODEL: JHAZE)



**Jetson's top two riding rules:
Be safe. Have fun!**

Contents

Safety Warnings	4
What's in the Box	6
Product Specs & Care	8
Warranty Coverage	8
Online Resources	9
Basket Assembly & Attachment	
Attaching the Bracket	10
Attaching the Basket	14
Using the Basket	20

Safety Warnings

- Before use, please read the user manual and safety warnings carefully, and make sure you understand and accept all the safety instructions. The user will be responsible for any loss or damage caused by improper use.
- Components shall be maintained and repaired in accordance with the manufacturer's specifications and using only the manufacturer's authorized replacement parts with installation performed by dealers or other skilled persons.
- This product should not be used by children or persons with reduced physical, sensory or mental capabilities, or lack of experience and knowledge, unless they have been given supervision or instruction (IEC 60335-1/A2:2006).
- Unsupervised children should not play with the product (IEC 60335-1/A2:2006).
- Adult supervision is required.
- The max load capacity should not exceed 25 lb.
- Replace worn or broken parts immediately.
- The owner shall allow the use and operation of the unit after a demonstration that such operators can understand and operate all components of the unit before use.

MODIFICATIONS

Do not attempt to disassemble, modify, repair, or replace the product or any components of the unit without instruction from the Jetson Care Team. This will void any warranty, and can lead to malfunctions which may cause injury.

California Proposition 65



WARNING:

This product can expose you to chemicals including Chromium (hexavalent compounds), which is known to the State of California to cause cancer and birth defects or other reproductive harm. For more information go to: www.P65warnings.ca.gov.

What's in the Box

1. BASKET
2. BRACKET
3. ELASTIC STRAP

TOOLS & HARDWARE:



WASHER

(X9, INCLUDING 1 SPARE)



SCREW

(X9, INCLUDING 1 SPARE)



4MM ALLEN KEY

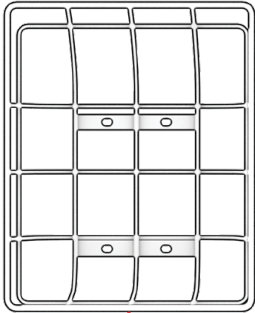

1

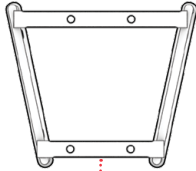

2

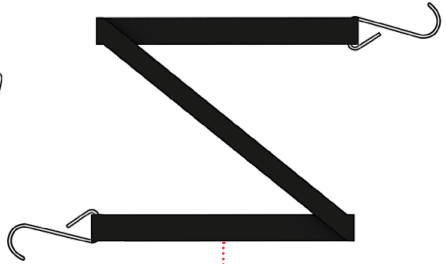

3

Product Specs & Care

- BASKET DIMENSIONS: 10.63" (L) X 8.66" (W) X 11.42" (H)
- WEIGHT: 3.1 LBS
- MAX CARRYING LOAD: 25 LBS
- MATERIAL: STEEL
- COMPATIBILITY: DESIGNED FOR USE WITH THE JETSON HAZE FOLDING ELECTRIC BIKE.
(MODELS JHAZE-BLK AND JHAZE-BLK-RA)

CARE: TO CLEAN YOUR BASKET, WIPE FIRST WITH A DAMP CLOTH AND THEN WITH A DRY CLOTH.

Warranty Coverage

GENERAL LIMITED WARRANTY

Your new Jetson product is warranted against defects in materials and workmanship as indicated on ridejetson.com/warranty for a period of time from the date of original retail purchase when used in accordance with Jetson's user manuals (refer to ridejetson.com/support). **Under this warranty, you will be able to direct your claims to Jetson even in situations where you purchased the Jetson Product from one of our authorized retailers.** To read the full terms of our warranty, visit ridejetson.com/warranty.

Online Resources

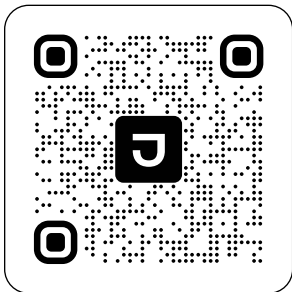

Scan for our most updated onboarding materials and support resources.

⚠️WARNING:

FAILURE TO COMPLY WITH THE FOLLOWING INSTRUCTIONS MAY RESULT IN INJURY TO THE CHILD OR OTHERS.

- KEEP SMALL PARTS AWAY FROM CHILDREN DURING ASSEMBLY.
- ACCESSORY MUST BE ASSEMBLED AND REMOVED BY AN ADULT.
- FREQUENTLY INSPECT THE PRODUCT FOR DAMAGE.

* ADULTS MUST ASSIST CHILDREN IN THE ASSEMBLY AND INITIAL ADJUSTMENT PROCEDURES OF THE PRODUCT.

Basket Assembly & Attachment

NOTE: THE DIRECTIONS GIVEN IN THIS MANUAL—RIGHT, LEFT, FRONT/ FORWARD, AND REAR/BACK—ARE ORIENTED AS THE RIDER WOULD SEE THEM WHEN SITTING ON THE BIKE. THE "RIGHT SIDE" OF THE BIKE AND BASKET, FOR EXAMPLE, IS THE SIDE WHERE THE RIDER'S RIGHT HAND AND FOOT WILL BE.

Attaching the Bracket

1. REMOVE THE 2 PLASTIC PLUGS IN THE TOP OF THE CHAINSTAY ON BOTH SIDES OF THE BIKE. DISCARD THE PLUGS OR STORE THEM FOR FUTURE USE IF YOU WOULD LIKE TO POP THEM BACK IN IF YOU EVER REMOVE THE BASKET FROM THE BIKE. (THEY ARE NOT NECESSARY.)

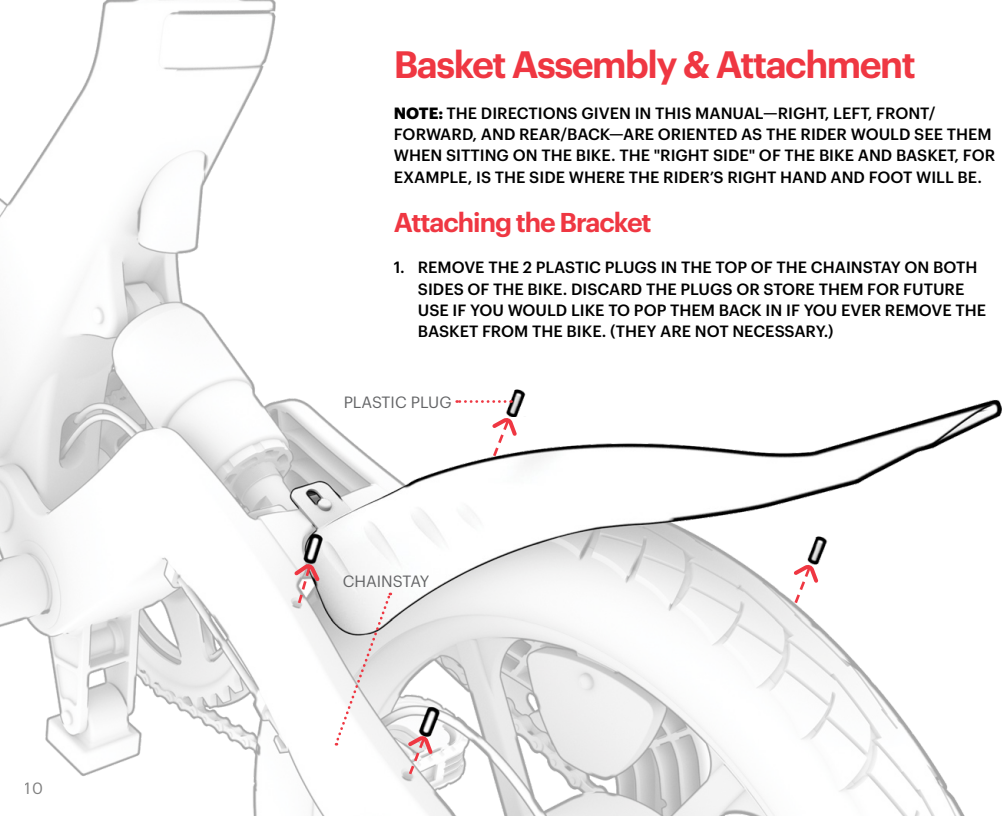

2. POSITION THE BRACKET OVER THE REAR FENDER SUCH THAT THE FOLLOWING CONDITIONS ARE MET:

- THE BRACKET FEET ARE RESTING ON TOP OF THE CHAIN STAYS WITH THE LONGER LEGS AT THE REAR OF THE BIKE AND THE SHORTER LEGS CLOSER TO THE SEAT.
- THE TWO HOLES IN EACH BRACKET FOOT ARE ALIGNED WITH THE HOLES IN THE CHAIN STAYS FROM WHICH YOU JUST REMOVED THE PLASTIC PEGS.
- THE TOP OF THE BRACKET IS FLAT AND PARALLEL TO THE GROUND.

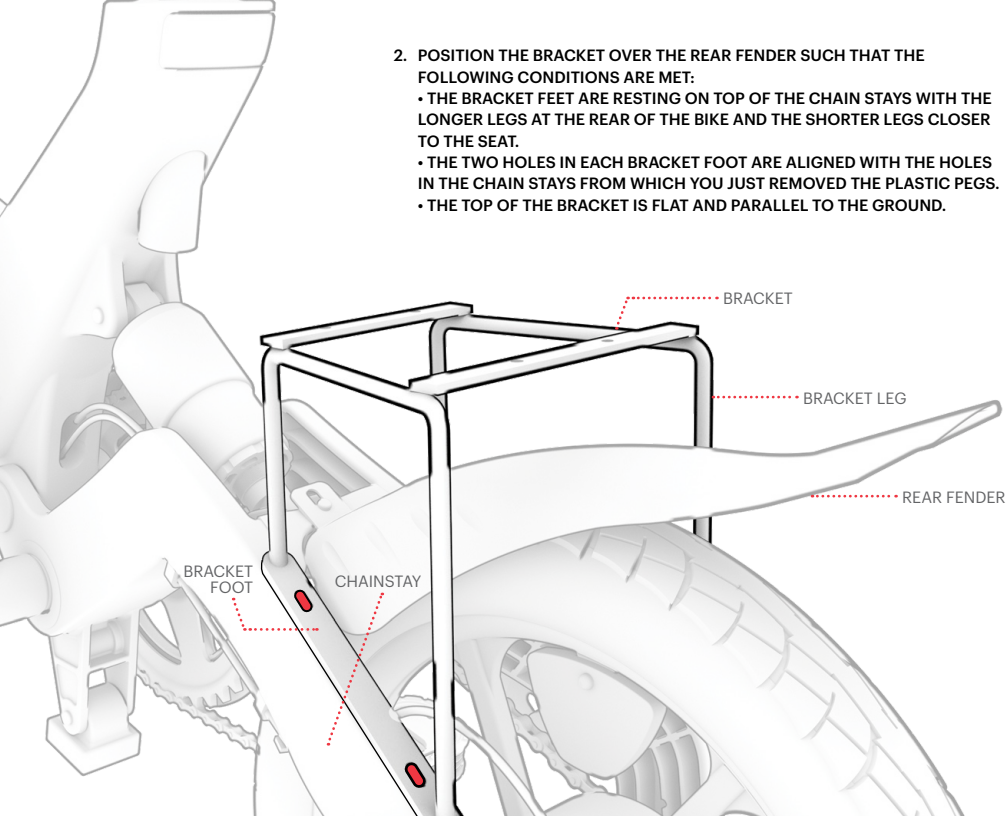

3. SLIDE 1 WASHER ONTO EACH OF 4 SCREWS.
4. INSERT BUT DO NOT FULLY TIGHTEN 1 SCREW WITH WASHER INTO EACH OF THE 4 SETS OF ALIGNED HOLES IN THE BRACKET FEET AND CHAIN STAYS BY TWISTING IT IN CLOCKWISE WITH THE ALLEN KEY. (2 ON EACH SIDE)
5. WORKING IN THE FOLLOWING ORDER, TIGHTEN EACH SCREW INTO THE BRACKET BY TWISTING IT CLOCKWISE WITH THE ALLEN KEY:
 - A) BACK LEFT SCREW
 - B) FRONT RIGHT SCREW
 - C) FRONT LEFT SCREW
 - D) BACK RIGHT SCREW
6. CHECK THAT THE BRACKET IS SECURE ON THE BIKE.

4 MM ALLEN KEY

WASHER
SCREW

BRACKET

CHAINSTAY

BRACKET
FOOT

5C

5A

5B

5D

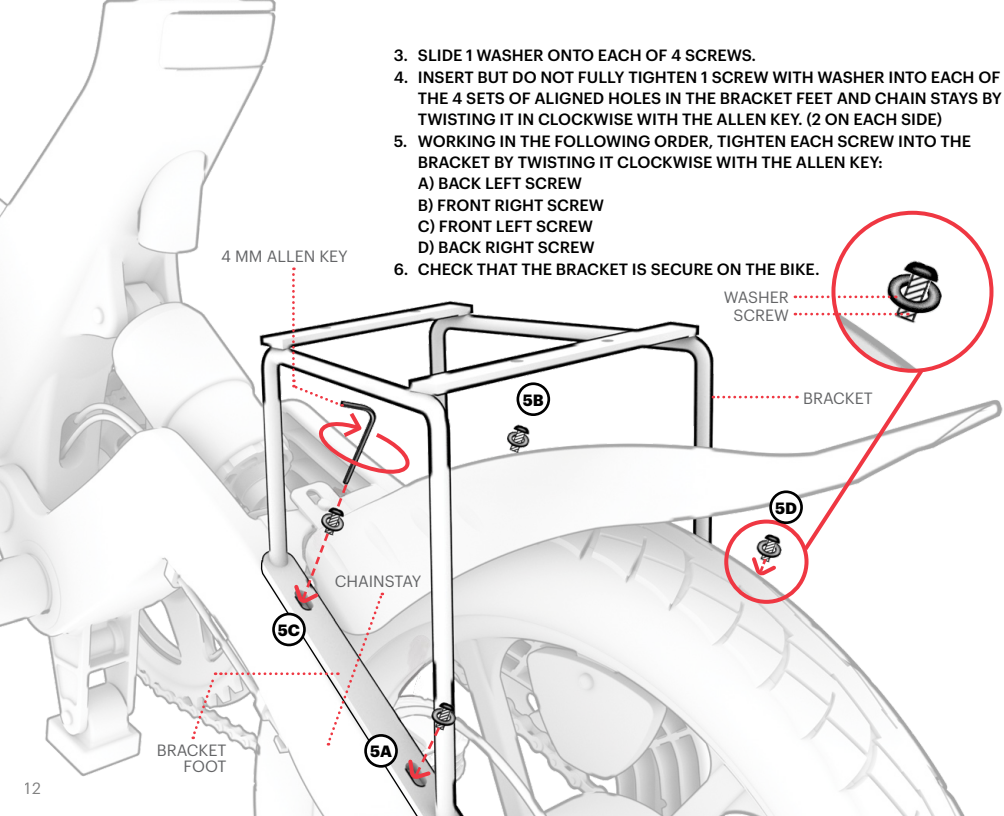

Attaching the Basket

1. POSITION THE BASKET ON TOP OF THE BRACKET SUCH THAT THE FOLLOWING CONDITIONS ARE MET:
 - THE BASKET OPENING IS FACING UP.
 - THE CURVED BACK WALL OF THE BASKET IS AT THE REAR OF THE BIKE.
 - THE 4 HOLES ON THE BOTTOM OF THE BASKET ALIGN WITH THE 4 HOLES ON THE TWO CROSSBARS ACROSS THE TOP OF THE BRACKET.

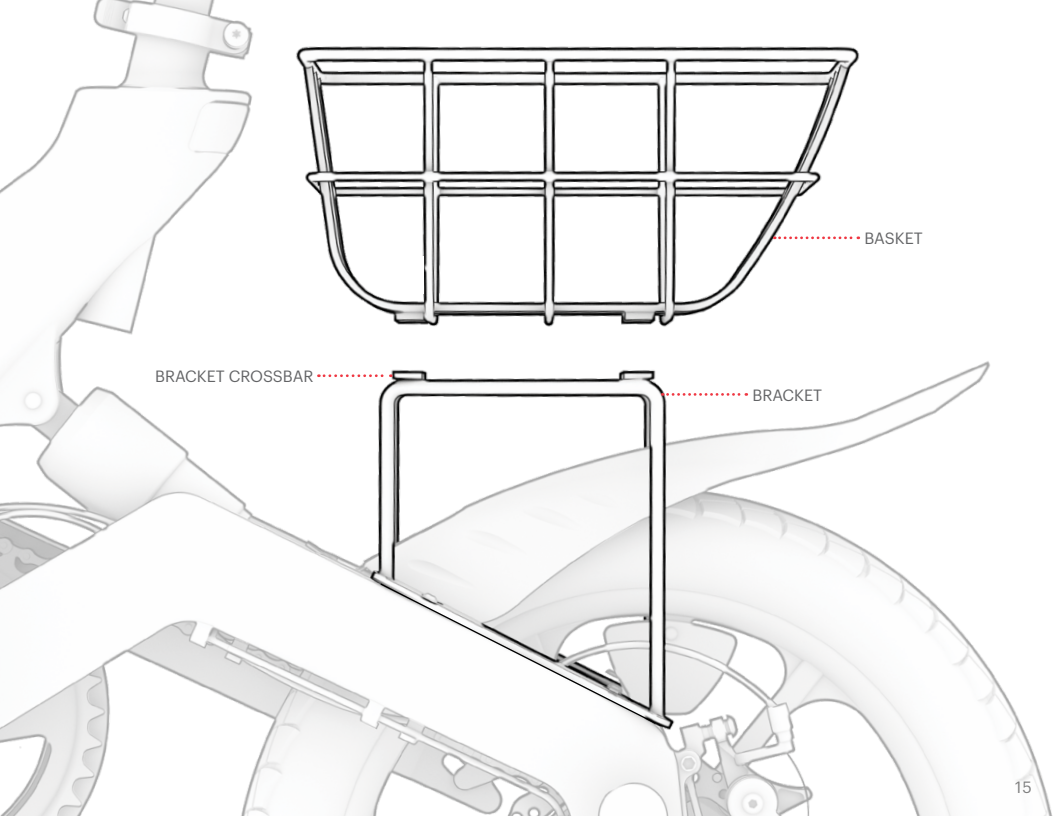

BASKET

BRACKET CROSSBAR

BRACKET

2. SLIDE 1 WASHER ONTO EACH OF 4 SCREWS.
3. INSERT BUT DO NOT FULLY TIGHTEN 1 SCREW WITH WASHER INTO EACH OF THE 4 SETS OF ALIGNED HOLES IN THE BOTTOM OF THE BASKET AND THE CROSSBARS AT THE TOP OF THE BRACKET BY TWISTING IT IN CLOCKWISE WITH THE ALLEN KEY. (2 ON EACH SIDE)
4. WORKING IN THE FOLLOWING ORDER, TIGHTEN EACH SCREW INTO THE BRACKET BY TWISTING IT CLOCKWISE WITH THE ALLEN KEY:
 - A) BACK LEFT SCREW
 - B) FRONT RIGHT SCREW
 - C) FRONT LEFT SCREW
 - D) BACK RIGHT SCREW

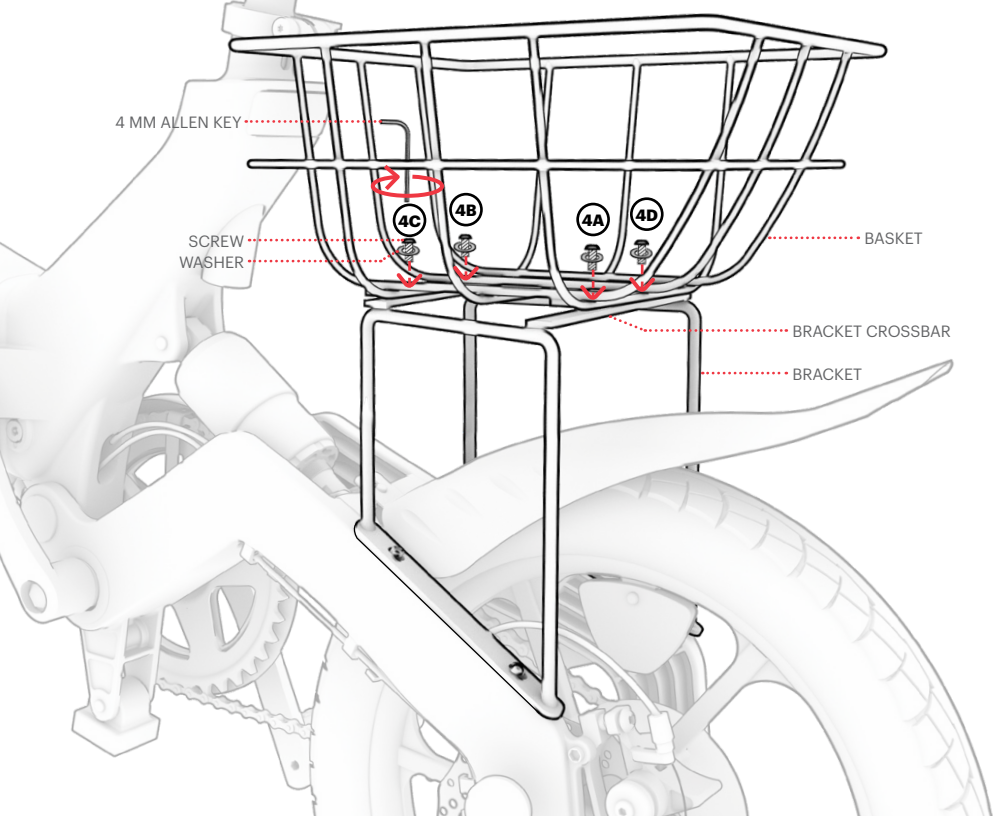

4 MM ALLEN KEY

SCREW
WASHER

4C

4B

4A

4D

BASKET

BRACKET CROSSBAR

BRACKET

5. CHECK THAT THE BASKET IS SECURE ON THE BRACKET.

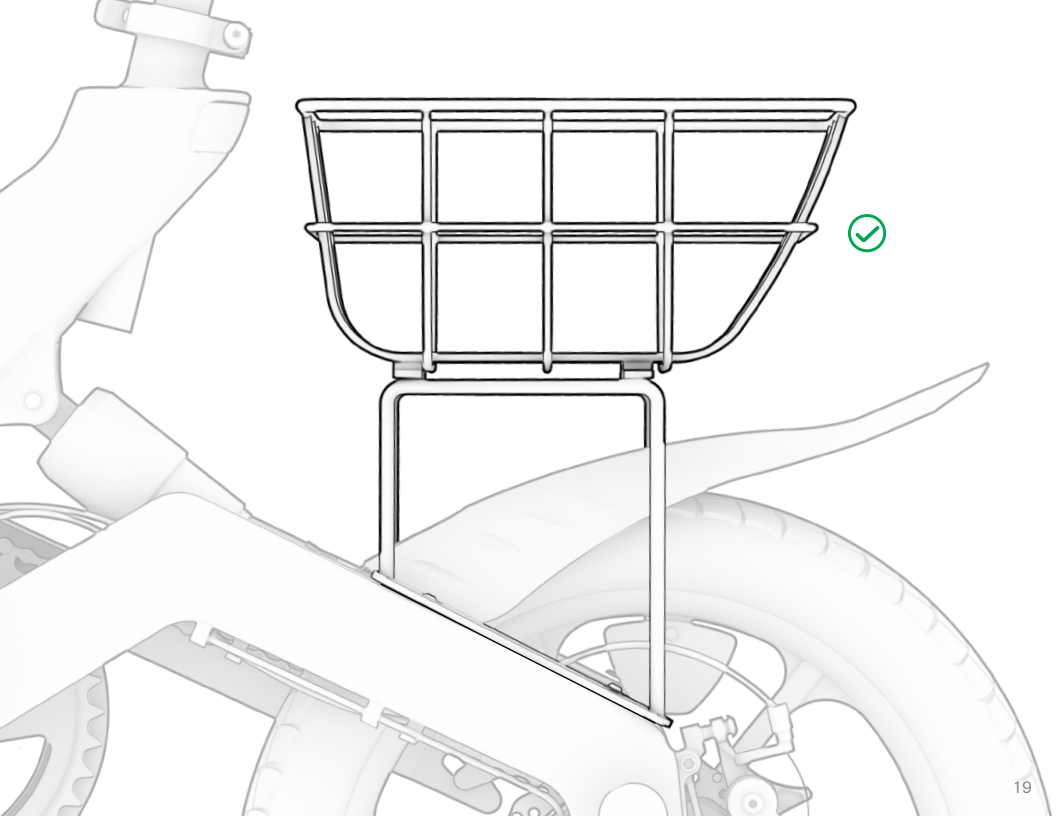

Using the Basket

FOR SAFETY AND SECURITY:

- LIMIT CARRYING CONTENTS TO 25 POUNDS.
- DO NOT OVERFLOW YOUR BASKET.
- ALWAYS SECURE CONTENTS WITH THE INCLUDED ELASTIC STRAP OR A BUNGEE CORD.

TO USE THE INCLUDED ELASTIC STRAP:

1. HOOK ONE SIDE OF THE STRAP ON THE UNDERSIDE OF THE BASKET.
2. LOOP THE STRAP OVER THE TOP OF THE BASKET.
3. HOOK THE OTHER END OF THE ELASTIC STRAP ONTO THE BASKET SUCH THAT IT IS TAUGHT AND SECURE OVER THE CONTENTS OF THE BASKET.

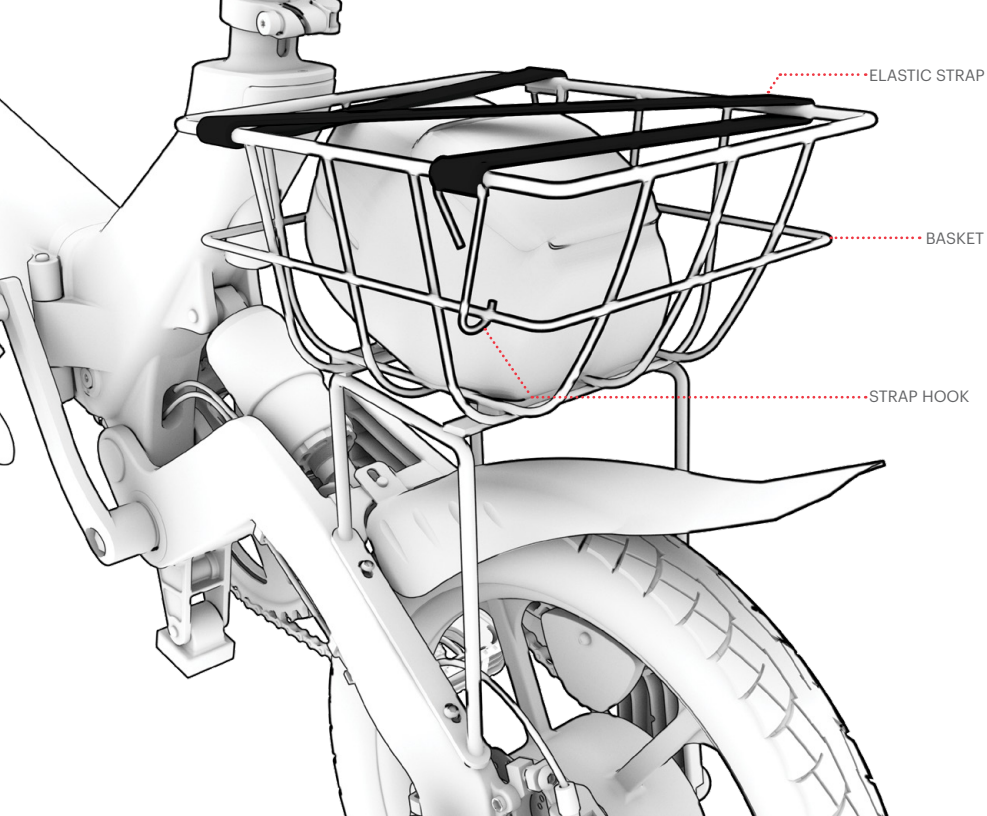

ELASTIC STRAP

BASKET

STRAP HOOK

Stay connected.

Be sure to follow **@ridejetson** on social media to learn about fantastic offers, giveaways, and all the latest Jetson news.



Loving your basket?

Then be sure to leave a review at ridejetson.com/reviews.
We can't wait to hear from you!

JETSON

#MakeMoves

Questions? Let us help.

ridejetson.com/support
ridejetson.com/chat

To exercise your product's warranty or inquire about warranty coverage, contact us directly.

US/CANADA: 1-888-976-9904
UK: +44 1355 241222

Manufactured in Hebei, China
Imported by Jetson Electric Bikes LLC.
P.O. Box 320149, 775 4th Ave #2,
Brooklyn, NY 11232

www.ridejetson.com



Made in China
Date Code: 06/2023
Document Edition: v1.1