

# ENGEL

portable fridge-freezers

**A LEGEND IN RELIABILITY**



SR48F  
Built-In

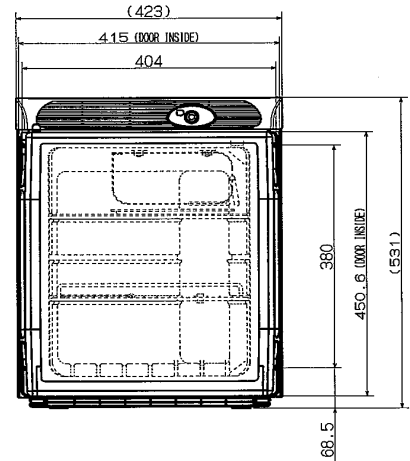
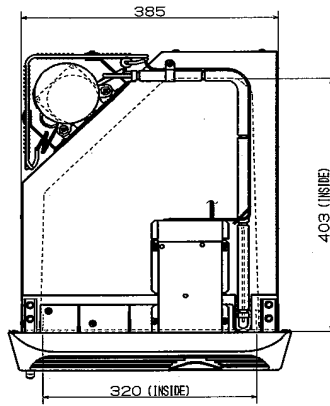
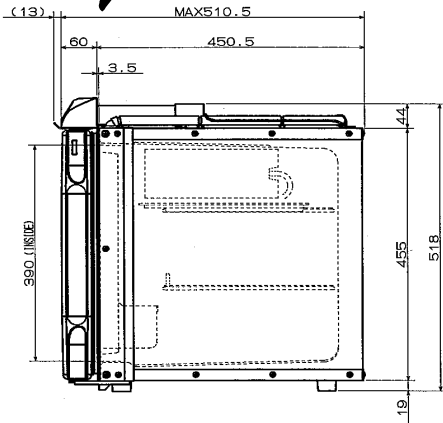

## TECHNICAL SPECIFICATION SHEET

### FEATURES:

100% CFC Free  
Thermostat Controlled  
Energy Efficient Sawafuji Swing Motor  
Low DC Current Draw: 12V 2.5 Amps  
Built-in Cabinet Design

Generator & Solar Panel Compatible  
Strong Construction  
Compact & Lightweight  
Noise Level: 32dB  
Polyurethane Insulation

Turbo Fan  
3 Year Manufacturers Warranty  
Reversible Door - LH / RH

### SPECIFICATIONS:

Storage Volume:	Litres	40 Litres
Overall Dimensions:	H x W x D	531mm x 423mm x 510mm
Installation Dimensions:	H x W x D	518mm x 385mm x 447mm
Materials:		
Cabinet:		
Outer Enclosure:	Galvanised Steel Plate	
Inner Case:	High Impact Polystyrene	
Insulation:	Polyurethane Foam (HFC-141b)	
Door:		
Door Panel:	Steel Plate	
Door Frame:	ABS & Polyvinyl Chloride (Gray)	
Door Liner:	Polypropylene	
Insulation:	Polyurethane Foam (HFC-141b)	
Attachments:	Ice Cube Tray x 1	
	Shelf x 1	
	Drainage Pan x 1	
	Door Pocket x 1	
Input Voltage:	AC	AC 185 ~ 264V, 50/60Hz
	DC	DC 10.5 ~ 32V
Rated Amperage:	AC	AC 0.35A
	DC	DC 12V 2.5A, 24V 1.3A
Compressor Rating:	AC 13 ~ 16V, 50Hz, 33W	
Refrigerant:	Tetrafluoroethane (R-134a)	
Weight:	19kg	

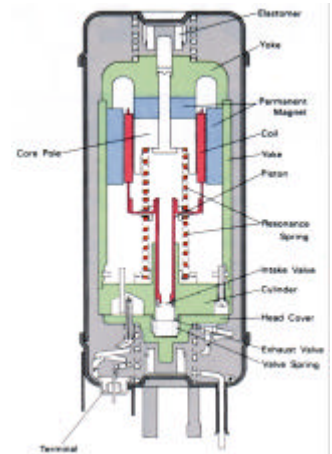

**Sawafuji Swing Motor**