

# SB-2350ART Swivel Tilt Extend TV Wall Mounts For 23-50" DISPLAYS

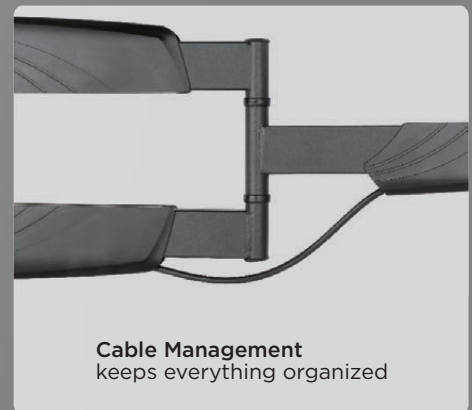

## WHY STARBURST?

Starburst Technologies (Starburst) TV-DISPLAY Wall Mounts offer an unbeatable combination of quality and cost effective price point. Each mount has been designed to work not only in the home, but also in a more demanding Commercial-hospitality environment.

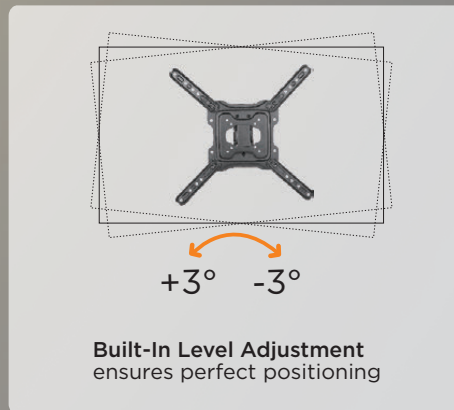
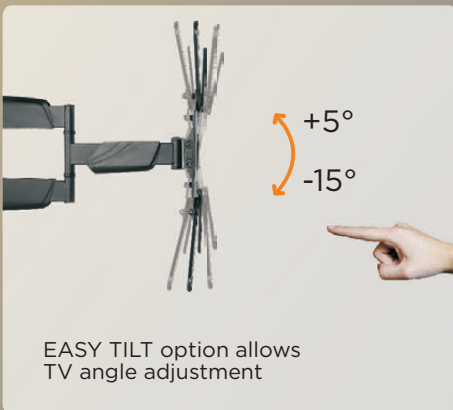

### CONTACT:

**Starburst Technologies®**  
a division of PDI Communications Inc.

6353 W Rogers Circle #6, Boca Raton, FL 33487  
TF: 800-242-1606  
Email: [sales@starburstmounts.com](mailto:sales@starburstmounts.com)  
Web: [www.starburstmounts.com](http://www.starburstmounts.com)

©2019 Starburst Technologies All rights reserved.

### STARBURST TECHNOLOGIES:

**Empowering Communication Networks  
since 1986**

Starburst Technologies (a division of PDI Communications Inc) is a full service design, engineering and manufacturing operation specializing in HD-TV components.

<https://starburstmounts.com/pages/why-starburst>  
<https://prezi.com/view/zDnpErebTKb2Vjvi9HMh/>



# SB-2350ART

## Swivel Tilt Extend

### TV Wall Mounts

#### For 23-50" DISPLAYS

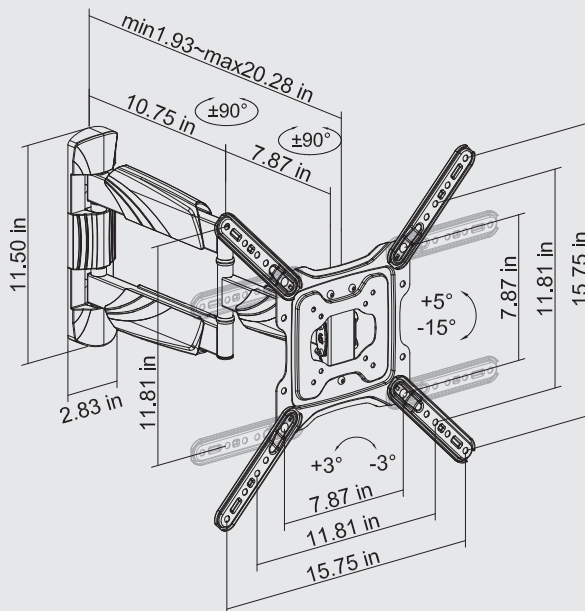

## Specifications

Screen Size	Weight Capacity	VESA	Profile to Wall	Swivel Range	Strength Tested
23"-50"	35 kg / 77 lbs	75x75 100x100 200x100 200x200 300x200 400x200 300x300 400x300 400x400	49-515mm/1.9-20.3"	+90° - -90°	Four Times

## Packing Information

Single Unit [inch]	Master Carton [inch]	QTY/Carton	Weights [lbs]	QTY 20' CONTAINER	QTY 40' CONTAINER
14.2"x10.6"x2.5"	14.8"x11.2"x15.9"	6.0 PCS	8 lbs single / 49 lbs carton	3738 PCS	7758 PCS

Units are packaged in a professional quality box that include all of the necessary installation hardware and easy to follow instructions.