

BAUMANN

shake n go!
personal
blender

Blend and puree in seconds

shake n go!
persönlicher
mixer

Mixen und Pürieren in Sekunden



BM-BL1019AGS

INSTRUCTIONS MANUAL/ GEBRAUCHSANWEISUNG

www.baumannliving.com

TABLE OF CONTENTS

IMPORTANT SAFEGUARDS	2
PARTS AND FEATURES	5
BEFORE FIRST USE	5
OPERATING THE BLENDER	6
CLEANING AND MAINTENANCE.....	10

IMPORTANT SAFEGUARDS

When using this appliance, basic safety precautions should always be followed, including the following:

1. Read all instructions.
2. Before using, check that the voltage power corresponds to the one shown on the appliance nameplate.
3. Do not let cord hang over edge of table or counter.
4. Do not place on or near a hot gas or electric burner, or in a heated oven.
5. Do not operate any appliance with a damage cord or plug or after the appliance malfunction or has been damaged in any manner. Return the appliance to the nearest authorized service facility for examination, repair or adjustment.
6. If the supply cord is damaged, it must be replaced by the manufacturer or its service agent or a similarly qualified person in order to avoid a hazard .
7. Close supervision is necessary when any appliance is used by or near children.
8. Avoid contact with moving parts.
9. Blades are sharp, so handle carefully.
10. The use of attachments, including jar and jar lid, not recommended or sold by manufacturer may cause fire, electric shock or injury.
11. The appliance cannot be used for blending hard and dry substance; otherwise, the blade could be blunted.

12. Unplug from outlet when not in use, before putting on or taking off parts, and before cleaning.
13. To protect against risk of electrical shock do not put motor unit or power cord in water or other liquid.
14. Do not use outdoors.
15. Keep hands and utensils out of container while blending to reduce the risk of severe injury to persons or damage to the blender. A scraper may be used but must be used only when the blender is not running.
16. To reduce the risk of injury, never place cutter-assembly blades on base without jar properly attached.
17. Always operate blender with cover in place.
18. The appliance can be used by children aged from 8 years and above and persons with reduced physical, sensory or mental capabilities or lack of experience and knowledge if they have been given supervision or instruction concerning use of the appliance in a safe way and understand the hazards involved. Children shall not play with the appliance. Cleaning and user maintenance shall not be made by children unless they are older than 8 and supervised.
19. Keep the appliance and its cord out of reach of children less than 8 years.
20. **Warning:** never use hot liquids or run the appliance empty.
21. Be care of potential injury from misuse.
22. Care shall be taken when handling the sharp cutting blades, emptying the bowl and during cleaning.

23. Be careful if hot liquid is poured into the blender as it can be ejected out of the appliance due to a sudden steaming.
24. Switch off the appliance and disconnect from supply before changing accessories or approaching parts that move in use.
25. This appliance is intended to be used in household and similar applications such as:
 - a. Staff kitchen areas in shops, offices and other working environments;
 - b. Farm houses;
 - c. By clients in hotels, motels and other residential type environments;
 - d. Bed and breakfast type environments.

SAVE THESE INSTRUCTIONS

FOR HOUSEHOLD USE ONLY

PARTS AND FEATURES

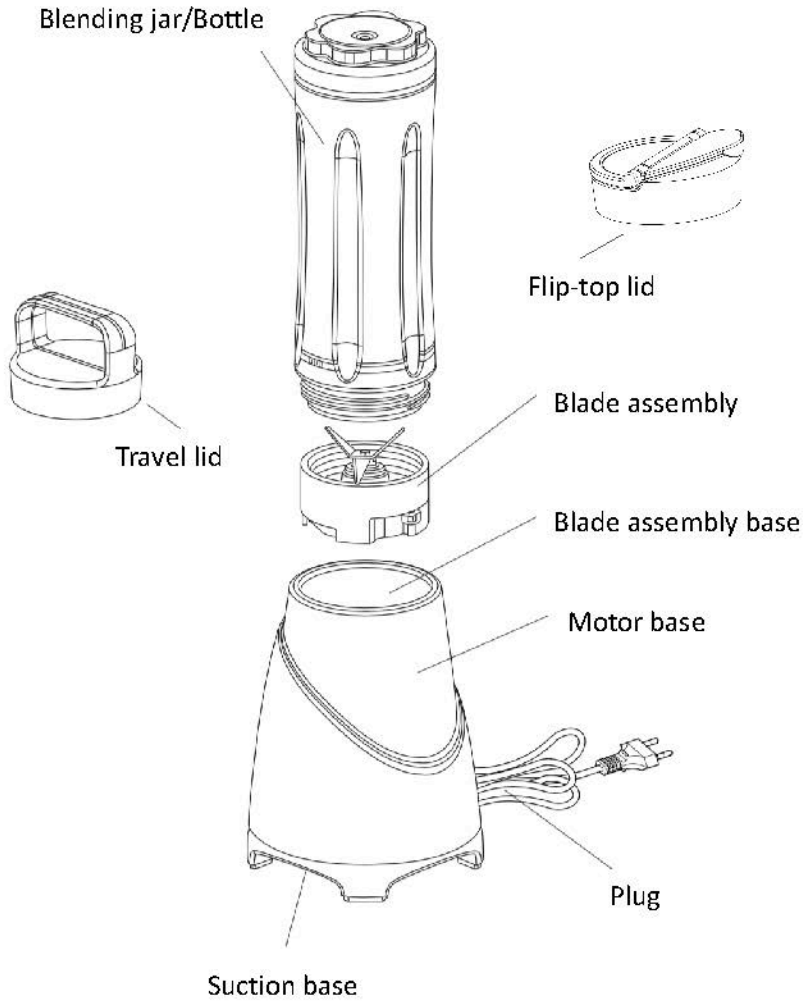

BEFORE FIRST USE

1. After unpacking, make sure the appliance is intact, complete with all its parts as shown in the illustrative guide and with no sign of damage due to transportation.
2. Wash the bottles, blade assembly and lids in warm water with dishwashing detergent.
3. Dry thoroughly with a soft cloth.

Warning: *The blade is sharp. Handle carefully.*

INFORMATION CONCERNING CONTACT WITH FOOD

The following table indicates:

- the parts of the appliance designed to come into contact with food
- the types of food which may be used in this appliance
- the maximum period of time for which food may remain in contact with the parts of the appliance intended for contact with food
- the maximum permissible temperature of food used in the appliance.

Part	Permitted food	Maximum time allowed for contact with food	Maximum food temperature allowed
Blade assembly	All	5 minutes	Less than 40°C
Blending jar Bottle lid	All	24 hours	Less than 40°C

OPERATING THE BLENDER

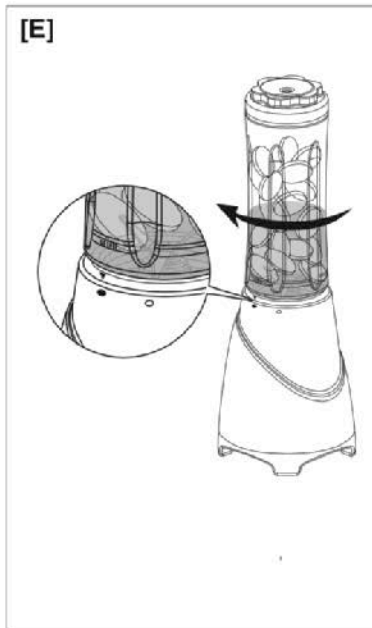
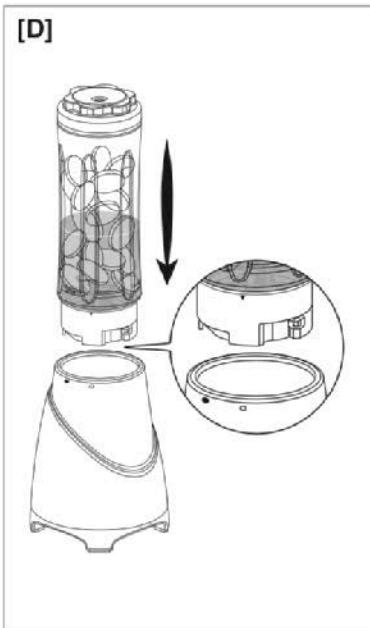
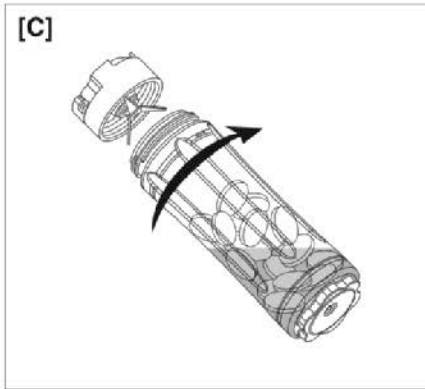

1. Place the motor base on a flat surface. Make sure the power outlet is unplugged.
2. Place the blending jar on a flat surface with the open end facing up. Fill the jar with your favorite ingredients. Peel, pit and remove seeds from fruit and vegetables. Preferably, you should use soft, fresh fruit or vegetables. Cut fruits and vegetables into pieces that are approx. 0.5-0.75 inches in size. Put in solid ingredients first, followed by liquid ingredients. **[Fig B]**

Note: *Only fill the bottle to approximately 2/5 of its total capacity with solid ingredients and to approximately 3/5 of its total capacity with liquid ingredients. Increase the quantity of liquid in the bottle if the food is not blended adequately.*

3. Screw the jar completely onto the blade assembly by turning clockwise. **[Fig C]**
4. Shake the jar to mix the ingredients.
5. Fit the jar onto the blade assembly base, aligning the arrow on the blade assembly (▼) with the arrow (▼) on the motor motor base. **[Fig D and E]**
6. Twist the jar in the direction indicated by the arrow ↻ (clockwise) until the contents have been blended to the required consistency.

7. To stop blending, twist the jar counter-clockwise to return it to its initial position.
8. Twist the jar counter-clockwise to remove it from the motor base.
9. Turn the jar over and unscrew the blade assembly, turning counter-clockwise.
10. Pour the contents of the jar into a drinking cup or screw the drinking lid onto the jar. Make sure that the lid is tightly closed before using the bottle to transport the contents or store the contents in the refrigerator.

Important Reminders:

- Wash the parts that come in contact with food before using them.
- The appliance can be operated without interruption for a maximum of 1 minute, after which it should be allowed to cool down to room temperature.
- Never use boiling liquids or run the appliance empty.
- Never place the blending jar in a microwave oven.
- Switch the appliance off before removing the jar.
- When blending ice/frozen food, start with brief pulses then blend continuously.
- Do not use the appliance to blend or grind dry ingredients (e.g. spices and nuts)

CLEANING AND MAINTENANCE

1. Pour a little warm soapy water into the jar and turn on the blender for a few seconds. Remove the jar from the base unit and rinse all parts under running water. You may also clean manually clean the jar, lid and blade assembly with a small amount of detergent and warm water.
2. Wipe the outer surface of the motor base with a soft damp cloth.

Warning: *Do not use abrasive cleaners. Never immerse the motor base in water for cleaning.*

Note: *All parts except for the motor base are dishwasher-safe.*

3. Dry all parts completely.