



Because your life is on the line!

100 North Thirteenth Street • Franklin, PA 16323 • Toll Free: 877.228.9327 • 814.437.1808

fax: 814.437.2544 • fcp@velocity.net • www.frenchcreekproduction.com

Proudly Made in the U.S.A.

User Instructions – FCPQ200 Quad Pod System



This document serves as the Manufacturer's Instructions, and is to be used as part of an employee training program for the system, as required by OSHA.

ATTENTION: The user **MUST** be trained before using this product. Use this manual as part of a user safety training program that is appropriate for the user's occupation. These instructions must be provided to users before use of the product and retained for ready reference by the user. The user must read, understand (or have explained), and follow all instructions, labels, markings and warnings supplied with this product and with those products intended for use in association with it. **FAILURE TO DO SO MAY RESULT IN SERIOUS INJURY OR DEATH.**

*****Warning:** Read, understand, and follow all instructions. Failure to do so may result in serious injury or death. Do not use unless properly trained. It is the employer's responsibility to ensure that all users are properly trained in the proper use, inspection, and maintenance of fall protection equipment.

General Requirements

- Users shall be provided with all instructions and warnings. These warnings and instructions must be read and understood prior to using the equipment.
- This product is designed for personal fall protection. Never use fall protection equipment for purposes other than which it was designed and intended for.
- This device must only be used by trained personnel.
- Users must be physically and mentally fit, in good health, and must not have a medical history of conditions that could be aggravated by a fall. Pregnant women and minors must not use this product.
- Users must reference ANSI Z359.1 and all applicable regulatory standards pertaining to occupational safety.
- All equipment must be visually inspected prior to each use. A more thorough inspection procedure is recommended by a competent individual on a regular basis (6 month intervals recommended). Refer to the inspection criteria for more details.
- A competent person must ensure system compatibility to minimize the potential for accidental disengagement.
- Equipment must not be altered in any way. Repairs or modifications must be performed only by the equipment manufacturer or persons authorized in writing by the manufacturer.
- Any products exhibiting deformities, unusual wear, deterioration, or not passing inspection must be immediately removed from service.
- Any products subjected to fall arresting forces must be removed from service.
- Fall arrest systems must be rigged to limit the free fall distance to 6' or less and ensure that no lower level is struck.
- Fall arrest systems, when stopping a fall, must limit the maximum arresting force to 1800 lbs. or less. Forces experienced during a fall as well as prolonged suspension may cause bodily injury. In order to minimize this risk of injury, the user shall have a rescue plan and the means at hand to implement it when using this equipment.
- Always check for obstructions below the work area to make sure the potential fall path is clear. Remember that shock-absorbers can elongate up to 3 ½'.
- Environmental hazards must be considered when selecting fall protection equipment. Equipment must not be exposed to chemicals which may have a damaging effect. All synthetic materials must be protected from slag, hot sparks, open flames, or other heat sources.
- This product should not be used around moving machinery, electrical hazards, sharp edges, and abrasive surfaces.
- The maximum working load is 350 lbs. unless otherwise labeled.

The FCP Quadpod Model FCPQ200 (Figures 1 and 2) is a portable, lightweight, high-strength anchor point for FCP confined space and rescue equipment and is part of a system which includes fall arrest and recovery equipment as well as a Personnel or Material Winch. The major parts of the FCP Quadpod are illustrated in Figures 1, 2, 3 and described below.

The FCP Quadpod consists of two parts -a boom and a base (Figure 3).

1. Boom (Figure 1). The boom is made of steel, and has on one end a cylinder (1) for attaching to the base. The opposite end of the boom has two pulleys (2) with a security pin (3) for the fall protection and rescue equipment. There are two brackets (4 and 5) for the attachment of FCP types of fall protection and recovery systems. There exist two sets: Three-Way Fall Protection and Recovery Unit with a Work Winch (Figure 1), and Three-Way Rescue and Recovery Unit with Personnel Winch (Figure 2). In Figure 3 bracket (4) is for the attachment of a Three-Way fall protection and recovery unit and bracket (5) is for the attachment of a Work Winch. In Figures 2 and 3 bracket (4) is for the attachment of a 3 Way Reescue and Recovery Unit and bracket (5) is for attachment of a Personnel Winch. When the boom is attached to the base by the cylinder, the boom can be rotated by an angle of 360 degrees. The screw handle (6) is designed to fix or release the boom on the base in the necessary position.
2. Base. The base is a construction with four points of support, each of which is a triangular truss consisting of square aluminum tubes. One tube of each triangle is connected to the upper aluminum head (7) while a second tube is connected to a moving collar (8). The two tubes are connected to each other in a hinge-like manner. The central post (9) is a common support for all four triangular trusses. The upper end of the central post is a cylindrical shaft (Figure 3, Position 10) onto which the cylinder (1) of the boom is attached. To level the base on a surface, each point of support ends in an adjustable threaded foot (11).

Technical Specifications

Refer to accompanying figure for illustration of dimensions and specifications listed below.

• Interior headroom height	91
• Interior distance between points of support of the base	54
• Recommended hole diameter	36
• Load (raise or lower a person)	350 600
• Overall height when set up with legs at maximum extension	94
• Storage height of base	60
• Storage diameter of base	24
• Weight (boom) (base)	42 79
• Outreach from center	26
• Distance from surface to top of the upper aluminum head	38
• Angle of rotation of the boom	3600
• Tested static load	5400

Sizes – Inches

Loads – Lbs.

INSTALLATION PROCEDURES

All individuals who may use or be required to use the Quadpod MUST be instructed on how to use it correctly. They MUST read, understand, and follow all instructions and warnings stated on the Quadpod or contained in or attached to the Quadpod. A review of the proper procedure should be made before each use.

Assembly

Before using, make sure that the Quadpod meets the application requirements as described in the technical specifications, that is:

- The center of the opening corresponds to the center of the Quadpod
- The diameter of the opening is within the range specified in the technical specifications.
- The interior height of the Quadpod is chosen correctly.

Before assembling, inspect the vicinity around the work area for debris and other material that could cause injuries or interfere with the operation of the system. Be sure that the Quadpod is positioned on a hard, stable surface before use. Also, caution should be taken to ensure that all equipment is clear of any electrical hazard and that proper ventilation has been provided in the work area before the worker's descent into the space. When using this equipment, a second worker besides the one attached to the unit must be present as a guide or supervisor.

Recommended Assembly:

1. Do not open the cover of the confined space. If it is open, close the space using the cover.
2. Place the contracted base on the floor near the confined space.
3. Remove the pin (12) from the collar (8) and extend all four points of support to full length so that the center of the Quadpod is 26" away from the center of the confined space opening.
4. If necessary, adjust all four points of support to the proper horizontal level by adjusting the feet (11).
5. Install the boom on the shaft (10) of the base using the cylinder (1) of the boom.
6. Install the fall protection and recovery units (13) (Three-Way 2005 or Two-Way 2003 or equivalent FCP equipment) on the bracket (4) by using two lock pins.
7. Install the FCP Personnel Winch or FCP Work Winch or alternative equivalent equipment on the bracket (5) by using lock pins with hitch pins.
8. Pull out the cable from each unit, pass it through the upper pulleys (2), and fix it using the security pin (3).
9. Rotate the boom into working position so that the cable is vertically aligned with the center of the confined space opening and secure it with screw handle (6).
10. Open the cover of the confined space and fulfill all OSHA requirements before entering the confined space. (Check for gas, ventilation, and all other requirements indicated by OSHA for your particular application. The responsibility for proper use of the equipment is assumed by the company that uses it).
11. Connect the ends of the cables of the fall protection and recovery systems to the D-ring of the worker's harness. When using fall protection and rescue equipment, you must refer to the section of this manual concerning the use of such equipment.

INSPECTION PROCEDURES

WARNING: NEVER use the Quadpod without prior inspection.

1. Inspect the work area for debris and other material that could cause injuries or interfere with the operation of the unit. Be sure that the Quadpod is positioned on stable, hard surface before setting it up.
2. A competent person, for example a safety director, must schedule regular safety inspection based on amount for use and working conditions.
3. Remove from service immediately if any function, component or part does not pass this inspection, or whenever subjected to a severe free fall.
4. Never use the Quadpod in conjunction with safety devices not manufactured by FrenchCreek Production, Inc. or designed specifically for use with this Quadpod without the express prior permission of FrenchCreek Production, Inc.

Disassembly

1. Close the cover of the confined space.
2. Remove all FCP fall protection equipment from the Quadpod.
3. Release the handle (6) and detach the boom from the base.
4. Remove the pin (12) that holds the base in extended position and contract the base into storage position. Replace the pin (12) to fix the base in this position.
5. Transport the Quadpod to the next location or to storage.

Storage and Maintenance Log for Quadpod

A written log of all servicing and inspection dates for this device should be maintained by the company safety officer.

1. Always dismount the devices from the Quadpod. Store the Quadpod in transport mode (Figure 5) in an area free of corrosive elements and excessive heat.
2. Do NOT store this unit in environments corrosive to aluminum, avoid use in areas that may contain high concentrations ammonia. Avoid use with acids, alkaloids, or other caustic chemicals especially at elevated temperatures.
3. Clean exterior of case with water and mild detergent, rinse, and thoroughly air dry. Do NOT use harsh chemicals. Clean labels as required.
4. Never attempt to repair or modify any part or components. Repair MUST be performed by FrenchCreek Production, Inc.

WARNINGS

Employer: Instruct employee as to proper use and warnings before use of this equipment.

Designed only to raise or lower one worker of not more than 350 lb. or equipment of not more than 600 lb.

Read, understand, and follow all instructions and warnings provided with this unit.

For use by properly trained personnel only.

Always use the buddy system (two workers) while operating this unit.
Insure that the Quadpod is positioned on a hard, stable surface before use.

To insure compatibility, use only FCP components.

Inspect before use. If any part or component shows damage or excessive wear, or does not function properly, the entire unit should be removed from service.

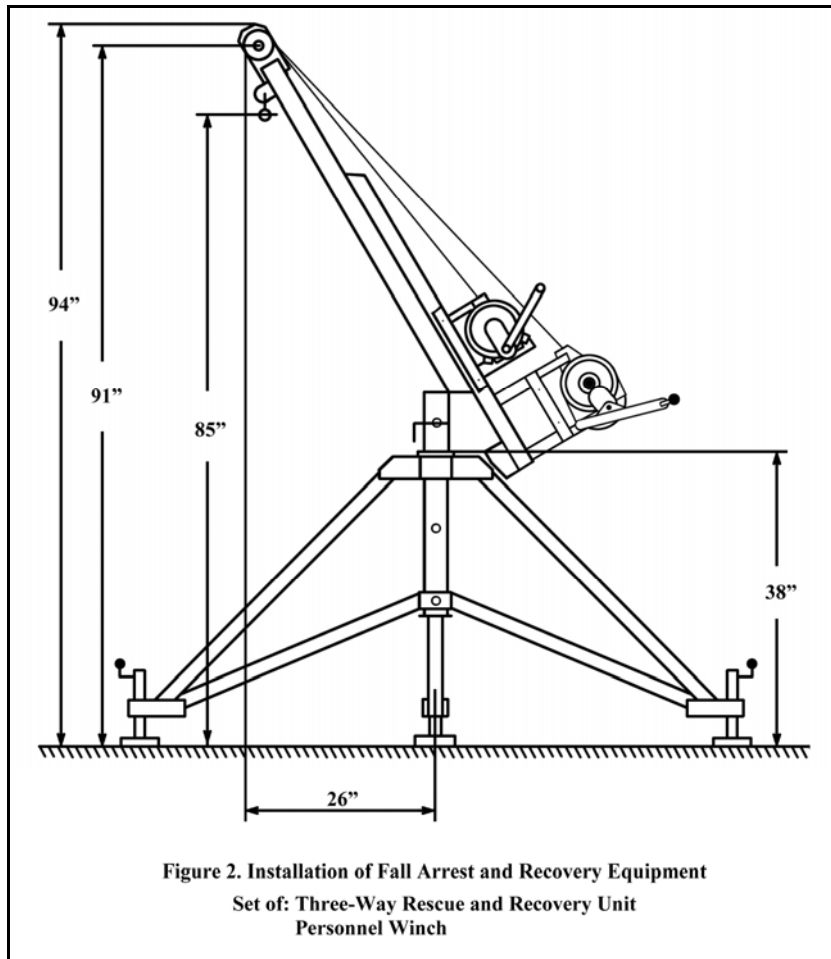
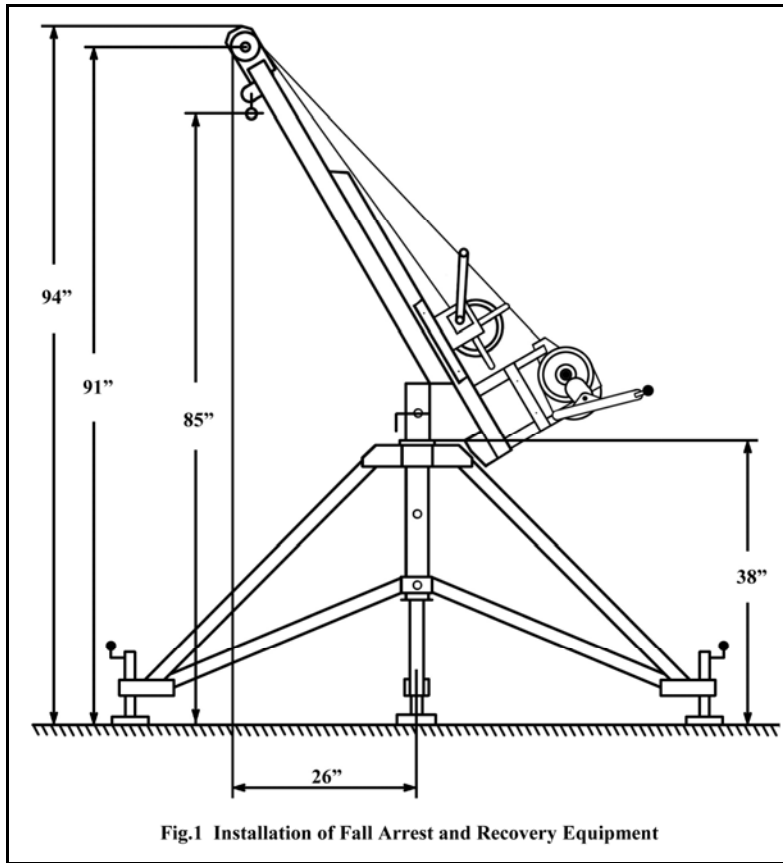

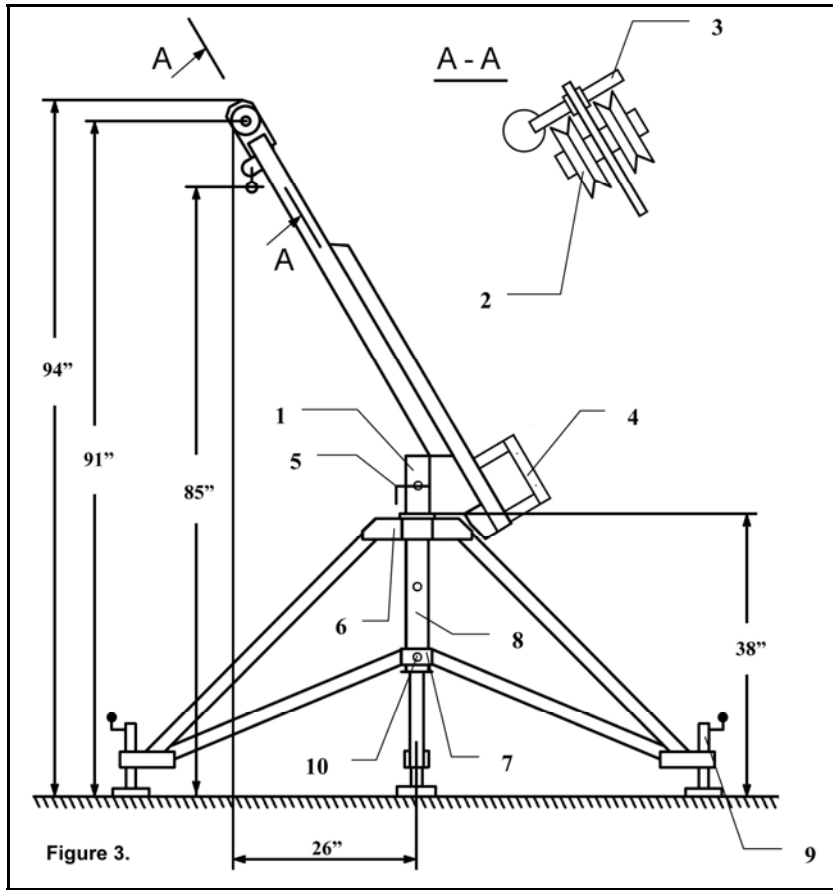

Figure 3.

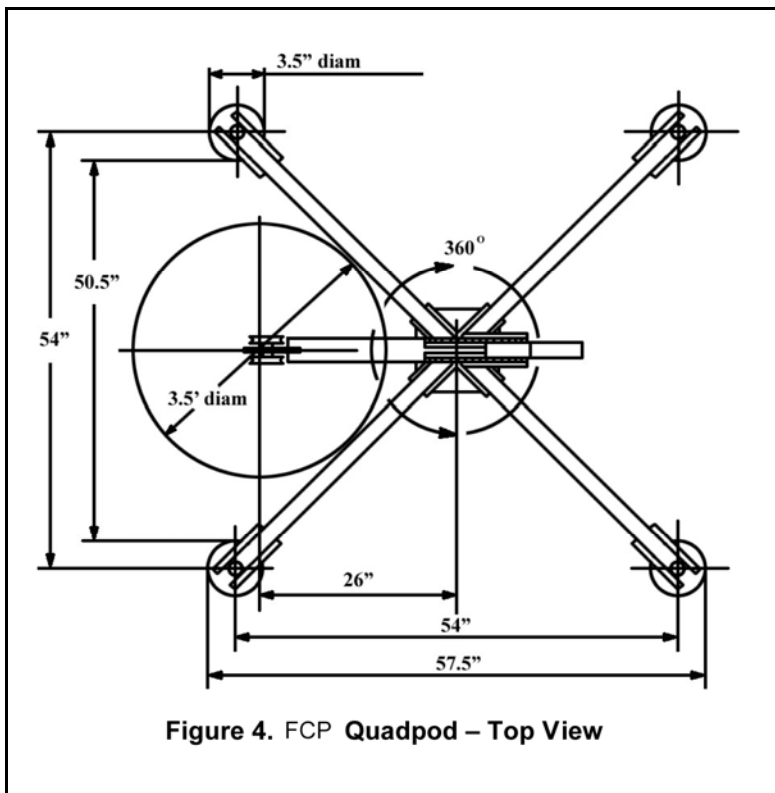

Figure 4. FCP Quadpod – Top View

