

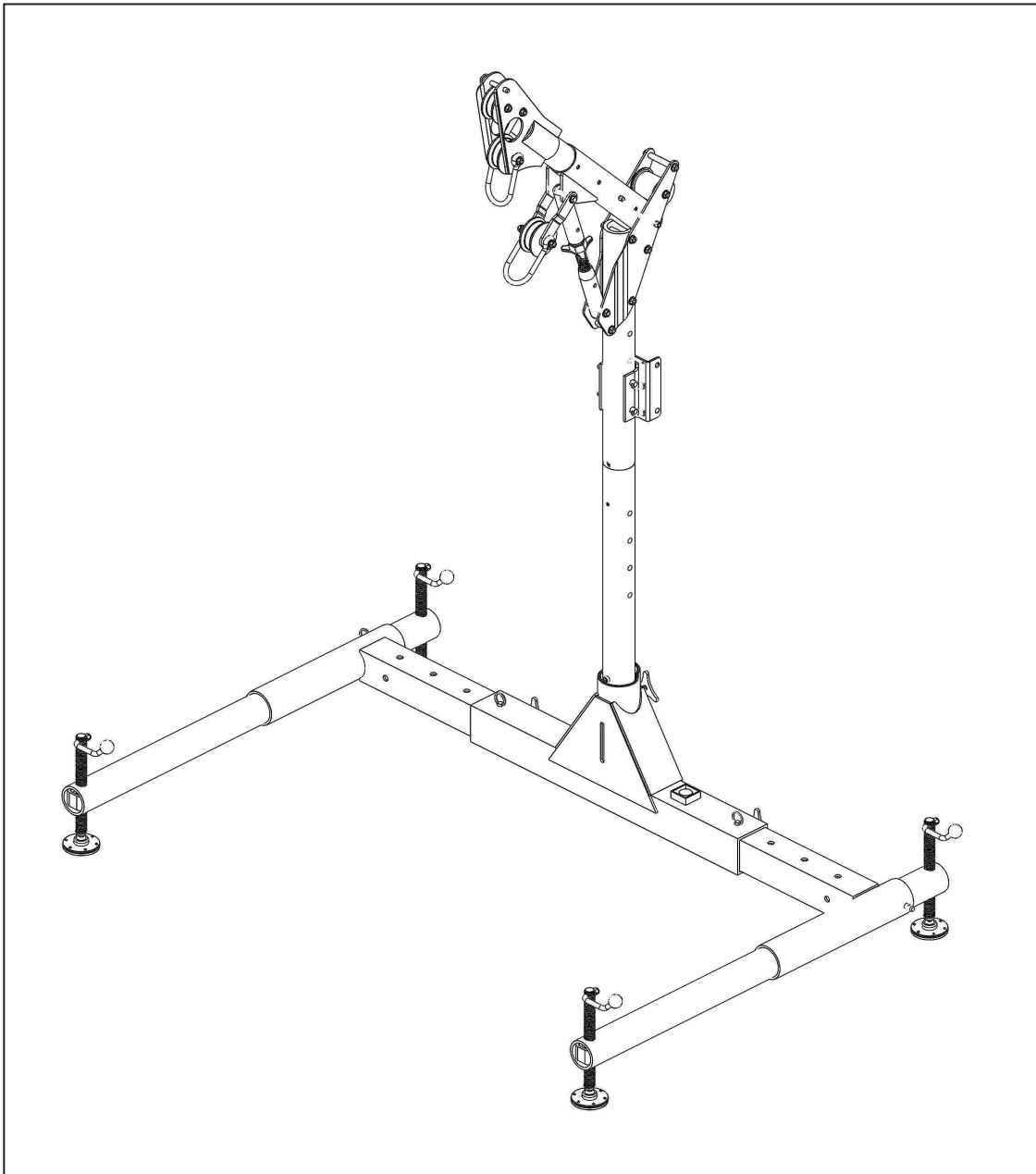

FALLTECH[®]
Fall Protection, Precision Engineered.

5-Piece Confined Space Davit System

User Instruction Manual



This manual is intended to meet the Manufacturer's Instructions as required by the American National Standards Institute (ANSI) Z359 and should be used as part of an employee training program as required by the Occupational Safety and Health Administration (OSHA).

Table of Contents

1.0	Warnings and Important Information	3
2.0	Application	4
3.0	System Requirements	5
4.0	Installation and Use	5
5.0	Maintenance, Service and Storage	12
6.0	Inspection	12
7.0	Labels	13
8.0	Definitions	15
	Appendix A	17

For the purposes of this manual, the Confined Space 5-Piece Davit System may be referred to as the Davit, the system or the FallTech Confined Space Davit.

Throughout this manual, ANSI Z359.0-2012 fall protection words, phrases and terms are used. These terms are all formally defined in Section 8.0 of this manual.

1.0 Warnings and Important Information

WARNING

- Avoid moving machinery, thermal, electrical and/or chemical hazards as contact may cause serious injury or death.
- Avoid swing falls.
- Follow the weight restrictions and recommendations in this manual.
- Remove from service any equipment subjected to fall arrest forces.
- Remove from service any equipment that fails inspection.
- Do not alter or intentionally misuse this equipment.
- Consult FallTech when using this equipment in combination with components or subsystems other than those described in this manual.
- Do not connect rebar hooks, large carabiners, or large snap hooks to the FBH dorsal D-rings as this may cause a roll-out condition and/or unintentional disengagement.
- Avoid sharp and/or abrasive surfaces and edges.
- Use caution when performing arc welding. Arc flash from arc welding operations, including accidental arcs from electrical equipment, can damage equipment and are potentially fatal.
- Examine the work area. Be aware of the surroundings and workplace hazards that may impact safety, security, and the functioning of fall arrest systems and components.
- Hazards may include but not be limited to cable or debris tripping hazards, equipment failures, personnel mistakes, moving equipment such as carts, barrows, fork lifts, cranes, or dollies. Do not allow materials, tools or equipment in transit to contact any part of the fall arrest system.
- Do not work under suspended loads.

IMPORTANT

This product is part of a personal fall arrest, restraint, work positioning, suspension, or rescue system. A Personal Fall Arrest System (PFAS) is typically composed of an anchorage and a Full Body Harness (FBH), with a connecting device, i.e., a Shock Absorbing Lanyard (SAL), or a Self-Retracting Device (SRD), attached to the dorsal D-ring of the FBH.

These instructions must be provided to the worker using this equipment. The worker must read and understand the manufacturer's instructions for each component or part of the complete system. Manufacturer's instructions must be followed for proper use, care, and maintenance of this product. These instructions must be retained and be kept available for the worker's reference at all times. Alterations or misuse of this product, or failure to follow instructions, may result in serious injury or death.

A Fall Protection Plan must be on file and available for review by all workers. It is the responsibility of the worker and the purchaser of this equipment to assure that users of this equipment are properly trained in its use, maintenance, and storage. Training must be repeated at regular intervals. Training must not subject the trainee to fall hazards.

Consult a doctor if there is reason to doubt your fitness to safely absorb the shock of a fall event. Age and fitness seriously affect a worker's ability to withstand falls. Pregnant women or minors must not use this equipment.

ANSI limits the weight of fall protection equipment users to a maximum of 310 lbs. Products in this manual may have a rated capacity exceeding ANSI capacity limits. Heavy users experience more risk of serious injury or death due to falls because of increased fall arrest forces placed on the user's body. In addition, the onset of suspension trauma after a fall even may be accelerated for heavy users.

The user of the equipment discussed in this manual must read and understand the entire manual before beginning work.

NOTE: For more information consult the ANSI Z359 body of standards.

2.0 Application

- 2.1 Purpose:** The FallTech Confined Space Davit is designed to work as part of a system to raise or lower a person or material to work in a confined space for entry, retrieval, fall arrest applications and material handling. The FallTech Confined Space Davit is a modular design and allows multiple configurations with optional bases and mounting methods.
- 2.2 Application Limits:** The FallTech Confined Space Davit is a dynamic anchorage system that will vary in its performance depending upon offset the user configures. Care should be taken to understand the capacity of the system and anchorage strength requirements.
- 2.3 System Capacity:** The maximum capacity of the FallTech Confined Space Davit is one worker for confined space entry and egress, with the worker weighing no more than 310lbs (140kg) including clothing, tools, etc. For rescue applications, the FallTech Confined Space Davit has a maximum capacity of two workers with each worker weighing no more than 310lbs including tools, clothing, tools, etc. To determine which confined space davit configurations are suitable for rescue, please see the tables in Figure 1 and 2.
- 2.4 Davit Anchorage Strength:** When using the FallTech Confined Space Davit with the 3-Piece Portable Base, the mounting surface must support 5000lbs. When using the FallTech Confined Space Davit with any other base, please refer to the user instruction manual for the specific base.

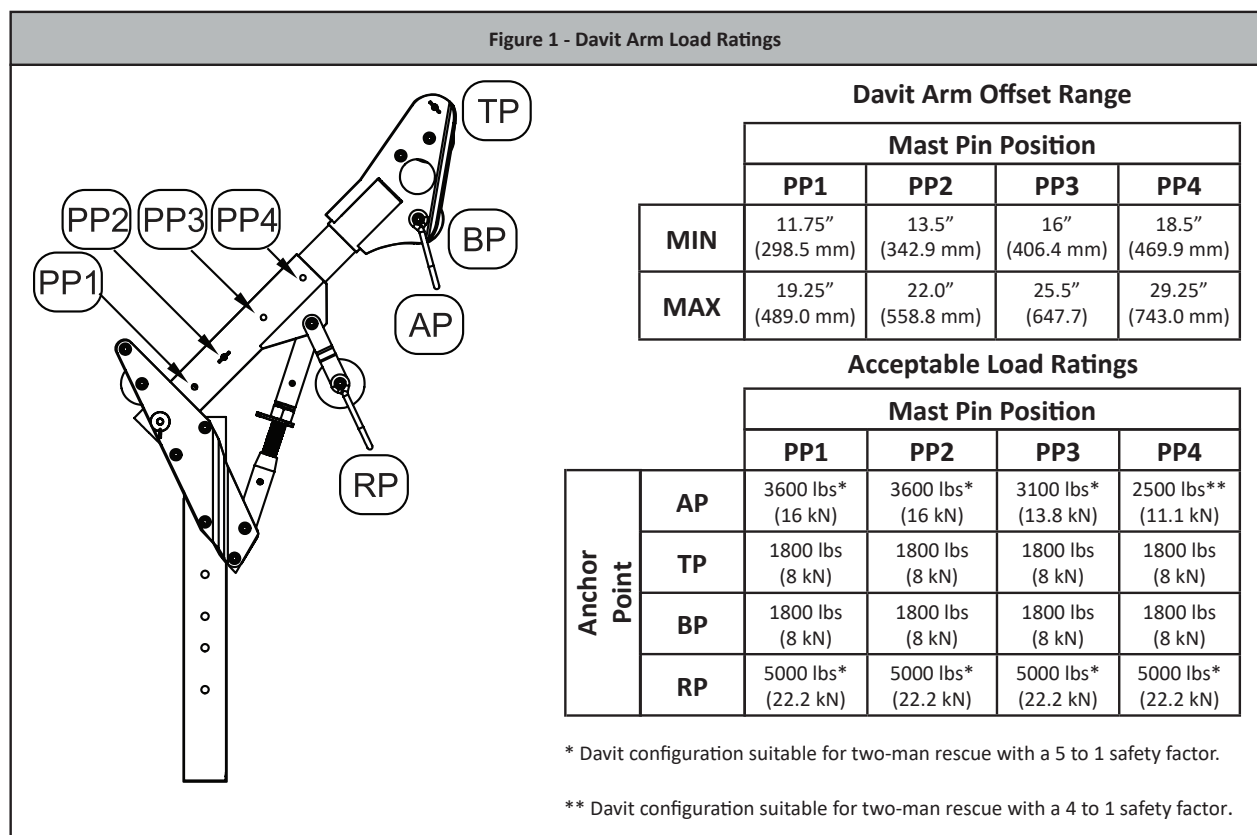
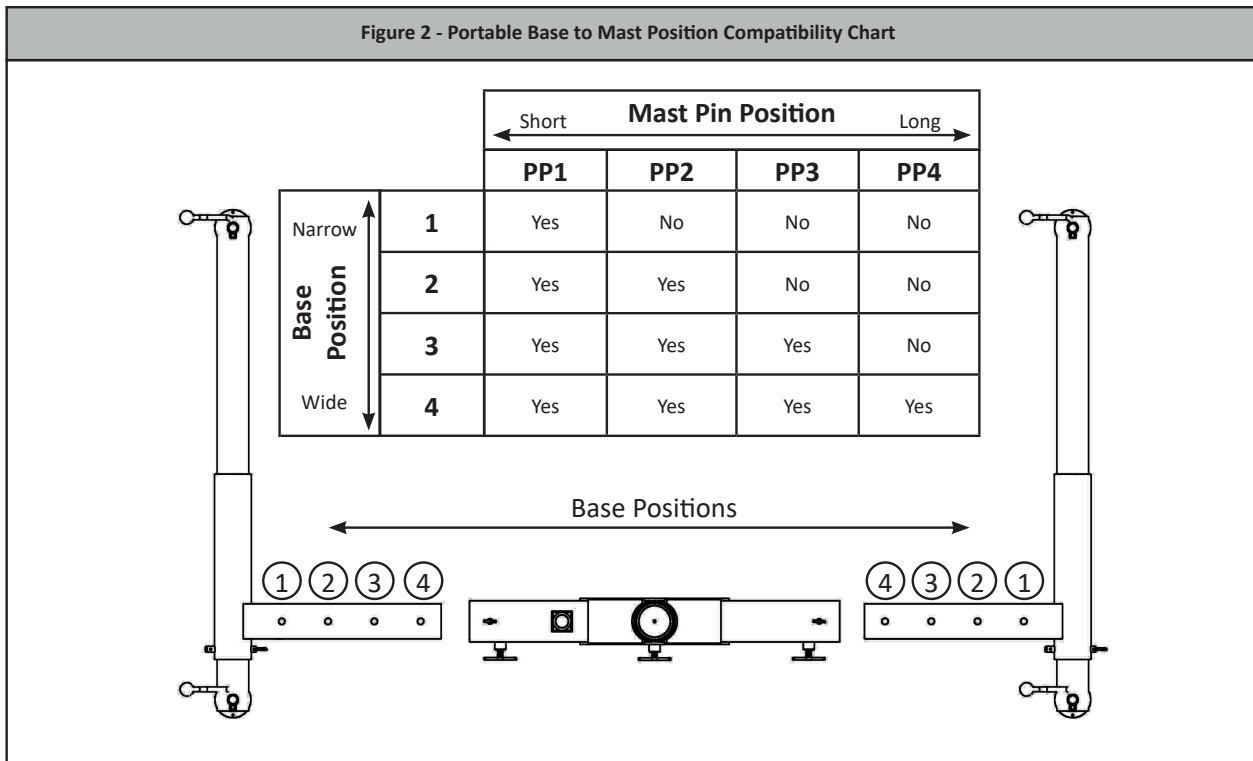

Figure 2 - Portable Base to Mast Position Compatibility Chart



3.0 System Requirements

- 3.1 **Compatibility of Connectors:** Connectors are considered to be compatible with connecting elements when they have been designed to work together in such a way that their sizes and shapes do not cause their gate mechanisms to inadvertently open regardless of how they become oriented. Contact FallTech if you have any questions about compatibility. Connectors must be compatible with the anchorage or other system components. Do not use equipment that is not compatible. Non-compatible connectors may unintentionally disengage. Connectors must be compatible in size, shape, and strength. Self-closing, self-locking snap hooks and carabiners are specified by OSHA and ANSI Z359.12.
- 3.2 **Compatibility of Components:** Equipment is designed for use with approved components and subsystems only. Substitutions or replacements made with non-ANSI Z359 compliant components or subsystems may jeopardize compatibility of equipment and may affect the safety and reliability of the complete system. Ensure compatibility between the connectors if non-FallTech components are used for fall protection.
- 3.3 **Connectors:** Only use self-locking snap hooks, rebar hooks, and carabiners with this equipment. Only use connectors that are suitable to each application. Ensure all connections are compatible in size, shape and strength. Do not use equipment that is not compatible. Visually ensure all connectors close and lock completely. Connectors (snap hooks, rebar hooks, and carabiners) are designed for use only as specified in this manual.

4.0 Installation and Use

- 4.1 **General Rescue Requirements:** The equipment specified in this manual is designed to work as part of a system to help facilitate non-entry rescue and entry rescue from confined spaces.

Confined spaces vary in size, shape, configuration and hazard, and the equipment/device(s) detailed in this manual may not be suitable for use during some permit-required confined space entries. Hazards such as entanglement, electric arc, engulfment, and general lift obstructions may interfere with safe rescue and cause greater harm to the entrant.

All confined space entries should be planned whenever possible in such a manner that any foreseeable hazard is mitigated and non-entry rescue can be facilitated.

In the case that non-entry rescue is not feasible, a rescue plan must be in place that provides rescuers with knowledge about the specific confined space hazards they may encounter during a rescue, training on appropriate rescue methods for the confined space they will be entering and the correct equipment and PPE to perform the entry rescue. Please reference OSHA code CFR 1926.1211 and ANSI Z117.1-2016 for further details on employer responsibilities in preparing for both entry and non-entry rescue.

4.2 System Configurations for Non-Entry Rescue Methods: When entering a permit-required confined space, non-entry rescue is required unless retrieval equipment would increase the overall risk of entry or would not contribute to the rescue of the worker. Mechanical devices must be available to retrieve personnel from vertical type permit spaces more than 5 feet deep. When using mechanical devices for non-entry rescue, consideration must be given to the means of entry/egress, the mitigation of fall hazards and the method of emergency retrieval.

4.2.1 Single Line – Winch Only – Entry/Egress Using Ladder

When a single mechanical device is used for non-entry rescue into a confined space it serves only as backup to the worker’s primary entry/egress method. In most cases the primary means of entry/egress into a vertical confined space is a ladder. When using only a winch as the backup to the entrant’s primary means of entry and egress, the attendant should take care to keep the winch line taut to avoid any potential overload due to a fall event on the winch line. The winch is not a fall arrest device and must not be subjected to fall forces. The winch is for emergency retrieval only. See Figure 3.

4.2.2 Single Line – 3-Way Only – Entry/Egress Using ladder

When a single mechanical device is used for non-entry rescue into a confined space it serves only as backup to the worker’s primary entry/egress method. In most cases the primary means of entry/egress into a vertical confined space is a ladder. When using an SRL-R only as a back up to the worker’s primary means of entry and egress the device cable will pay freely in and out of the housing as the entrant moves into the vertical confined space. In the event the entrant falls the SRL-R will arrest the fall and reduce fall forces applied to the body. The attendant may then engage the backup emergency retrieval winch to raise the entrant out of the confined space. The emergency retrieval winch is not to be used for ordinary entry/egress in and out of the confined space. See Figure 4.

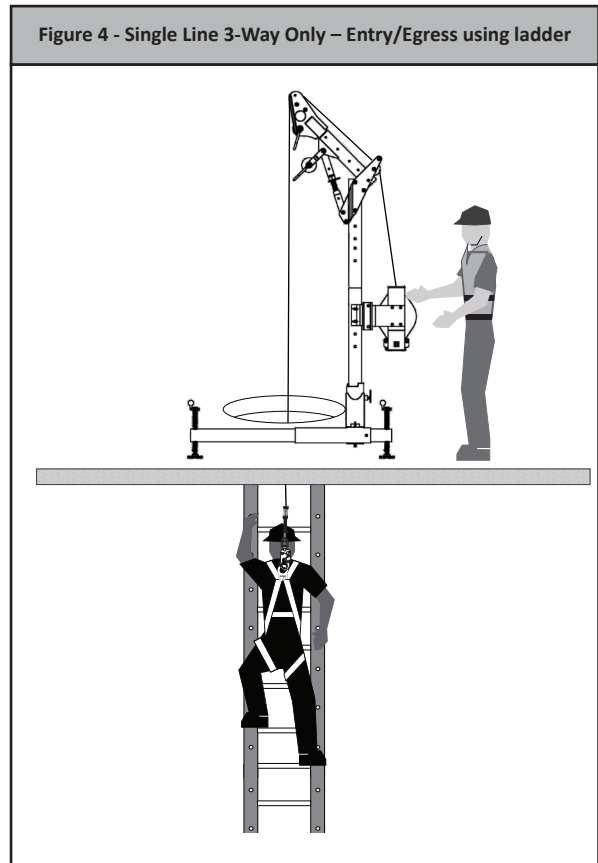
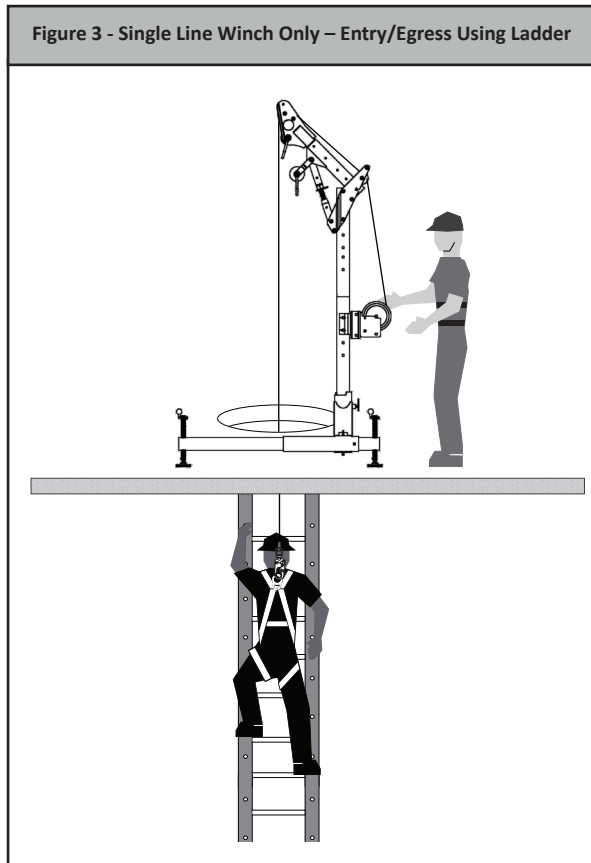

4.2.3 Dual Line – Winch and SRD/Alternate PFAS - Entry/Egress Using Ladder

When a confined space has an existing ladder but the attendant is unable to maintain a taut winch line as the entrant descends and ascends from the confined space, it is possible to use a regular SRD or Fall Arrestor Connector Subsystem (FACSS) to provide protection from impacting and overloading the winch during a fall event.

In this case the PFAS provides fall protection as the worker freely moves vertically, and the winch provides backup as the emergency retrieval device from the confined space. See Figure 5.

4.2.4 Dual Line – Winch and 3-Way – Entry/Egress Using a Winch

When no alternate method of entry/egress (such as a ladder) exists the confined space entrant will be suspended, raised and lowered with the winch line attached to a shoulder yoke or sternal D-Ring of a Full Body Harness. An SRL-R is then attached to the dorsal D-ring of the Full Body Harness to provide fall arrest and emergency retrieval. Suspended workers are required to have a backup system to their primary means of entry/egress that will limit fall forces to the body and provide emergency retrieval in the event of a winch malfunction. See Figure 6.

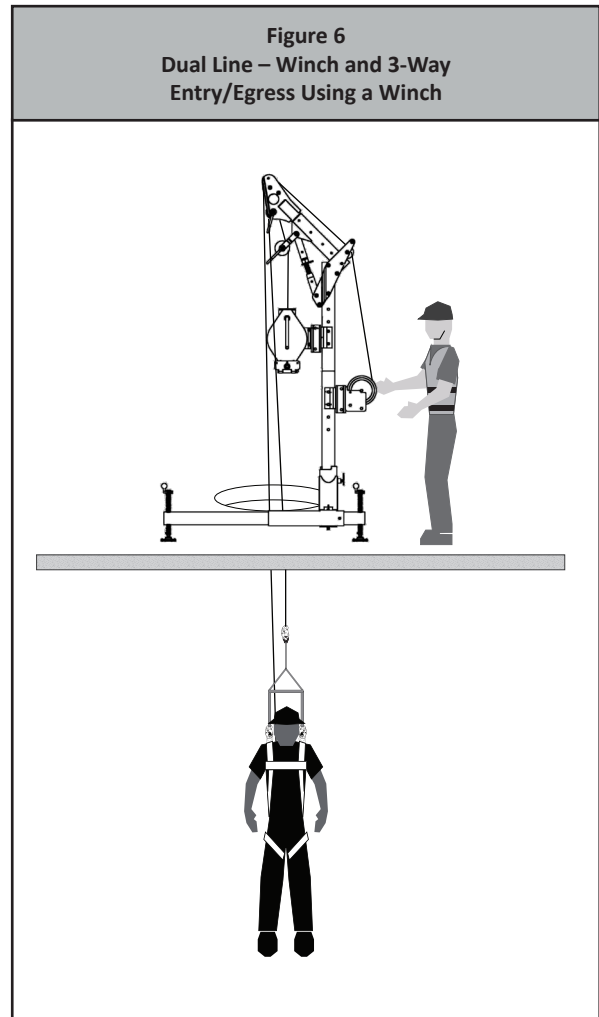
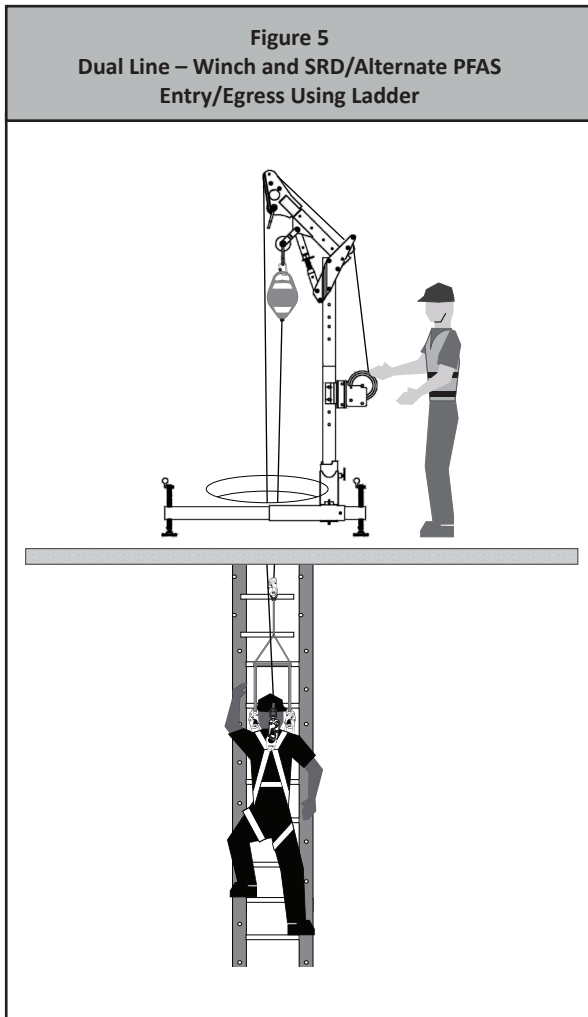

4.3 Davit Assembly

Step 1 - Portable Base

The davit base legs are shipped in a different orientation to optimize packaging and storage when not in use, Figure 7. To assemble, the legs must be rotated from the packed position to the proper orientation for use. On both legs, remove the detent pins as shown in Figure 8, rotate the round tube of the leg to the use position as shown in Figure 9 and align the holes of the round tubes and reinsert the detent pins as shown in Figure 10.

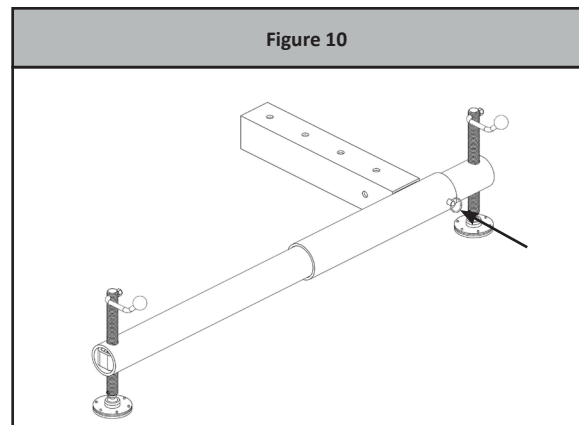
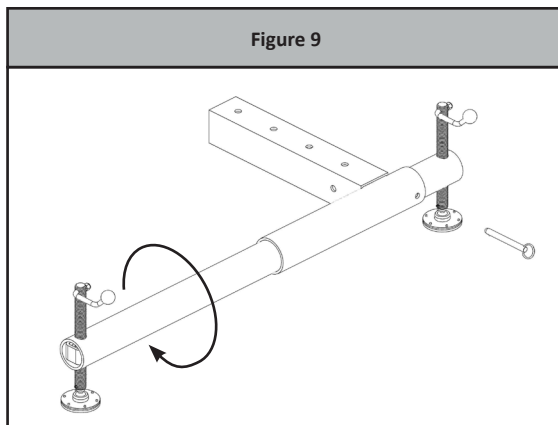
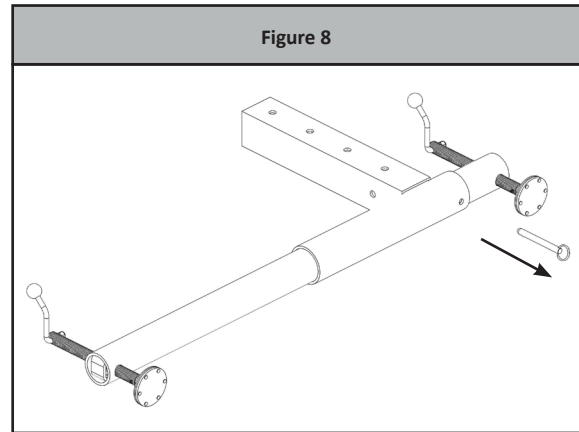
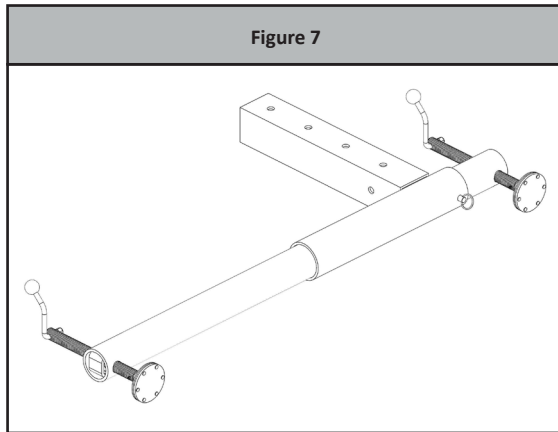

Before inserting the legs into the base center section, refer to the table in Figure 2 to match the Base Position with the Pin Positions of the Davit Arm. To install the Davit Base Legs, ensure the red thumb screws are loosened (turn counter-clockwise). Insert the legs into the base center section and determine the offset your application requires, align the holes and insert the detent pins, Figure 11. Tighten the red thumb screws (clockwise) to ensure are locked in place as shown in Figure 12.

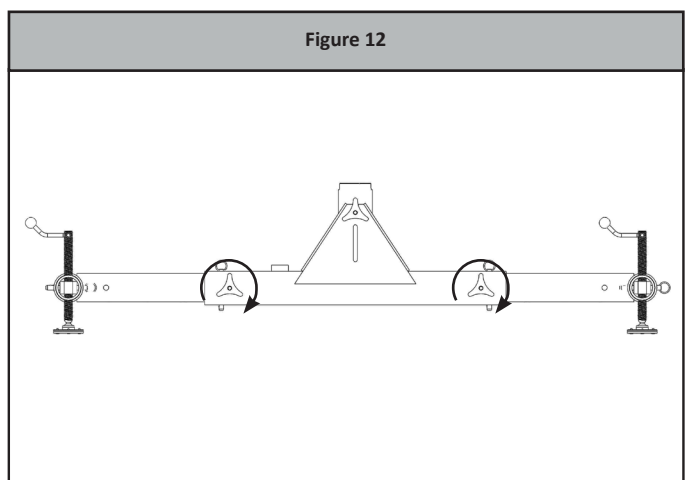
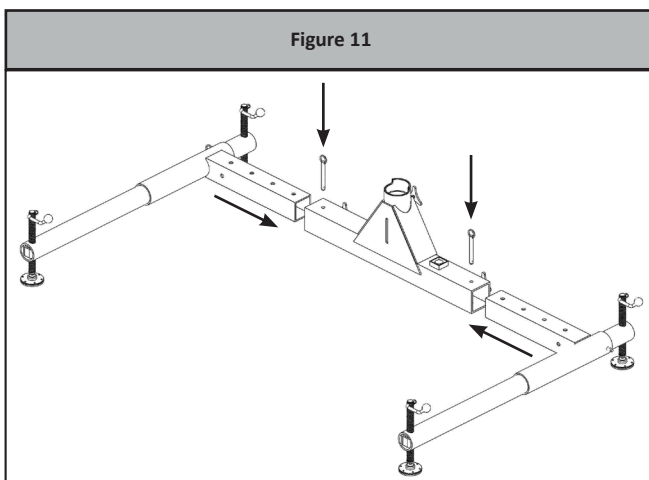

Step 2 - Lower Mast Extension

Place the Portable Base in the location suitable for the application. Insert the Lower Mast Extension (Figure 13) in the Portable Base into the base sleeve with the position limiting bolt front of the base as shown in Figure 14. Only one length Mast Extension can be used at a time. Do not use more than one Mast Extension when setting up the davit arm. See Appendix A for compatible Mast Extensions.

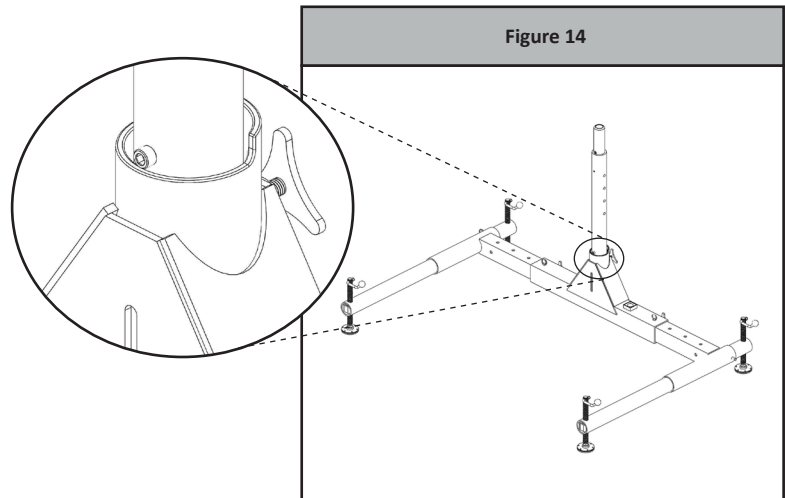
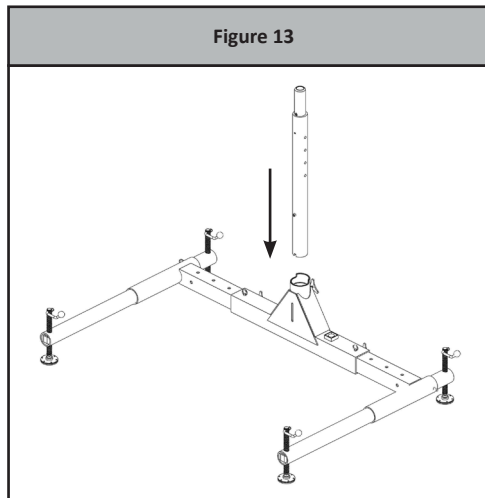

Step 3 - Davit Arm

The davit arm is shipped in a folded position, Figure 15. Remove the push button pin as shown in Figure 16. Rotate the the arm into position and align the top tube hole with the hole in the bracket, Figure 17. Insert the push button pin as shown in Figure 18.

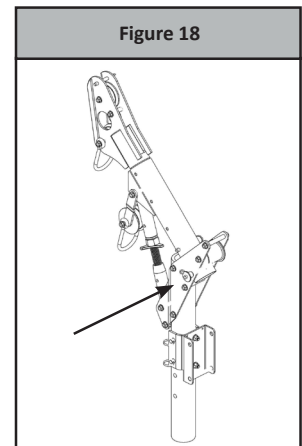
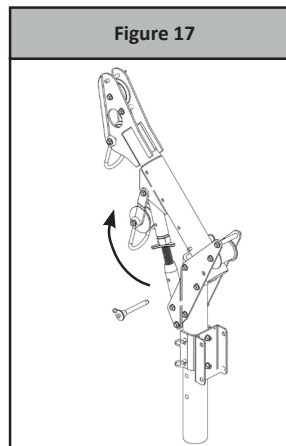
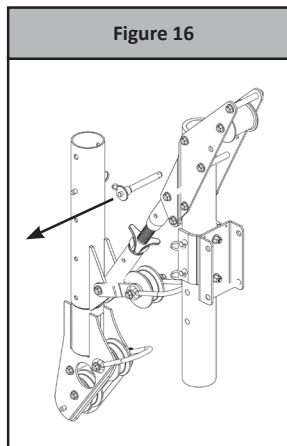
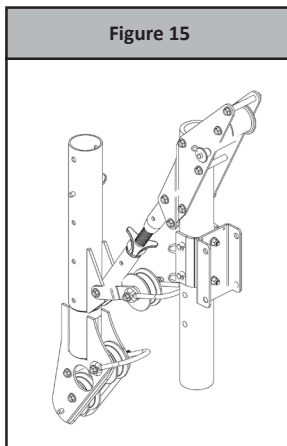

Lift the Davit Arm and place it onto the Lower Mast Extension, Figure 19. Ensure the bolt on the Lower Mast Extension fits into the Davit Arm mating notch as shown in Figure 20.

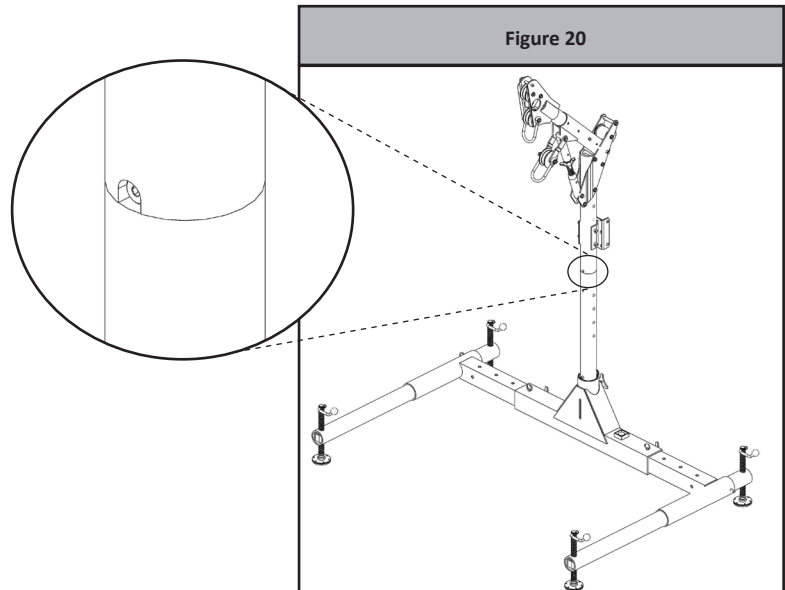
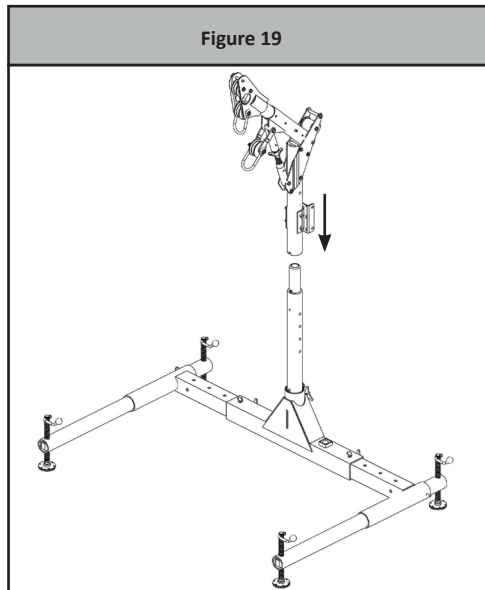

Step 4 - Leveling

When using the Confined Space 5-Piece Davit System, the base must be level at all times with the legs pinned and tightened in place.

To level of the davit, adjust each leg height until the bubble is centered in the bubble level, Figure 21.

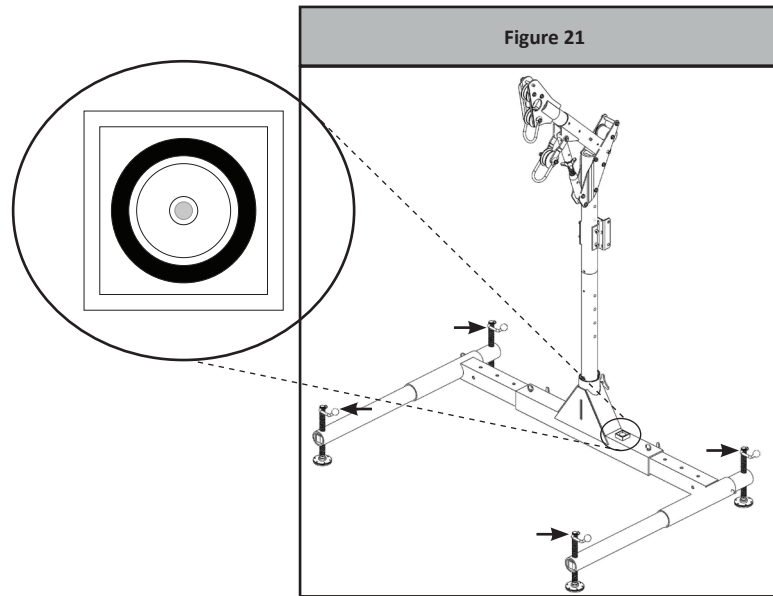

Step 5 - Fine Offset Adjustment

The Confined Space 5-Piece Davit System is equipped with a fine adjustment screw to help ensure the anchor point is centered over the entry/egress location. To adjust, turn the fine adjustment screw to raise and lower the arm to the desired position, Figure 22.

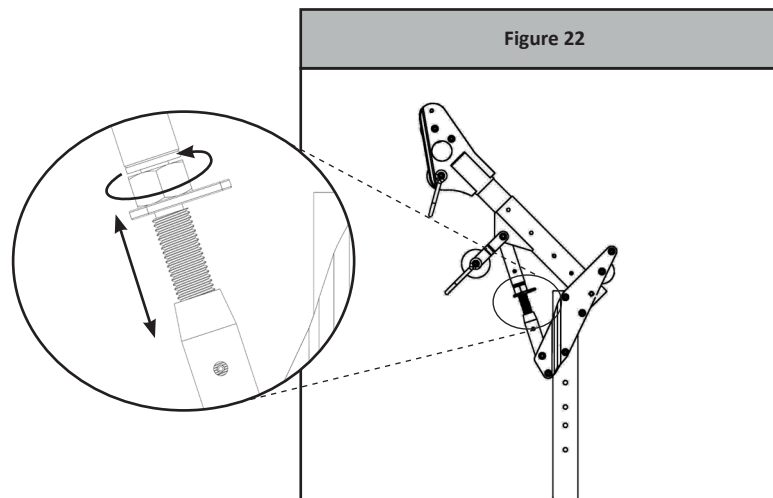

Step 6 - Winch/3-Way Installation

Based on your application, attach the FallTech Davit Device Receiver Bracket to the davit using the provided detent pins. See Figure 23 for correct and Figure 24 for incorrect orientations of the Davit Receiver Bracket. **DO NOT** mount any device on the front of the lower mast.

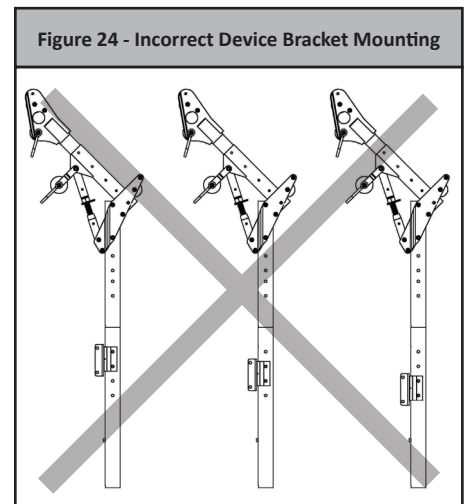
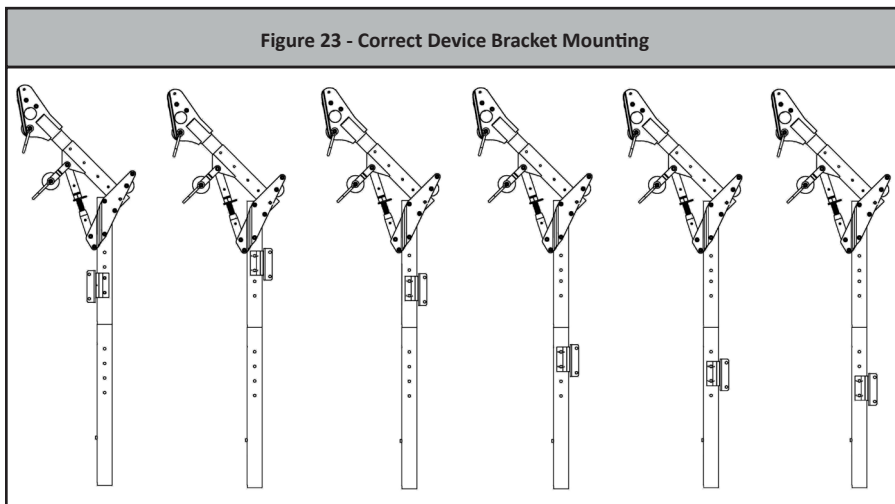

To attach a winch or 3-Way to the Davit Device Receiver Bracket, place the notch in the device side bracket over the bottom bar of the bracket as shown in Figure 25. Rotate to align the upper holes (Figure 26) on the bracket and insert the provided detent pin, Figure 27.

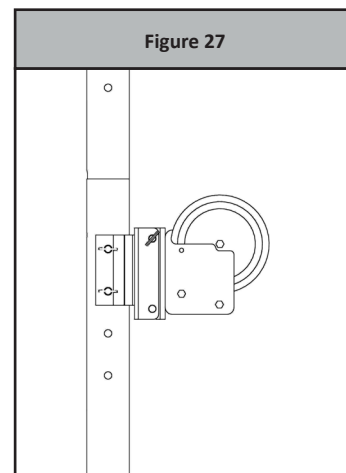
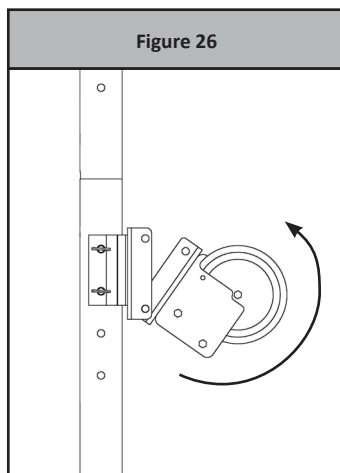
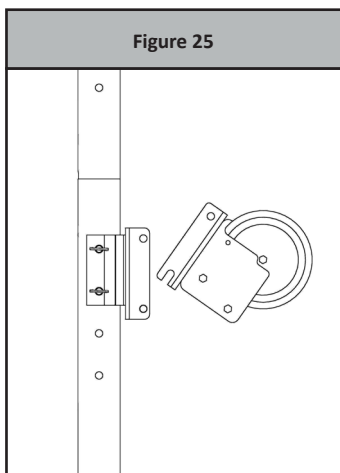

Step 7 - Cable Routing

If using a rear mounted device, use the Top Pulley Anchor (TP), run the line of the over the rear pulley of the Davit Arm, remove the detent pin and run the line over the front pulley and reinsert the detent pin, Figure 28. If using a front mounted device use the Bottom Pulley Anchor (BP), run the line of the over the front bottom pulley and around lower pulley in the front of the davit arm, Figure 29. The lifeline must be routed through both pulleys for all front mounted devices.

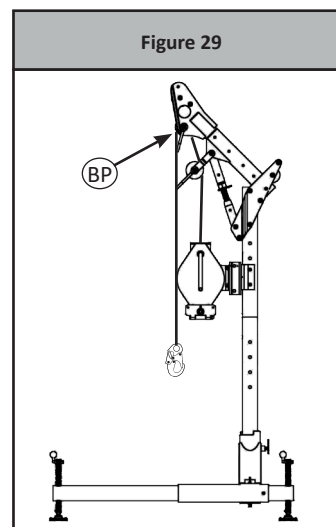
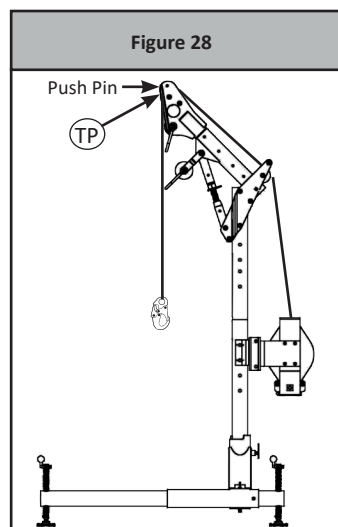

5.0 Maintenance, Service and Storage

- Maintenance:** No scheduled maintenance is required, other than the replacement of items that failed inspection.
- Service:** There are no specific service requirements for this system component.
- Storage:** If the unit is removed from its installation location, it should be stored in a dry area free of corrosive elements that may harm or cause the product not to function.

6.0 Inspection

6.1 Pre-Use Inspection:

- 6.1.1 Inspect the additional equipment used on the davit arm per the user instruction manual for the specific equipment. Do not use if the equipment fails inspection.
- 6.1.2 Inspect the Confined Space 5-Piece Davit System thoroughly for damage, inspection should include checking the structure for dents, cracks, deformed or bent tubing.
- 6.1.3 Inspect all hardware for damage, wear or missing parts.
- 6.1.4 Check all rollers and pulleys for to ensure proper movement, check for damage such as cracks, chips and excessive wear.
- 6.1.5 Ensure all detent pins are properly secured before every use.

Do not use the FallTech Confined Space Davit or additional equipment if it fails any part of this inspection.

6.2 Inspection Frequency:

Pre-Use: Inspect the Confined Space 5-Piece Davit System and additional equipment weekly as outlined in section 6.1. All installations must be approved to local standards by a Qualified Person.

Annually: The Confined Space 5-Piece Davit System and additional equipment must be inspected by a Qualified Person annually and recorded on the Inspection Record provided or equivalent document.

INSPECTION RECORD <i>PLANILLA de INSPECCIÓN</i>					
Model # <i>Modelo N°</i> : _____			Serial # <i>N° de serie</i> : _____		
Date of Manufacture <i>Fecha de fabricación</i> : _____					
Inspection Date <i>Fecha de inspección</i>	Inspector <i>Inspector</i>	Comments <i>Observaciones</i>	Pass/Fail <i>Pasó/No pasó</i>	Corrective Action Needed <i>Accion correctiva a realizar</i>	Approved By <i>Aprobado por</i>

7.0 Labels

The labels must be present and legible.

Daivit Arm Labels

FALLTECH
 CONFINED SPACE DAVIT 412-01651 Rev A

OFFSET LENGTH AND LOAD RATING CHART

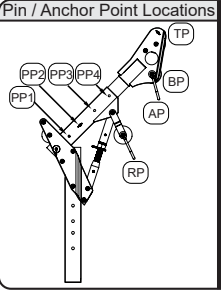

Pin / Anchor Point Locations		Arm Offset Lengths			
		PP1	PP2	PP3	PP4
Offset Range		11.75" to 19.25"	13.5" to 22"	16" to 25.5"	18.5" to 29.25"
Anchor Point		Acceptable Load Ratings			
		Mast Pin Position			
Anchor Point	AP	3600lbs	3600lbs	3100lbs	2500lbs
	TP	1800lbs	1800lbs	1800lbs	1800lbs
	BP	1800lbs	1800lbs	1800lbs	1800lbs
	RP	5000lbs	5000lbs	5000lbs	5000lbs

DO NOT REMOVE LABEL

FALLTECH
 CONFINED SPACE DAVIT

WARNING

All manufacturer's instructions, labels, and warnings must be read before use and followed at all times for proper use, maintenance, and inspection. Failure to follow instructions or misuse of this system may result in serious injury or death. Inspect before each use, following guidelines found in the user's manual. This device must be installed by a competent person with the approval of a qualified person and operated under the supervision of a competent person. This component is rated for a maximum moment of 5,750 ft-lbs. Self-retracting devices or shock absorbing lanyards must have AVERAGE ARRESTING FORCE of 900 lbs. OR LESS, to provide a 2:1 safety factor in all system configurations. Exercise caution when using this device near hazardous, thermal, electrical, or chemical sources. Do not use if unsafe conditions are present. If this product has been subjected to a fall event or falls inspection, remove from service immediately. Always log inspection results in the user's manual and on the inspection grid label.

412-01649 Rev A

DO NOT REMOVE LABEL

FALLTECH
 CONFINED SPACE DAVIT

800.719.4619 www.falltech.com

Model#:
 Date of Mfr:
 Serial #:

412-01648 Rev A

WARNING Read User Instruction Manual Before Use.

DO NOT REMOVE LABEL

FALLTECH
RESCUE POINT

This is a 5,000 lbs rated anchor point; acceptable for rescue equipment. See user instruction manual.

412-01653 Rev A

DO NOT REMOVE LABEL

FALLTECH
 CONFINED SPACE DAVIT 412-01652 Rev A

INSPECTION GRID

MARK ON DATE GRID
 A) INITIAL SERVICE DATE
 B) DATE OF PASSED INSPECTION.
 IF UNIT FAILS INSPECTION REMOVE IT FROM SERVICE.
 SEE USER INSTRUCTION MANUAL FOR INSPECTION GUIDELINES.

	J	F	M	A	M	J	J	A	S	O	N	D

DO NOT REMOVE LABEL

PP1
 412-01654 Rev A

READ USER INSTRUCTION MANUAL

PP2
 412-01655 Rev A

READ USER INSTRUCTION MANUAL

PP3
 412-01656 Rev A

READ USER INSTRUCTION MANUAL

PP4
 412-01657 Rev A

READ USER INSTRUCTION MANUAL

Mast Extension Labels

FALLTECH
 CONFINED SPACE DAVIT 412-01972 Rev A

MAST HEIGHT

This mast is the following height.

21" 33" 45" 57"

DO NOT REMOVE LABEL

FALLTECH CONFINED SPACE DAVIT 412-01652 Rev A

INSPECTION GRID

MARK ON DATE GRID
 A) INITIAL SERVICE DATE
 B) DATE OF PASSED INSPECTION.
 IF UNIT FAILS INSPECTION REMOVE IT FROM SERVICE.
 SEE USER INSTRUCTION MANUAL FOR INSPECTION GUIDELINES.

	J	F	M	A	M	J	J	A	S	O	N	D

DO NOT REMOVE LABEL

FALLTECH
 CONFINED SPACE DAVIT

800.719.4619 www.falltech.com

Model#:
 Date of Mfr:
 Serial #:

WARNING Read User Instruction Manual Before Use.

DO NOT REMOVE LABEL

FALLTECH
 CONFINED SPACE DAVIT

WARNING

All manufacturer's instructions, labels, and warnings must be read before use and followed at all times for proper use, maintenance, and inspection. Failure to follow instructions or misuse of this system may result in serious injury or death. Inspect before each use, following guidelines found in the user's manual. This device must be installed by a competent person with the approval of a qualified person and operated under the supervision of a competent person. This component is rated for a maximum moment of 5,750 ft-lbs. Self-retracting devices or shock absorbing lanyards must have AVERAGE ARRESTING FORCE of 900 lbs. OR LESS, to provide a 2:1 safety factor in all system configurations. Exercise caution when using this device near hazardous, thermal, electrical, or chemical sources. Do not use if unsafe conditions are present. If this product has been subjected to a fall event or fails inspection, remove from service immediately. Always log inspection results in the user's manual and on the inspection grid label.

412-01649 Rev A

DO NOT REMOVE LABEL

3-PC Portable Base Labels

FALLTECH
 CONFINED SPACE DAVIT 412-01650 Rev A

ACCEPTABLE OFFSET LENGTHS

This base is to be used only with the following davit offset lengths:

6" 12" 18" 24" 30" 36" 42" 48"

DO NOT REMOVE LABEL

FALLTECH CONFINED SPACE DAVIT 412-01652 Rev A

INSPECTION GRID

MARK ON DATE GRID
 A) INITIAL SERVICE DATE
 B) DATE OF PASSED INSPECTION.
 IF UNIT FAILS INSPECTION REMOVE IT FROM SERVICE.
 SEE USER INSTRUCTION MANUAL FOR INSPECTION GUIDELINES.

	J	F	M	A	M	J	J	A	S	O	N	D

DO NOT REMOVE LABEL

FALLTECH
 CONFINED SPACE DAVIT

800.719.4619 www.falltech.com

Model#:
 Date of Mfr:
 Serial #:

WARNING Read User Instruction Manual Before Use.

DO NOT REMOVE LABEL

FALLTECH
 CONFINED SPACE DAVIT

WARNING

All manufacturer's instructions, labels, and warnings must be read before use and followed at all times for proper use, maintenance, and inspection. Failure to follow instructions or misuse of this system may result in serious injury or death. Inspect before each use, following guidelines found in the user's manual. This device must be installed by a competent person with the approval of a qualified person and operated under the supervision of a competent person. This component is rated for a maximum moment of 5,750 ft-lbs. Self-retracting devices or shock absorbing lanyards must have AVERAGE ARRESTING FORCE of 900 lbs. OR LESS, to provide a 2:1 safety factor in all system configurations. Exercise caution when using this device near hazardous, thermal, electrical, or chemical sources. Do not use if unsafe conditions are present. If this product has been subjected to a fall event or fails inspection, remove from service immediately. Always log inspection results in the user's manual and on the inspection grid label.

412-01649 Rev A

DO NOT REMOVE LABEL

8.0 Definitions

The following are general definitions of fall protection terms as defined by ANSI Z359.0-2012.

Anchorage - A secure connecting point or a terminating component of a fall protection system or rescue system capable of safely supporting the impact forces applied by a fall protection system or anchorage subsystem.

Anchorage Connector - A component or subsystem that functions as an interface between the anchorage and a fall protection, work positioning, rope access or rescue system for the purpose of coupling the system to the anchorage.

Arrest Distance - The total vertical distance required to arrest a fall. The arrest distance includes the deceleration distance and activation distance.

Authorized Person - A person assigned by the employer to perform duties at a location where the person will be exposed to a fall hazard.

Available Clearance - The distance from a reference point, such as the working platform, to the nearest obstruction that an authorized person might contact during a fall which, if struck, could cause injury.

Capacity - The maximum weight that a component, system or subsystem is designed to hold.

Certification - The act of attesting in writing that the criteria established by these standards or some other designated standard have been met.

Certified Anchorage - An anchorage for fall arrest, positioning, restraint or rescue systems that a qualified person certifies to be capable of supporting the potential fall forces that could be encountered during a fall.

Clearance - The distance from a specified reference point, such as the working platform or anchorage of a fall arrest system, to the lower level that a worker might encounter during a fall.

Clearance Requirement - The distance below an authorized person that must remain clear of obstructions in order to ensure that the authorized person does not make contact with any objects that would cause injury in the event of a fall.

Competent Person - An individual designated by the employer to be responsible for the immediate supervision, implementation and monitoring of the employer's managed fall protection program who, through training and knowledge, is capable of identifying, evaluating and addressing existing and potential fall hazards, and who has the employer's authority to take prompt corrective action with regard to such hazards.

Component - An element or integral assembly of interconnected elements intended to perform one function in the system.

Connecting Subsystem - An assembly, including the necessary connectors, comprised of all components, subsystems, or both, between the anchorage or anchorage connector and the harness attachment point.

Connector - A component or element that is used to couple parts of the system together.

Deceleration Distance - The vertical distance between the user's fall arrest attachment at the onset of fall arrest forces during a fall, and after the fall arrest attachment comes to a complete stop.

Energy (Shock) Absorber - A component whose primary function is to dissipate energy and limit deceleration forces which the system imposes on the body during fall arrest.

Fall Arrest - The action or event of stopping a free fall or the instant where the downward free fall has been stopped.

Fall Hazard - Any location where a person is exposed to a potential free fall.

Free Fall - The act of falling before a fall protection system begins to apply forces to arrest the fall.

Free Fall Distance - The vertical distance traveled during a fall, measured from the onset of a fall from a walking working surface to the point at which the fall protection system begins to arrest the fall.

Harness, Full Body - A body support designed to contain the torso and distribute the fall arrest forces over at least the upper thighs, pelvis, chest and shoulders.

Horizontal Lifeline - A component of a horizontal lifeline subsystem, consisting of a flexible line with connectors or other coupling means at both ends for securing it horizontally between two anchorages or anchorage connectors.

Horizontal Lifeline Subsystem - An assembly, including the necessary connectors, comprised of a horizontal lifeline component and, optionally, of:
a) An energy absorbing component or, b) A lifeline tensioner component, or both. This subsystem is normally attached at each end to an anchorage or anchorage connector. The end anchorages have the same elevation.

Horizontal Lifeline – A component of a horizontal lifeline subsystem, consisting of a flexible line with connectors or other coupling means at both ends for securing it horizontally between two anchorages or anchorage connectors.

Horizontal Lifeline Subsystem – An assembly, including the necessary connectors, comprised of a horizontal lifeline component and, optionally, of:
a) An energy absorbing component or, b) A lifeline tensioner component, or both. This subsystem is normally attached at each end to an anchorage or anchorage connector. The end anchorages have the same elevation.

Lanyard - A component consisting of a flexible rope, wire rope or strap, which typically has a connector at each end for connecting to the body support and to a fall arrester, energy absorber, anchorage connector or anchorage.

Lanyard Connecting Subsystem - An assembly, including the necessary connectors, comprised of a lanyard only, or a lanyard and energy absorber.

Personal Fall Arrest System (PFAS) - An assembly of components and subsystems used to arrest a person in a free fall.

Positioning - The act of supporting the body with a positioning system for the purpose of working with hands free.

Positioning Lanyard - A lanyard used to transfer forces from a body support to an anchorage or anchorage connector in a positioning system.

Qualified Person - A person with a recognized degree or professional certificate and with extensive knowledge, training and experience in the fall protection and rescue field who is capable of designing, analyzing, evaluating and specifying fall protection and rescue systems.

Self-Retracting Device (SRD) - A device that contains a drum wound line that automatically locks at the onset of a fall to arrest the user, but that pays out from and automatically retracts onto the drum during normal movement of the person to whom the line is attached.

After onset of a fall, the device automatically locks the drum and arrests the fall. Self-retracting devices include self-retracting lanyards (SrL's), self-retracting lanyards with integral rescue capability (SrL-r's), and self-retracting lanyards with leading edge capability (SrL-Le's) and, hybrid combinations of these.

Snaphook - A connector comprised of a hook-shaped body with a normally closed gate or similar arrangement that may be opened to permit the hook to receive an object and, when released, automatically closes to retain the object.

Swing Fall - A pendulum-like motion that occurs during and/or after a vertical fall. A swing fall results when an authorized person begins a fall from a position that is located horizontally away from a fixed anchorage.

The following are general definitions of fall protection terms as defined by OSHA 1910.146.

Confined Space - OSHA defines a Confined Space as:

- Is large enough for an employee to enter fully and perform assigned work;
- Is not designed for continuous occupancy by the employee; and
- Has a limited or restricted means of entry or exit.



These spaces may include underground vaults, tanks, storage bins, pits and diked areas, vessels, silos and other similar areas.

Permit Required Confined Space has one or more of these characteristics:

- Contains or has the potential to contain a hazardous atmosphere;
- Contains a material with the potential to engulf someone who enters the space;
- Has an internal configuration that might cause an entrant to be trapped or asphyxiated by inwardly converging walls or by a floor that slopes downward and tapers to a smaller cross section; and/or
- Contains any other recognized serious safety or health hazards.

Appendix A

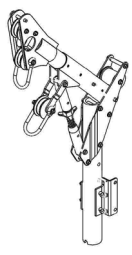
Table 1: Specifications for 5-PC Confined Space Davit System

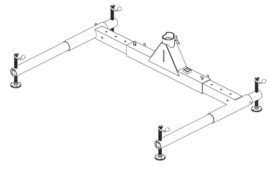
Part Numbers	Minimum Tensile Strength and Material	Maximum User Capacity	Standards & Regulations	Kit Contents
11" - 28" Offset Arm 6500128	6061-T6 Aluminum Zinc Plated Steel	Maximum Two Workers at up to 310 lbs. Each (620 lbs Total) for Rescue Configurations Maximum One Worker up to 310 lbs. for Normal Confined Space Entry/Egress Operations	OSHA 1926.502	
Lower Mast/Extensions 6500321 6500433 6500545 6500657	Minimum 5,750 ft-lb Moment Rated Minimum 5,000 lbs Rated in Rescue Point Configuration			
3PC Portable Base 6500728	Minimum 1,800 lbs Rated in Normal Operation See Figure 1 for Complete Minimum Load Ratings			

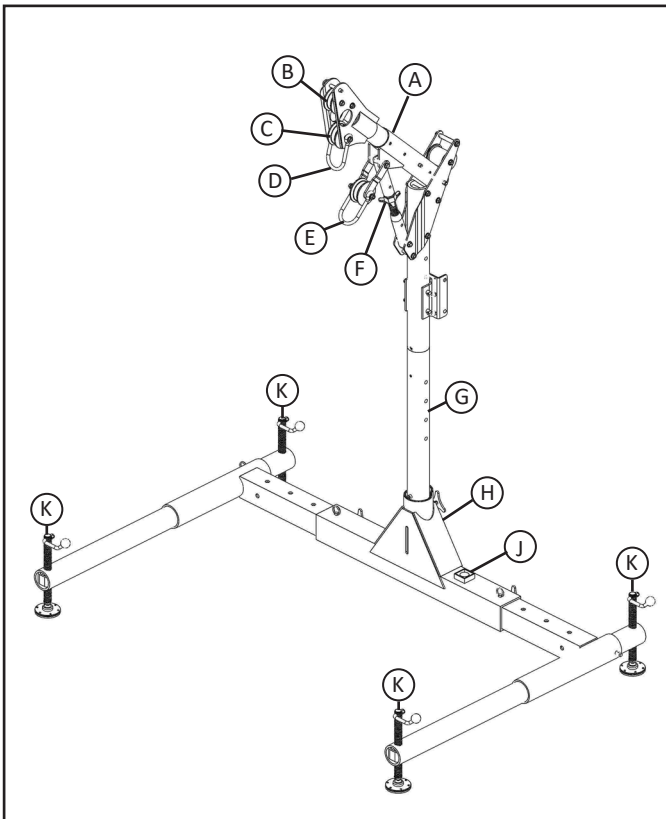

A	11" to 28" Offset Davit Arm
B	Top Pulley (TP)
C	Bottom Pulley (BP)
D	Anchor Point (AP)
E	Rescue Point (RP)
F	Fine Offset Adjustment Screw
G	Lower Mast/Extension
H	3PC Portable Base
J	Bubble Level
K	Adjustable Height Leg

List of Compatible Lower Mast/Extensions	
6500321	Lower Mast Extension 21" for Confined Space Davits
6500433	Lower Mast Extension 33" for Confined Space Davits
6500545	Lower Mast Extension 45" for Confined Space Davits
6500657	Lower Mast Extension 57" for Confined Space Davits

List of Compatible Bases and Sleeves	
6500728	3pc Portable Base-only for 11" to 28" Offset Davit Arm
6501528	3pc Vehicle Hitch-mount Base for 11" to 28" Offset Davit Arm
65020BFZ	Flush-mount Sleeve Zinc for Confined Space Davit
65020BFS	Flush-mount Sleeve SST for Confined Space Davit
65030CFZ	Flush-mount Sleeve Zinc for Confined Space Davit
65030CFS	Flush-mount Sleeve SST for Confined Space Davit
65040CMZ	Flush-mount Sleeve SST for Confined Space Davit
65040CMS	Center-mount Sleeve SST for Confined Space Davit
65050CRZ	Core-mount Sleeve Zinc for Confined Space Davit
65050CRS	Core-mount Sleeve SST for Confined Space Davit
65060FMZ	Floor-mount Sleeve Zinc for Confined Space Davit
65060FMS	Floor-mount Sleeve SST for Confined Space Davit
65070WMZ	Wall-mount Sleeve Zinc for Confined Space Davit
65070WMS	Wall-mount Sleeve SST for Confined Space Davit
65080SCZ	Sleeve Cap Zinc for Confined Space Sleeves
65080SCS	Sleeve Cap SST for Confined Space Sleeves
65095FCZ	Floor-mount Sleeve, Cracked Concrete Zinc for Confined Space Davit
65095FCS	Floor-mount Sleeve, Cracked Concrete SST for Confined Space Davit
65096WCZ	Wall-mount Sleeve, Cracked Concrete Zinc for Confined Space Davit
65096WCS	Wall-mount Sleeve, Cracked Concrete SST for Confined Space Davit

Note: The above listing shows the most common FallTech masts, bases and sleeves that are compatible with the FallTech Confined Space Davit System. Contact FallTech for additional information regarding other components not on this list.