

# FRONTLINE

FALL PROTECTION

## Installation, Operating, Inspection and Maintenance Instructions 7 ft. Tripod for Confined Space Entry

Model #: TAN07-US



Shown with: RAG503W-  
US 3-way SRL and  
PUS34-US Pulley  
available separately

### **Warning**

You must read and fully understand all instructions, or have all instructions explained to you, before attempting to use this equipment. Equipment must not be installed, operated or inspected by anyone who does not understand this Guide. Failure to observe these instructions could result in serious injury or death. Careless or improper use of this equipment can result in serious injury or death. Training and instruction review should be repeated at regular intervals. If you have any questions regarding these instructions or need additional copies, contact Frontline Fall Protection at: [www.FrontlineFall.com](http://www.FrontlineFall.com) or [info@FrontlineFall.com](mailto:info@FrontlineFall.com)

**IMPORTANT: THESE INSTRUCTIONS SHOULD BE KEPT  
WITH THE DEVICE AT ALL TIMES.**

## Description:

Frontline Tripods (Figs. 2 & 3) are designed to be used principally with Frontline 3-way SRLs (9) and other SRLs (10). Tripods provide a convenient, portable attachment point which can be moved from place to place, as needed. The tripod's legs (7) can be adjusted to accommodate unevenness of footing within reasonable limits.

Care should be taken to ensure that all equipment will be clear of electrical hazards and that proper ventilation has been provided in the work area before the worker descends into the confined space. All users must wear a full-body harness that complies with OSHA, so that an injured worker can be winched up and retrieved through an opening without having another person enter the confined workspace.

Personnel using the confined space safety system and personnel that may be required to perform a rescue operation must be instructed in the correct use of the system. All operators must read and understand all instructions pertaining to the use of the system and must be trained in its proper use. Refer to and follow all federal, state, and local standards/regulations that pertain to this type of equipment.

## Specifications:

<b>Model Number</b>	TAN07-US
<b>Minimum Breaking Strength (MBS)</b>	5000 lbs.
<b>Height with legs at minimum extension</b>	4' (48")
<b>Height with legs at maximum extension</b>	7' (84")
<b>Distance between feet at minimum extension</b>	38"
<b>Distance between feet at maximum extension</b>	60"
<b>Size for transport and storage:</b>	
<b>Length</b>	55"
<b>Diameter</b>	16"
<b>Weight</b>	40 lbs.
<b>Standards Compliance</b>	OSHA, ANSI Z359.1, Z359.4, Z359.18

## Training:

From OSHA 1910.146 (see The Federal Register for the full text)

(g) Training.

(1) The employer shall provide training so that all employees whose work is regulated by this section acquire the understanding, knowledge, and skills necessary for the safe performance of the duties assigned under this section.

(2) Training shall be provided to each affected employee:

(i) Before the employee is first assigned duties under this section;

(ii) Before there is a change in assigned duties;

(iii) Whenever there is a change in permit space operations that presents a hazard about which an employee has not previously been trained;

(iv) Whenever the employer has reason to believe either that there are deviations from the permit space entry procedures required by paragraph (d)(3) of this section or that there are inadequacies in the employee's knowledge or use of these procedures.

(3) The training shall establish employee proficiency in the duties required by this section and shall introduce new or revised procedures, as necessary, for compliance with this section.

(4) The employer shall certify that the training required by paragraphs (g)(1) through (g)(3) of this section has been accomplished. The certification shall contain each employee's name, the signatures or initials of the trainers, and the dates of training. The certification shall be available for inspection by employees and their authorized representatives.

## Installation:

1. Position telescoped tripod alongside manhole or other opening.
2. Remove locking pin (1) from each leg (7), extend legs to maximum length and reinsert pin.
3. Elevate tripod and spread legs to maximum width. Tripod legs should automatically lock in position.

**Note:** Make certain that leg locks (2) in tripod head (5) spring into locked position. The leg chain (3) must be used to ensure maximum strength and to add stability on uneven terrain.

### **Mounting 3-way SRL to Tripod** (*refer to SRL instructions*):

The SRL is furnished with a mounting bracket and locking pins for attachment to a Frontline tripod. The device can be mounted to any leg of the tripod; position the device on the tripod leg and align the holes in the mounting bracket with the holes in the tripod leg. Secure device with locking pins. Check that pin bearings are completely through bracket and are fully extended. Insert locking clips in holes at end of locking pins. Extend cable out of housing, open pulley by sliding sides in opposite directions, place cable over pulley sheave and close pulley. Attach pulley to snaphook on the head of the tripod. Attach locking swivel snaphook to back D-ring of appropriate full-body harness.

## Inspection:

### **BEFORE EACH USE**

All equipment must be inspected before each use; if bent, damaged, if parts have been substituted or if operation is questionable in any way, **DO NOT USE**. Contact Frontline for reconditioning or repair information.

**Note:** Make certain that leg locks (2) in tripod head (5) spring into locked position. The leg chain must be installed and in good condition to ensure compliance with strength requirements of applicable standards.

### **Inspect work area:**

Inspect and clear the vicinity around the work area of debris and other materials that could cause injuries or interfere with the operation of the device.

## Warnings:

### DO NOT USE IF:

- The device appears to be damaged.
- The leg chain is missing.
- The leg locks in the tripod head do not function properly.
- The eyebolts (4) are missing or damaged
- **DO NOT** attempt to adjust, repair or modify Frontline Tripods; for prompt repair or reconditioning, contact Frontline.
- **DO NOT** use for other than intended purpose.
- **DO NOT** exceed maximum recommended working load.
- **NEVER** work above the anchor point.
- **ALWAYS** work directly under the anchor point. Worker must be vertically in line with device to avoid swing-fall injuries (pendulum effect)

## Swing Fall Hazard

Work directly under your anchorage whenever possible. If a swing fall can occur, ensure that there are no hazards in the swing fall path. Total fall distance is greater in a swing fall than in a vertical fall. Ensure that you account for the added distance when calculating Minimum Required Fall Space.

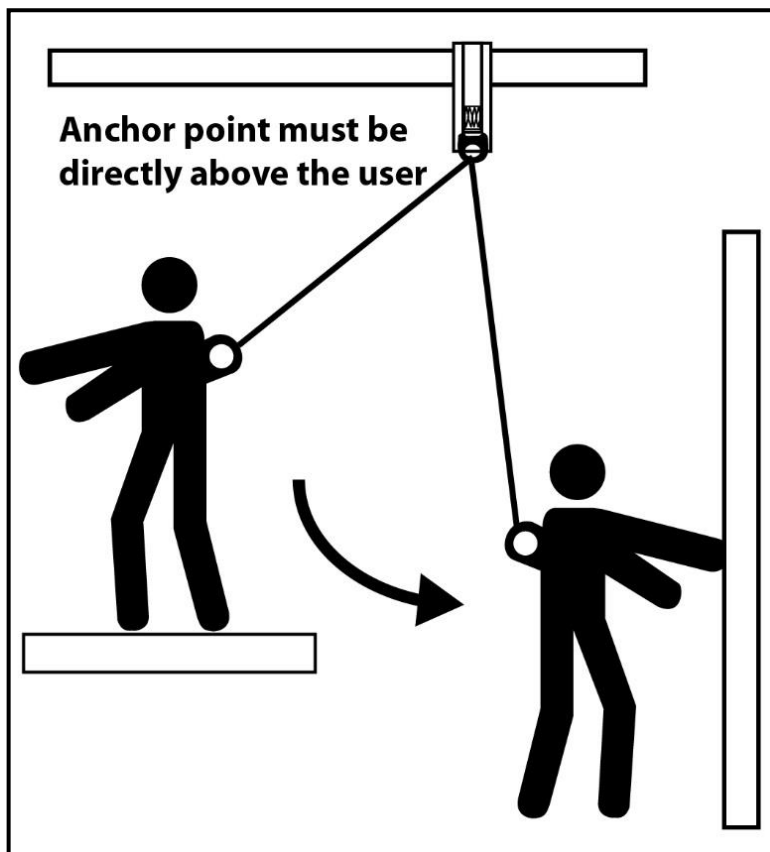

**FIGURE 1**

## Operating Instructions:

1. Mount 3-way SRL to any tripod leg using locking pins.
2. Pull (SRL mode) or winch (retrieval mode), the cable from the housing of the device and put through split sheave pulley.
3. If you are using a leg mounted device, attach the pulley to the eyebolt (4) on the tripod head (5) using a locking carabiner (available separately). If you are using a hanging SRL, connect the SRLs mounting bracket to the eyebolt (4) on the tripod head (5) using a locking carabiner (available separately). (Use center eyebolt for fall protection devices).
4. Remove manhole cover, **being sure to avoid opening**.
5. Position tripod over opening.
6. Extract cable from fall protection unit and attach snaphook to fall arrest D-ring on worker's harness (8).
7. When work is completed, reverse instructions to cover manhole, telescope tripod and remove from work location.

### Note:

- Always use hardware and related equipment which meet OSHA and ANSI standards.
- Operations should be conducted in accordance with the instructions for the equipment being used and federal, state, and local regulations.
- Always use leg chains.

Always make sure tripod legs are locked in position before working; always unlock before folding legs.

**IF YOU HAVE ANY QUESTIONS CONCERNING THE CORRECT USAGE OF THIS OR ANY FRONTLINE PRODUCT, DO NOT USE, CONTACT FRONTLINE FALL PROTECTION AT: [www.FrontlineFall.com](http://www.FrontlineFall.com) or [info@FrontlineFall.com](mailto:info@FrontlineFall.com)**

Do not try to adjust, repair or modify Frontline equipment; for prompt service, please contact Frontline. See page 8 of these instructions for contact info.

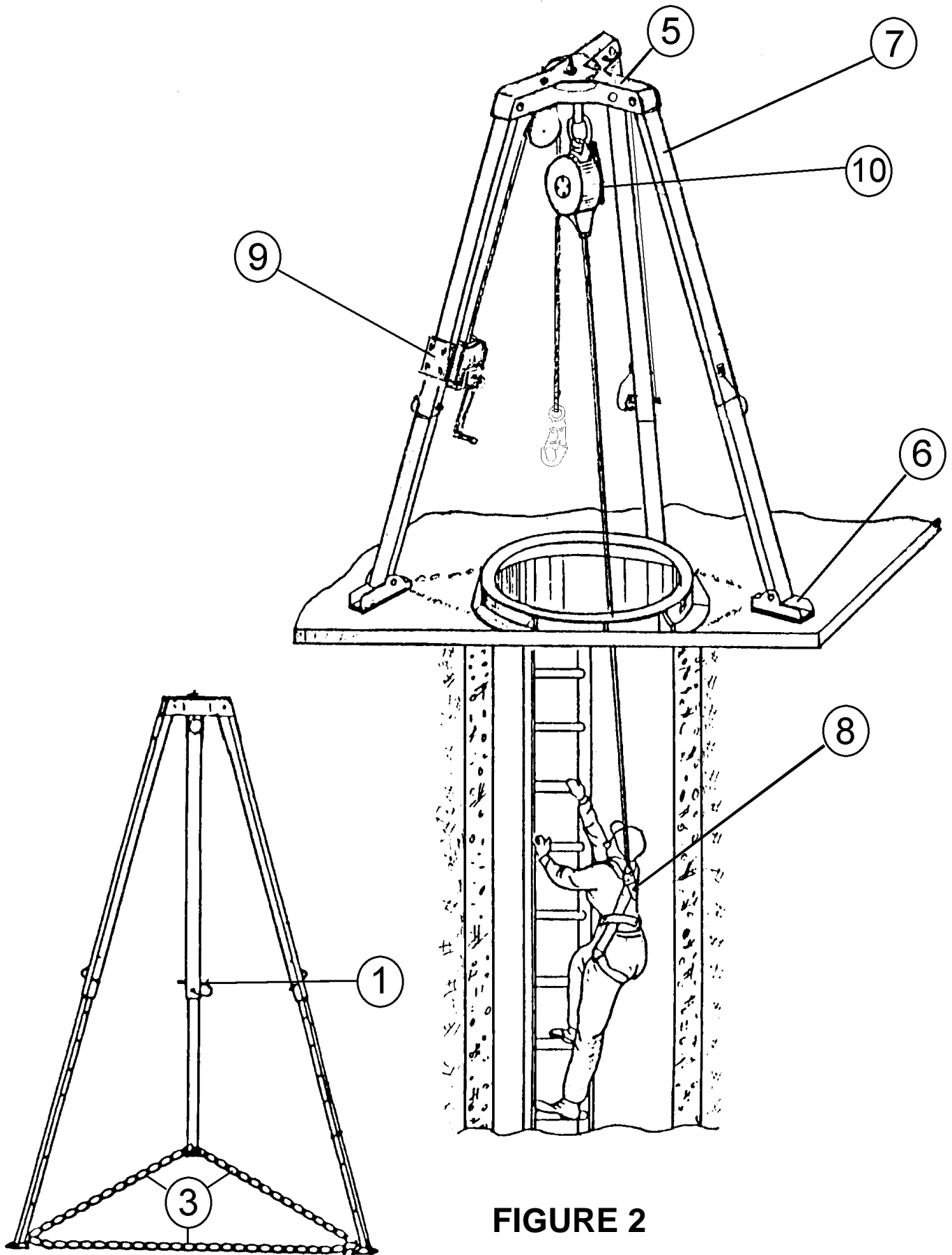

**FIGURE 2**

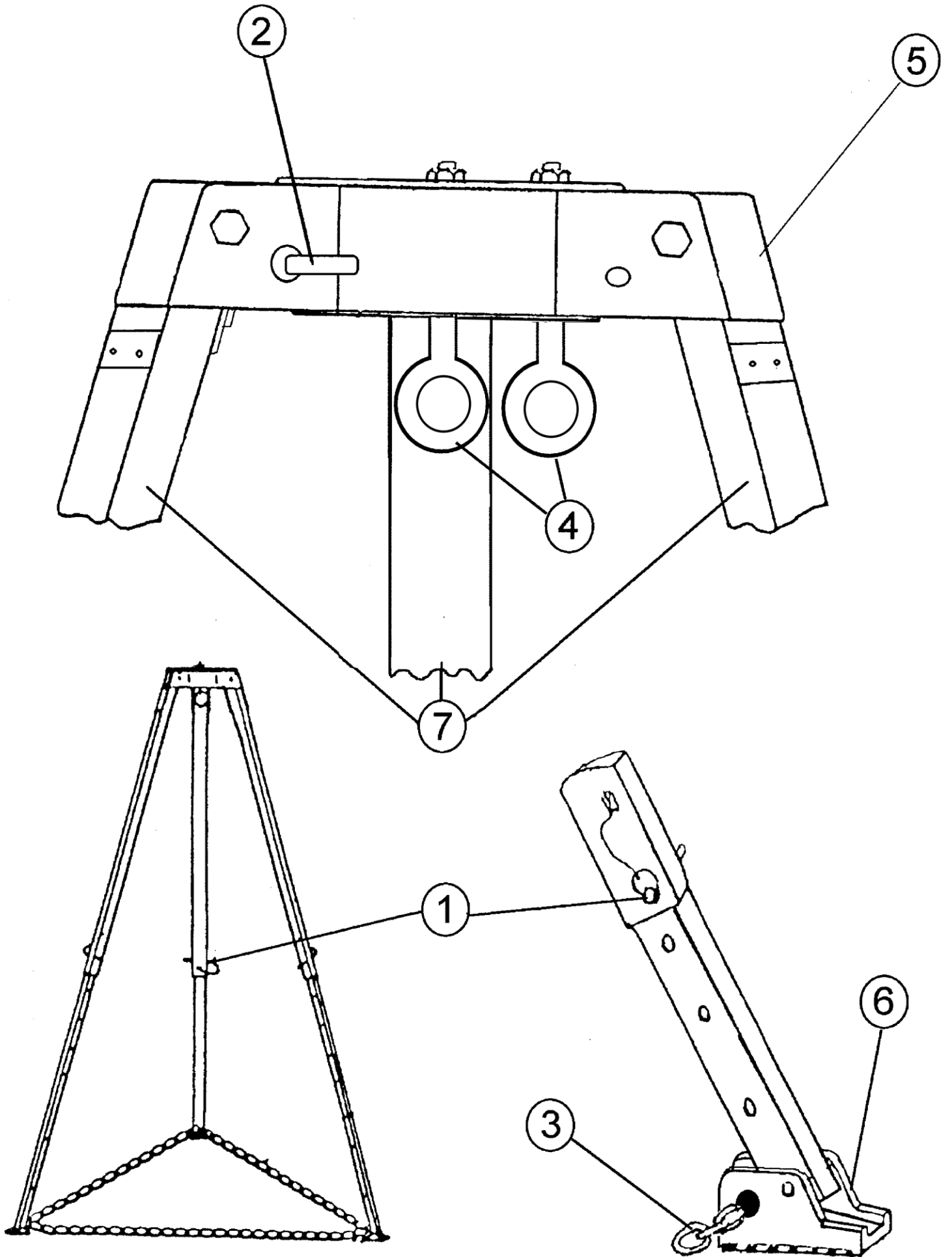

**FIGURE 3**

