

FRONTLINE

FALL PROTECTION



STEEL ANCHOR

INSTRUCTION MANUAL



THE INSTRUCTIONS APPLIES TO THE FOLLOWING MODELS:
R001



BKLF 05

FRONTLINE
FALL PROTECTION

SELF RETRACTABLE LANYARD INSTRUCTIONS

Do not skip this instruction manual. Read the instruction manual carefully before using the equipment. If failed in doing so it may cause serious injury or Death.

www.frontlinefall.com

This manual must be read and understood in its entirety and used as part of fall protection training program as required by OSHA or any state regularity agency. These instructions are intended to meet the manufacturer instructions as required by ANSI Z 359.1-2007 and OSHA . The user must fully understand the proper equipment use and limitations.

The Instruction applies to the following MODELS: RO01

Ref. No.	Product Name	Minimum Breaking System	Material of Construction	Complying Norm
RO01	Hinged Steel Roof Anchor (Reusable)	5000 lbs / 23 kN	Galvanized Steel with Stamped D-Ring	ANSI Z 359.1-2007

1. GENERAL REQUIREMENTS, WARNINGS AND LIMITATIONS: The Equipment is designed for use as a part of a personal fall protection system. Components must not be used for any other operation other than that which it has been designed and approved. Fall Arrest system are designed to comply with OSHA. Fall Restraint System must be designed by a Qualified Person, and must be installed and used under the supervision of a competent person.

All authorized persons/users must refer the regulations governing occupational safety, as well as applicable ANSI or CSA standards. Please refer to product labeling for information on specific OSHA regulations, and ANSI and CSA standards met by product.

Consult a doctor if there is any reason to doubt a user's ability to withstand and safely absorb fall arrest forces. Age, fitness, health conditions can seriously affect the worker a fall occur. Pregnant Women and minors should not use this equipment.

Proper precautions should always be taken to remove any obstructions, debris, material, or other recognized hazards from the work area that could cause injuries or interfere with the operation of the system. All equipment must be inspected before each use according to the manufacturer's instructions. All equipment should be inspected by a qualified person on a regular basis.

To minimize the potential for accidental disengagement, a competent person must ensure system compatibility.

Equipment must not be altered in any way. Repairs must be performed only by the Manufacturer, or persons or entities authorized in writing by the manufacturer.

Any product exhibiting deformities, unusual wear, or deterioration must be immediately discarded. Any equipment subject to a fall must be removed from service. The authorized person/user shall have a rescue plan and the means at hand to implement it when using this equipment.

Never use fall protection equipment for purposes other than those for which it was designed. Fall protection equipment should never be used for towing or hoisting.

All synthetic material must be protected from slag, hot sparks, open flames, or other heat sources. The use of heat resistant materials is recommended in these applications.

Never use natural materials (manila, cotton, etc.) as part of a fall protection system.

Do not expose this equipment to chemicals which may have a harmful effect on the materials used to construct it. Be especially aware of caustic environment, or those that contain high levels of organic acids or bases. If you are uncertain about the safe operation of this equipment in any environment, contact Frontline for further instructions.

Do not use the equipment near sharp edges, abrasive surfaces and looping around small diameter structural members.

Do not use the equipment around moving machinery or electrical hazards.

Frontline Steel Anchors should be used only with the combinations of components, sub-systems or both which may affect or interfere with the safe function of one another. Be certain that connecting devices are compatible and that other elements of the PFAS are safe to use and compatible before use.

2. SYSTEM LIMITATIONS & REQUIREMENTS: Consider the following limitations/requirements prior to installing or using this equipment:

CAPACITY: Frontline Steel Anchors are designed for use by ONE person with a combined weight (clothing, tools, etc.) of no more than 310 lbs. (140 kg) Make sure all of the components in your system are rated to a capacity appropriate to your application. All Frontline Steel Anchors are rated 5000lbs.

FREE FALL: Personal fall arrest systems used with this equipment must be rigged to limit the free fall to 6 feet (1.8 M) per ANSI Z359.1. Restraint systems must be rigged so that no vertical free fall is possible. Work positioning systems must be rigged so that free fall is limited to 2 feet (.6 m) or less. Personnel riding systems must be rigged so that no vertical free fall is possible. Climbing systems must be rigged so that free fall is limited to 18 inch. (.46 cm) or less. Rescue systems must be rigged so that no vertical free fall is possible. See subsystem manufacturer's instructions for more information. Below figure illustrates fall clearance requirements. There must be sufficient clearance below the user to allow the system to arrest a fall before the user strikes the ground or other obstruction. Clearance required is dependent on the following factors:

- ⊕ Elevation of Anchorage
- ⊕ Connecting Subsystem Length
- ⊕ Deceleration Distance
- ⊕ Free Fall Distance
- ⊕ Worker Height

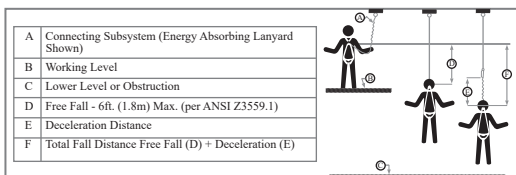

Movement of Harness Attachment Element

SWING FALLS: Swing falls occur when the anchorage point is not directly above the point where a fall occurs. The force of striking an object in a swing fall may cause serious injury or death. Minimize swing falls by working as close to the anchorage point as possible. Do not permit a swing fall if injury could occur. Swing falls will significantly increase the clearance required when a self-retracting lifeline or other variable length connecting subsystem is used.



ENVIRONMENTAL HAZARDS: Use of this equipment in areas with environmental hazards may require additional precautions to prevent injury to the user or damage to the equipment. Hazards may include, but are not limited to; heat, chemicals, corrosive environments, high voltage power lines, gases, moving machinery, and sharp edges.

COMPATIBILITY OF COMPONENTS: Unless otherwise noted, Frontline equipment is designed for use with Frontline approved components and subsystems only. Substitutions or replacements made with non-approved components or subsystems may jeopardize compatibility of equipment and may affect safety and reliability of the complete system.

COMPATIBILITY OF CONNECTORS: Connectors are considered to be compatible with connecting elements when they have been designed to work together in such a way that their sizes and shapes do not cause their gate mechanisms to inadvertently open regardless of how they become oriented. If the connecting element that a snap hook or Carabiner attaches to is undersized or irregular in shape, a situation could occur where the connecting element applies a force to the gate of the snap hook or Carabiner. This force may cause the gate (of either a self-locking or a non-locking snap hook) to open, allowing the snap hook or Carabiner to disengage from the connecting point. Connectors must be compatible in size, shape, and strength. Self-locking snap hooks and Carabiners are required by ANSI Z359.1 and OSHA.

Making Connections: Always use snap hooks and Carabiners which needs double manual action to open with this equipment. Only use connectors that are suitable to each application. Ensure all connections are compatible in size, shape and strength. Do not use equipment that is not compatible. Ensure all connectors are fully closed and locked. The connection should not be made-

- A. To a D-ring to which another connector is attached.
- B. In a manner that would result in a load on the gate.
- C. In a false engagement, where features that protrude from the snap hook or Carabiner catch on the anchor and without visual confirmation seems to be fully engaged to the anchor point.
- D. To each other.
- E. Directly to webbing or rope lanyard or tie-back (unless the manufacturer's instructions for both the lanyard and connector specifically allow such a connection).
- F. To any object which is shaped or dimensioned such that the snap hook or Carabiner will not close and lock, or that roll-out could occur.

NOTE: Other than 3,600 lb. (16 kN) gated hooks, large throat opening snap hooks should not be connected to standard size D-rings or similar objects which will result in a load on the gate if the hook or D-ring twists or rotates. Large throat snap hooks are designed for use on fixed structural elements such as rebar or cross members that are not shaped in a way that can capture the gate of the hook.

RESTRICTIONS REGARDING MAKING CONNECTIONS:

- Do not make connections where the hook locking mechanism can come into contact with a structural member or other equipment and potentially release the hook.
- Do not connect a snap hook into a loop or thimble of a wire rope or attach in any way to a slack wire rope.
- The snap hook must be free to align with the applied load as intended (regardless of the size or shape of the mating connector)
- A Carabiner may be used to connect to a single or pair of soft loops on a body support such as a body belt or full body harness, provided the Carabiner can fully close and lock. This type of connection is not allowed for snap hooks.
- A Carabiner may be connected to a loop or ring connector that is already occupied by an automatic closing connector.

If the connecting element that a snap hook (shown) or Carabiner attaches to is undersized or irregular in shape, a situation could occur where the connecting element applies a force to the gate of the snap hook or Carabiner. This force may cause the gate (of either a self-locking or a non-locking snap hook) to open, allowing the snap hook or Carabiner to disengage from the connecting point.

Figure 4 - Unintentional Disengagement (roll-out)

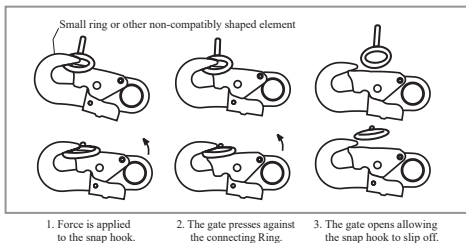
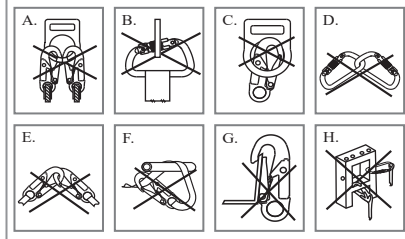

Figure 5 - Inappropriate Connections



CONNECTING SUB-SYSTEMS: Personal fall arrest systems used with this equipment must meet applicable state, OSHA and ANSI requirements. A full body harness must be worn when this equipment is used as a component of a personal fall arrest system. As required by OSHA, the personal fall arrest system must be capable of arresting the user's fall with a maximum arresting force of 1,800 lbs. (8 kN), and limit the free fall to 6 ft. (1.8 m) or less. If the maximum free fall distance must be exceeded, the employer must document, based on test data, that the maximum arresting force will not be exceeded, and the personal fall arrest system will function properly. Free fall greater than 6 ft. (1.8 m), and up to a maximum of 12 ft. (3.7 m) is possible, Frontline recommends using a personal fall arrest system incorporating a Frontline Energy Absorbing Lanyard. Frontline has performed testing using the Frontline Energy Absorbing Lanyard in free falls up to 12 ft. (3.7 m) to ensure the maximum arresting force does not exceed 1,800 lbs. (8.0 kN), and the system functions properly.

RESCUE PLAN: Rescue operation must be performed by the trained and competent personal. The rescue operation must be performed under the supervision of the rescue expert team or personal. It is advised that while working on site work in pairs. Before going for the work the user must have the rescue plan according to the work.

If Equipment Is Subjected To A Fall:

Remove the equipment from service immediately if it has been subjected to the forces of a fall arrest. Contact your distributor or Frontline about policies regarding replacement of Frontline components involved in a fall.

SPECIFIC INSTRUCTIONS: Frontline Anchors are designed to provide complete attachment system to user in the event of a fall. These attachment systems must be connected to the proper body support and connecting facility. These Anchors are meant to hold the victim of fall till the rescue operation is performed, so this is important that the whole system must have the all the essential components before going for the use. The whole fall arrest system must be used by the trained/competent person. It is advisable to make a checklist of the essential components according to one's use before going for work.

USE OF FALL ARREST SYSTEM: The fall arrest system **MUST ONLY** be connected to the back attaching element on the harness provided for the purpose ("D" ring or webbing attachment extension) or to the chest anchorage points ("webbing link" or "D" link). The chest anchorage points must imperatively be used together. The D-rings on the belt and the ventral anchorage point must only be used for the attachment of a work positioning or retaining system and never with a fall arrest system.

During use, check regularly the adjustment and/or attachment points.

INSPECTION: Before each use, proceed with thorough visual examination to ensure that the PPE is intact (the same applies for the equipment used with the harness (connectors, lanyard...) and take all necessary steps concerning the implementation of rescue in total safety. In the event of your product being contaminated, consult the manufacturer or authorized agent. If you have any doubts regarding the safe state of the product or if the product has been used to arrest a fall, for your personal safety, it is essential to withdraw the PPE from service and send it back to the manufacturer or a qualified repair Center for checking or destruction.

Following the inspection, the center will provide written authorization or refusal for the use of the PPE. Never attempt to modify or repair PPE.

Before each use of this equipment inspect it according to the following guidelines: A formal inspection of fall protection products/components must be performed at least every six months by a competent person other than the user. The frequency of formal inspections should be based on conditions of use or exposure. Record the inspection results in the inspection and maintenance log at the end of this manual. The component should be checked for Cut, Frayed, Heavily Soiled, welding burns etc. Metal parts like D-rings should be duly check for the crack, bent, deformities, corrosions etc.

INSTRUCTIONS FOR USAGE :

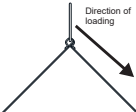
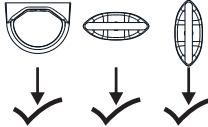
RO01	SA 10/SA 10A/ SA 10SS
<p>This Hinged Steel Roof Anchor is designed to be used as a temporarily installed anchorage connector on wood frame structures</p> <ul style="list-style-type: none"> ÿ Spread the anchor base legs apart to match the surface it will be mounted on, either a roof peak or flat surface. ÿ Position the anchor on the roof such that the nailing holes along with the center of the legs are over a framing member. ÿ Push down the anchor to butt the legs over the surface and use 20 Units of 16 D nails of 3 inches length. <p>The Anchor can be fixed so that the load impact is in the directions shown in the figure below :-</p> 	<p>This Single Point Anchor is to be used for anchorage in a fall arrest system. This anchor can be fixed to walls, ceilings, roof tops or steel structures present in the working environment.</p> <ul style="list-style-type: none"> ÿ For fixing to steel structures, drill one hole of dia 12.5mm in the steel structure (pass through) and bolt the anchor on to it by using one M 12 steel nut bolts. Ensure that the nut & bolt is tightened enough & not loose. ÿ For fixing to walls, ceiling and roof tops, fix only on ones made up of concrete and known to have compression strength of at least 3000 PSI. Use one M12 chemical fastener to be fixed in the drill made in to the concrete structure as per specification stated by the chemical fastener manufacture. <p>The Anchor can be fixed so that the load impact is in any of the directions shown in the figure below :-</p> 

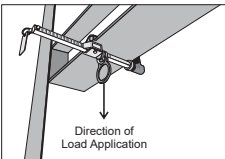
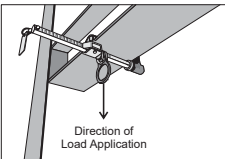
SA 08	SA 08M
<p>Beam anchor is intended to be installed on flanges of beam from 90 mm to 340 mm width.</p> <ul style="list-style-type: none"> ÿ Push the latch and adjust the movable jaw enough to allow the clamping jaws to fit over the flange of beam and release the latch to lock its position. ÿ Use the D-ring as connecting point. 	<p>Beam anchor is intended to be installed on flanges of beam from 75 mm to 150 mm width.</p> <ul style="list-style-type: none"> ÿ Push the latch and adjust the movable jaw enough to allow the clamping jaws to fit over the flange of beam and release the latch to lock its position. ÿ Use the D-ring as connecting point. 

SA 11
<p>Parapet anchor is intended to be installed on a parapet wall up to 14.1 inches (360mm) thick.</p> <p>Step 1: Unscrew the set screws so the points do not protrude into the anchor slot. Remove the detent pin and move the adjustable arm back far enough to allow the clamp to fit over the parapet wall.</p>

- Step 2:** Make sure the top surface within the anchor slot is fully seated on the parapet wall.
- Step 3:** Slide the adjustable arm toward the parapet wall and reinsert the locking pin through the appropriate position setting holes.
- Step 4:** Tighten each set screw until it makes contact with the parapet wall. Hands tighten the screws until snug. Excessive torque can damage the parapet wall or the parapet wall anchor.

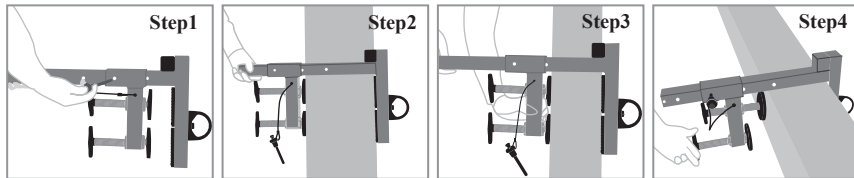

SA 13 / SA 13A

The Girder Steel Anchor may be attached to the structure by pulling on the spring loaded trigger component.

- When pulling on the spring loaded trigger, the blade rotates to a parallel position to the stem. The device is then inserted through a bolt hole in the range of 21 mm to 30 mm.
- Ensure that the spring loaded blade returns to its original perpendicular position after the blade has cleared the hole in the steel work do not use the bolt hole anchor in a horizontal fashion. The device is to be used overhead and in a vertical position.



SQUEEZE TO TWIST LOCK



RELEASE TO ACTIVATE LOCK

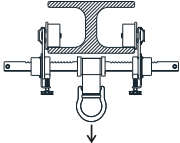
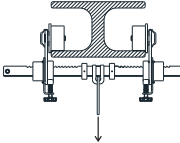
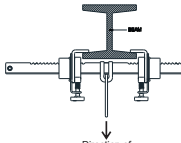

Tested in Direction

SA 15	SA 15 A / SA 15 B	SA 27
<p>Beam Anchor Trolley is intended to be installed on flanges of beam from 80 mm to 250 mm width.</p> <p>ÿ Push the latch and adjust the movable jaw enough to allow the clamping jaws to fit over the flange of beam and release the latch to lock its position.</p> <p>ÿ Use the D-ring as connecting point.</p>	<p>Beam Anchor Trolley is intended to be installed on flanges of beam from 80 mm to 250 mm width.</p> <p>ÿ Push the latch and adjust the movable jaw enough to allow the clamping jaws to fit over the flange of beam and release the latch to lock its position.</p> <p>ÿ Use the D-ring as connecting point.</p>	<p>Beam Anchor is intended to be installed on flanges of beam from 90 mm to 290 mm width.</p> <p>ÿ Push the latch and adjust the movable jaw enough to allow the clamping jaws to fit over the flange of beam and release the latch to lock its position.</p> <p>ÿ Use the D-ring as connecting point.</p>
 <p>Direction of Load Application</p>	 <p>Direction of Load Application</p>	 <p>Direction of Loading</p>

*SA 15 B Comes With Dielectric Roller having Dielectric Resistance of 30 kV.

*Dielectric Property : If the coating of the Dielectric part is found broken or damaged remove it immediately from use

ANCHORAGE STRENGTH : The Anchorage strength required depends on the application type. The following are the requirements of ANSI 359.1 for these application types.

ANCHORAGE & ANCHORAGE STRENGTH : Anchorage and anchorage strength requirements are dependent on the full body harness application (see Figure 3). In accordance with ANSI Z359.1, anchorages selected for fall Arrest Systems must meet the anchorage strength requirements defined in Table 2.		
Table 2 - Anchorage Strength Requirements		
Fall Arrest¹	Non-Certified Anchorage:	5,000lbs (22.2 kN)
	Certified Anchorage ²	2 Times the Maximum Arresting Force for Certified Anchorage
Restraint¹	Non-Certified Anchorage	1,000 (4,5 kN)
	Certified Anchorages ²	2 times the foreseeable force for certified anchorages.
Work Positioning¹	Non-Certified Anchorages	3,000 lbs (13.3 kN)
	Certified Anchorage ²	2 times the foreseeable force for certified anchorage.
Rescue¹	Non-Certified Anchorage	3,000 lbs (13.3 kN)
	Certified Anchorage ²	5 times the foreseeable force for certified anchorage.
Climbing	The structure which a climbing system is attached must sustain the loads required by that particular system. See the instructions for the climbing system for requirements.	
<p>1 Multiple Systems: When more than one of the defined system is attached to an anchorage, the strength defined for Non-Certified or certified anchorage shall be multiplied by the number of systems attached to the anchorage.</p> <p>2 Certified Anchorage: An anchorage for fall arrest, positioning, restraint, or rescue systems that a qualified person certifies to be capable of supporting the potential fall force that meet the criteria for a certified anchorage prescribed in this standard.</p>		

- A. **Fall Arrest:** Anchorages selected for fall arrest systems shall have a strength capable of sustaining static loads applied in the directions permitted by the system of at least: 1. 5,000 lbs. (22.2 kN) for non-certified anchorages, or 2. Two times the maximum arresting force for certified anchorages. When more than one fall arrest system is attached to an anchorage, the strengths set forth in (1) and (2) above shall be multiplied by the number of systems attached to the anchorage.

As Per OSHA : Anchorages used for attachment of personal fall arrest systems shall be independent of any anchorage being used to support or suspend platforms and capable of supporting at least 5,000 lbs.(23 kN) per user attached, or be designed, installed and used as part of a complete PFAS which maintains a safety factor of at least two, and is under the supervision of a qualified person.

- B. **Work Positioning:** The structure to which the work positioning system is attached must sustain static loads applied in the directions permitted by the work positioning system of at least 3,000 lbs., or twice the potential impact load, whichever is greater. See OSHA. When more than one work positioning system is attached to an anchorage, the strengths stated above must be multiplied by the number of work positioning systems attached to the anchorage.
- C. **Restraint:** Anchorages selected for restraint and travel restraint systems shall have a strength capable of sustaining static loads applied in the directions permitted by the system of at least: 1. 1,000 lbs. (4.5 kN) for non-certified anchorages, or 2. Two times the foreseeable force for certified anchorages. When more than one restraint and travel restraint system is attached to an anchorage, the strengths set forth in (1) and (2) above shall be multiplied by the number of systems attached to the anchorage.
- D. **Rescue:** Anchorages selected for restraint and travel restraint systems shall have a strength capable of sustaining static loads applied in the directions permitted by the system of at least: 1. 3,000 lbs. (13.3 kN) for non-certified anchorages, or 2. Five times the foreseeable force for certified anchorages. When more than one restraint and travel restraint system is attached to an anchorage, the strengths set forth in (1) and (2) above shall be multiplied by the number of systems attached to the anchorage.

FALL CLEARANCE : If there is a risk of fall or if the only anchorage is below the attachment points on the harness, it is essential to use a lanyard provided with an energy absorber. Before using a shock-absorbing lanyard, check that there is sufficient fall clearance below the user to prevent any collision with the structure or the ground.

⇒ **PERIODIC EXAMINATION** : Keep these instructions with the product and fill in the identification sheet, entering the information taken from the markings.

The periodic examination is essential to test the resistance and condition of the equipment and to guarantee the safety of the user.

A qualified person must examine this equipment at least twice each year in strict compliance with the instructions of the manufacturer and the previous check must be recorded on the attached sheet.

The frequency of inspection should be increased in accordance with the regulations, if the equipment is in heavy usage or if the equipment is used in harsh environments. Check also that the markings are legible.

MATERIAL & CONSTRUCTION

Materials

- ⇒ Galvanized Steel.

System Requirements:

- ⇒ **Compatibility of Components:** Frontline Fall Protection equipment is designed to be used with Frontline approved components. Please contact Frontline if you have a question regarding compatibility. Making substitutions without approval from Frontline Fall Protection may lead to injuries and or death by compromising the safety and reliability of the complete system. A Qualified person can make a determination on compatibility of equipment from different manufacturers.
- ⇒ **Compatibility of Connectors:** Connectors (D-rings, hooks, Carabiners) must be capable of supporting at least 5,000 lbs. (22kN). Do not use equipment that is not compatible. Non-compatible connectors may unintentionally disengage. Self-locking snap hooks and Carabiners are required by CSA, ANSI and OSHA. Connectors must be compatible in size, shape, and strength.
- ⇒ **Making Connections:** Only use self-locking snap hooks and Carabiners with any Frontline Fall Protection equipment. Do not use equipment that is not compatible.

OTHERS:

Maintenance & Cleaning : Repairs to equipment can be made only by a Frontline representative or person or entity authorized by Frontline. Contact Frontline for maintenance and repair. Cleaning after use is important for maintaining the safety and life of the equipment. Cleanse the equipment of all dirt, corrosives, and contaminants. If the equipment cannot simply be wiped clean use a mild soap and water. Rinse, wipe, and hang to dry in shade.

Storage : Store the anchorage connector component in a cool, dry and clean place out of direct sunlight. Avoid areas where heat, moisture, light, oil, and chemicals or their vapors or other degrading elements may be present. Equipment which is damaged or in need of maintenance should not be stored in the same area as usable equipment. Heavily soiled, wet, or otherwise contaminated equipment should be properly maintained (e.g. dried and cleaned) prior to storage.

Prior to using equipment which has been stored for long periods of time, a Formal Inspection should be performed by a competent person. For harnesses with Dielectric buckles, pass-thru buckles or Quick Connect Buckles, store the harness with the buckles connected.

Training : It is the responsibility of the users to assure that they read, understand, and follow all instructions and are trained in the care and use of this device. Training should be repeated periodically and any time there is a change of components within the system. Training must be conducted without exposing the trainee to a fall hazard

- ⇒ As Per OSHA : Anchorages used for attachment of personal fall arrest systems shall be independent of any anchorage being used to support or suspend platforms and capable of supporting at least 5,000 lbs. (22.2kN) per user attached, or be designed, installed and used as part of a complete PFAS which maintains a safety factor of at least two, and is under the supervision of a qualified person.

PRODUCT MARKINGS :



Product Code : RO01
 Product Description : Steel Anchor
 Batch No. : MM/YY
 Minimum Breaking Strength : 5000lbs



Read the user instructions carefully before each use.

For Single User only
 weighing 310 lbs
 Maximum



Material : Galvanized Steel, Meets OSHA and ANSI Z 359.1-2007 Requirement for use as an Anchorage Connector.

Warning : manufacturer's instructions supplied with this product at time of shipment must be followed for proper use, maintenance and inspection. Use only with ANSI/OSHA approved personal fall arrest or restraint systems. Alteration or misuse of this product or failure to follow instructions may result in serious injury or death.

Avoid contact with any sharp edge/abrasive surface

Avoid using in environment where extreme heat, chemical and electrical hazards are evident, as it may directly affect the functionality.



Installation



INSPECTION LOG

SERIAL NO. XXXXXXXX

MO	J	F	M	A	M	J	J	A	S	O	N	D
20												
20												
20												
20												
20												

Inspection – Product must be inspected by user/authorized person before each use. A competent person must check & record at intervals of every 3 months.



DO NOT REMOVE THIS LABEL.

9.0. INSPECTION AND MAINTENANCE LOG

	J	F	M	A	M	J	J	A	S	O	N	D
YR												
YR												
YR												
YR												
YR												

Warning -

- a) Do not skip user instructions supplied with this product.
- b) Alternation or misuse of this product or failure to follow instructions may lead to serious injury or even death.

If equipment fails inspection IMMEDIATELY REMOVE FROM SERVICE.

SERIAL NUMBER:	
MODEL NUMBER:	
DATE PURCHASED:	DATE OF FIRST USE:

INSPECTION DATE	INSPECTIONS ITEMS NOTED	CORRECTIVE ACTION	MAINTENANCE PERFORMED
Approved by:			
Approved by:			
Approved by:			
Approved by:			
Approved by:			
Approved by:			
Approved by:			
Approved by:			
Approved by:			
Approved by:			
Approved by:			
Approved by:			
Approved by:			
Approved by:			
Approved by:			
Approved by:			
Approved by:			
Approved by:			
Approved by:			
Approved by:			
Approved by:			
Approved by:			
Approved by:			
Approved by:			
Approved by:			

DISCOVER MORE ...

