

# SPEC SHEET

## Safety Guardrail Boot Base with Hardware Included



GPB200

### Features

The most compact and lightest Guardrail Boot Base in the market

Ideal for perimeter protection on the different leading edges, holes/openings or stairways

Includes integrated toe board slots and washers

### Design Specifications

Weight 1.5 lbs

Material High strength ABS Plastic

Finish Safety green painting

Dimensions 7.5" L x 7.5" W x 5<sup>1</sup>/<sub>5</sub>" H

Application Concrete and Wooden Substrates

### Relevant Standards

OSHA 1926  
1910

**PATENT PENDING**

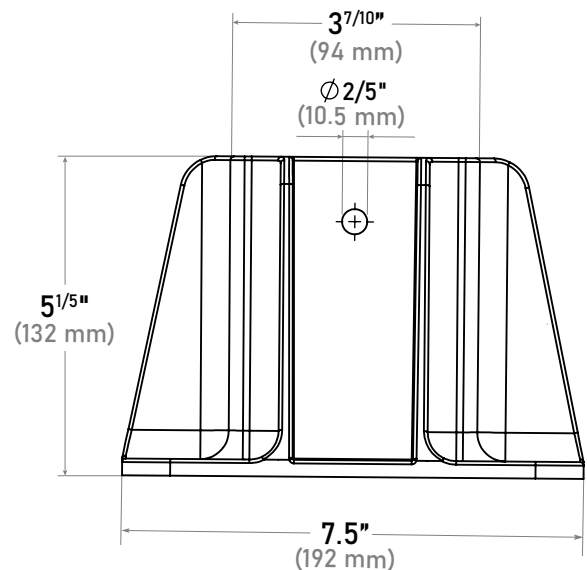

**FRONTLINE**  
FALL PROTECTION

www.frontlinefall.com info@frontlinefall.com

2111 NW 84th Ave, Miami FL, 33122