



SUPER ANCHOR SAFETY®

No. 1207 SSCA Standing Seam Anchor Instruction/Specification Manual 2020

ENGLISH
VERSION

!WARNING TO USER!

You are required to read and use the Instruction/Specification manual supplied at the time this device was shipped. Improper use and installation can result in serious injury or death. Follow inspection requirements before each use.

Materials

SSCA Base Plate: 3/8" 5052 Aluminum

SSC Seam Clamps: 1/4" Q235 Steel
HDG coating

RCT™ Clamps: Aluminum w/sst set screws

Attachment Bolts: Use only **SAS** supplied attachment bolt types and dimensions specified in this manual.

DO NOT drill additional holes in the SSCA base plate.

DO NOT use bolts supplied by others.

Specified Use

Permanent or temporary standing seam fall protection anchor for 1 person.

Use for fall arrest, fall restraint or **SAS** engineered HLL system.

DO NOT use for window washing, hoisting or scaffold tie-off.

User wt: 310lb/person with tools and equipment

Max. Free Fall: 6ft

Max. Slope: 8/12

PPE: Required to use current ANSI, CSA or OSHA compliant PPE.

Use of a personal energy absorber (E/A) or SRL equipped with an internal or external E/A.

Fall Restraint Definition OSHA 1926.751

"A means of fall protection that prevents the user from falling any distance."

Table 1 SSCA Base Plate Specifications:

Part No.	Part Name	Plate Size	Panel Seams O.C.
1207-12x18	SSCA 12x18	Small Base Plate	12" up to 18"
1207-14x22	SSCA 14x22	Medium Base Plate	14" up to 22"
1207-18-24	SSCA 18x24	Large Base Plate	18" up to 24"

PPE Anchor Attachment

Use only **SAS** supplied grade 8 or 18-8 sst attachment bolts as specified in Table 2 and secure with lock nuts. Bolt threads must penetrate the lock nut 1/8" as shown at Fig.3. Install anchors at the specified base plate bolt-hole locations as shown at Fig.2.

Prior use: consult the specific PPE anchor Instruction/Specification manual before use with SSCA standing seam anchor.

Standing Seam Compatibility

Min. metal panel thickness is 24ga. The user is responsible to determine if the SSCA specified seam clamps are compatible with the standing seam to which it is being attached to. Follow the instructions in this manual and consult panel mfg. appendixes "A" and "B".

Structural Support

Metal panel attachment to the supporting structure and the supporting structure itself must be capable of supporting 5,000lb or 2x the intended fall protection load per OSHA 1910.140(13).

Compliance

SAS in this manual = Super Anchor Safety
ANSI Z359.1-07/OSHA 1926.502

Fig.1

SSCA Standing Seam Anchor

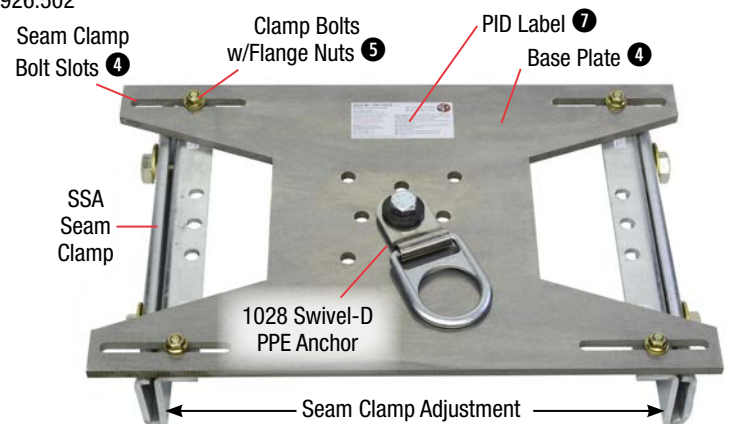

Table 2 SSCA Compatible PPE Anchors

Part No.	Type	Installation Bolt	See Fig.
1028	Swivel D-Ring	1ea 5/8"x 2-1/2"	Fig.3
1090-GBS	Loop Top	1ea 5/8"x2.0"	Fig.6
1215	SRL-UH	1ea 5/8"x 2-1/2"	Figs.8-9
1037	D-Plate	4ea 1/2x1-1/2"	Fig.7
1029	D-ShakL	2ea 1/2x1-1/2"	Figs.4-5

Note: All bolts require lock nuts

Fig.2

Anchor Attachment Bolt Holes
SSCA Base Plate Top View

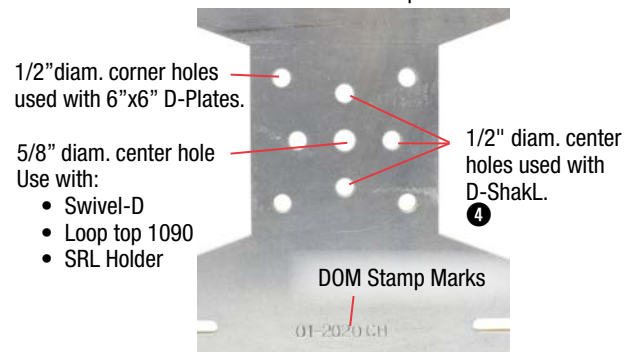

Note: Bolt hole locations are designed for use with SAS compatible anchors.

Fig.5

D-ShakL Front View

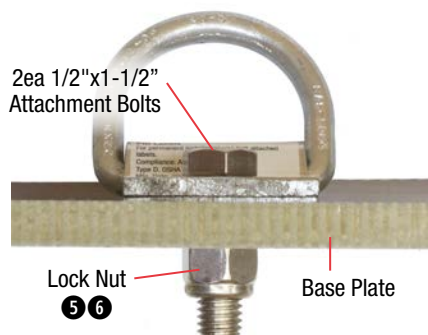

Fig.4

D-ShakL Top View

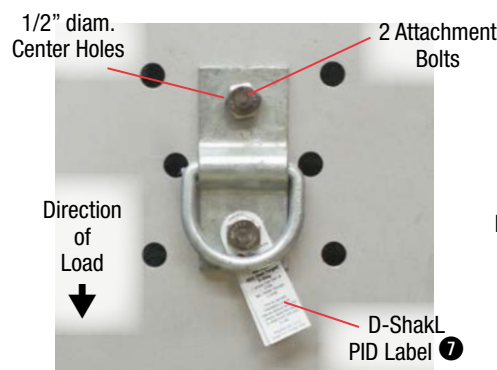

Fig.3

Swivel-D No. 1028

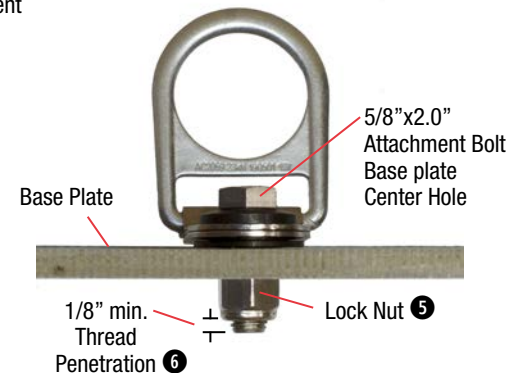

Fig.6

Loop Top 1090-GBS

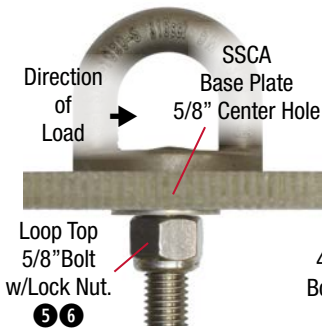

Fig.7

D-Plate No. 1037
3/8"x6"x6"

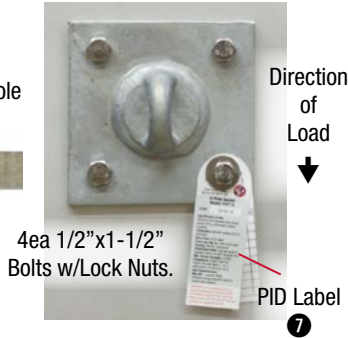

Fig.8

SRL-UH No. 1215
SRL Holder

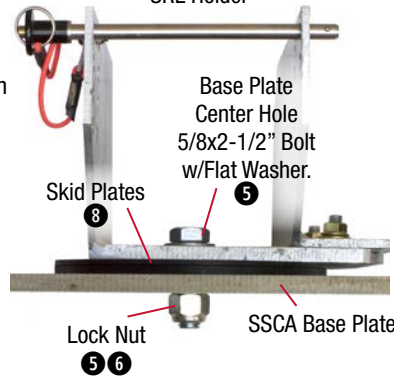

Fig.9

SRL Holder



Pre-Installation and Panel Seam Compatibility

- 1) Use base plate sized for panel seam width. See Table 1.
- 2) Confirm SSC (Fig.10) or RCT (Fig.16) seam clamps are compatible with the metal panel seam. Consult RCT Addendum "A" Panel Specifications.
- 3) A qualified* person must determine seam clamp compatibility prior to installation. It is recommended to test with a sample panel.

*Qualified Person: see OSHA Definition.

Fig.10

SSC No. 1208 Seam Clamp

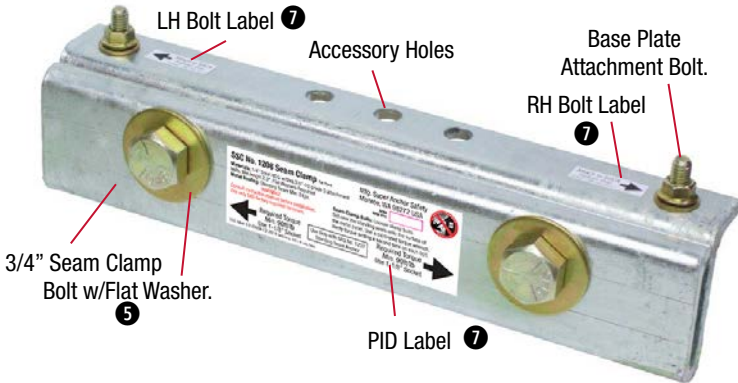

SSC Seam Clamp Installation

- With 3/4" clamp bolts facing out, attach seam clamps to SSCA Base Plate through bolt slots as shown at Fig.1 and 13, leaving flange nuts loose enough to allow centering of the base plate.
- Set seam clamps over metal panel seams and center the base plate as shown at Fig.11. Tighten 3/4" clamp bolts sufficiently to prevent movement leaving flange nuts loose. See 10.1 and Fig.13.
- Using a calibrated torque wrench w/1-1/8" socket, tighten 3/4" clamp bolts to 50 ft.-lb as shown at Fig.12.
- Fully tighten flange nuts with a 9/16" wrench or socket. See Fig.14.

Fig.10.1

SSC Seam Clamp Fasteners

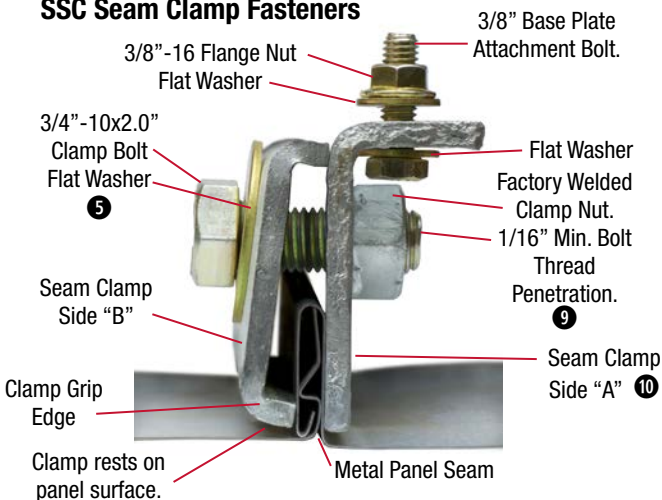

Fig.11

SSCA Installation/Alignment

← = | Center Base Plate onto Seam Clamps | = →

Direction of Slope ↓



Fig.12

Clamp Seam Bolt Torque

Tighten bolts evenly with a min. of 2 passes to ensure torque.

Fig.10.2

No. 1208 SSC Metal Panel Compatibility



Snap Lock high profile or Mechanical Seam Only.

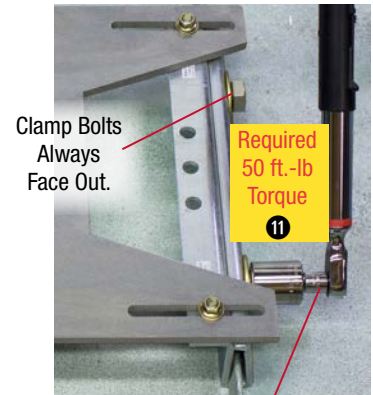

Calibrated Torque Wrench w/1-1/8" socket

Fig.13

SSCA Base Plate Bolts

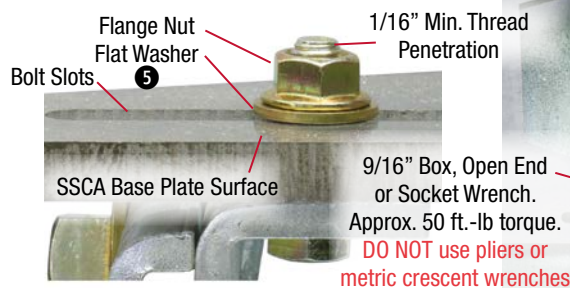

Fig.14

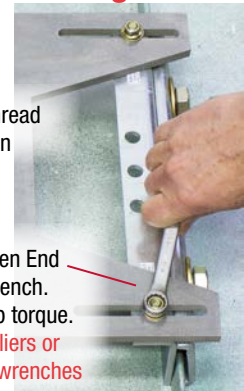
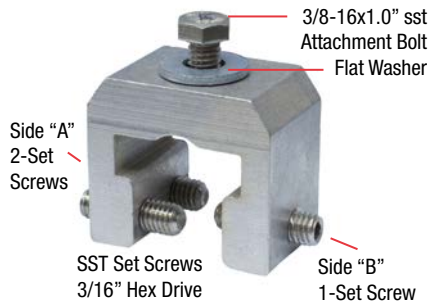

Fig.15
RCT* Clamp No. 8511



*RCT Clamps: Consult www.snoblox-snojax.com for updated panel compatibility specifications and additional installation instructions.

Panel Seam Compatibility

- 1) Confirm the RCT clamp is compatible before installation. Consult Appendix "B" and locate the panel mfg. Pre-install onto the panel seam as shown at Fig.16.
Note: For seam heights greater than 1-1/4" the clamp center will rest on the seam top.
- 2) Determine the SSCA base plate size required to fit the panel width. Attach PPE anchor to the base plate as shown on pages 1 and 2. DO NOT attach RCT clamps to the base plate until installation step 4 has been completed.

Installation Procedure

- 1) Determine installation location of SSCA and set clamps onto the seams with the single set screw side "B" against the seam's inside. Align clamps horizontally and about 12" apart as shown at Fig.17.
- 2) Center clamps over standing seam as shown at Fig.16 and hand tighten side "A" and side "B" set screws alternately. Perform same on all 4 clamps.
- 3) Shown at Fig.18, tighten clamp #1 set screws with a 3/16" hex drive coupled to a universal. Use a cordless drill set at #15 torque. The panel seam must remain centered in the RCT clamp.
- 4) Loosen side "A" set screws slightly on clamps #2, #3, and #4 to allow vertical movement required to align the base plate bolt slots over the clamp.
- 5) Attach base plate to clamp #1 with 3/8"x1.0" bolt w/flat washer and leave loose to allow for base plate movement during final clamp torqueing. See Fig.19.
- 6) Adjust clamps #2, #3 and #4 position as necessary to align with base plate bolt slots and attach same as 5) above. Leave bolts slightly loose.
- 7) Using a cordless drill set at the highest torque #15, tighten all "A" side set screws. Ensure clamps remain centered over the panel seams as shown at Fig.18. Centering clamps may require a few adjustments to the "A" and "B" side set screws.
- 8) Using a calibrated torque wrench set at 90 in.-lb. or 8 ft.-lb. tighten each clamp separately, starting with side "B" set screw first as shown at Fig.19, then tighten both side "A" screws alternately as shown at Fig.20 to maintain clamp centering as close as possible. After final torqueing, make a second pass to ensure torque specification has been met.
- 9) Securely tighten 3/8" base plate bolts with a 9/16" wrench or socket drive. Installation is complete.

Base Plate Centered over Clamps.
Attachment Bolts w/Flat Washers.

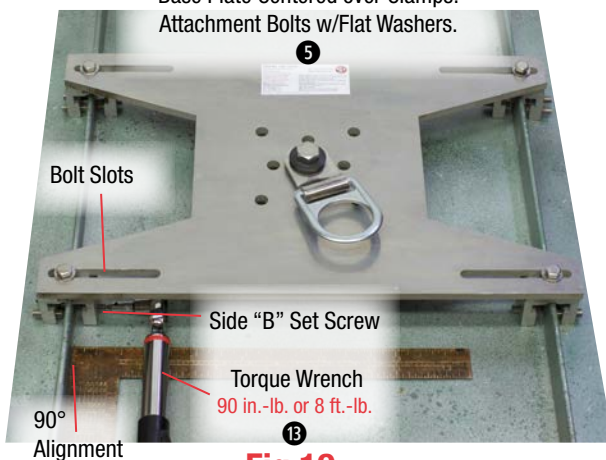

Fig.19
SSCA Base Plate Attachment

Fig.16
Pre-Installation Compatibility

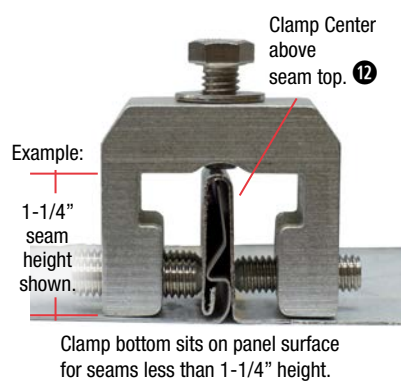

Fig.17
Clamp Alignment

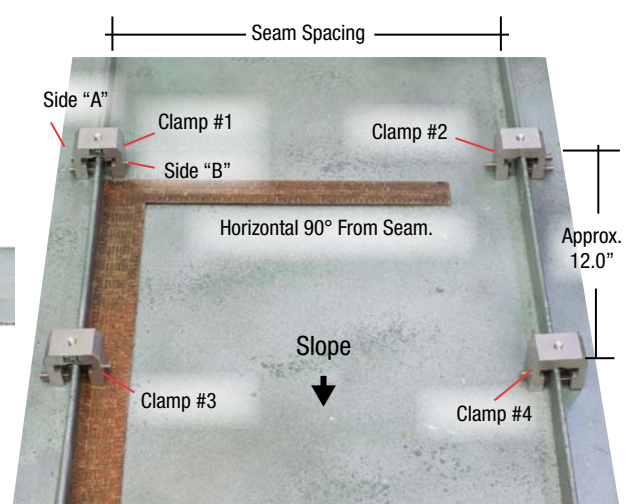

Fig.18
Clamp Attachment

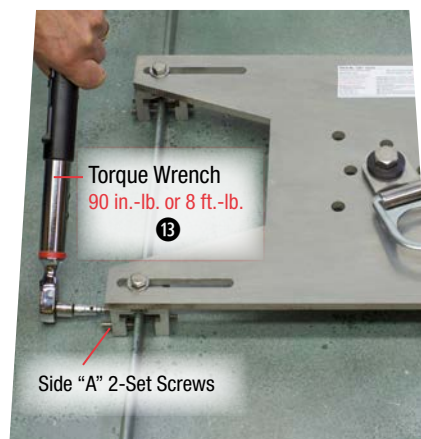
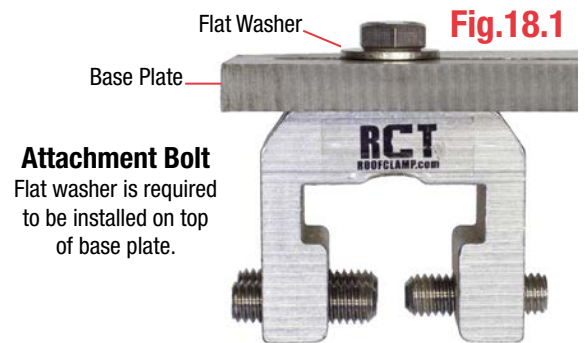
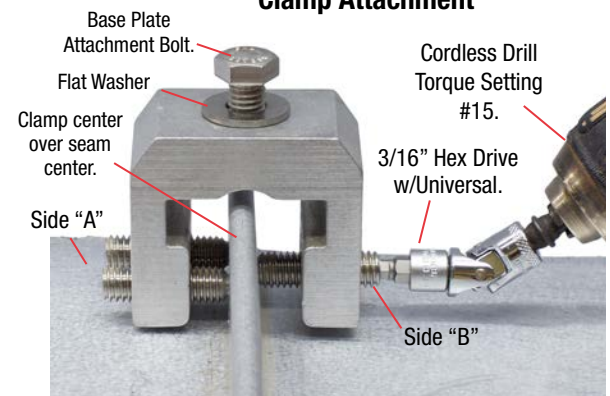

Fig.20
Clamp Side "A" Torque



Fig.21
Clamp Bolt Attachment

Sample Length of Fall Plan (LOFP)

Components shown in this sample plan are mfg. by **SAS**. DO NOT apply to PPE mfg. by others. LOFP must be calculated to prevent contact with the ground or lower level in the event of a fall. Users are required to engineer their own Job Specific Plan (JSP). **WARNING! This sample plan does not apply to leading edge fall hazards for SRL's**

Fall Arrest Sample LOF Plan

Calculation is based on the max. deployment length of all components. Free fall "A" = B + C 72" (1.8m)

Service Zones

PPE lifeline, lanyard or SRL attached to the PPE anchor must not exceed the following service zone angles:
Fall Arrest: 30° off center. Max free fall 6ft. **Fall Restraint:** 360° no free fall exposure.

Fig.22

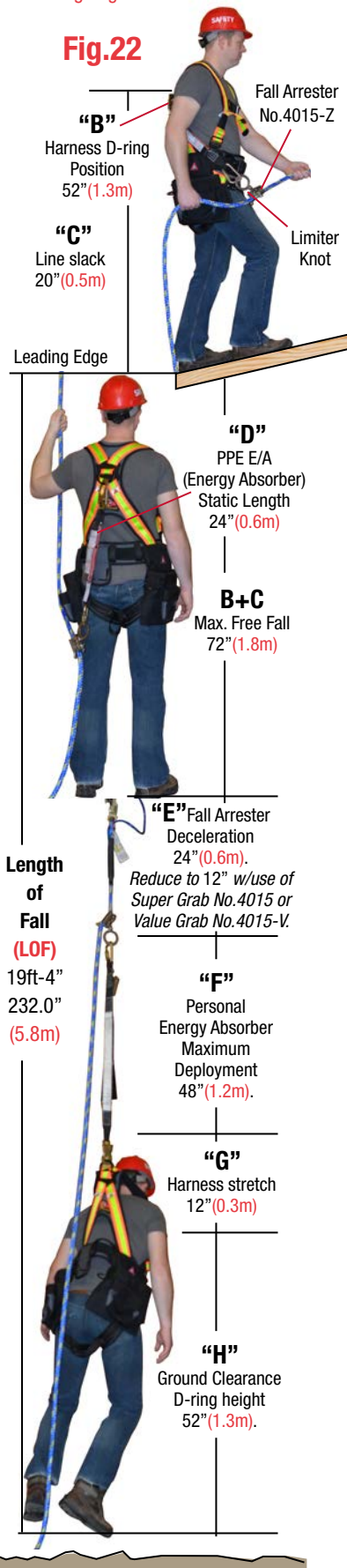

LOF Factors

"B" D-Ring Ht.	52" (1.3m)
"C" Line Slack	20" (0.5m)
"D" PPE-E/A static length	24" (0.5m)
"E" Fall Arrestor	24" (0.6m)
"F" Absorber	48" (1.2m)
"G" Harness	12" (0.3m)
"H" Ground	52" (1.3m)

Total (LOF) 232"/19ft.4" (5.8m)

WARNING WHEN A FALL OCCURS!

Prompt Rescue:

A plan for immediate rescue is required to avoid serious injury or death from suspension trauma. As a safety precaution, equip workers' full body harnesses with **SAS** No. 6060 Trauma Strap and provide training.

Ground Clearance:

A failure to calculate the LOF+ ground clearance and correctly rig PPE can result in striking the ground or a lower level and may result in serious injury or death.

Annual and Daily Inspections:

Inspect all components prior to each use and inspect annually by a competent person. A written plan for service, maintenance, removal from service and user training should be maintained for SSCA and PPE components. The following inspection points may be used as a guideline to inspect for normal wear, tear and abuse.

Remove equipment from service if any non-repairable conditions are present:

- 1 Subjected to a free fall or other force.
- 2 Obvious damage to any component.
- 3 Fails inspections or has not been inspected annually.

ACTION REQUIRED:

=Remove =Repair

SSCA Base Plate/PPE Anchors

- 4 Base plate bent, deformed, cracked, or bolt slots are damaged. Inspect PPE anchor bolt holes for damage.
- 5 Confirm flange or lock nuts are tight. DO NOT use if replaced with other types. Order replacement flange nuts. Missing flat washers. Install washers.
- 6 PPE attachment bolt thread min. is not visible. Replace attachment bolt with correct length.
- 7 PID Label missing or not legible. Request replacement label.

SRL-UH No. 1215

- 8 Skid Plates required. Consult SRL-UH manual for inspections. If plates missing, install.

No. 1028 Seam Clamps

- 9 3/4" bolt nut welds are cracked. Flat washers missing. Install washers.
- 10 Clamp legs are damaged or deformed.

Ridge Line

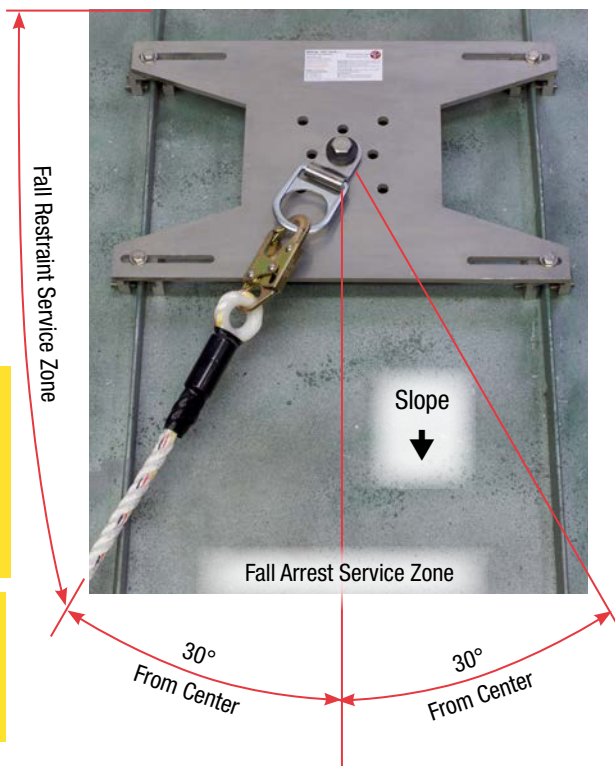
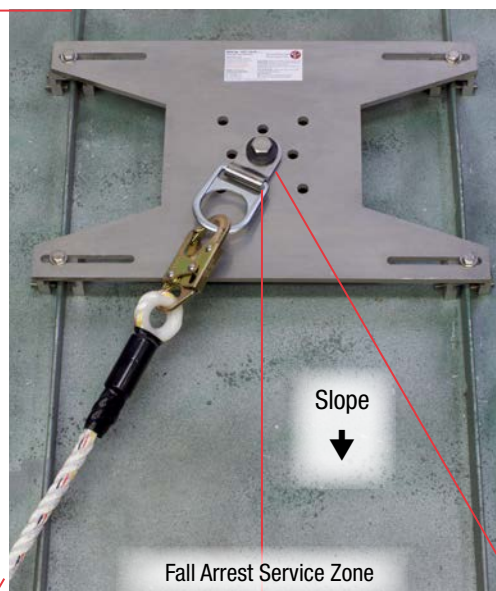

Fig.23



Advisory! All equipment removed from service should be tagged and disposed of in a way that prevents further use.

- 11 Confirm bolt torque is accurate. Re-torque if necessary.
- 12 Confirm panel seam compatibility has been met.

No. 8511 RCT Seam Clamps

- 13 Confirm Set screw alignment and torque. Re-torque if necessary.

SSCA PID Label Min. Seam Width
Model No. Max. Seam Width

SSCA No. 1207-12x18 Pat-Pend
Standing Seam Commercial Anchor

Specification of Use: Personal Fall Protection anchor for temporary or permanent attachment to standing seam metal roofing. **WARNING! Consult instruction manual included with this device prior to installation and use.**

Material: 5052 Aluminum
Standing Seam Requirement: Min. Metal gauge: 24
Min. Seam Width: 11.5"
Max. Seam Width: 18.0"
SSCA Label 1.0 ©SCN 12-2019 (MIT) Temp. SSCA 1.0 Mfg. China

Mfg. Super Anchor Safety
Monroe, WA 98272 USA

Seam Clamps: Requires 2ea SAS No. 1208 or 4ea No. 1209.
Anchor Types: Requires to use an SAS supplied PPE anchor as specified in the SSCA instruction manual.
Service Load: Apply as specified for the anchor type being used. Consult manual
User Specifications: 1 person with a max. user wt. 310lb. including tools and equipment
Max. Free Fall: 2ft.
PPE: Use of a personal energy absorber required.
SRL: Requires an energy absorbing component.

SSCA No. 1207-14x22 Pat-Pend
Standing Seam Commercial Anchor

3 model sizes.
See Table 1.

SSCA No. 1207-18x24 Pat-Pend
Standing Seam Commercial Anchor