

## CS TWIN ASSEMBLY INSTRUCTIONS

1. Swing out the 2 cross arms as shown below. Secure each cross arm to the side rail with one nut and bolt, and tighten. Then, slide the end caps over the foot ends of both side rails.

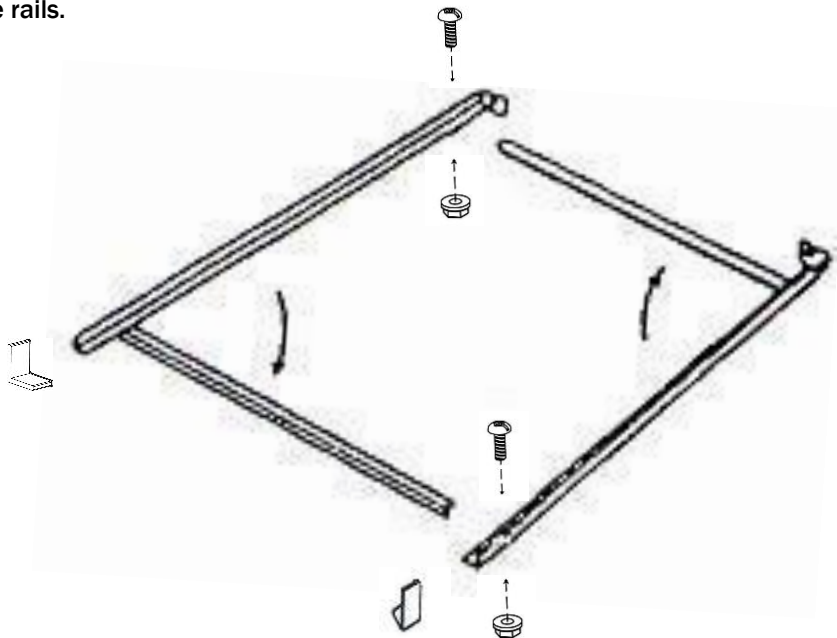

2. Secure the 4 strap braces to the side rails with the remaining nuts and bolts, and screw the threaded glides all the way into the legs until the pre-installed nuts are tight against the strap braces.

