

# ADA3456 Assembly Instructions:

Designed to be used for Twin, Full, Queen, King, or California King Beds.

## Frame parts:

- (1) Left Side Rail Fig. 1
- (1) Right Side Rail
- (1) Center Rail Fig. 4 & 6

- (2) King Extenders - Fig. 5
  - Used on King and Cal-King only

## Assembly Parts included :

- (4) End Caps
- (4) Keyhole Plug Locks
- (6) Nuts
- (6) Bolts
- (4) 5/16 Hex Nuts
- (6) Threaded Glides

- 1** Swing out cross arms from side rails. Position the slotted headboard brackets toward the head end of the bed.

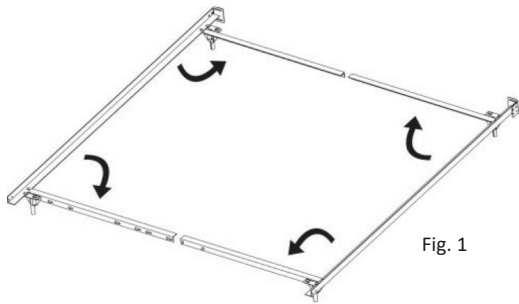

- 2** Slide the end caps onto both ends of the side rails.

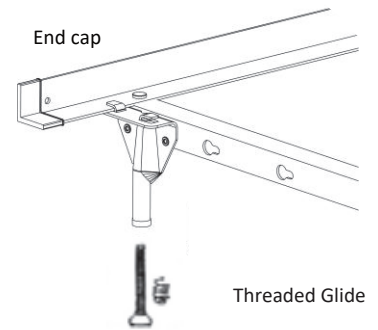

## **4** Twin, Full, or Queen size assembly:

Locate the key hole slots that correspond to the bed size you need. (Fig. 3) Insert rivets into key hole slots, then slide to lock into place. Insert plug locks into keyhole openings to secure cross arms into position. (Fig. 3) A total of 2 plug locks are used for Full & Queen sizes. None are required for Twin size.

Repeat at the other end of the bed.

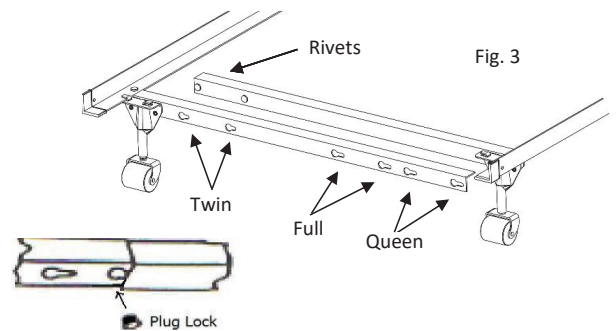

## **Full and Queen size center rail assembly:**

To attach the center rail to a Queen size bed: Line up the hole at the end of the center rail under the hole in the middle of the side rails.

The center rail on the Queen size frame should be parallel to the cross rails.

The center rail for the Full size frame should be diagonal (Fig. 4). Secure the center rail with a screw and thumb nut.

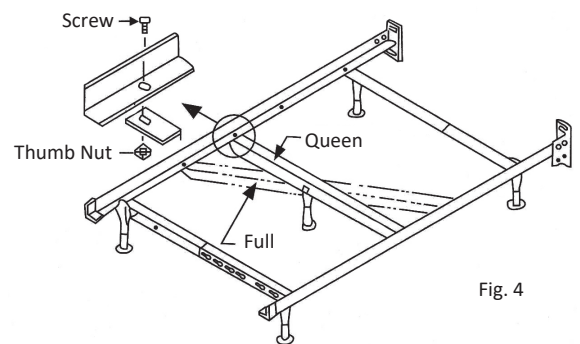

## **5** King or California King size cross arm assembly:

Insert the rivets on the king extender into the queen keyhole setting shown in Fig. 3 & Fig. 5. Slide to lock into place.

Locate the key hole slots on the king extender that correspond to the bed size you need. (Fig. 5) Insert the rivets on the other cross arm into the keyholes you selected then slide to lock into place

Insert plug locks into keyhole openings to secure the overlap & lock the king extender into place. A total of 4 plug locks are used for King & California King sizes. Repeat all steps at the other end of the bed.

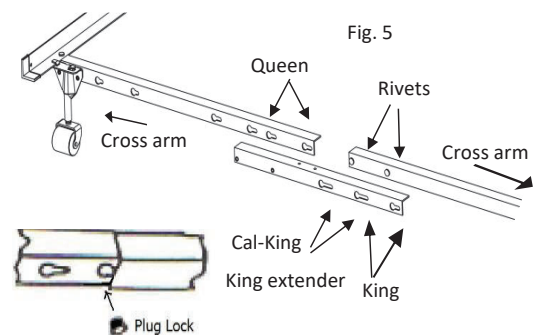

**6 Continued: King or California King size center rail assembly:**

For King and California King sizes, attach the center rail head-to-foot, parallel to the side rails. Position the center rail in the middle of the king extenders. Secure the center rail with a screw and thumb nut as shown below.

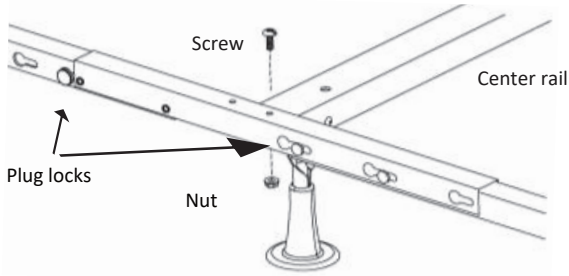
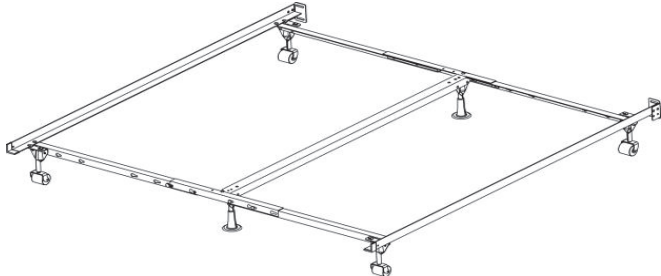

Fig. 6



**The center rail is required for Full, Queen, King, and California King sizes. Twin size does not require a center rail.**

**7 Attach Strap Braces:**

Place 5/16" hex nut on threaded glide stem and screw it on about 1 inch from the end. Insert the threaded glide stem through one end of the strap brace and screw into leg. Hand tighten until you reach the hex nut. Line up the opposite hole of the strap brace with the hole in the angle iron as shown. Insert bolt from the top and secure with a nut on the bottom. Tighten all nuts and bolts

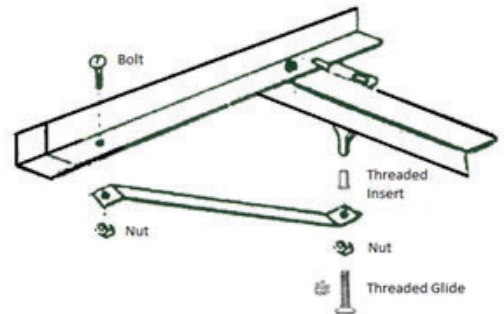

Shown: ADA3456

