

# Astro Packaging L4 Handgun Applicator

## Now with Pump and Motor Switch Capability!

The L4 Handgun is a lightweight, manually operated applicator for hot melt adhesives and other thermoplastic materials. A flexible heated hose supplies hot melt adhesive from the melt unit to the handgun. L4 Handguns come either “switched” or “unswitched” and are available in high temperature models that are rated for high temperatures and more rigorous applications.

The “switched” L4 handgun has pump/motor control within the handgun trigger and activates the pump and motor only when the trigger is pulled. The ability to control pump and motor activity maximizes the performance and extends the lifetime of the pump while also providing a much safer environment for operators.

### ○ Precision

Clean cut-off and material placement with trigger switch activation and Astro nozzles. RTD sensing for precise temperature control.

### ○ Durability

Built with impact resistant high-heat plastic for the most dependable and durable manual hot melt applicator.

### ○ Flexibility

Available in 120V or 240V electrical configurations with either RTD or Thermostat heating sensors.

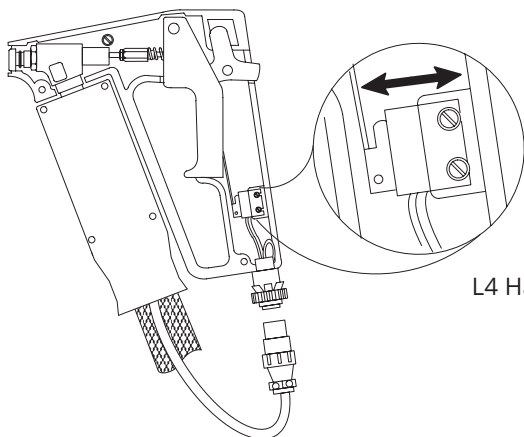

L4 Handgun Trigger Switch

# L4 Handgun Details

## Specifications:

### Handgun Weight

1.75 lbs. (0.8 kg)

### Handgun Swivel

Unswitched: 360° Continuous

Switched: Restricted to 360°

## Temperature Control:

### Thermostat Models:

#### Handgun:

Preset fixed thermostat in handgun body.  
Select 25°F increments from 200-450°F

#### Hose:

Capillary bulb in hose with adjustable  
thermostat in melt unit.

### Solid State Models:

#### Handgun:

RTD sensor located in handgun body. Full  
range solid state temperature controller  
located in melt unit.

#### Hose:

RTD sensor located in hose. Full range  
solid state temperature controller located  
in melt unit.

## Performance:

### Operating Temperature

100-450°F

### Operating Pressure

Maximum 500 PSI (10,34 kPa)

### Warm-Up Time

30-45 Minutes

### Viscosity

Maximum 25,000 cPs

## Electrical:

### Voltage

120V, 240V

50/60 Hz, Single Phase

### Power Requirements:

#### Handgun:

80W Cartridge Heater

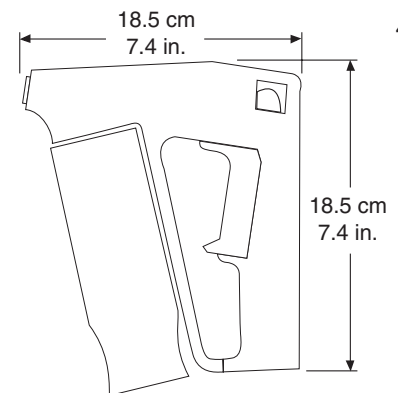
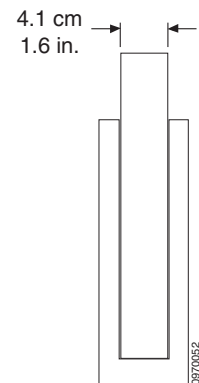

L4 Handgun with down apply adapter kit.  
Part # 79302-01

