

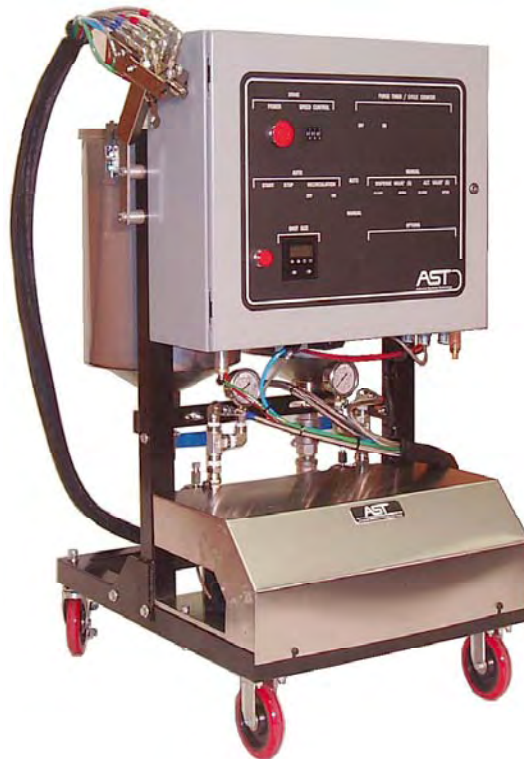

GMP 075, 100 & 200

MOLDING, FILLING & DISPENSING USING
NON-FILLED URETHANES, EPOXIES & POLYUREAS



FEATURES AND BENEFITS

- Bench Mounted or Portable
- Uses AST GMP metering pump
- Continuous flow up to 1-4 gpm
- Fluid pressures up to 1,000 psi
- Fixed Ratios of 1:1 to 6:1
- Variable flow rate
- Viscosities up to 10,000 cps
- 9 gallon stainless steel tanks
- Automatic dispense valve
- Electric/pneumatic powered
- ¾ HP DC drive motor
- Handles non-abrasive materials

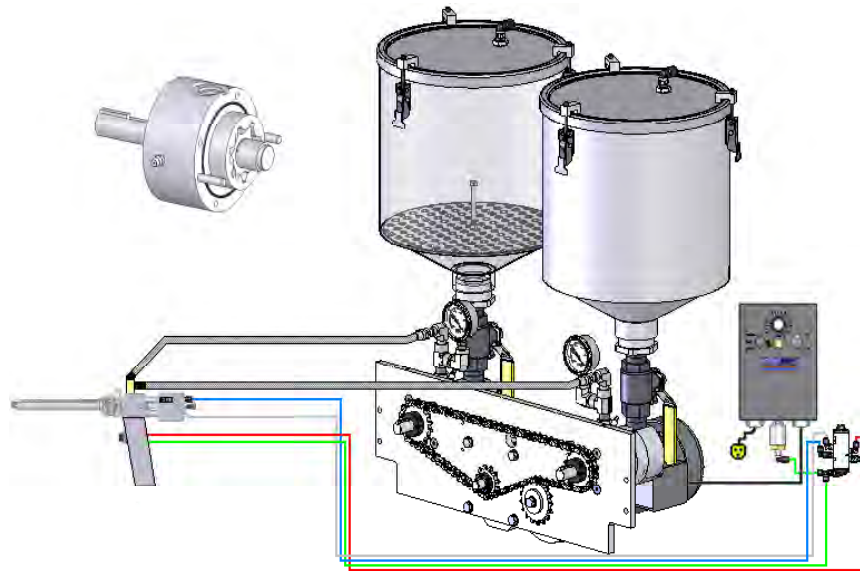

PRODUCT SPECIFICATIONS

	GMP-075	GMP-100	GMP-200
MODEL	Bench Mounted or Portable (Optional)		
PUMPS	Positive Displacement AST Gear Metering Pumps		
DRIVE SYSTEM	¾ HP Electric	1.0 HP Electric	2.0 HP Electric
SHOT RATE	1cc – 2 oz. per second	2cc – 4 oz. per second	4cc – 8.5 oz. per second
SHOT ADJUSTMENT	0-100% by adjusting motor speed		
CONTINUOUS OUTPUT	Up to 1.0 gpm	Up to 2.0 gpm	Up to 4.0 gpm
ACCURACY	To within 2% shot to shot		
PRESET RATIO RANGE	1:1 – 6:1		
VISCOSITY	1 cps – 30,000 cps		
POWER FACTOR	5:1, 10:1, 20:1		
SUPPLY CONTAINER	Gravity Feed or 2.5 Gal. Poly Tanks Standard (Stainless Steel Tanks Optional)		
DISPENSING MANIFOLD	Fixed Mounted or Hand Held Manual Standard (Automatic Optional)		
CONTROLS	Electric Variable Speed 110/220v, Pneumatic 80 psi		
HOSE	6' S/S Braided Teflon Standard (Any length optional)		

OPTIONS:

- Foot Control
- Material Temperature Control
- Material Agitation
- Pressurized Material Day Tanks
- Material Low Level Sensors
- Automatic Material Refill System
- Material Recirculation
- Automatic Purge
- Parts Counter
- Variable Ratio
- Electric Drive
- Air Over Hydraulic
- Material Transfer Pumps
- Additional Shot Sizes
- Vacuum De-Air
- PC Controllers
- XYZ Motion
- Automated Dispense Lines
- Cure Ovens
- Part Pallets