

# ASSEMBLY INSTRUCTIONS

## LIST OF WOODEN PARTS

NO.	DESCRIPTION	Q'TY
A1	RIGHT SIDE FRAME	1 PC
A2	LEFT SIDE FRAME	1 PC
B	SEAT	1 PC
C	BACK SUPPORT	1 PC

### QUESTION ?

Identify all parts and hardware. If any pieces are missing call our toll free number at 1-888-287-4275 from 9:00 am to 5.00 pm CST (Monday to Friday) for replacwment parts. For faster service, have the style number handy when calling.

## LIST OF HARDWARE PARTS :

D   
1 1/2" BOLT ..... 6 PCS + 1

E   
WOODEN CAP ..... 6 PCS + 1

- NOTE : 1. PLEASE READ THE INSTRUCTION SHEET CAREFULLY BEFORE YOU START ASSEMBLY.  
2. PLEASE DO NOT TIGHTEN THE BOLTS UNTIL ALL BOLTS ARE IN THE CORRECT POSITION AS SHOWN IN THE DIAGRAM.  
3. PHILLIP'S SCREWDRIVER IS NEEDED IN ASSEMBLING (NOT PROVIDED).

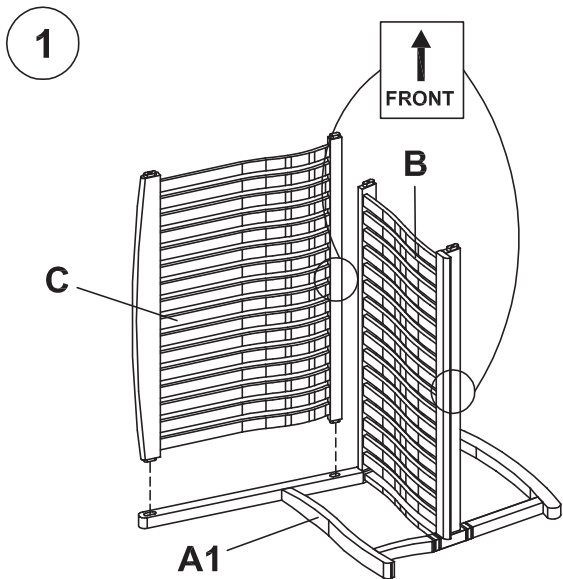

Attach back support (C) and seat (B) on to right side frame holes (A1). ( Apron with round edge must attached in front).

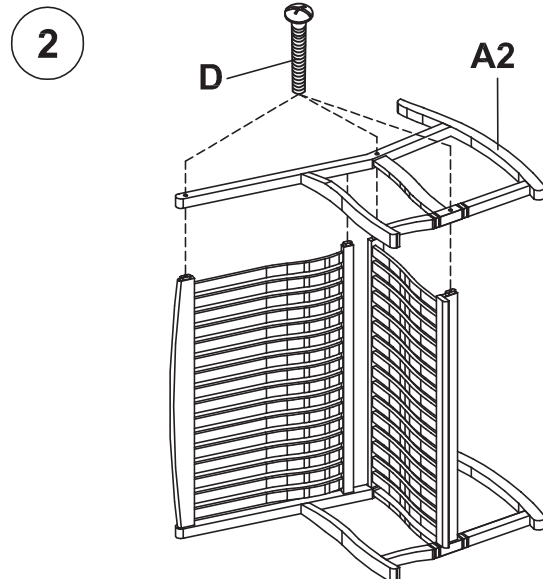

- Attach left side frame (A2) to the assembly from step 1, insert 1 1/2" bolts (D), as shown.  
\*\* Do not fully tighten all bolts yet.

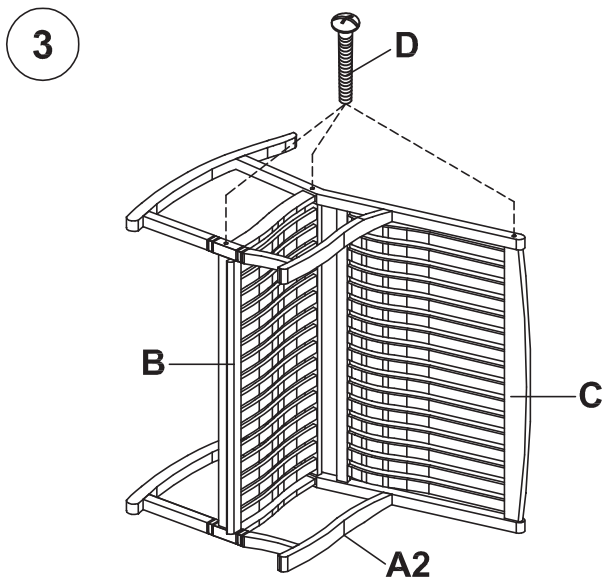

Invert the chair and repeat step 2 procedure to secure frame.

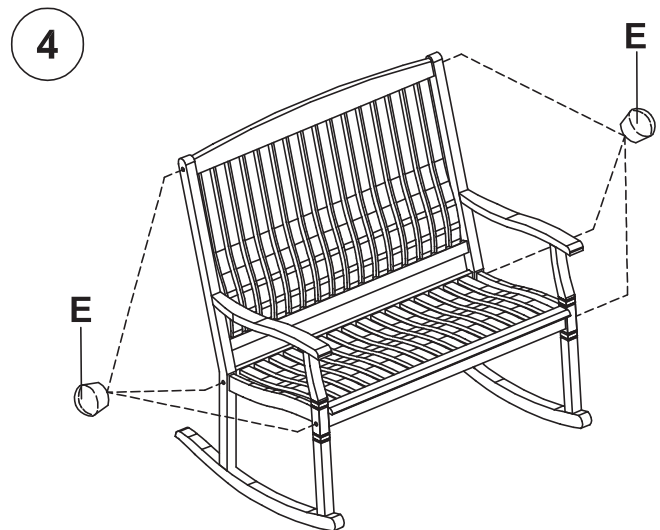

- Stand the chair upright.  
- Make sure all parts are correctly connected and tighten all bolts completely using screwdriver.  
- Tapping in the wooden caps (E) to cover bolts head using rubber mallet.